

P.C.B. HOLE DRILLINGS

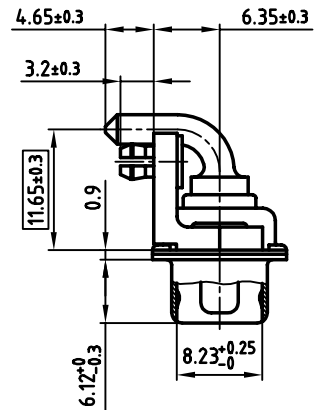

NOTES:

1. METAL SHELLS: STEEL; min. 320µ" TIN
2. INSULATORS: PBT GF UL 94 V-0, GREEN
3. HIGH POWER CONTACTS: COPPER ALLOY
4. PLATING: min. 30µ" HARD GOLD OVER min. 50µ" NICKEL
5. METAL BRACKET: STEEL; min. 320µ" TIN over 80µ" NICKEL
6. THREADED INSERT: COPPER ALLOY; min. 200µ" TIN over 80µ" NICKEL
7. PCB-SNAP: COPPER ALLOY; min. 200µ" TIN over 80µ" NICKEL
PCB-HOLE: $\phi 3.1 \pm 0.1$; PCB THICKNESS 1.6mm
8. MAXIMUM TORQUE VALUE FOR THREAD: 6" LBS
9. CONNECTOR IS PART MARKED: 302W2CPXX56N40X CONEC Y/W/W
10. = CRITICAL DIMENSION

APPROVAL # FREIGABE # DEBLOCAGE # AUTORIZACION # APPROVAL

CUSTOMER APPROVAL DATE:

NAME: TITLE:

COMPANY NAME:

APPROVAL # FREIGABE # DEBLOCAGE # AUTORIZACION # APPROVAL

THIS DRAWING MAY NOT BE COPIED OR REPRODUCED IN ANY WAY, AND MAY NOT BE PASSED ON TO A THIRD PARTY, WITHOUT WRITTEN PERMISSION. OWNERSHIP AND COPYRIGHT OF CONEC GmbH DO NOT ALTER CAD DRAWING BY HAND

rev.	description	date	name
1 x b	Ä 1726	07.02.2003	Parei

tolerance	scale:
	2:1
	material:
	SEE NOTES
	title:
	D-SUB COMBINATION MALE 90° ② 2W2CP with threaded insert, metal bracket and clip
	dwg no:
	AutoCAD 2000 DIN-A 13K1A717 3 sh:1/1
	part no:
	302W2CPXX56N40X

