

DESCRIPTION

The EV2615-Q-00A is an evaluation board for MP2615, a switching charger for 1- or 2- cell lithium-Ion or lithium-Polymer battery packed with built-in power MOSFETs. It's able to achieve up to 2A charge current which can be programmed via an accurate sense resistor over the whole input range.

MP2615 regulates the charge current and full battery voltage using two control loops to realize high accuracy constant current (CC) charge and constant voltage (CV) charge.

Thanks to the constant-off-time (COT) mode control, 99% duty cycle can be achieved when battery voltage is close to the input voltage to keep the charge current always at a relative high level.

Battery temperature and charging status are always monitored for each condition. Two status monitor output pins are provided to indicate the battery charging status and input power status. The MP2615 also features internal reverse blocking protection.

ELECTRICAL SPECIFICATION

Parameter	Symbol	Value	Units
Input Voltage	V_{IN}	4.75 to 18	V
Battery Voltage	V_{BATT}	0 to 8.4	V
Charge Current	I_{CHG}	2	A

FEATURES

- 4.75V to 18V Operating Input Voltage
- Up to 99% Duty Cycle Operation
- Up to 2A Programmable Charging Current
- $\pm 0.75\%$ Full Battery Voltage Accuracy
- 4.1V/Cell and 4.2V/Cell Selection for Full Battery Voltage
- Full Integrated Power Switches
- Internal Loop Compensation
- No External Reverse Blocking Diode Required
- Preconditioning for Fully Depleted Battery
- Charging Operation Indicator
- Programmable Safety Timer
- Thermal Shutdown Protection
- Cycle-by-Cycle Over Current Protection
- Battery Temperature Monitor and Protection

APPLICATIONS

- Smart Phones
- Portable Hand-Held Solutions
- Portable Media Players

All MPS parts are lead-free and adhere to the RoHS directive. For MPS green status, please visit MPS website under Products, Quality Assurance page.

"MPS" and "The Future of Analog IC Technology" are registered trademarks of Monolithic Power Systems, Inc.

EV2615-Q-00A EVALUATION BOARD



(L x W x H) 2.48" x 2.48" x 0.063"
(6.3cm x 6.3cm x 0.16cm)

Board Number	MPS IC Number
EV2615-Q-00A	MP2615GQ

EVALUATION BOARD SCHEMATIC

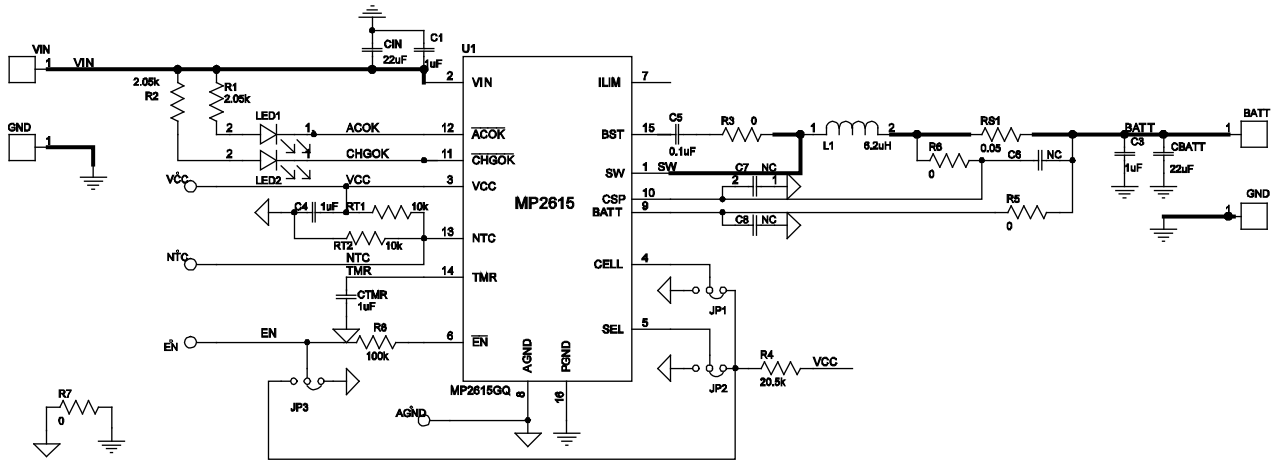

EV2615-Q-00A BILL OF MATERIALS

Qty	Ref	Value	Description	Package	Manufacturer	Manufacturer P/N
4	C1, C3, C4, CTMR	1 μ F	Ceramic Capacitor;25V;X7R;	0603	muRata	GRM188R71E105KA12D
3	C6, C7, C8	NC				
1	C5	0.1 μ F	Ceramic Capacitor;16V;X7R;0 603	0603	muRata	GRM188R71C104KA01D
2	RT1, RT2	10k	Film Resistor;1%	0603	Yageo	RC0603FR-0710KL
2	R1, R2	2.05k	Film Resistor;1%;	0603	Yageo	RC0603FR-072K05L
1	R4	20.5k	Film Resistor;1%;	0603	Yageo	RC0603FR-0720K5L
4	R3, R5, R6, R7	0	Film Resistor;5%;	0603	Yageo	RC0603JR-070RL
5	R8	100k	Film Resistor;1%;	0603	Yageo	RC0603FR-07100KL
1	LED2	BL- HUF35A -TRB	LED;RED;	0805	BRIGHT LED	BL-HUF35A-TRB
1	LED1	BL- HGB35A -TRB	LED;GREEN;	0805	BRIGHT LED	BL-HGB35A-TRB
2	CBATT, CIN	22 μ F	Ceramic Capacitor;25V;X5R	1206	muRata	GRM31CR61E226KE15
1	RS1	0.05	Film Resistor;1%;1/4W	1206	Yageo	RL1206FR-070R05L
1	L1	6.2 μ H	Inductor;6.2 μ H;24m; 4.3A	SMD	Würth	7440660062
1	U1		MPS Switching Charger	FCQFN1 6 (3mmx3 mm)	MPS	MP2615GQ
2	BATT, VIN		Connector			
3	JP1, JP2, JP3		Connector			

PRINTED CIRCUIT BOARD LAYOUT

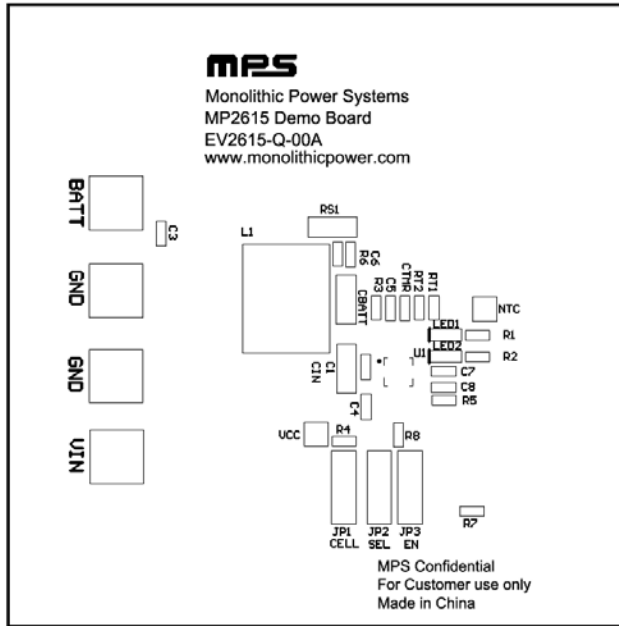

Figure 1— Top Silk Layer

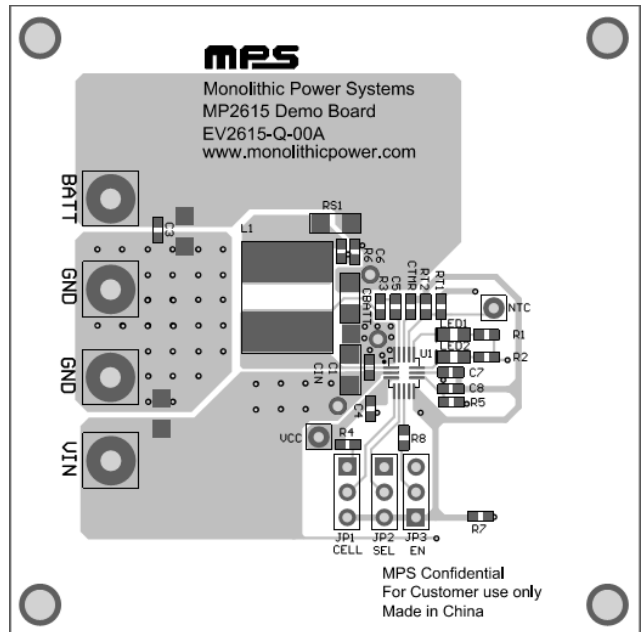
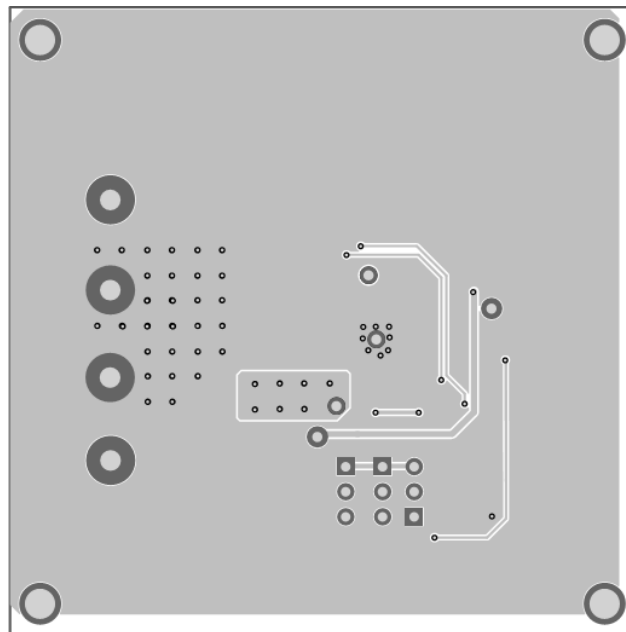

Figure 2—Top Layer



QUICK START GUIDE

This board is used for the evaluation of MP2615 applications, which is a switching charger for 1- or 2-cell lithium-Ion or lithium-Polymer battery packed with built-in power MOSFETs. The board layout accommodates most commonly used capacitors.

1. The EV2615-Q-00A evaluation board can select the number of battery cells. Setting CELL in different logic can set the cells in different spec. Table 1 shows how to set the cells spec through JP1 according to different application conditions.

Table 1—Number of Battery Cells Setting through CELL States

CELL	NUMBER OF CELLS
High	1 CELL(VIN=4.75-18V)
Low/Float	2 CELL(VIN=8.75-18V)

2. This board also can regulate the terminal battery voltage, by setting the logic of SEL pin. Table 2 shows how to set the terminal battery voltage spec through JP2 according to different application conditions.

Table 2—Terminal Battery Voltage Setting through SEL States

SEL	TERMINAL BATTERY VOLTAGE
High	4.1V/CELL
Low/Float	4.2V/CELL

3. JP3 is used to set the EN logic, which can control MP2615 to totally shutdown with VIN added. Logic high which means connect EN to VCC through JP3 can disable MP2615. Float it or connect it to GND can enable the part.

4. The constant charge current (I_{CC}) can be set by the sense resistor RS1 through the following formula:

$$I_{CC} (A) = 100(mV)/RS1(m\Omega)$$

If $RS1=50\ m\Omega$, $I_{CC} = 100(mV)/50(m\Omega) = 2A$.

Accordingly, the trickle charge current (I_{TC}) can be set by the following formula:

$$I_{TC} = 10\%I_{CC} = 10(mV)/RS1(m\Omega)$$

5. More detail application information please refer to the datasheet.

NOTICE: The information in this document is subject to change without notice. Users should warrant and guarantee that third party Intellectual Property rights are not infringed upon when integrating MPS products into any application. MPS will not assume any legal responsibility for any said applications.