

PRODUCT NUMBER BPS8B96FLD-00-----

WITH "LF" SUFFIX	LEAD FREE OR RoHS COMPATIBLE PRODUCT
WITHOUT SUFFIX	LEADED PRODUCT

WIRE ACCOMODATION		
PRODUCT NUMBER	WIRE SIZE	CONTACT IDENTIFICATION
BPS8B96FLD000--	AWG28/30	0
BPS8B96FLD200--	AWG24/26	2

CONTACT PLATING	
PLATING CODE	PERFORMANCE LEVEL PER DIN41612
Z0	CLASS 3
Z1	CLASS 2
E9	CLASS 1
L9	-

NOTES:-
 1. THE "LF" PRODUCTS MEET EUROPEAN UNION DIRECTIVES AND OTHER COUNTRY REGULATIONS AS DESCRIBED IN GS-22-008
 2. LEAD FREE OR RoHS DIRECTIVE LABELING TO BE PROVIDED AS PER GS-14-920 FOR RoHS COMPATIBLE VERSION.

PERFORMANCES CHARACTERISTICS

VOLTAGE RATING : 250 VAC (rms) OF INITIAL VALUE AFTER TEST.
 CURRENT RATING : 1,5 A AT 25 °C, 1 A AT 70 °C.
 INSULATION RESISTANCE : 1000MΩINITIAL, 100MΩMIN. AFTER TEST
 DIELECTRIC WITH-
 STANDING VOLTAGE : 1000 VAC (rms).
 CONTACT RESISTANCE : 15mΩMAX. INITIAL, 5mΩMAX. RISE
 OPERATING TEMPERATURE*: -40 °C TO +125 °C.
 INSERTION FORCE : 1 N MAX./CONTACT.
 WITHDRAWAL FORCE : 0,2 N MIN./CONTACT.

*DEPENDING ON THE CABLE, THE MAX. TEMPERATURE CAN BE LOWER.
 FOR STANDARD PVC INSULATED CABLE : 105 °C MAX.

CONSTRUCTION

BODY MATERIAL : GLASS-REINFORCED THERMOPLASTIC (UL94V-0).
 CONTACT MATERIAL : PHOSPHOR BRONZE.
 CONTACT FINISH : Au OVER Ni IN CONTACT AREA
 SnPb ON I.D.C. TERMINAL FOR LEADED PRODUCTS.
 Sn (MATTE TIN) ON I.D.C. TERMINAL FOR LEAD FREE PRODUCTS.

Z0 : PERFORMANCE LEVEL PER DIN41612 CLASS 3
 Z1 : PERFORMANCE LEVEL PER DIN41612 CLASS 2
 E9 : PERFORMANCE LEVEL PER DIN41612 CLASS 1
 L9 : 1.25 μm Au OVER NI

PART NUMBERS

BPS8B96FLD000----- CONNECTOR FOR WIRE SIZE AWG28, AWG30.
 (CONTACT IDENTIFICATION : 0).
 BPS8B96FLD200----- CONNECTOR FOR WIRE SIZE AWG24, AWG26
 (CONTACT IDENTIFICATION : 2).

AWG WIRE SIZE MARKING

BPS8B96FLD000-- : 28/30.
 BPS8B96FLD000--LF : 28/30.
 BPS8B96FLD200-- : 24/26.
 BPS8B96FLD200--LF : 24/26.

DATECODE MARKING

A + YEAR & WEEKCODE, EXAMPLE : A9950.

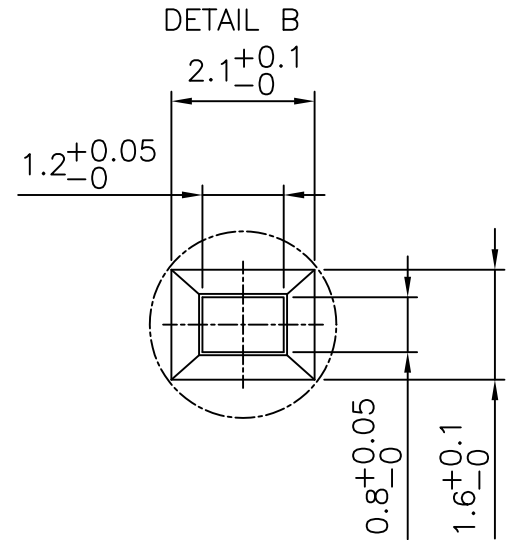
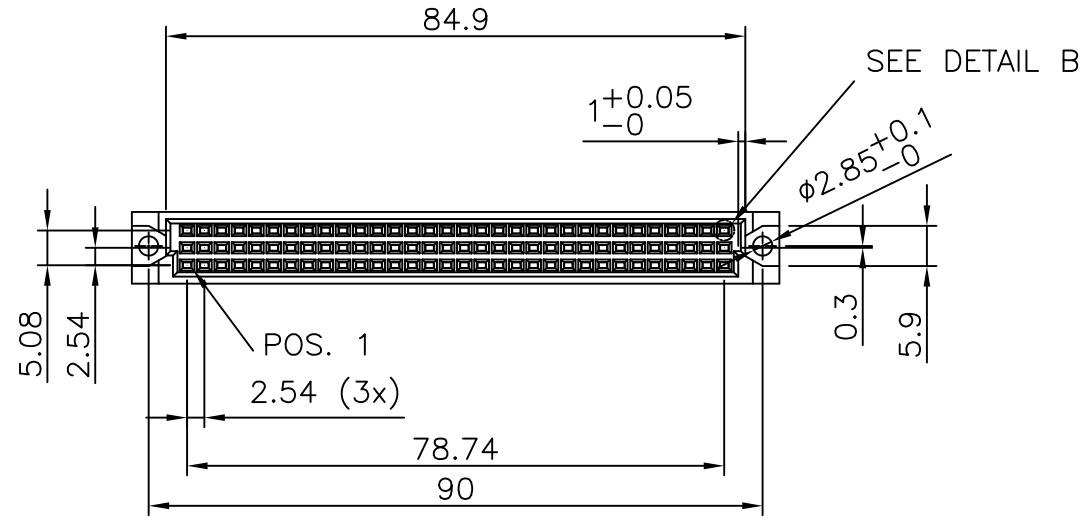
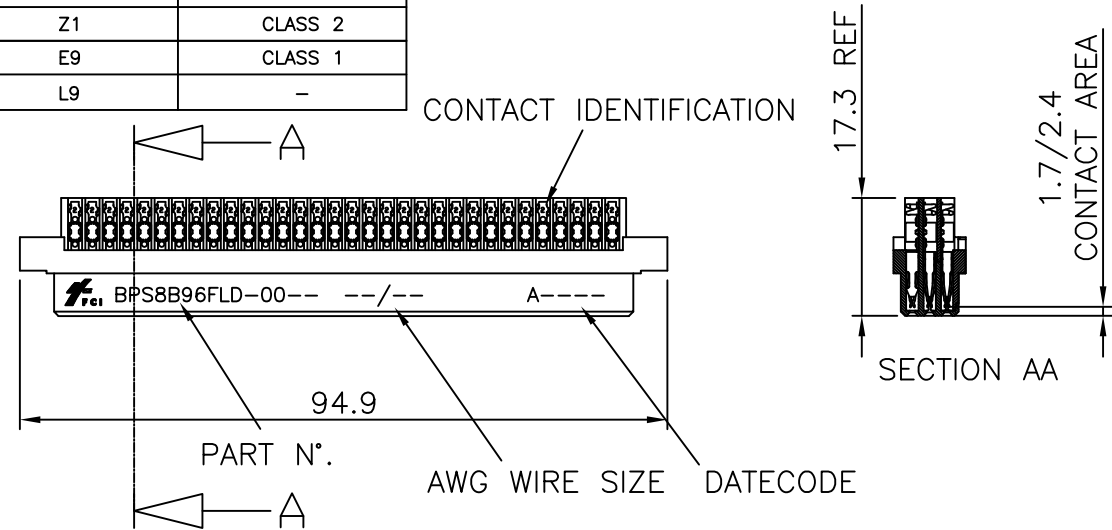
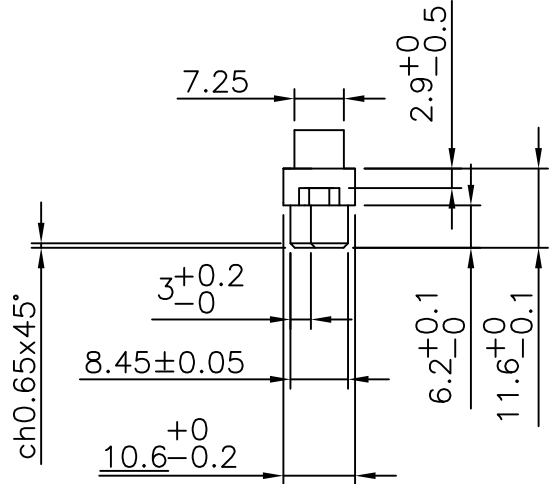

mat'l. code				surface		tolerance		projection		product family	
SEE NOTE				ISO 1302 ✓		ISO 406 ISO 1101		mm		BPS8	
tolerances unless otherwise specified				angles		linear		mm		title	
A F00819 DLE 2000-10-19				±1'		0.1±0.2		mm		ASSY BPS8	
B F00835 GCO 2000-11-09				±1'		0.01±0.1		mm		96 POS. A,B,C LOADED	
C I05-0123 MINI 2005-07-27				±1'		0.01±0.1		mm		dwg no	
D I06-0067 MINI 2006-06-01				dr		D.LEGRAND		2000-10-19		sheet 1 of 5 size	
E ELX-I-24377 MJA 2016-06-24				enr		J.F.NOTTEAU		2000-10-19		55365 A3	
F ELX-I-25060 MJA 2016-09-28				chr		M JACOB		2016-09-28		type	
				appd		BUJ K PAUL		2016-09-28		Product Customer Drawing	
sheet index		revision sheet		F	D	D	F	A			
				1	2	3	4	5			



Copyright FCI

NOTES:-
 1. THE "LF" PRODUCTS MEET EUROPEAN UNION DIRECTIVES AND OTHER COUNTRY REGULATIONS AS DESCRIBED IN GS-22-008
 2. LEAD FREE OR RoHS DIRECTIVE LABELING TO BE PROVIDED AS PER GS-14-920 FOR RoHS COMPATIBLE VERSION.

PERFORMANCES CHARACTERISTICS

VOLTAGE RATING : 250 VAC (rms)
 CURRENT RATING : 1,5 A AT 25 °C, 1 A AT 70 °C.
 INSULATION RESISTANCE : 1000MΩINITIAL, 100MΩMIN. AFTER TEST
 DIELECTRIC WITH-
 STANDING VOLTAGE : 1000 VAC (rms).
 CONTACT RESISTANCE : 15mΩMAX. INITIAL, 5mΩMAX. RISE OF INITIAL VALUE AFTER TEST.
 OPERATING TEMPERATURE*: -40 °C TO +125 °C.
 INSERTION FORCE : 1 N MAX./CONTACT.
 WITHDRAWAL FORCE : 0,2 N MIN./CONTACT.
 *DEPENDING ON THE CABLE, THE MAX. TEMPERATURE CAN BE LOWER.
 FOR STANDARD PVC INSULATED CABLE : 105 °C MAX.

CONSTRUCTION

BODY MATERIAL : GLASS-REINFORCED THERMOPLASTIC (UL94V-0).
 CONTACT MATERIAL : PHOSPHOR BRONZE.
 CONTACT FINISH : 1.25 μm Au MIN. OVER 2 μm Ni MIN. IN CONTACT AREA
 SnPb ON I.D.C. TERMINAL FOR LEADED PRODUCTS.
 Sn (MATTE TIN) ON I.D.C. TERMINAL FOR LEAD FREE PRODUCTS.

CABLE : 3M FLEXIBLE TWISTED PAIR CABLE (WIRES & CABLE) TYPE 3782 PER UL STYLE/20488 OR TYPE 3783 PER UL STYLE/2935.

PART NUMBERS
 BPS8B96FLD100L9-- CONNECTOR FOR WIRE SIZE AWG28 (CONTACT IDENTIFICATION : 1).

AWG WIRE SIZE MARKING
 BPS8B96FLD100L9 : 28.
 BPS8B96FLD100L9LF : 28.

DATECODE MARKING
 A + YEAR & WEEKCODE, EXAMPLE : A9950.

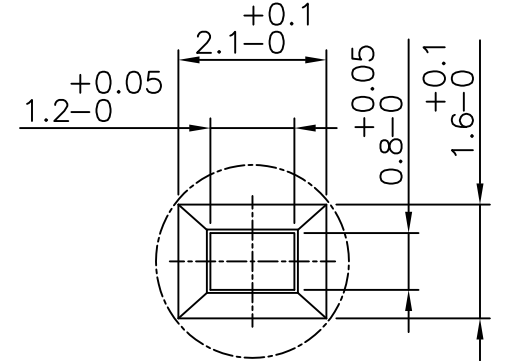
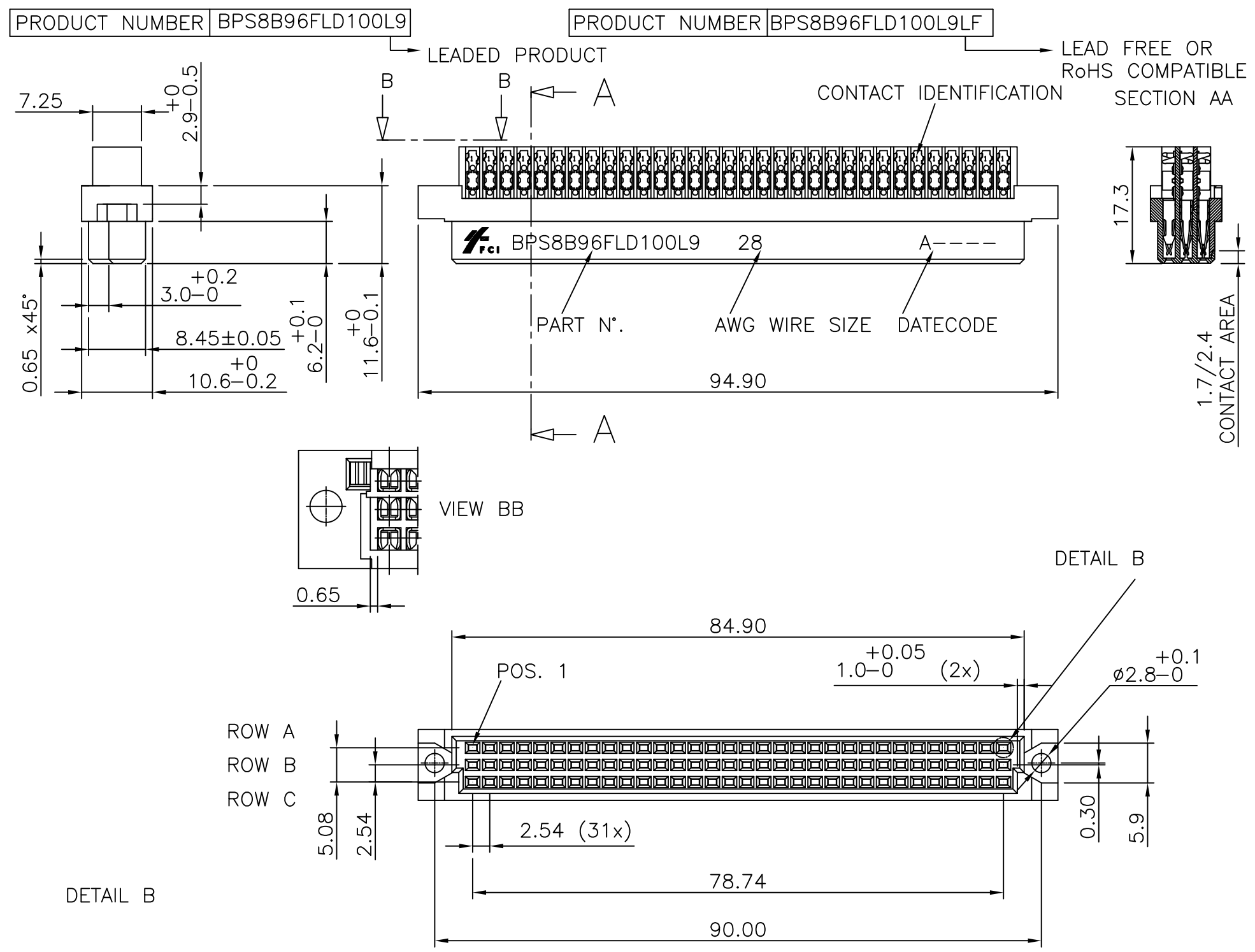

mat'l. code				surface		tolerance		projection		product family	
SEE NOTE				ISO 1302		ISO 406 ISO 1101		mm		BPS8	
ltr				ecn no		dr		date		title	
D				angles		linear		mm		ASSY BPS8	
				±0°30'				scale		96 POS. A,B,C LOADED	
				dr		D.LEGRAND		2000-10-20		dwg no	
				enr		J.F.NOTTEAU		2000-10-20		sheet 2 of 5	
				chr		RAKHEE GEORGE		2006-06-01		55365	
				appd		RAKHEE GEORGE		2006-06-01		A3	
sheet index				revision sheet						type	
										Product Customer Drawing	



Copyright FCI

PRODUCT NUMBER	BPS8B96FLD-C0----	WITH "LF" SUFFIX	LEAD FREE OR RoHS COMPATIBLE PRODUCT
		WITHOUT SUFFIX	LEADED PRODUCT

NOTES:-
 1. THE "LF" PRODUCTS MEET EUROPEAN UNION DIRECTIVES AND OTHER COUNTRY REGULATIONS AS DESCRIBED IN GS-22-008
 2. LEAD FREE OR RoHS DIRECTIVE LABELING TO BE PROVIDED AS PER GS-14-920 FOR RoHS COMPATIBLE VERSION.

WIRE ACCOMODATION		
PRODUCT NUMBER	WIRE SIZE	CONTACT IDENTIFICATION
BPS8B96FLD0C0--	AWG28/30	0
BPS8B96FLD2C0--	AWG24/26	2

CONTACT PLATING	
PLATING CODE	PERFORMANCE LEVEL PER DIN41612
Z0	CLASS 3
Z1	CLASS 2
E9	CLASS 1

PERFORMANCES CHARACTERISTICS

VOLTAGE RATING : 250 VAC (rms)
 CURRENT RATING : 1,5 A AT 25 °C, 1 A AT 70 °C.
 INSULATION RESISTANCE : 1000MΩINITIAL, 100MΩMIN. AFTER TEST
 DIELECTRIC WITHSTANDING VOLTAGE : 1000 VAC (rms).
 CONTACT RESISTANCE : 15mΩMAX. INITIAL, 5mΩMAX. RISE OF INITIAL VALUE AFTER TEST.
 OPERATING TEMPERATURE*: -40 °C TO +125 °C.
 INSERTION FORCE : 1 N MAX./CONTACT.
 WITHDRAWAL FORCE : 0,2 N MIN./CONTACT.

*DEPENDING ON THE CABLE, THE MAX. TEMPERATURE CAN BE LOWER.
 FOR STANDARD PVC INSULATED CABLE : 105 °C MAX.

CONSTRUCTION

BODY MATERIAL : GLASS-REINFORCED THERMOPLASTIC (UL94V-0).
 COVER MATERIAL : POLYPHENYLENE (PPO), COLOUR : BLACK.
 CONTACT MATERIAL : PHOSPHOR BRONZE.
 CONTACT FINISH : Au OVER Ni IN CONTACT AREA
 SnPb ON I.D.C. TERMINAL FOR LEADED PRODUCTS.
 Sn (MATTE TIN) ON I.D.C. TERMINAL FOR LEAD FREE PRODUCTS.
 Z0 : PERFORMANCE LEVEL PER DIN41612 CLASS 3
 Z1 : PERFORMANCE LEVEL PER DIN41612 CLASS 2
 E9 : PERFORMANCE LEVEL PER DIN41612 CLASS 1
 OTHERS : CONSULT FCI
 TIE-WRAP : OPTIONAL (PART N°. TF4)

PART NUMBERS

BPS8B96FLD0C0----CONNECTOR FOR WIRE SIZE AWG28, AWG30.
 (CONTACT IDENTIFICATION : 0).
 BPS8B96FLD2C0----CONNECTOR FOR WIRE SIZE AWG24, AWG26
 (CONTACT IDENTIFICATION : 2).

AWG WIRE SIZE MARKING

BPS8B96FLD0C0-- : 28/30.
 BPS8B96FLD0C0--LF : 28/30.
 BPS8B96FLD2C0-- : 24/26.
 BPS8B96FLD2C0--LF : 24/26.

DATECODE MARKING

A + YEAR & WEEKCODE, EXAMPLE : A9950.

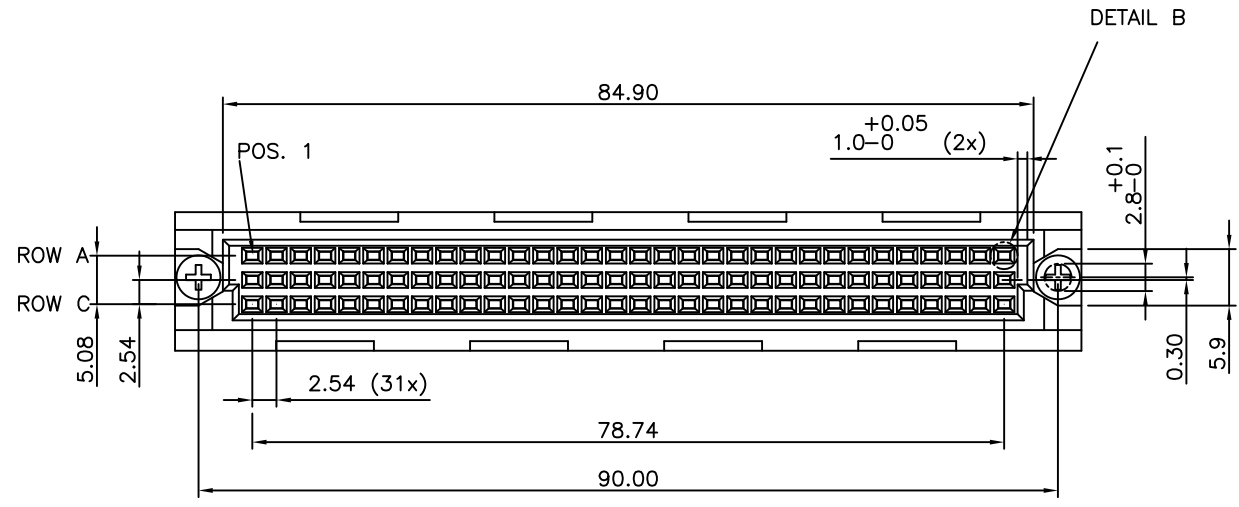
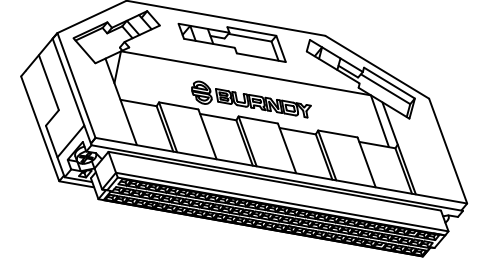
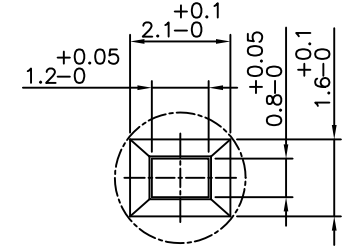
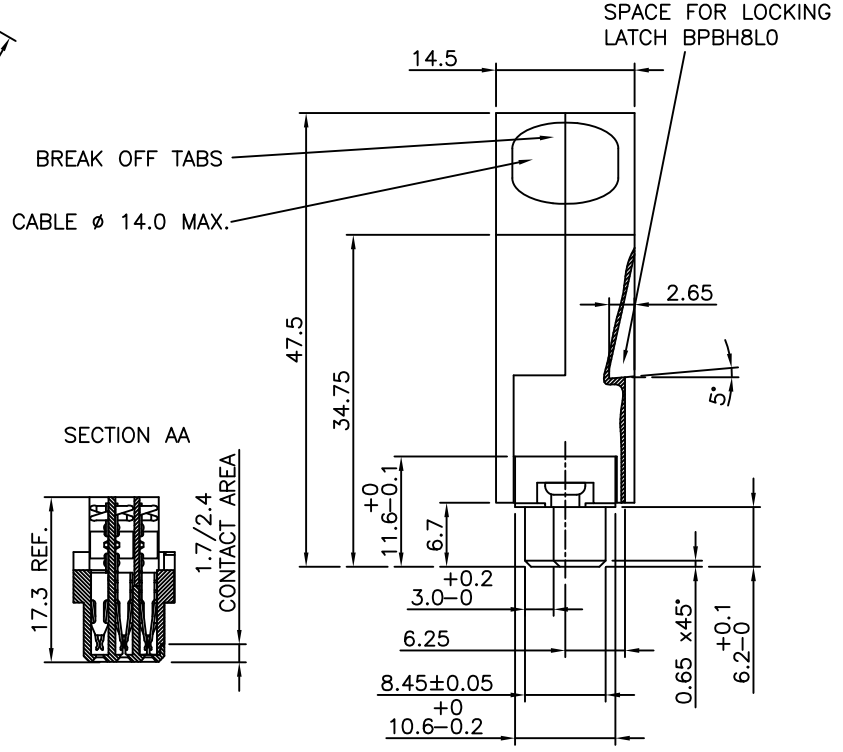
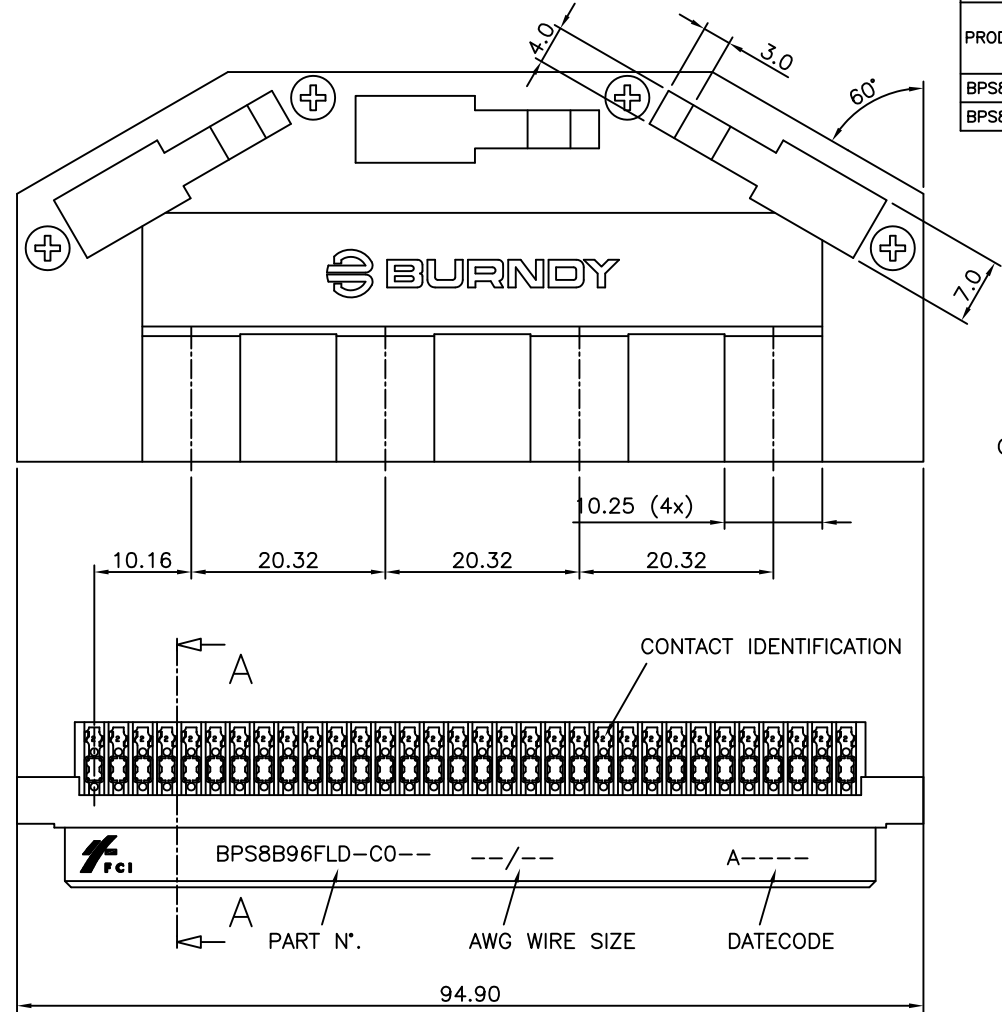

mat'l. code		surface		tolerance		projection		product family	
SEE NOTES		ISO 1302 ✓		ISO 406 ISO 1101		mm		BPS8	
ltr		ecn no		dr		date		title	
								ASSY BPS8	
d		angles		linear		scale		96 POS. A,B,C LOADED	
		±1°				-		dwg no	
				dr		D.LEGRAND		sheet 3 of 5	
				engr		J.F.NOTTEAU		size	
				chr		2000-10-23		A3	
				appd		2000-10-23		55365	
				appd		2006-06-01		type	
				appd		2006-06-01		Product Customer Drawing	
sheet index		revision sheet							



Copyright FCI

PRODUCT NUMBER BPS8B96ABD-00----

WITH "LF" SUFFIX	LEAD FREE OR RoHS COMPATIBLE PRODUCT
WITHOUT SUFFIX	LEADED PRODUCT

NOTES:-
 1. THE "LF" PRODUCTS MEET EUROPEAN UNION DIRECTIVES AND OTHER COUNTRY REGULATIONS AS DESCRIBED IN GS-22-008
 2. LEAD FREE OR RoHS DIRECTIVE LABELING TO BE PROVIDED AS PER GS-14-920 FOR RoHS COMPATIBLE VERSION.

WIRE ACCOMODATION		
PRODUCT NUMBER	WIRE SIZE	CONTACT IDENTIFICATION
BPS8B96ABD000--	AWG28/30	0
BPS8B96ABD200--	AWG24/26	2

CONTACT PLATING	
PLATING CODE	PERFORMANCE LEVEL PER DIN41612
Z0	CLASS 3
Z1	CLASS 2
E9	CLASS 1

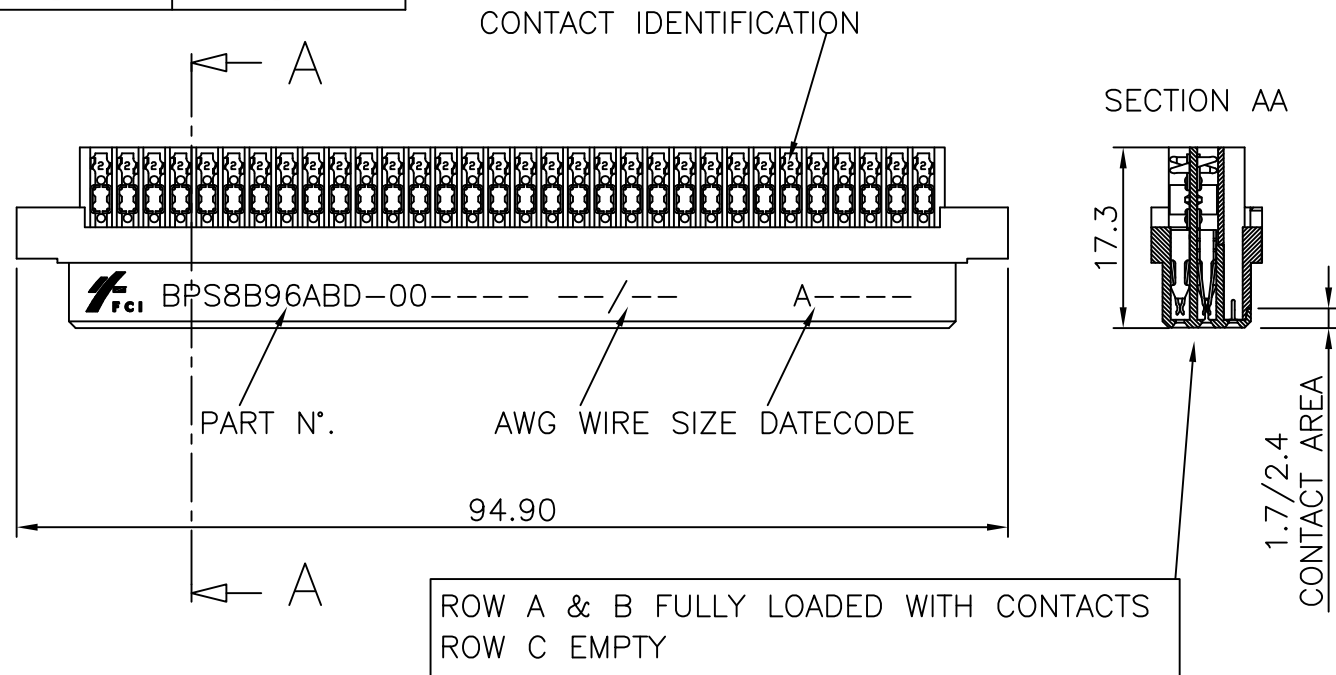
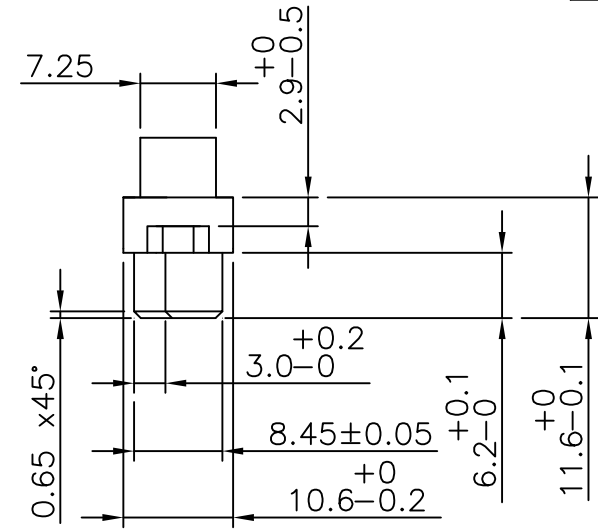

PERFORMANCES CHARACTERISTICS

VOLTAGE RATING : 250 VAC (rms)
 CURRENT RATING : 1,5 A AT 25 °C, 1 A AT 70 °C.
 INSULATION RESISTANCE : 1000MΩINITIAL, 100MΩMIN. AFTER TEST
 DIELECTRIC WITH-
 STANDING VOLTAGE : 1000 VAC (rms).
 CONTACT RESISTANCE : 15mΩMAX. INITIAL, 5mΩMAX. RISE OF INITIAL VALUE AFTER TEST.
 OPERATING TEMPERATURE*: -40 °C TO +125 °C.
 INSERTION FORCE : 1 N MAX./CONTACT.
 WITHDRAWAL FORCE : 0,2 N MIN./CONTACT.
 *DEPENDING ON THE CABLE, THE MAX. TEMPERATURE CAN BE LOWER. FOR STANDARD PVC INSULATED CABLE : 105 °C MAX.

CONSTRUCTION

BODY MATERIAL : GLASS-REINFORCED THERMOPLASTIC (UL94V-0).
 CONTACT MATERIAL : PHOSPHOR BRONZE.
 CONTACT FINISH : Au OVER Ni IN CONTACT AREA
 SnPb ON I.D.C. TERMINAL FOR LEADED PRODUCTS.
 Sn (MATTE TIN) ON I.D.C. TERMINAL FOR LEAD FREE PRODUCTS.
 Z0 : PERFORMANCE LEVEL PER DIN41612 CLASS 3
 Z1 : PERFORMANCE LEVEL PER DIN41612 CLASS 2
 E9 : PERFORMANCE LEVEL PER DIN41612 CLASS 1

PART NUMBERS

BPS8B96ABD000---- CONNECTOR FOR WIRE SIZE AWG28, AWG30 (CONTACT IDENTIFICATION : 0).
 BPS8B96ABD200---- CONNECTOR FOR WIRE SIZE AWG24, AWG26 (CONTACT IDENTIFICATION : 2).

AWG WIRE SIZE MARKING

BPS8B96ABD000-- : 28/30.
 BPS8B96ABD000--LF : 28/30.
 BPS8B96ABD200-- : 24/26.
 BPS8B96ABD200--LF : 24/26.

DATECODE MARKING

A + YEAR & WEEKCODE, EXAMPLE : A9950.

ROW A & B FULLY LOADED WITH CONTACTS
 ROW C EMPTY

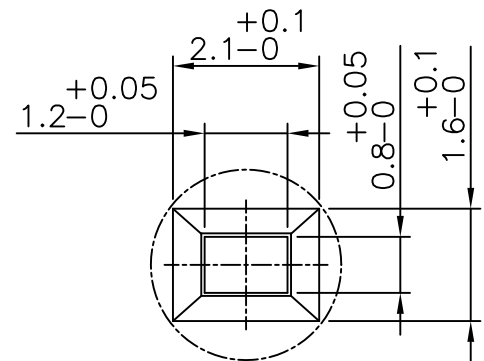
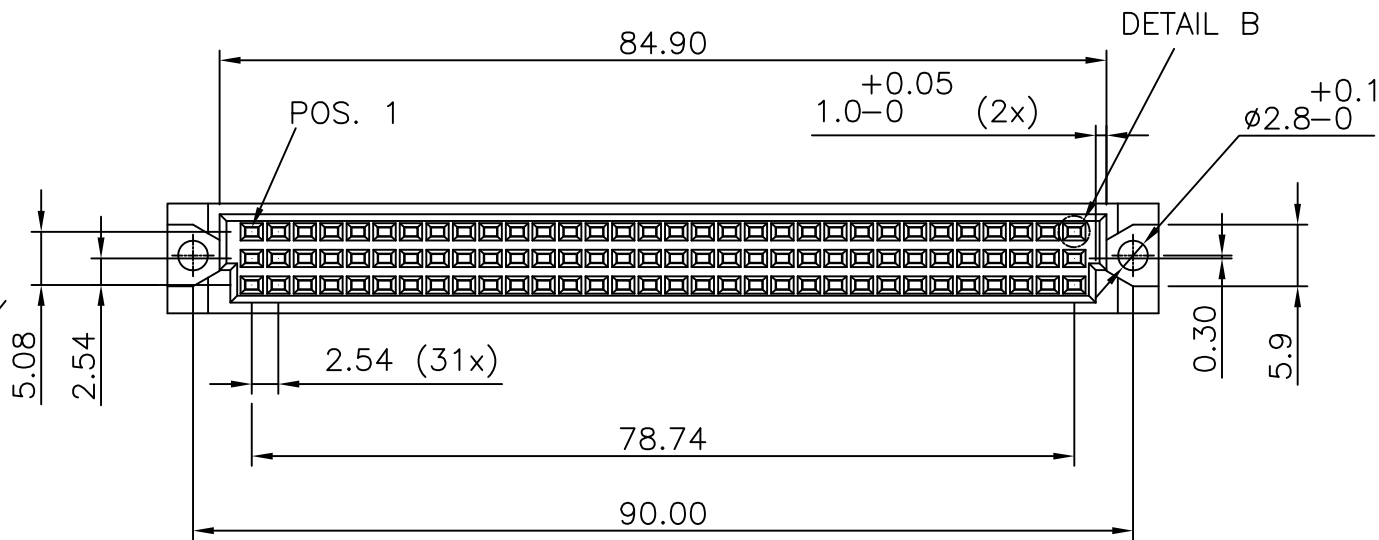

mat'l. code		surface		tolerance		projection		product family	
SEE NOTE		ISO 1302 ✓		ISO 406 ISO 1101		mm		BPS8	
ltr	ecn no	dr	date	tolerances unless otherwise specified		mm		title	
F				0.1±0.2		mm		ASSY BPS8	
				0.01±0.1		mm		96 POS. A,B LOADED	
				±1'		scale -		dwg no	
				dr D.LEGRAND		2000-10-20		sheet 4 of 5	
				enr J.F.NOTTEAU		2000-10-20		size	
				chr M JACOB		2016-09-28		A3	
				appd BIJU K PAUL		2016-09-28		type	
sheet index		revision sheet						Product Customer Drawing	

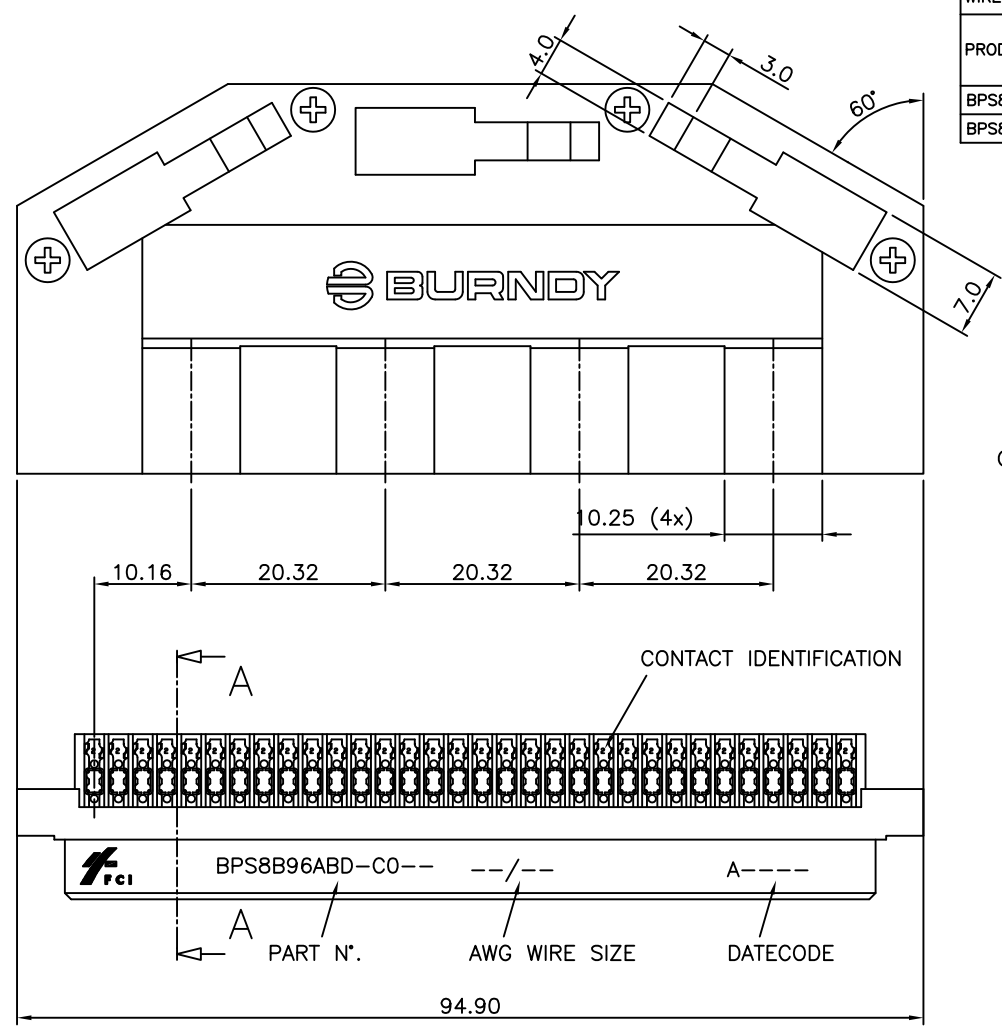

PRODUCT NUMBER		BPS8B96ABD-C0----	
WITH "LF" SUFFIX	LEAD FREE OR RoHS COMPATIBLE PRODUCT		
WITHOUT SUFFIX	LEADED PRODUCT		

WIRE ACCOMODATION		
PRODUCT NUMBER	WIRE SIZE	CONTACT IDENTIFICATION
BPS8B96ABD0C0--	AWG28/30	0
BPS8B96ABD2C0--	AWG24/26	2

CONTACT PLATING	
PLATING CODE	PERFORMANCE LEVEL PER DIN41612
Z0	CLASS 3
Z1	CLASS 2
E9	CLASS 1

NOTES:-
 1. THE "LF" PRODUCTS MEET EUROPEAN UNION DIRECTIVES AND OTHER COUNTRY REGULATIONS AS DESCRIBED IN GS-22-008
 2. LEAD FREE OR RoHS DIRECTIVE LABELING TO BE PROVIDED AS PER GS-14-920 FOR RoHS COMPATIBLE VERSION.

PERFORMANCES CHARACTERISTICS
 VOLTAGE RATING : 250 VAC (rms)
 CURRENT RATING : 1,5 A AT 25 °C, 1 A AT 70 °C.
 INSULATION RESISTANCE : 1000MΩINITIAL, 100MΩMIN. AFTER TEST
 DIELECTRIC WITHSTANDING VOLTAGE : 1000 VAC (rms).
 CONTACT RESISTANCE : 15mΩMAX. INITIAL, 5mΩMAX. RISE OF INITIAL VALUE AFTER TEST.
 OPERATING TEMPERATURE*: -40 °C TO +125 °C.
 INSERTION FORCE : 1 N MAX./CONTACT.
 WITHDRAWAL FORCE : 0,2 N MIN./CONTACT.

*DEPENDING ON THE CABLE, THE MAX. TEMPERATURE CAN BE LOWER. FOR STANDARD PVC INSULATED CABLE : 105 °C MAX.

CONSTRUCTION
 BODY MATERIAL : GLASS-REINFORCED THERMOPLASTIC (UL94V-0).
 COVER MATERIAL : POLYPHENYLENE (PPO), COLOUR : BLACK.
 CONTACT MATERIAL : PHOSPHOR BRONZE.
 CONTACT FINISH : Au OVER Ni IN CONTACT AREA
 SnPb ON I.D.C. TERMINAL FOR LEADED PRODUCTS.
 Sn (MATTE TIN) ON I.D.C. TERMINAL FOR LEAD FREE PRODUCTS.
 Z0 : PERFORMANCE LEVEL PER DIN41612 CLASS 3
 Z1 : PERFORMANCE LEVEL PER DIN41612 CLASS 2
 E9 : PERFORMANCE LEVEL PER DIN41612 CLASS 1
 OTHERS : CONSULT FCI
 TIE-WRAP : OPTIONAL (PART N°. TF4)

PART NUMBERS
 BPS8B96ABD0C0----CONNECTOR FOR WIRE SIZE AWG28, AWG30. (CONTACT IDENTIFICATION : 0).
 BPS8B96ABD2C0----CONNECTOR FOR WIRE SIZE AWG24, AWG26 (CONTACT IDENTIFICATION : 2).

AWG WIRE SIZE MARKING
 BPS8B96ABD0C0-- : 28/30.
 BPS8B96ABD0C0--LF : 28/30.
 BPS8B96ABD2C0-- : 24/26.
 BPS8B96ABD2C0--LF : 24/26.

DATECODE MARKING
 A + YEAR & WEEKCODE, EXAMPLE : A9950.

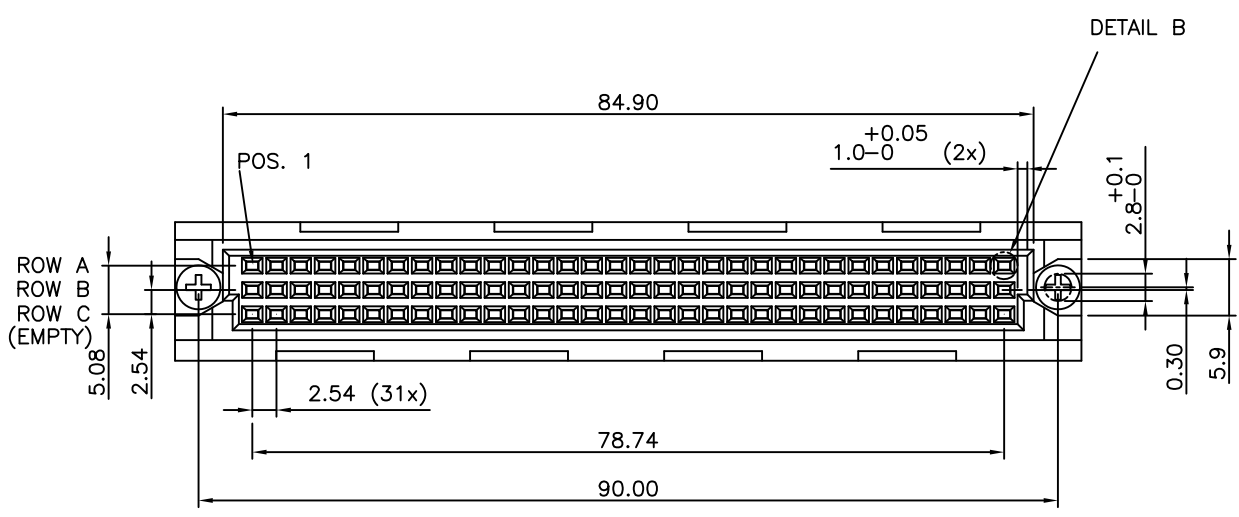
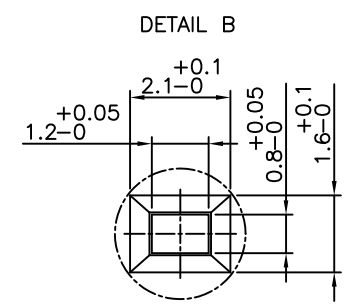
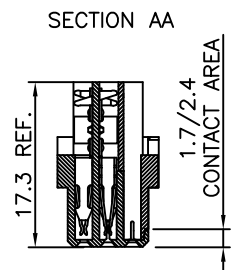
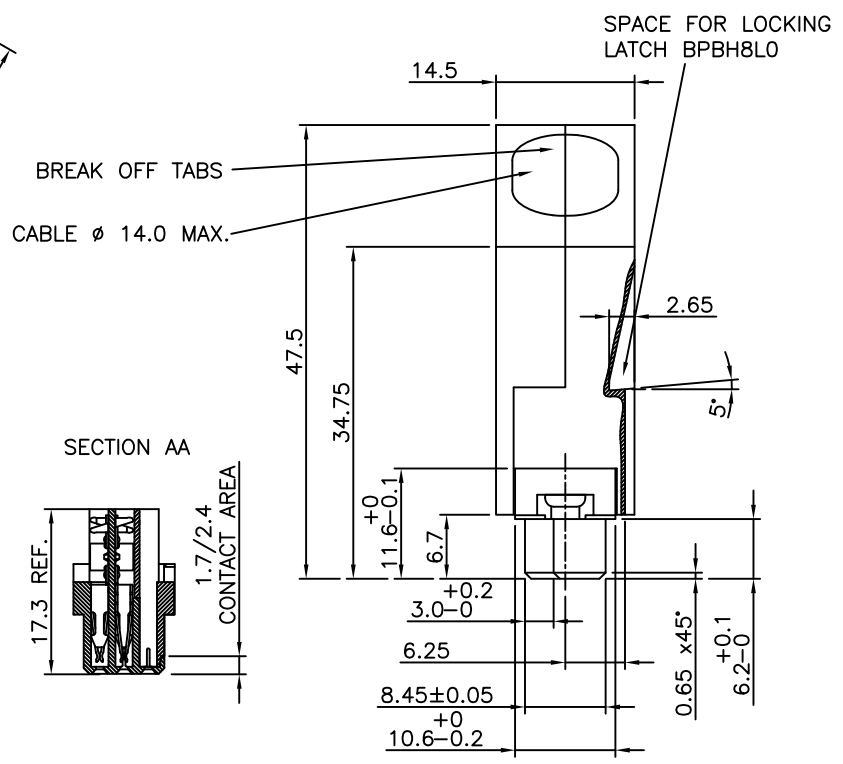
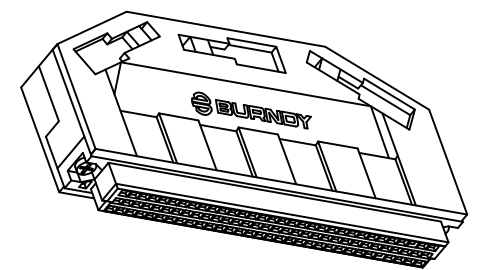

mat'l. code		surface		tolerance		projection		product family	
SEE NOTES		ISO 1302 ✓		ISO 406 ISO 1101		mm		BPS8	
ltr		ecn no		dr		date		title	
A								ASSY BPS8	
								96 POS. A,B LOADED	
								dwg no	
								55365	
								sheet 5 of 5	
								size	
								A3	
								type	
								Product Customer Drawing	
sheet index		revision sheet							