



High Performance 8-Bit Microcontrollers

**Z8 Encore! XP[®] 64K Series
Flash Microcontrollers**

Product Specification

PS019919-1207



Warning: DO NOT USE IN LIFE SUPPORT

LIFE SUPPORT POLICY

ZILOG'S PRODUCTS ARE NOT AUTHORIZED FOR USE AS CRITICAL COMPONENTS IN LIFE SUPPORT DEVICES OR SYSTEMS WITHOUT THE EXPRESS PRIOR WRITTEN APPROVAL OF THE PRESIDENT AND GENERAL COUNSEL OF ZILOG CORPORATION.

As used herein

Life support devices or systems are devices which (a) are intended for surgical implant into the body, or (b) support or sustain life and whose failure to perform when properly used in accordance with instructions for use provided in the labeling can be reasonably expected to result in a significant injury to the user. A critical component is any component in a life support device or system whose failure to perform can be reasonably expected to cause the failure of the life support device or system or to affect its safety or effectiveness.

Document Disclaimer

©2007 by Zilog, Inc. All rights reserved. Information in this publication concerning the devices, applications, or technology described is intended to suggest possible uses and may be superseded. ZILOG, INC. DOES NOT ASSUME LIABILITY FOR OR PROVIDE A REPRESENTATION OF ACCURACY OF THE INFORMATION, DEVICES, OR TECHNOLOGY DESCRIBED IN THIS DOCUMENT. ZILOG ALSO DOES NOT ASSUME LIABILITY FOR INTELLECTUAL PROPERTY INFRINGEMENT RELATED IN ANY MANNER TO USE OF INFORMATION, DEVICES, OR TECHNOLOGY DESCRIBED HEREIN OR OTHERWISE. The information contained within this document has been verified according to the general principles of electrical and mechanical engineering.

Z8, Z8 Encore!, Z8 Encore! XP, Z8 Encore! MC, Crimzon, eZ80, and ZNEO are trademarks or registered trademarks of Zilog, Inc. All other product or service names are the property of their respective owners.



**ISO 9001:2000
FS 507510**

Zilog products are designed and manufactured under an ISO registered 9001:2000 Quality Management System. For more details, please visit www.zilog.com/quality.



Revision History

Each instance in the Revision History reflects a change to this document from its previous revision. For more details, refer to the corresponding pages or appropriate links given in the table below.

Date	Revision Level	Description	Page No
December 2007	19	Updated Zilog logo, Disclaimer section, and implemented style guide. Updated Table 112 . Changed Z8 Encore! 64K Series to Z8 Encore! XP 64K Series Flash Microcontrollers throughout the document.	All
December 2006	18	Updated Table 110 and Ordering Information .	228 , 270
November 2006	17	Updated Part Number Suffix Designations .	275
June 2006	16	Updated Timer 0-3 Control 1 Registers .	94
October 2005	15	The paragraph tag for Ordering Information has been changed from H1 Heading to Chapter Title.	270



Table of Contents

Manual Objectives	xii
About This Manual	xii
Intended Audience	xii
Manual Conventions	xii
Safeguards	xiv
Introduction	1
Features	1
Part Selection Guide	2
Block Diagram	3
CPU and Peripheral Overview	3
eZ8 [™] CPU Features	3
General-Purpose Input/Output	4
Flash Controller	4
10-Bit Analog-to-Digital Converter	4
UARTs	4
I ² C	5
Serial Peripheral Interface	5
Timers	5
Interrupt Controller	5
Reset Controller	5
On-Chip Debugger	5
DMA Controller	5
Signal and Pin Descriptions	7
Overview	7
Available Packages	7
Pin Configurations	8
Signal Descriptions	14
Pin Characteristics	16
Address Space	19
Overview	19
Register File	19
Program Memory	20
Data Memory	21



Information Area	21
Register File Address Map	23
Control Register Summary	28
Reset and Stop Mode Recovery	47
Overview	47
Reset Types	47
Reset Sources	48
Power-On Reset	49
Voltage Brownout Reset	50
Watchdog Timer Reset	51
External Pin Reset	51
On-Chip Debugger Initiated Reset	52
Stop Mode Recovery	52
Stop Mode Recovery Using Watchdog Timer Time-Out	52
Stop Mode Recovery Using a GPIO Port Pin Transition HALT	53
Low-Power Modes	55
Overview	55
STOP Mode	55
HALT Mode	56
General-Purpose I/O	57
Overview	57
GPIO Port Availability By Device	57
Architecture	58
GPIO Alternate Functions	59
GPIO Interrupts	60
GPIO Control Register Definitions	61
Port A–H Address Registers	61
Port A–H Control Registers	62
Port A–H Input Data Registers	66
Port A–H Output Data Register	66
Interrupt Controller	67
Overview	67
Interrupt Vector Listing	67
Architecture	69
Operation	69



Master Interrupt Enable	69
Interrupt Vectors and Priority	70
Interrupt Assertion	70
Software Interrupt Assertion	70
Interrupt Control Register Definitions	71
Interrupt Request 0 Register	71
Interrupt Request 1 Register	72
Interrupt Request 2 Register	73
IRQ0 Enable High and Low Bit Registers	74
IRQ1 Enable High and Low Bit Registers	75
IRQ2 Enable High and Low Bit Registers	76
Interrupt Edge Select Register	78
Interrupt Port Select Register	78
Interrupt Control Register	79
Timers	81
Overview	81
Architecture	81
Operation	82
Timer Operating Modes	82
Reading the Timer Count Values	90
Timer Output Signal Operation	90
Timer Control Register Definitions	90
Timer 0-3 High and Low Byte Registers	90
Timer Reload High and Low Byte Registers	91
Timer 0-3 PWM High and Low Byte Registers	92
Timer 0-3 Control 0 Registers	93
Timer 0-3 Control 1 Registers	94
Watchdog Timer	97
Overview	97
Operation	97
Watchdog Timer Refresh	98
Watchdog Timer Time-Out Response	98
Watchdog Timer Reload Unlock Sequence	99
Watchdog Timer Control Register Definitions	100
Watchdog Timer Control Register	100
Watchdog Timer Reload Upper, High and Low Byte Registers	101



UART	103
Overview	103
Architecture	103
Operation	104
Data Format	104
Transmitting Data using the Polled Method	105
Transmitting Data using the Interrupt-Driven Method	106
Receiving Data using the Polled Method	107
Receiving Data using the Interrupt-Driven Method	108
Clear To Send (CTS) Operation	109
MULTIPROCESSOR (9-bit) Mode	109
External Driver Enable	110
UART Interrupts	111
UART Baud Rate Generator	113
UART Control Register Definitions	114
UART Transmit Data Register	114
UART Receive Data Register	115
UART Status 0 Register	115
UART Status 1 Register	116
UART Control 0 and Control 1 Registers	117
UART Address Compare Register	120
UART Baud Rate High and Low Byte Registers	120
Infrared Encoder/Decoder	125
Overview	125
Architecture	125
Operation	126
Transmitting IrDA Data	126
Receiving IrDA Data	127
Infrared Encoder/Decoder Control Register Definitions	128
Serial Peripheral Interface	129
Overview	129
Architecture	129
Operation	130
SPI Signals	131
SPI Clock Phase and Polarity Control	132
Multi-Master Operation	134
Slave Operation	134



Error Detection	135
SPI Interrupts	135
SPI Baud Rate Generator	136
SPI Control Register Definitions	137
SPI Data Register	137
SPI Control Register	137
SPI Status Register	139
SPI Mode Register	140
SPI Diagnostic State Register	141
SPI Baud Rate High and Low Byte Registers	142
I2C Controller	143
Overview	143
Architecture	144
Operation	144
SDA and SCL Signals	145
I ² C Interrupts	145
Software Control of I2C Transactions	146
Start and Stop Conditions	147
Master Write and Read Transactions	147
Address Only Transaction with a 7-bit Address	148
Write Transaction with a 7-Bit Address	149
Address Only Transaction with a 10-bit Address	150
Write Transaction with a 10-Bit Address	151
Read Transaction with a 7-Bit Address	153
Read Transaction with a 10-Bit Address	154
I2C Control Register Definitions	156
I2C Data Register	156
I2C Status Register	157
I2C Control Register	158
I2C Baud Rate High and Low Byte Registers	160
I2C Diagnostic State Register	161
I2C Diagnostic Control Register	163
Direct Memory Access Controller	165
Overview	165
Operation	165
DMA0 and DMA1 Operation	165
Configuring DMA0 and DMA1 for Data Transfer	166



DMA_ADC Operation	166
Configuring DMA_ADC for Data Transfer	167
DMA Control Register Definitions	167
DMAx Control Register	167
DMAx I/O Address Register	168
DMAx Address High Nibble Register	169
DMAx Start/Current Address Low Byte Register	170
DMAx End Address Low Byte Register	170
DMA_ADC Address Register	171
DMA_ADC Control Register	172
DMA Status Register	173
Analog-to-Digital Converter	175
Overview	175
Architecture	175
Operation	176
Automatic Power-Down	176
Single-Shot Conversion	177
Continuous Conversion	177
DMA Control of the ADC	178
ADC Control Register Definitions	179
ADC Control Register	179
ADC Data High Byte Register	180
ADC Data Low Bits Register	180
Flash Memory	183
Overview	183
Information Area	185
Operation	185
Timing Using the Flash Frequency Registers	186
Flash Read Protection	186
Flash Write/Erase Protection	186
Byte Programming	187
Page Erase	188
Mass Erase	189
Flash Controller Bypass	189
Flash Controller Behavior in Debug Mode	189
Flash Control Register Definitions	190
Flash Control Register	190



Flash Status Register	190
Page Select Register	191
Flash Sector Protect Register	192
Flash Frequency High and Low Byte Registers	192
Option Bits	195
Overview	195
Operation	195
Option Bit Configuration By Reset	195
Option Bit Address Space	195
Flash Memory Address 0000H	196
Flash Memory Address 0001H	197
On-Chip Debugger	199
Overview	199
Architecture	199
Operation	200
OCD Interface	200
DEBUG Mode	201
OCD Data Format	202
OCD Auto-Baud Detector/Generator	202
OCD Serial Errors	203
Breakpoints	203
On-Chip Debugger Commands	204
On-Chip Debugger Control Register Definitions	209
OCD Control Register	209
OCD Status Register	210
On-Chip Oscillator	211
Overview	211
Operating Modes	211
Crystal Oscillator Operation	211
Oscillator Operation with an External RC Network	213
Electrical Characteristics	215
Absolute Maximum Ratings	215
DC Characteristics	217
On-Chip Peripheral AC and DC Electrical Characteristics	226
AC Characteristics	231
General-Purpose I/O Port Input Data Sample Timing	232



General-Purpose I/O Port Output Timing	233
On-Chip Debugger Timing	234
SPI Master Mode Timing	235
SPI Slave Mode Timing	236
I2C Timing	237
UART Timing	238
eZ8[™] CPU Instruction Set	241
Assembly Language Programming Introduction	241
Assembly Language Syntax	242
eZ8 CPU Instruction Notation	242
Condition Codes	244
eZ8 CPU Instruction Classes	245
eZ8 CPU Instruction Summary	250
Flags Register	259
Opcode Maps	261
Packaging	265
Ordering Information	270
Part Number Suffix Designations	275
Index	277
Customer Support	287

Manual Objectives

This Product Specification provides detailed operating information for the Flash devices within Zilog's Z8 Encore! XP[®] 64K Series Flash Microcontrollers Microcontroller (MCU) products. Within this document, the Z8F642x, Z8F482x, Z8F322x, Z8F242x, and Z8F162x devices are referred to collectively as the Z8 Encore! XP[®] 64K Series Flash Microcontrollers unless specifically stated otherwise.

About This Manual

Zilog[®] recommends that you read and understand everything in this manual before setting up and using the product. However, we recognize that there are different styles of learning. Therefore, we have designed this Product Specification to be used either as a *how to* procedural manual or a reference guide to important data.

Intended Audience

This document is written for Zilog customers who are experienced at working with micro-controllers, integrated circuits, or printed circuit assemblies.

Manual Conventions

The following assumptions and conventions are adopted to provide clarity and ease of use:

Courier Typeface

Commands, code lines and fragments, bits, equations, hexadecimal addresses, and various executable items are distinguished from general text by the use of the `Courier` typeface. Where the use of the font is not indicated, as in the Index, the name of the entity is presented in upper case.

- Example: `FLAGS[1]` is `smrf`.

Hexadecimal Values

Hexadecimal values are designated by uppercase *H* suffix and appear in the `Courier` typeface.

- Example: R1 is set to `F8H`.

Brackets

The square brackets, `[]`, indicate a register or bus.

- Example: For the register `R1[7:0]`, R1 is an 8-bit register, `R1[7]` is the most significant bit, and `R1[0]` is the least significant bit.

Braces

The curly braces, { }, indicate a single register or bus created by concatenating some combination of smaller registers, buses, or individual bits.

- Example: The 12-bit register address {0H, RP[7:4], R1[3:0]} is composed of a 4-bit hexadecimal value (0H) and two 4-bit register values taken from the Register Pointer (RP) and Working Register R1. 0H is the most-significant nibble (4-bit value) of the 12-bit register, and R1[3:0] is the least significant nibble of the 12-bit register.

Parentheses

The parentheses, (), indicate an indirect register address lookup.

- Example: (R1) is the memory location referenced by the address contained in the Working Register R1.

Parentheses/Bracket Combinations

The parentheses, (), indicate an indirect register address lookup and the square brackets, [], indicate a register or bus.

- Example: Assume PC[15:0] contains the value 1234h. (PC[15:0]) then refers to the contents of the memory location at address 1234h.

Use of the Words *Set*, *Reset* and *Clear*

The word *set* implies that a register bit or a condition contains a logical 1. The words *reset* or *clear* imply that a register bit or a condition contains a logical 0. When either of these terms is followed by a number, the word *logical* may not be included; however, it is implied.

Notation for Bits and Similar Registers

A field of bits within a register is designated as: Register[n:n].

- Example: ADDR[15:0] refers to bits 15 through bit 0 of the Address.

Use of the Terms *LSB*, *MSB*, *lsb*, and *msb*

In this document, the terms *LSB* and *MSB*, when appearing in upper case, mean *least significant byte* and *most significant byte*, respectively. The lowercase forms, *lsb* and *msb*, mean *least significant bit* and *most significant bit*, respectively.

Use of Initial Uppercase Letters

Initial uppercase letters designate settings and conditions in general text.

- Example 1: The receiver forces the SCL line to Low.
- Example 2: The Master can generate a Stop condition to abort the transfer.

Use of All Uppercase Letters

The use of all uppercase letters designates the names of states, modes, and commands.

- Example 1: The bus is considered BUSY after the Start condition.
- Example 2: A START command triggers the processing of the initialization sequence.
- Example 3: STOP mode.

Bit Numbering

Bits are numbered from 0 to $n-1$ where n indicates the total number of bits. For example, the 8 bits of a register are numbered from 0 to 7.

Safeguards

It is important that you understand the following safety terms, which are defined here.



Caution:

Indicates a procedure or file may become corrupted if you do not follow directions.

Introduction

Zilog's Z8 Encore! XP MCU family of products are a line of Zilog[®] microcontroller products based upon the 8-bit eZ8 CPU. The Z8 Encore! XP[®] 64K Series Flash Microcontrollers, hereafter referred to collectively as the Z8 Encore! XP or the 64K Series adds Flash memory to Zilog's extensive line of 8-bit microcontrollers. The Flash in-circuit programming capability allows for faster development time and program changes in the field. The new eZ8[™] CPU is upward compatible with existing Z8[®] instructions. The rich-peripheral set of the Z8 Encore! XP makes it suitable for a variety of applications including motor control, security systems, home appliances, personal electronic devices, and sensors.

Features

The features of Z8 Encore! XP 64K Series Flash Microcontrollers include:

- 20 MHz eZ8 CPU
- Up to 64 KB Flash with in-circuit programming capability
- Up to 4 KB register RAM
- 12-channel, 10-bit Analog-to-Digital Converter (ADC)
- Two full-duplex 9-bit UARTs with bus transceiver Driver Enable control
- Inter-integrated circuit (I²C)
- Serial Peripheral Interface (SPI)
- Two Infrared Data Association (IrDA)-compliant infrared encoder/decoders
- Up to four 16-bit timers with capture, compare, and PWM capability
- Watchdog Timer (WDT) with internal RC oscillator
- Three-channel DMA
- Up to 60 input/output (I/O) pins
- 24 interrupts with configurable priority
- On-Chip Debugger
- Voltage Brownout (VBO) Protection
- Power-On Reset (POR)
- Operating voltage of 3.0 V to 3.6 V with 5 V-tolerant inputs
- 0 °C to +70 °C, -40 °C to +105 °C, and -40 °C to +125 °C operating temperature ranges



Part Selection Guide

Table 1 identifies the basic features and package styles available for each device within the Z8 Encore! XP product line.

Table 1. Z8 Encore! XP 64K Series Flash Microcontrollers Part Selection Guide

Part Number	Flash (KB)	RAM (KB)	I/O	16-bit Timers with PWM	ADC Inputs	UARTs with IrDA	I ² C	SPI	40/44-pin packages	64/68-pin packages	80-pin package
Z8F1621	16	2	31	3	8	2	1	1	X		
Z8F1622	16	2	46	4	12	2	1	1		X	
Z8F2421	24	2	31	3	8	2	1	1	X		
Z8F2422	24	2	46	4	12	2	1	1		X	
Z8F3221	32	2	31	3	8	2	1	1	X		
Z8F3222	32	2	46	4	12	2	1	1		X	
Z8F4821	48	4	31	3	8	2	1	1	X		
Z8F4822	48	4	46	4	12	2	1	1		X	
Z8F4823	48	4	60	4	12	2	1	1			X
Z8F6421	64	4	31	3	8	2	1	1	X		
Z8F6422	64	4	46	4	12	2	1	1		X	
Z8F6423	64	4	60	4	12	2	1	1			X
Die Form Sales	Contact Zilog [®]										

Block Diagram

Figure 1 displays the block diagram of the architecture of the Z8 Encore! XP 64K Series Flash Microcontrollers.

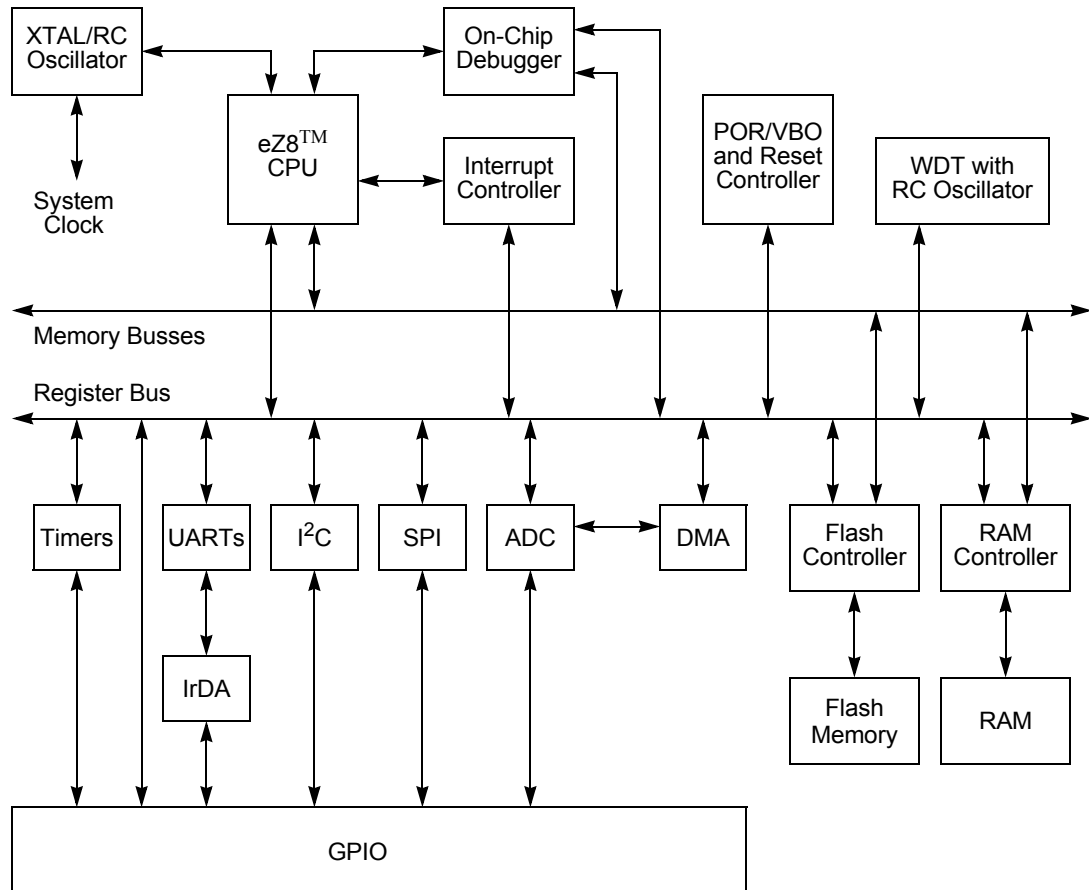

Figure 1. Z8 Encore! XP 64K Series Flash Microcontrollers Block Diagram

CPU and Peripheral Overview

eZ8™ CPU Features

The latest 8-bit eZ8 CPU meets the continuing demand for faster and more code-efficient microcontrollers. The eZ8 CPU executes a superset of the original Z8[®] instruction set.

The eZ8 CPU features include:

- Direct register-to-register architecture allows each register to function as an accumulator, improving execution time and decreasing the required Program Memory
- Software stack allows much greater depth in subroutine calls and interrupts than hardware stacks
- Compatible with existing Z8 code
- Expanded internal Register File allows access of up to 4 KB
- New instructions improve execution efficiency for code developed using higher-level programming languages, including C
- Pipelined instruction fetch and execution
- New instructions for improved performance including BIT, BSWAP, BTJ, CPC, LDC, LDCI, LEA, MULT, and SRL
- New instructions support 12-bit linear addressing of the Register File
- Up to 10 MIPS operation
- C-Compiler friendly
- 2 to 9 clock cycles per instruction

For more information on the eZ8 CPU, refer to *eZ8[™] CPU Core User Manual (UM0128)* available for download at www.zilog.com.

General-Purpose Input/Output

The 64K Series features seven 8-bit ports (Ports A-G) and one 4-bit port (Port H) for general-purpose input/output (GPIO). Each pin is individually programmable. All ports (except B and H) support 5 V-tolerant inputs.

Flash Controller

The Flash Controller programs and erases the Flash memory.

10-Bit Analog-to-Digital Converter

The Analog-to-Digital Converter converts an analog input signal to a 10-bit binary number. The ADC accepts inputs from up to 12 different analog input sources.

UARTs

Each UART is full-duplex and capable of handling asynchronous data transfers. The UARTs support 8- and 9-bit data modes, selectable parity, and an efficient bus transceiver Driver Enable signal for controlling a multi-transceiver bus, such as RS-485.

I²C

The I²C controller makes the Z8 Encore! XP compatible with the I²C protocol. The I²C controller consists of two bidirectional bus lines, a serial data (SDA) line and a serial clock (SCL) line.

Serial Peripheral Interface

The serial peripheral interface allows the Z8 Encore! XP to exchange data between other peripheral devices such as EEPROMs, A/D converters and ISDN devices. The SPI is a full-duplex, synchronous, character-oriented channel that supports a four-wire interface.

Timers

Up to four 16-bit reloadable timers can be used for timing/counting events or for motor control operations. These timers provide a 16-bit programmable reload counter and operate in One-Shot, Continuous, Gated, Capture, Compare, Capture and Compare, and PWM modes. Only 3 timers (Timers 0-2) are available in the 44-pin packages.

Interrupt Controller

The 64K Series products support up to 24 interrupts. These interrupts consist of 12 internal and 12 GPIO pins. The interrupts have 3 levels of programmable interrupt priority.

Reset Controller

The Z8 Encore! can be reset using the $\overline{\text{RESET}}$ pin, Power-On Reset, Watchdog Timer, STOP mode exit, or Voltage Brownout (VBO) warning signal.

On-Chip Debugger

The Z8 Encore! XP features an integrated On-Chip Debugger. The OCD provides a rich set of debugging capabilities, such as reading and writing registers, programming the Flash, setting breakpoints and executing code. A single-pin interface provides communication to the OCD.

DMA Controller

The 64K Series features three channels of DMA. Two of the channels are for register RAM to and from I/O operations. The third channel automatically controls the transfer of data from the ADC to the memory.



Signal and Pin Descriptions

Overview

The Z8 Encore! XP 64K Series Flash Microcontrollers product are available in a variety of packages styles and pin configurations. This chapter describes the signals and available pin configurations for each of the package styles. For information on physical package specifications, see [Packaging](#) on page 265.

Available Packages

[Table 2](#) identifies the package styles that are available for each device within the Z8 Encore! XP 64K Series Flash Microcontrollers product line.

Table 2. Z8 Encore! XP 64K Series Flash Microcontrollers Package Options

Part Number	40-Pin PDIP	44-pin LQFP	44-pin PLCC	64-pin LQFP	68-pin PLCC	80-pin QFP
Z8F1621	X	X	X			
Z8F1622				X	X	
Z8F2421	X	X	X			
Z8F2422				X	X	
Z8F3221	X	X	X			
Z8F3222				X	X	
Z8F4821	X	X	X			
Z8F4822				X	X	
Z8F4823						X
Z8F6421	X	X	X			
Z8F6422				X	X	
Z8F6423						X

Pin Configurations

Figure 2 through Figure 7 on page 13 display the pin configurations for all of the packages available in the Z8 Encore! XP 64K Series Flash Microcontrollers. For description of the signals, see Table 3 on page 14. Timer 3 is not available in the 40-pin and 44-pin packages.

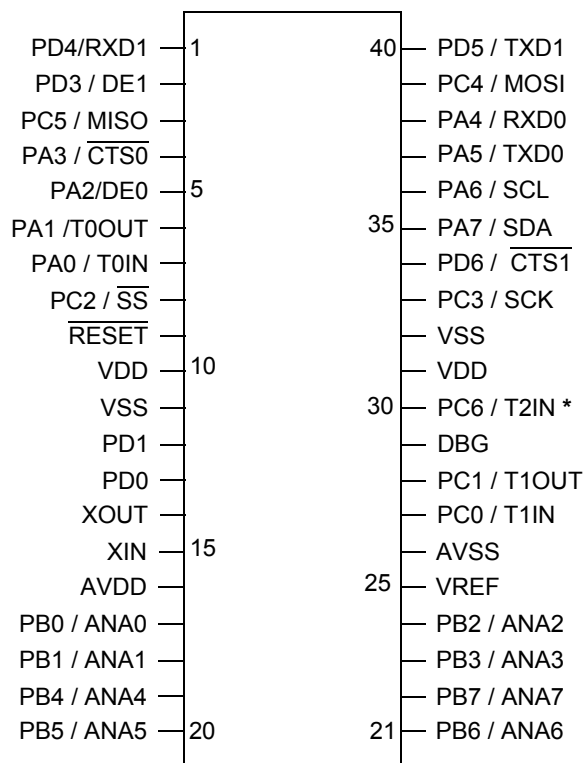

Note: Timer 3 is not supported.

* T2OUT is not supported.

Figure 2. Z8 Encore! XP 64K Series Flash Microcontrollers in 40-Pin Dual Inline Package (PDIP)

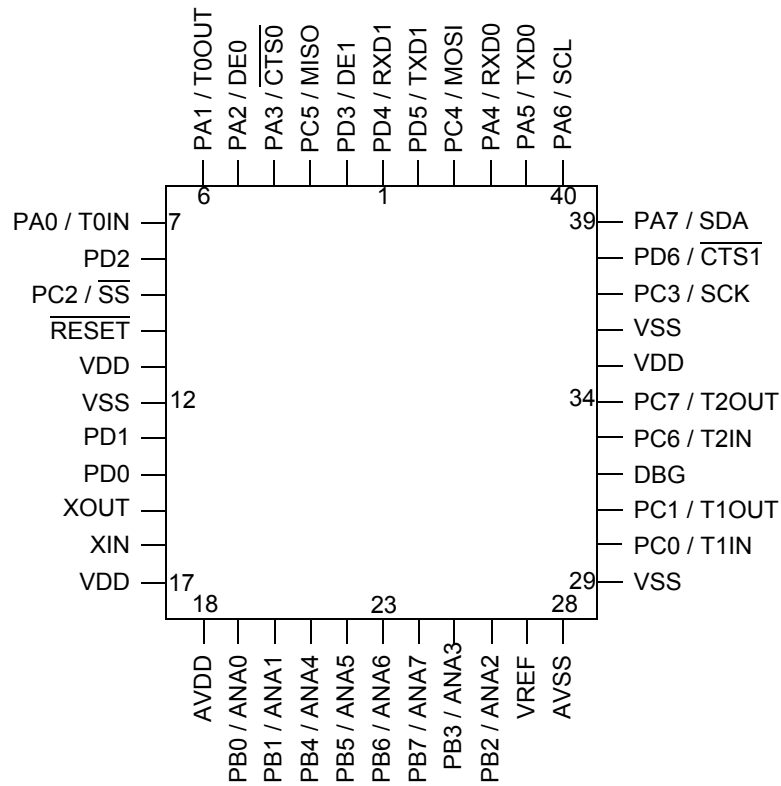

Figure 3. Z8 Encore! XP 64K Series Flash Microcontrollers in 44-Pin Plastic Leaded Chip Carrier (PLCC)

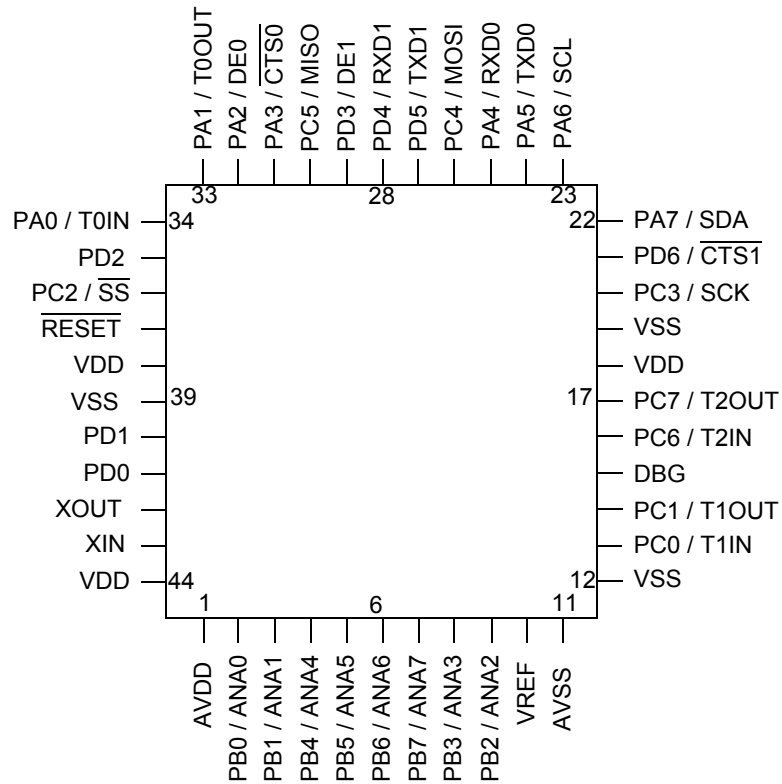

Figure 4. Z8 Encore! XP 64K Series Flash Microcontrollers in 44-Pin Low-Profile Quad Flat Package (LQFP)

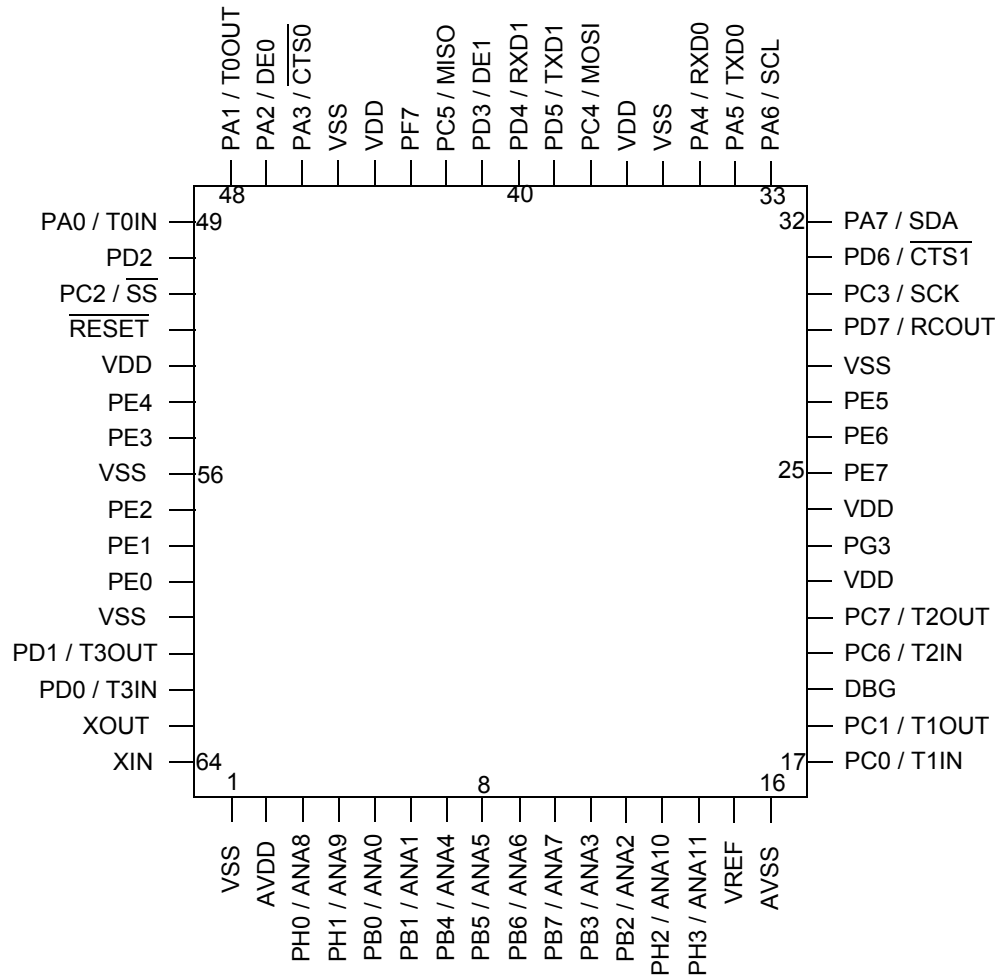

Figure 5. Z8 Encore! XP 64K Series Flash Microcontrollers in 64-Pin Low-Profile Quad Flat Package (LQFP)

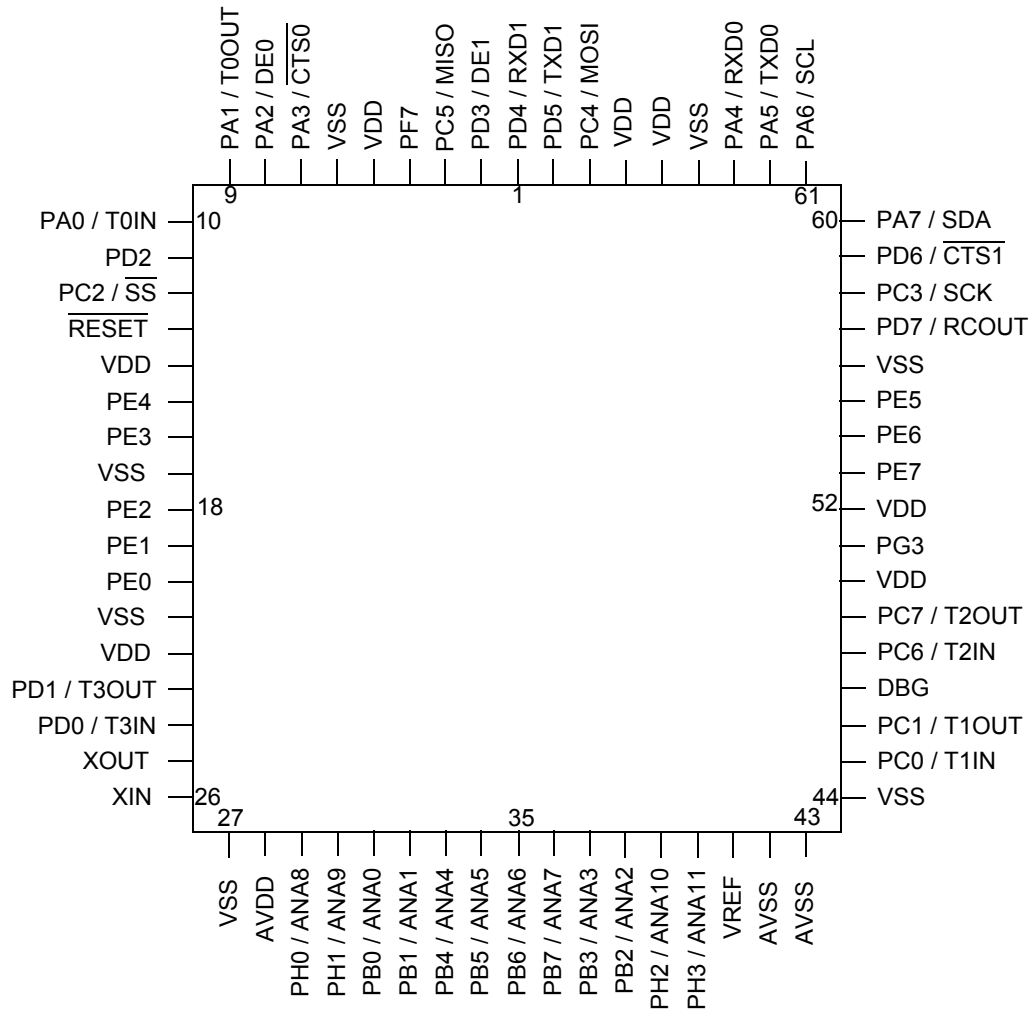

Figure 6. Z8 Encore! XP 64K Series Flash Microcontrollers in 68-Pin Plastic Leaded Chip Carrier (PLCC)

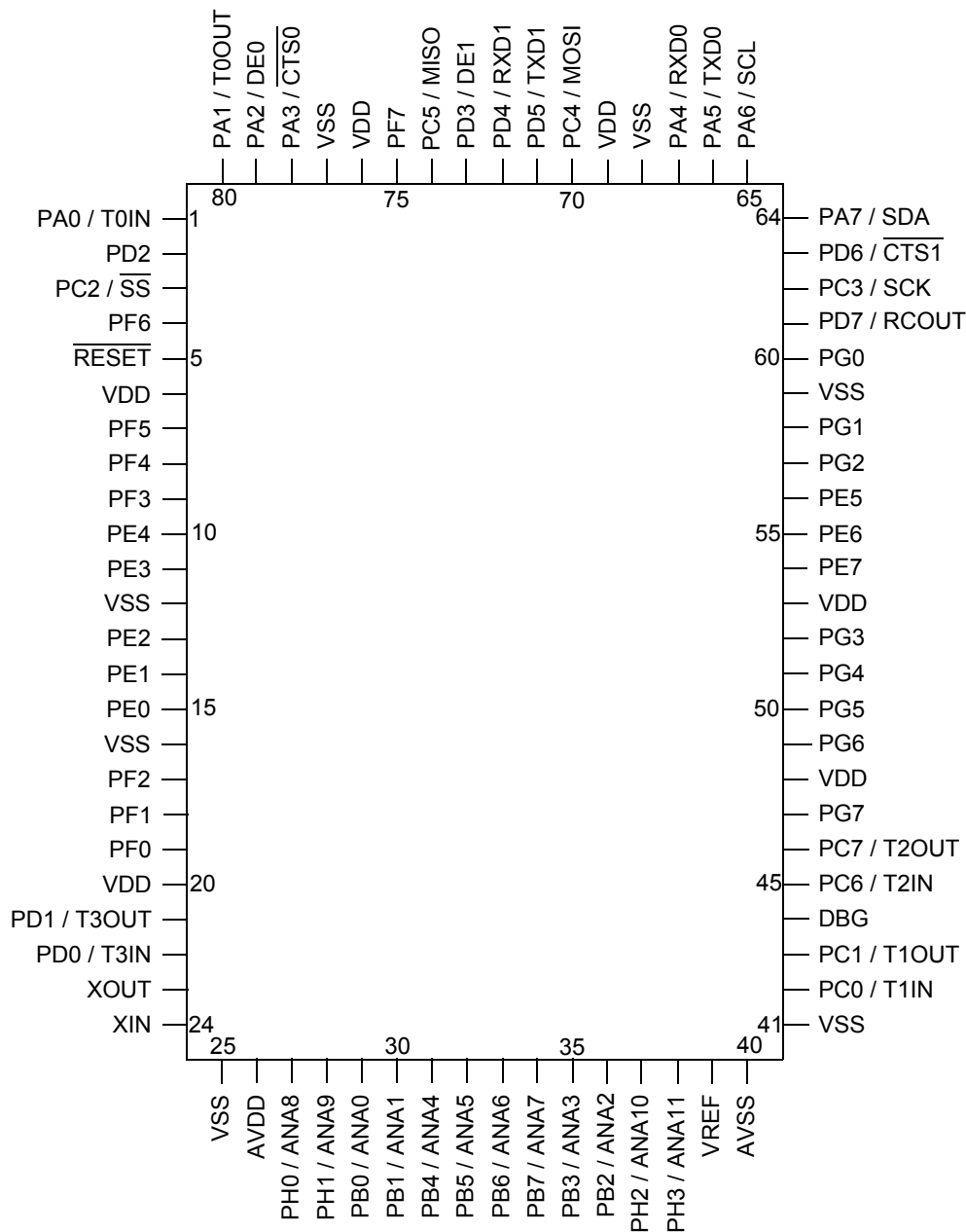

Figure 7. Z8 Encore! XP 64K Series Flash Microcontrollers in 80-Pin Quad Flat Package (QFP)

Signal Descriptions

Table 3 describes the Z8 Encore! XP signals. To determine the signals available for the specific package styles, see [Pin Configurations](#) on page 8.

Table 3. Signal Descriptions

Signal Mnemonic	I/O	Description
General-Purpose I/O Ports A-H		
PA[7:0]	I/O	Port A[7:0]. These pins are used for general-purpose I/O and support 5 V-tolerant inputs.
PB[7:0]	I/O	Port B[7:0]. These pins are used for general-purpose I/O.
PC[7:0]	I/O	Port C[7:0]. These pins are used for general-purpose I/O. These pins are used for general-purpose I/O and support 5 V-tolerant inputs
PD[7:0]	I/O	Port D[7:0]. These pins are used for general-purpose I/O. These pins are used for general-purpose I/O and support 5 V-tolerant inputs
PE[7:0]	I/O	Port E[7:0]. These pins are used for general-purpose I/O. These pins are used for general-purpose I/O and support 5 V-tolerant inputs.
PF[7:0]	I/O	Port F[7:0]. These pins are used for general-purpose I/O. These pins are used for general-purpose I/O and support 5 V-tolerant inputs.
PG[7:0]	I/O	Port G[7:0]. These pins are used for general-purpose I/O. These pins are used for general-purpose I/O and support 5 V-tolerant inputs.
PH[3:0]	I/O	Port H[3:0]. These pins are used for general-purpose I/O.
I²C Controller		
SCL	O	Serial Clock. This is the output clock for the I ² C. This pin is multiplexed with a general-purpose I/O pin. When the general-purpose I/O pin is configured for alternate function to enable the SCL function, this pin is open-drain.
SDA	I/O	Serial Data. This open-drain pin transfers data between the I ² C and a slave. This pin is multiplexed with a general-purpose I/O pin. When the general-purpose I/O pin is configured for alternate function to enable the SDA function, this pin is open-drain.
SPI Controller		
SS	I/O	Slave Select. This signal can be an output or an input. If the Z8 Encore! XP 64K Series Flash Microcontrollers is the SPI master, this pin may be configured as the Slave Select output. If the Z8 Encore! XP 64K Series Flash Microcontrollers is the SPI slave, this pin is the input slave select. It is multiplexed with a general-purpose I/O pin.

Table 3. Signal Descriptions (Continued)

Signal Mnemonic	I/O	Description
SCK	I/O	SPI Serial Clock. The SPI master supplies this pin. If the Z8 Encore! XP 64K Series Flash Microcontrollers is the SPI master, this pin is an output. If the Z8 Encore! XP 64K Series Flash Microcontrollers is the SPI slave, this pin is an input. It is multiplexed with a general-purpose I/O pin.
MOSI	I/O	Master-Out/Slave-In. This signal is the data output from the SPI master device and the data input to the SPI slave device. It is multiplexed with a general-purpose I/O pin.
MISO	I/O	Master-In/Slave-Out. This pin is the data input to the SPI master device and the data output from the SPI slave device. It is multiplexed with a general-purpose I/O pin.
UART Controllers		
TXD0 / TXD1	O	Transmit Data. These signals are the transmit outputs from the UARTs. The TXD signals are multiplexed with general-purpose I/O pins.
RXD0 / RXD1	I	Receive Data. These signals are the receiver inputs for the UARTs and IrDAs. The RXD signals are multiplexed with general-purpose I/O pins.
$\overline{\text{CTS0}}$ / $\overline{\text{CTS1}}$	I	Clear To Send. These signals are control inputs for the UARTs. The $\overline{\text{CTS}}$ signals are multiplexed with general-purpose I/O pins.
DE0 / DE1	O	Driver Enable. This signal allows automatic control of external RS-485 drivers. This signal is approximately the inverse of the Transmit Empty (TXE) bit in the UART Status 0 register. The DE signal may be used to ensure an external RS-485 driver is enabled when data is transmitted by the UART.
Timers		
T0OUT/T1OUT/ T2OUT/T3OUT	O	Timer Output 0-3. These signals are output pins from the timers. The Timer Output signals are multiplexed with general-purpose I/O pins. T3OUT is not available in 44-pin package devices.
T0IN/T1IN/ T2IN/T3IN	I	Timer Input 0-3. These signals are used as the capture, gating and counter inputs. The Timer Input signals are multiplexed with general-purpose I/O pins. T3IN is not available in 44-pin package devices.
Analog		
ANA[11:0]	I	Analog Input. These signals are inputs to the ADC. The ADC analog inputs are multiplexed with general-purpose I/O pins.
VREF	I	Analog-to-Digital converter reference voltage input. The VREF pin must be left unconnected (or capacitively coupled to analog ground) if the internal voltage reference is selected as the ADC reference voltage.
Oscillators		

Table 3. Signal Descriptions (Continued)

Signal Mnemonic	I/O	Description
XIN	I	External Crystal Input. This is the input pin to the crystal oscillator. A crystal can be connected between it and the XOUT pin to form the oscillator. This signal is usable with external RC networks and an external clock driver.
XOUT	O	External Crystal Output. This pin is the output of the crystal oscillator. A crystal can be connected between it and the XIN pin to form the oscillator. When the system clock is referred to in this manual, it refers to the frequency of the signal at this pin. This pin must be left unconnected when not using a crystal.
RCOUT	O	RC Oscillator Output. This signal is the output of the RC oscillator. It is multiplexed with a general-purpose I/O pin. This signal must be left unconnected when not using a crystal.
On-Chip Debugger		
DBG	I/O	Debug. This pin is the control and data input and output to and from the On-Chip Debugger. This pin is open-drain.
 Caution: <i>For operation of the On-Chip Debugger, all power pins (V_{DD} and AV_{DD}) must be supplied with power and all ground pins (V_{SS} and AV_{SS}) must be properly grounded.</i>		
<p><i>The DBG pin is open-drain and must have an external pull-up resistor to ensure proper operation.</i></p>		
Reset		
RESET	I	RESET. Generates a Reset when asserted (driven Low).
Power Supply		
VDD	I	Power Supply.
AVDD	I	Analog Power Supply.
VSS	I	Ground.
AVSS	I	Analog Ground.

Pin Characteristics

Table 4 on page 17 provides detailed information on the characteristics for each pin available on the 64K Series products and the data is sorted alphabetically by the pin symbol mnemonic.

Table 4. Pin Characteristics of the Z8 Encore! XP 64K Series Flash Microcontrollers

Symbol Mnemonic	Direction	Reset Direction	Active Low or Active High	Tri-State Output	Internal Pull-up or Pull-down	Schmitt-Trigger Input	Open Drain Output
AVSS	N/A	N/A	N/A	N/A	No	No	N/A
AVDD	N/A	N/A	N/A	N/A	No	No	N/A
DBG	I/O	I	N/A	Yes	No	Yes	Yes
VSS	N/A	N/A	N/A	N/A	No	No	N/A
PA[7:0]	I/O	I	N/A	Yes	No	Yes	Yes, Programmable
PB[7:0]	I/O	I	N/A	Yes	No	Yes	Yes, Programmable
PC[7:0]	I/O	I	N/A	Yes	No	Yes	Yes, Programmable
PD[7:0]	I/O	I	N/A	Yes	No	Yes	Yes, Programmable
PE[7:0]	I/O	I	N/A	Yes	No	Yes	Yes, Programmable
PF[7:0]	I/O	I	N/A	Yes	No	Yes	Yes, Programmable
PG[7:0]	I/O	I	N/A	Yes	No	Yes	Yes, Programmable
PH[3:0]	I/O	I	N/A	Yes	No	Yes	Yes, Programmable
RESET	I	I	Low	N/A	Pull-up	Yes	N/A
VDD	N/A	N/A	N/A	N/A	No	No	N/A
XIN	I	I	N/A	N/A	No	No	N/A
XOUT	O	O	N/A	Yes, in STOP mode	No	No	No

Note: x represents integer 0, 1,... to indicate multiple pins with symbol mnemonics that differ only by the integer.



Address Space

Overview

The eZ8[™] CPU can access three distinct address spaces:

- The Register File contains addresses for the general-purpose registers and the eZ8 CPU, peripheral, and general-purpose I/O port control registers.
- The Program Memory contains addresses for all memory locations having executable code and/or data.
- The Data Memory consists of the addresses for all memory locations that hold only data.

These three address spaces are covered briefly in the following subsections. For more information on eZ8 CPU and its address space, refer to *eZ8[™] CPU Core User Manual (UM0128)* available for download at www.zilog.com.

Register File

The Register File address space in the 64K Series is 4 KB (4096 bytes). The Register File is composed of two sections—control registers and general-purpose registers. When instructions are executed, registers are read from when defined as sources and written to when defined as destinations. The architecture of the eZ8 CPU allows all general-purpose registers to function as accumulators, address pointers, index registers, stack areas, or scratch pad memory.

The upper 256 bytes of the 4 KB Register File address space are reserved for control of the eZ8 CPU, the on-chip peripherals, and the I/O ports. These registers are located at addresses from F00H to FFFH. Some of the addresses within the 256-byte control register section are reserved (unavailable). Reading from an reserved Register File addresses returns an undefined value. Writing to reserved Register File addresses is not recommended and can produce unpredictable results.

The on-chip RAM always begins at address 000H in the Register File address space. The 64K Series provide 2 KB to 4 KB of on-chip RAM depending upon the device. Reading from Register File addresses outside the available RAM addresses (and not within the control register address space) returns an undefined value. Writing to these Register File addresses produces no effect. To determine the amount of RAM available for the specific 64K Series device, see [Part Selection Guide](#) on page 2.

Program Memory

The eZ8[™] CPU supports 64 KB of Program Memory address space. The Z8 Encore! XP 64K Series Flash Microcontrollers contains 16 KB to 64 KB of on-chip Flash in the Program Memory address space, depending upon the device. Reading from Program Memory addresses outside the available Flash memory addresses returns FFH. Writing to these unimplemented Program Memory addresses produces no effect. [Table 5](#) describes the Program Memory maps for the 64K Series products.

Table 5. Z8 Encore! XP 64K Series Flash Microcontrollers Program Memory Maps

Program Memory Address (Hex)	Function
Z8F162x Products	
0000-0001	Option Bits
0002-0003	Reset Vector
0004-0005	WDT Interrupt Vector
0006-0007	Illegal Instruction Trap
0008-0037	Interrupt Vectors*
0038-3FFF	Program Memory
Z8F242x Products	
0000-0001	Option Bits
0002-0003	Reset Vector
0004-0005	WDT Interrupt Vector
0006-0007	Illegal Instruction Trap
0008-0037	Interrupt Vectors*
0038-5FFF	Program Memory
Z8F322x Products	
0000-0001	Option Bits
0002-0003	Reset Vector
0004-0005	WDT Interrupt Vector
0006-0007	Illegal Instruction Trap
0008-0037	Interrupt Vectors*
0038-7FFF	Program Memory
Z8F482x Products	

Table 5. Z8 Encore! XP 64K Series Flash Microcontrollers Program Memory Maps (Continued)

Program Memory Address (Hex)	Function
0000-0001	Option Bits
0002-0003	Reset Vector
0004-0005	WDT Interrupt Vector
0006-0007	Illegal Instruction Trap
0008-0037	Interrupt Vectors*
0038-BFFF	Program Memory
Z8F642x Products	
0000-0001	Option Bits
0002-0003	Reset Vector
0004-0005	WDT Interrupt Vector
0006-0007	Illegal Instruction Trap
0008-0037	Interrupt Vectors*
0038-FFFF	Program Memory

*See [Table 23](#) on page 68 for a list of the interrupt vectors.

Data Memory

The Z8 Encore! XP 64K Series Flash Microcontrollers does not use the eZ8 CPU's 64 KB Data Memory address space.

Information Area

[Table 6](#) on page 22 describes the Z8 Encore! XP 64K Series Flash Microcontrollers Information Area. This 512 byte Information Area is accessed by setting bit 7 of the Page Select Register to 1. When access is enabled, the Information Area is mapped into the Program Memory and overlays the 512 bytes at addresses FE00H to FFFFH. When the Information Area access is enabled, execution of LDC and LDCI instruction from these Program Memory addresses return the Information Area data rather than the Program Memory data. Reads of these addresses through the On-Chip Debugger also returns the Information Area data. Execution of code from these addresses continues to correctly use the Program Memory. Access to the Information Area is read-only.

Table 6. Z8 Encore! XP 64K Series Flash Microcontrollers Information Area Map

Program Memory Address (Hex)	Function
FE00H-FE3FH	Reserved
FE40H-FE53H	Part Number 20-character ASCII alphanumeric code Left justified and filled with zeros (ASCII Null character)
FE54H-FFFFH	Reserved



Register File Address Map

Table 7 provides the address map for the Register File of the 64K Series products. Not all devices and package styles in the 64K Series support Timer 3 and all of the GPIO Ports. Consider registers for unimplemented peripherals as Reserved.

Table 7. Z8 Encore! XP 64K Series Flash Microcontrollers Register File Address Map

Address (Hex)	Register Description	Mnemonic	Reset (Hex)	Page No
General-Purpose RAM				
000-EFF	General-Purpose Register File RAM	—	XX	
Timer 0				
F00	Timer 0 High Byte	T0H	00	90
F01	Timer 0 Low Byte	T0L	01	90
F02	Timer 0 Reload High Byte	T0RH	FF	91
F03	Timer 0 Reload Low Byte	T0RL	FF	91
F04	Timer 0 PWM High Byte	T0PWMH	00	92
F05	Timer 0 PWM Low Byte	T0PWML	00	92
F06	Timer 0 Control 0	T0CTL0	00	93
F07	Timer 0 Control 1	T0CTL1	00	94
Timer 1				
F08	Timer 1 High Byte	T1H	00	90
F09	Timer 1 Low Byte	T1L	01	90
F0A	Timer 1 Reload High Byte	T1RH	FF	91
F0B	Timer 1 Reload Low Byte	T1RL	FF	91
F0C	Timer 1 PWM High Byte	T1PWMH	00	92
F0D	Timer 1 PWM Low Byte	T1PWML	00	92
F0E	Timer 1 Control 0	T1CTL0	00	93
F0F	Timer 1 Control 1	T1CTL1	00	94
Timer 2				
F10	Timer 2 High Byte	T2H	00	90
F11	Timer 2 Low Byte	T2L	01	90
F12	Timer 2 Reload High Byte	T2RH	FF	91
F13	Timer 2 Reload Low Byte	T2RL	FF	91
F14	Timer 2 PWM High Byte	T2PWMH	00	92
F15	Timer 2 PWM Low Byte	T2PWML	00	92
F16	Timer 2 Control 0	T2CTL0	00	93
F17	Timer 2 Control 1	T2CTL1	00	94

Table 7. Z8 Encore! XP 64K Series Flash Microcontrollers Register File Address Map (Continued)

Address (Hex)	Register Description	Mnemonic	Reset (Hex)	Page No
Timer 3 (unavailable in the 44-pin packages)				
F18	Timer 3 High Byte	T3H	00	90
F19	Timer 3 Low Byte	T3L	01	90
F1A	Timer 3 Reload High Byte	T3RH	FF	91
F1B	Timer 3 Reload Low Byte	T3RL	FF	91
F1C	Timer 3 PWM High Byte	T3PWMH	00	92
F1D	Timer 3 PWM Low Byte	T3PWML	00	92
F1E	Timer 3 Control 0	T3CTL0	00	93
F1F	Timer 3 Control 1	T3CTL1	00	94
20-3F	Reserved	—	XX	
UART 0				
F40	UART0 Transmit Data	U0TXD	XX	114
	UART0 Receive Data	U0RXD	XX	115
F41	UART0 Status 0	U0STAT0	0000011Xb	115
F42	UART0 Control 0	U0CTL0	00	117
F43	UART0 Control 1	U0CTL1	00	117
F44	UART0 Status 1	U0STAT1	00	115
F45	UART0 Address Compare Register	U0ADDR	00	120
F46	UART0 Baud Rate High Byte	U0BRH	FF	120
F47	UART0 Baud Rate Low Byte	U0BRL	FF	120
UART 1				
F48	UART1 Transmit Data	U1TXD	XX	114
	UART1 Receive Data	U1RXD	XX	115
F49	UART1 Status 0	U1STAT0	0000011Xb	115
F4A	UART1 Control 0	U1CTL0	00	117
F4B	UART1 Control 1	U1CTL1	00	117
F4C	UART1 Status 1	U1STAT1	00	115
F4D	UART1 Address Compare Register	U1ADDR	00	120
F4E	UART1 Baud Rate High Byte	U1BRH	FF	120
F4F	UART1 Baud Rate Low Byte	U1BRL	FF	120
I²C				
F50	I ² C Data	I2CDATA	00	156
F51	I ² C Status	I2CSTAT	80	157
F52	I ² C Control	I2CCTL	00	158
F53	I ² C Baud Rate High Byte	I2CBRH	FF	160
F54	I ² C Baud Rate Low Byte	I2CBRL	FF	160
F55	I ² C Diagnostic State	I2CDST	C0	161
F56	I ² C Diagnostic Control	I2CDIAG	00	163
F57-F5F	Reserved	—	XX	
Serial Peripheral Interface (SPI)				
F60	SPI Data	SPIDATA	XX	137

Table 7. Z8 Encore! XP 64K Series Flash Microcontrollers Register File Address Map (Continued)

Address (Hex)	Register Description	Mnemonic	Reset (Hex)	Page No
F61	SPI Control	SPICTL	00	137
F62	SPI Status	SPISTAT	01	139
F63	SPI Mode	SPIMODE	00	140
F64	SPI Diagnostic State	SPIDST	00	141
F65	Reserved	—	XX	
F66	SPI Baud Rate High Byte	SPIBRH	FF	142
F67	SPI Baud Rate Low Byte	SPIBRL	FF	142
F68-F6F	Reserved	—	XX	
Analog-to-Digital Converter				
F70	ADC Control	ADCCTL	20	179
F71	Reserved	—	XX	
F72	ADC Data High Byte	ADCD_H	XX	180
F73	ADC Data Low Bits	ADCD_L	XX	180
F74-FAF	Reserved	—	XX	
DMA 0				
FB0	DMA0 Control	DMA0CTL	00	167
FB1	DMA0 I/O Address	DMA0IO	XX	169
FB2	DMA0 End/Start Address High Nibble	DMA0H	XX	169
FB3	DMA0 Start Address Low Byte	DMA0START	XX	170
FB4	DMA0 End Address Low Byte	DMA0END	XX	170
DMA 1				
FB8	DMA1 Control	DMA1CTL	00	167
FB9	DMA1 I/O Address	DMA1IO	XX	169
FBA	DMA1 End/Start Address High Nibble	DMA1H	XX	169
FBB	DMA1 Start Address Low Byte	DMA1START	XX	170
FBC	DMA1 End Address Low Byte	DMA1END	XX	170
DMA ADC				
FBD	DMA_ADC Address	DMAA_ADDR	XX	171
FBE	DMA_ADC Control	DMAACTL	00	172
FBF	DMA_ADC Status	DMAASTAT	00	173
Interrupt Controller				
FC0	Interrupt Request 0	IRQ0	00	71
FC1	IRQ0 Enable High Bit	IRQ0ENH	00	74
FC2	IRQ0 Enable Low Bit	IRQ0ENL	00	74
FC3	Interrupt Request 1	IRQ1	00	72
FC4	IRQ1 Enable High Bit	IRQ1ENH	00	75
FC5	IRQ1 Enable Low Bit	IRQ1ENL	00	75
FC6	Interrupt Request 2	IRQ2	00	73
FC7	IRQ2 Enable High Bit	IRQ2ENH	00	76
FC8	IRQ2 Enable Low Bit	IRQ2ENL	00	76
FC9-FCC	Reserved	—	XX	



Table 7. Z8 Encore! XP 64K Series Flash Microcontrollers Register File Address Map (Continued)

Address (Hex)	Register Description	Mnemonic	Reset (Hex)	Page No
FCD	Interrupt Edge Select	IRQES	00	78
FCE	Interrupt Port Select	IRQPS	00	78
FCF	Interrupt Control	IRQCTL	00	79
GPIO Port A				
FD0	Port A Address	PAADDR	00	61
FD1	Port A Control	PACTL	00	62
FD2	Port A Input Data	PAIN	XX	66
FD3	Port A Output Data	PAOUT	00	66
GPIO Port B				
FD4	Port B Address	PBADDR	00	61
FD5	Port B Control	PBCTL	00	62
FD6	Port B Input Data	PBIN	XX	66
FD7	Port B Output Data	PBOUT	00	66
GPIO Port C				
FD8	Port C Address	PCADDR	00	61
FD9	Port C Control	PCCTL	00	62
FDA	Port C Input Data	PCIN	XX	66
FDB	Port C Output Data	PCOUT	00	66
GPIO Port D				
FDC	Port D Address	PDADDR	00	61
FDD	Port D Control	PDCTL	00	62
FDE	Port D Input Data	PDIN	XX	66
FDF	Port D Output Data	PDOUT	00	66
GPIO Port E				
FE0	Port E Address	PEADDR	00	61
FE1	Port E Control	PECTL	00	62
FE2	Port E Input Data	PEIN	XX	66
FE3	Port E Output Data	PEOUT	00	66
GPIO Port F				
FE4	Port F Address	PFADDR	00	61
FE5	Port F Control	PFCTL	00	62
FE6	Port F Input Data	PFIN	XX	66
FE7	Port F Output Data	PFOUT	00	66
GPIO Port G				
FE8	Port G Address	PGADDR	00	61
FE9	Port G Control	PGCTL	00	62
FEA	Port G Input Data	PGIN	XX	66
FEB	Port G Output Data	PGOUT	00	66
GPIO Port H				
FEC	Port H Address	PHADDR	00	61
FED	Port H Control	PHCTL	00	62
FEE	Port H Input Data	PHIN	XX	66



Table 7. Z8 Encore! XP 64K Series Flash Microcontrollers Register File Address Map (Continued)

Address (Hex)	Register Description	Mnemonic	Reset (Hex)	Page No
FEF	Port H Output Data	PHOUT	00	66
Watchdog Timer				
FF0	Watchdog Timer Control	WDTCTL	XXX00000b	100
FF1	Watchdog Timer Reload Upper Byte	WDTU	FF	101
FF2	Watchdog Timer Reload High Byte	WDTH	FF	101
FF3	Watchdog Timer Reload Low Byte	WDTL	FF	101
FF4-FF7	Reserved	—	XX	
Flash Memory Controller				
FF8	Flash Control	FCTL	00	190
FF8	Flash Status	FSTAT	00	190
FF9	Page Select	FPS	00	191
FF9 (if enabled)	Flash Sector Protect	FPROT	00	192
FFA	Flash Programming Frequency High Byte	FFREQH	00	192
FFB	Flash Programming Frequency Low Byte	FFREQL	00	192
FF4-FF8	Reserved	—	XX	
Read-Only Memory Controller				
FF9	Page Select	RPS	00	
FFA-FFB	Reserved	—	XX	
eZ8 CPU				
FFC	Flags	—	XX	Refer to eZ8 [™] CPU Core User Manual (UM0128)
FFD	Register Pointer	RP	XX	
FFE	Stack Pointer High Byte	SPH	XX	
FFF	Stack Pointer Low Byte	SPL	XX	
Note: XX=Undefined				

Control Register Summary

Timer 0 High Byte

T0H (F00H - Read/Write)

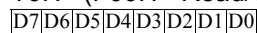

Timer 0 current count value [15:8]

Timer 0 Low Byte

T0L (F01H - Read/Write)

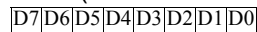

Timer 0 current count value [7:0]

Timer 0 Reload High Byte

T0RH (F02H - Read/Write)

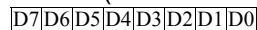

Timer 0 reload value [15:8]

Timer 0 Reload Low Byte

T0RL (HF03 - Read/Write)

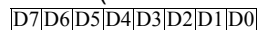

Timer 0 reload value [7:0]

Timer 0 PWM High Byte

T0PWMH (F04H - Read/Write)

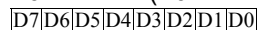

Timer 0 PWM value [15:8]

Timer 0 Control 0

T0CTL0 (F06H - Read/Write)

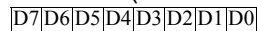

Reserved
 Cascade Timer
 0 = Timer 0 Input signal is GPIO pin
 1 = Timer 0 Input signal is Timer 3
 out
 Reserved

Timer 0 Control 1

T0CTL1 (F07H - Read/Write)

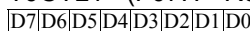

Timer Mode
 000 = One-Shot mode
 001 = CONTINUOUS mode
 010 = COUNTER mode
 011 = PWM mode
 100 = CAPTURE mode
 101 = COMPARE mode
 110 = GATED mode
 111 = Capture/COMPARE mode

Prescale Value
 000 = Divide by 1
 001 = Divide by 2
 010 = Divide by 4
 011 = Divide by 8
 100 = Divide by 16
 101 = Divide by 32
 110 = Divide by 64
 111 = Divide by 128

Timer Input/Output Polarity
 Operation of this bit is a function of the current operating mode of the timer

Timer Enable
 0 = Timer is disabled
 1 = Timer is enabled

Timer 1 High Byte

T1H (F08H - Read/Write)

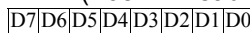

Timer 1 current count value [15:8]

Timer 1 Low Byte

T1L (F09H - Read/Write)

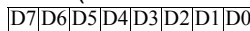

Timer 1 current count value [7:0]

Timer 1 Reload High Byte

T1RH (F0AH - Read/Write)

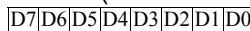

Timer 1 reload value [15:8]

Timer 1 Reload Low Byte

T1RL (F0BH - Read/Write)

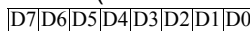

Timer 1 reload value [7:0]



Timer 1 PWM High Byte

T1PWMH (F0CH - Read/Write)

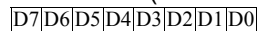

Timer 1 PWM value [15:8]

Timer 2 High Byte

T2H (F10H - Read/Write)

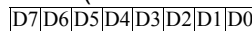

Timer 2 current count value [15:8]

Timer 1 PWM Low Byte

T1PWML (F0DH - Read/Write)

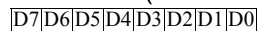

Timer 1 PWM value [7:0]

Timer 2 Low Byte

T2L (F11H - Read/Write)

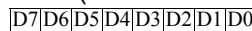

Timer 2 current count value [7:0]

Timer 1 Control 0

T1CTL0 (F0EH - Read/Write)

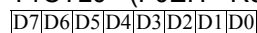

- Reserved
- Cascade Timer
0 = Timer 1 Input signal is GPIO pin
1 = Timer 1 Input signal is Timer 0 out
- Reserved

Timer 2 Reload High Byte

T2RH (F12H - Read/Write)

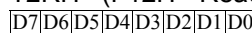

Timer 2 reload value [15:8]

Timer 2 Reload Low Byte

T2RL (F13H - Read/Write)

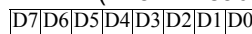

Timer 2 reload value [7:0]

Timer 1 Control 1

T1CTL1 (F0FH - Read/Write)

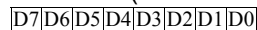

- Timer Mode
000 = One-Shot mode
001 = CONTINUOUS mode
010 = COUNTER mode
011 = PWM mode
100 = CAPTURE mode
101 = COMPARE mode
110 = GATED mode
111 = Capture/COMPARE mode
- Prescale Value
000 = Divide by 1
001 = Divide by 2
010 = Divide by 4
011 = Divide by 8
100 = Divide by 16
101 = Divide by 32
110 = Divide by 64
111 = Divide by 128
- Timer Input/Output Polarity
Operation of this bit is a function of the current operating mode of the timer
- Timer Enable
0 = Timer is disabled
1 = Timer is enabled

Timer 2 PWM High Byte

T2PWMH (F14H - Read/Write)

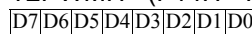

Timer 2 PWM value [15:8]

Timer 2 PWM Low Byte

T2PWML (F15H - Read/Write)

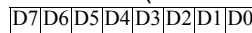

Timer 2 PWM value [7:0]

Timer 2 Control 0

T2CTL0 (F16H - Read/Write)

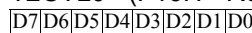

- Reserved
- Cascade Timer
0 = Timer 2 Input signal is GPIO pin
1 = Timer 2 Input signal is Timer 1 out
- Reserved

Timer 2 Control 1

T2CTL1 (F17H - Read/Write)

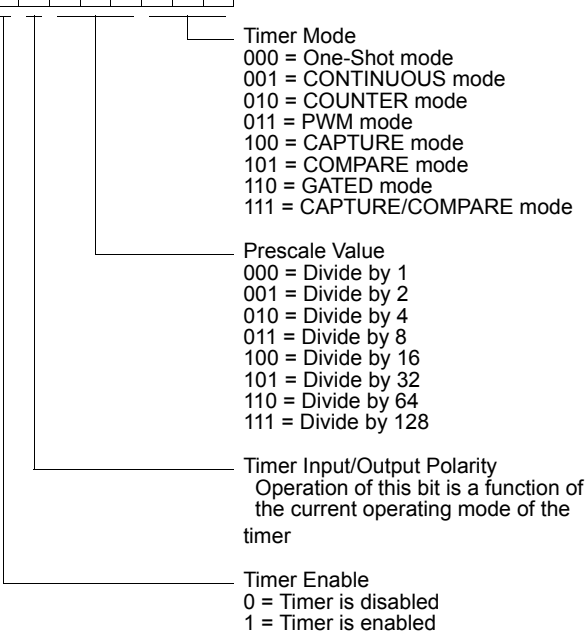
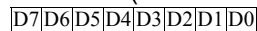

Timer 3 PWM High Byte

T3PWMH (F1CH - Read/Write)

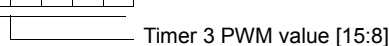
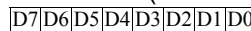

Timer 3 PWM Low Byte

T3PWML (F1DH - Read/Write)

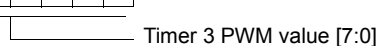
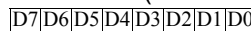

Timer 3 Control 0

T3CTL0 (F1EH - Read/Write)

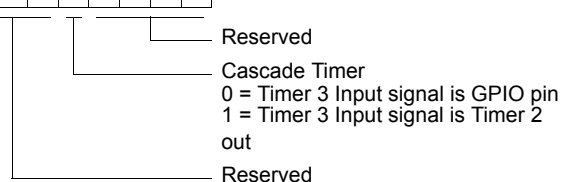
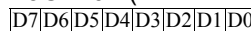

Timer 3 High Byte

T3H (F18H - Read/Write)

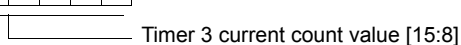
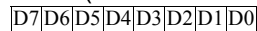

Timer 3 Low Byte

T3L (F19H - Read/Write)

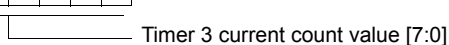
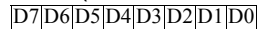

Timer 3 Reload High Byte

T3RH (F1AH - Read/Write)

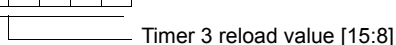
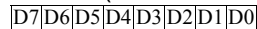

Timer 3 Reload Low Byte

T3RL (F1BH - Read/Write)

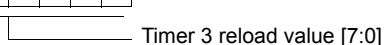
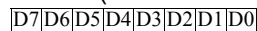

Timer 3 Control 1

T3CTL1 (F1FH - Read/Write)

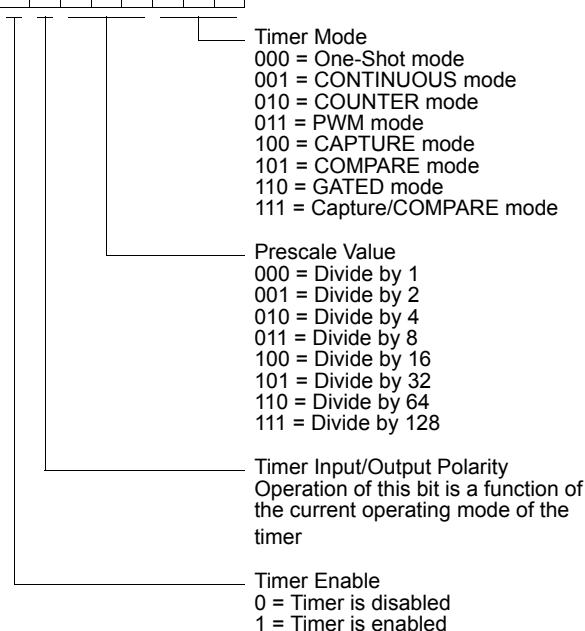
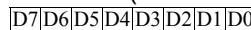



UART0 Transmit Data

U0TXD (F40H - Write Only)

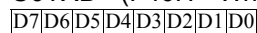

UART0 transmitter data byte [7:0]

UART0 Receive Data

U0RXD (F40H - Read Only)

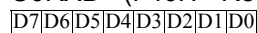

UART0 receiver data byte [7:0]

UART0 Status 0

U0STAT0 (F41H - Read Only)

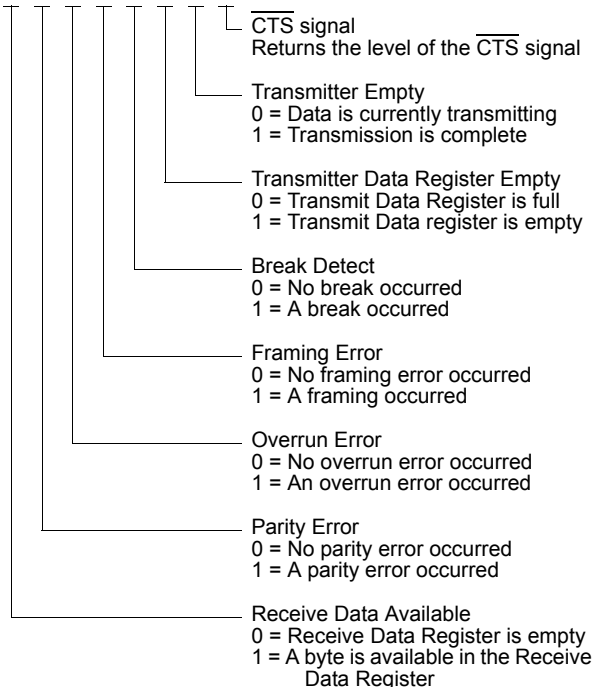
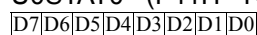

UART0 Control 0

U0CTL0 (F42H - Read/Write)

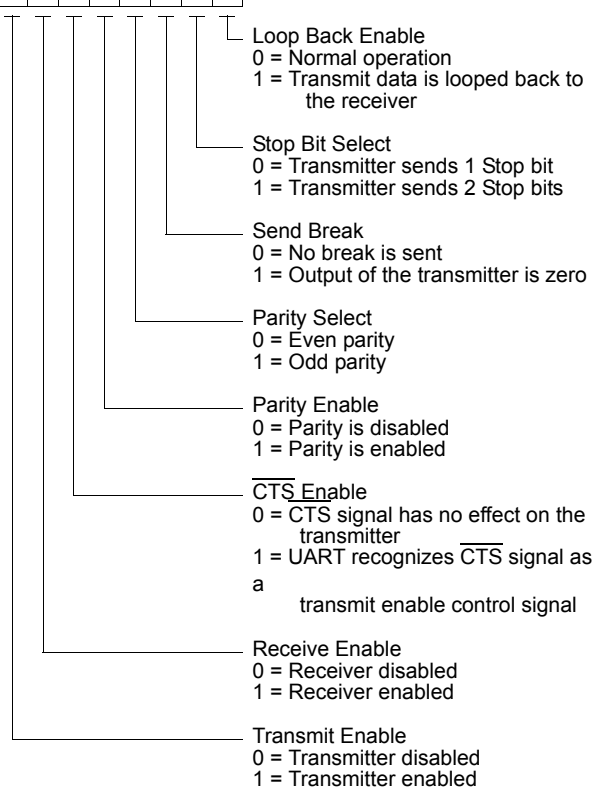
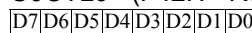



UART0 Control 1

U0CTL1 (F43H - Read/Write)

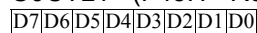

- D7: Infrared Encoder/Decoder Enable
0 = Infrared endec is disabled
1 = Infrared endec is enabled
- D6: Received Data Interrupt Enable
0 = Received data and errors generate interrupt requests
1 = Only errors generate interrupt requests. Received data does not.
- D5: Baud Rate Registers Control
Refer to UART chapter for operation
- D4: Driver Enable Polarity
0 = DE signal is active High
1 = DE signal is active Low
- D3: Multiprocessor Bit Transmit
0 = Send a 0 as the multiprocessor bit
1 = Send a 1 as the multiprocessor bit
- D2: Multiprocessor Mode [0]
See Multiprocessor Mode [1] below
- D1: Multiprocessor (9-bit) Enable
0 = Multiprocessor mode is disabled
1 = Multiprocessor mode is enabled
- D0: Multiprocessor Mode [1]
with Multiprocess Mode bit 0:
00 = Interrupt on all received bytes
01 = Interrupt only on address bytes
10 = Interrupt on address match and following data
11 = Interrupt on data following an address match

UART0 Status 1

U0STAT1 (F44H - Read Only)

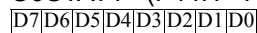

- D7: Reserved
- D6: Reserved
- D5: Reserved
- D4: Reserved
- D3: Reserved
- D2: Reserved
- D1: Reserved
- D0: Reserved

UART0 Address Compare

U0ADDR (F45H - Read/Write)



UART0 Address Compare [7:0]

UART0 Baud Rate Generator High Byte

U0BRH (F46H - Read/Write)

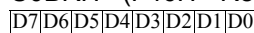

UART0 Baud Rate divisor [15:8]

UART0 Baud Rate Generator Low Byte

U0BRL (F47H - Read/Write)

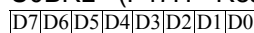

UART0 Baud Rate divisor [7:0]

UART1 Transmit Data

U1TXD (F48H - Write Only)

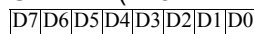

UART1 transmitter data byte[7:0]

UART1 Receive Data

U1RXD (F48H - Read Only)

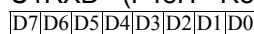

UART receiver data byte [7:0]



UART1 Status 0

U1STAT0 (F49H - Read Only)

D7 D6 D5 D4 D3 D2 D1 D0

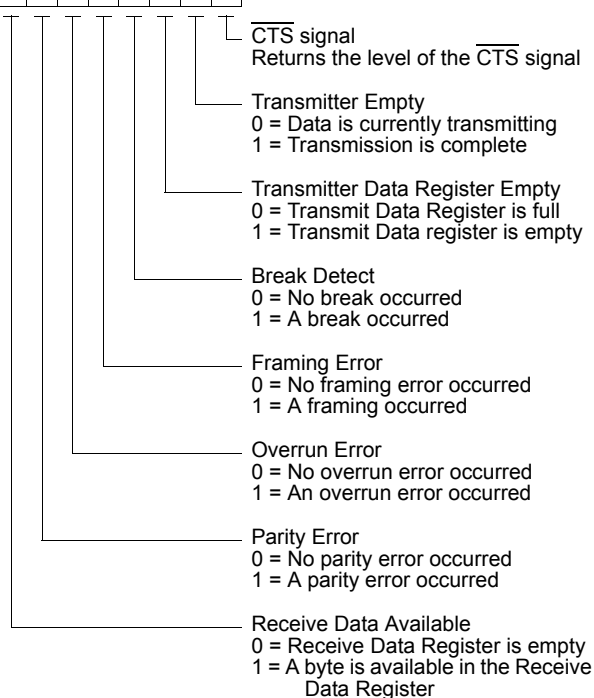

UART1 Control 0

U1CTL0 (F4AH - Read/Write)

D7 D6 D5 D4 D3 D2 D1 D0

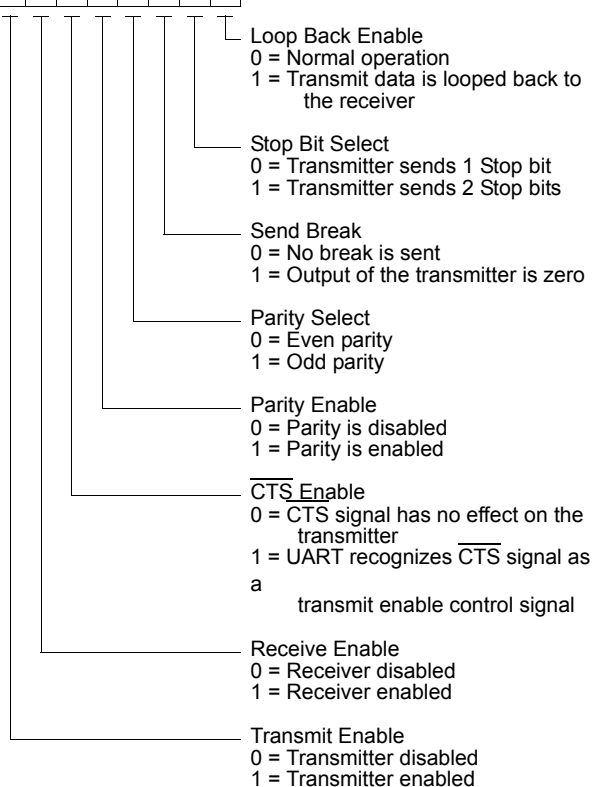

UART1 Control 1

U0CTL1 (F4BH - Read/Write)

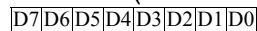

- D7: Infrared Encoder/Decoder Enable
0 = Infrared endec is disabled
1 = Infrared endec is enabled
- D6: Received Data Interrupt Enable
0 = Received data and errors generate interrupt requests
1 = Only errors generate interrupt requests. Received data does not.
- D5: Baud Rate Registers Control
Refer to UART chapter for operation
- D4: Driver Enable Polarity
0 = DE signal is active High
1 = DE signal is active Low
- D3: Multiprocessor Bit Transmit
0 = Send a 0 as the multiprocessor bit
1 = Send a 1 as the multiprocessor bit
- D2: Multiprocessor Mode [0]
See Multiprocessor Mode [1] below
- D1: Multiprocessor (9-bit) Enable
0 = Multiprocessor mode is disabled
1 = Multiprocessor mode is enabled
- D0: Multiprocessor Mode [1]
with Multiprocess Mode bit 0:
00 = Interrupt on all received bytes
01 = Interrupt only on address bytes
10 = Interrupt on address match and following data
11 = Interrupt on data following an address match

UART1 Address Compare

U0ADDR (F4DH - Read/Write)

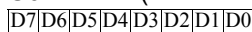

UART1 Address Compare [7:0]

UART1 Baud Rate Generator High Byte

U0BRH (F4EH - Read/Write)

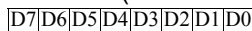

UART1 Baud Rate divisor [15:8]

UART1 Baud Rate Generator Low Byte

U1BRL (F4FH - Read/Write)

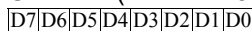

UART1 Baud Rate divisor [7:0]

I²C Data

I2CDATA (F50H - Read/Write)

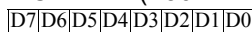

I2C data [7:0]

UART1 Status 1

U0STAT1 (F4CH - Read Only)

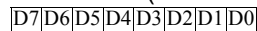

- D7: Multitprocessor Receive
Returns value of last multiprocessor bit
- D6: New Frame
0 = Current byte is not start of frame
1 = Current byte is start of new frame
- D5-D0: Reserved



I²C Status

I2CSTAT (F51H - Read Only)

D7 D6 D5 D4 D3 D2 D1 D0

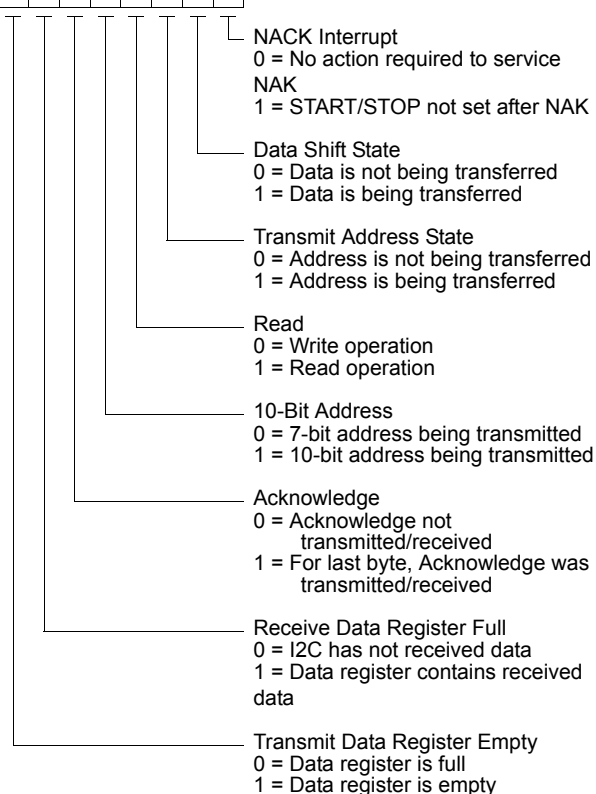

I²C Control

I2CCTL (F52H - Read/Write)

D7 D6 D5 D4 D3 D2 D1 D0

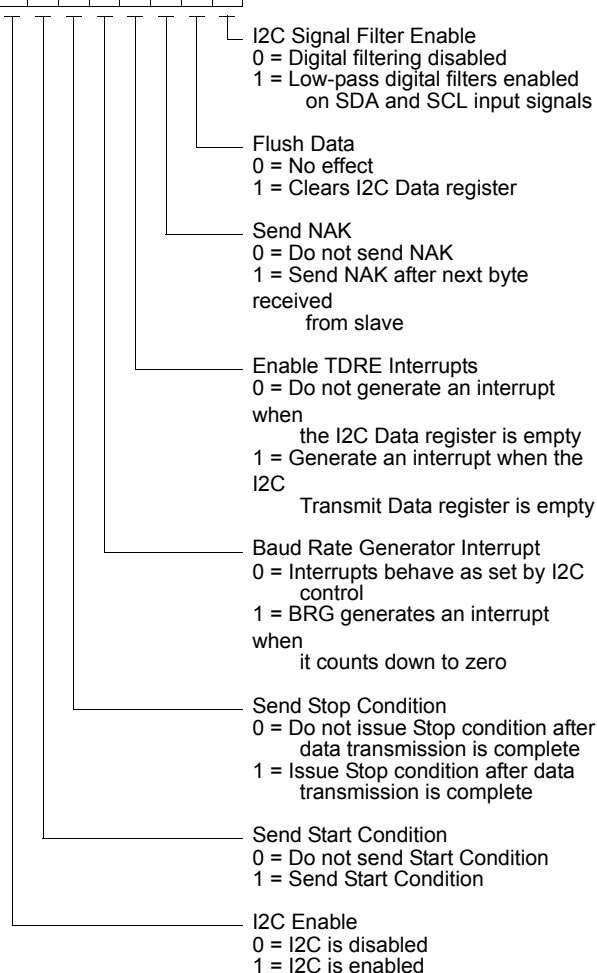

I2C Baud Rate Generator High Byte

I2CBRH (F53H - Read/Write)

D7 D6 D5 D4 D3 D2 D1 D0



I2C Baud Rate Generator Low Byte

I2CBRL (F54H - Read/Write)

D7 D6 D5 D4 D3 D2 D1 D0





SPI Data

SPIDATA (F60H - Read/Write)

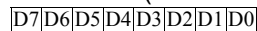

SPI Data [7:0]

SPI Control

SPICTL (F61H - Read/Write)

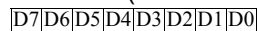

- SPI Enable
0 = SPI disabled
1 = SPI enabled
- Master Mode Enabled
0 = SPI configured in Slave mode
1 = SPI configured in Master mode
- Wire-OR (open-drain) Mode
0 = SPI signals not configured for open-drain
1 = SPI signals (SCK, \overline{SS} , MISO, and MOSI) configured for open-drain
- Clock Polarity
0 = SCK idles Low
1 = SPI idles High
- Phase Select
Sets the phase relationship of the data to the clock.
- BRG Timer Interrupt Request
0 = BRG timer function is disabled
1 = BRG time-out interrupt is enabled
- Start an SPI Interrupt Request
0 = No effect
1 = Generate an SPI interrupt request
- Interrupt Request Enable
0 = SPI interrupt requests are disabled
1 = SPI interrupt requests are enabled

SPI Status

SPISTAT (F62H - Read Only)

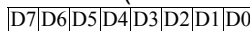

- Slave Select
0 = If Slave, \overline{SS} pin is asserted
1 = If Slave, \overline{SS} pin is not asserted
- Transmit Status
0 = No data transmission in progress
1 = Data transmission now in progress
- Reserved
- Slave Mode Transaction Abort
0 = No slave mode transaction abort detected
1 = Slave mode transaction abort was detected
- Collision
0 = No multi-master collision detected
1 = Multi-master collision was detected
- Overrun
0 = No overrun error detected
1 = Overrun error was detected
- Interrupt Request
0 = No SPI interrupt request pending
1 = SPI interrupt request is pending

SPI Mode

SPIMODE (F63H - Read/Write)

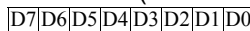

- Slave Select Value
If Master and SPIMODE[1] = 1:
0 = \overline{SS} pin driven Low
1 = \overline{SS} pin driven High
- Slave Select I/O
0 = \overline{SS} pin configured as an input
1 = \overline{SS} pin configured as an output (Master mode only)
- Number of Data Bits Per Character
000 = 8 bits
001 = 1 bit
010 = 2 bits
011 = 3 bits
100 = 4 bits
101 = 5 bit
110 = 6 bits

SPI Mode

SPIMODE (F63H - Read/Write)

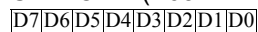

111 = 7 bits

Diagnostic Mode Control
0 = Reading from SPIBRH, SPIBRL
returns reload values
1 = Reading from SPIBRH, SPIBRL
returns current BRG count value

Reserved

SPI Diagnostic State

SPIDST (F64H - Read Only)

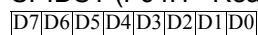

SPI State

Transmit Clock Enable
0 = Internal transmit clock enable
signal is deasserted
1 = Internal transmit clock enable
signal is asserted

Shift Clock Enable
0 = Internal shift clock enable signal
is deasserted
1 = Internal shift clock enable signal
is asserted

SPI Baud Rate Generator High Byte

SPIBRH (F66H - Read/Write)

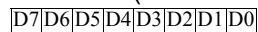

SPI Baud Rate divisor [15:8]

SPI Baud Rate Generator Low Byte

SPIBRL (F67H - Read/Write)

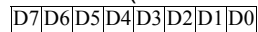

SPI Baud Rate divisor [7:0]

ADC Control

ADCCTL (F70H - Read/Write)

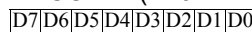

Analog Input Select
0000 = ANA0 0001 = ANA1
0010 = ANA2 0011 = ANA3
0100 = ANA4 0101 = ANA5
0110 = ANA6 0111 = ANA7
1000 = ANA8 1001 = ANA9
1010 = ANA10 1011 = ANA11
11xx = Reserved

Continuous Mode Select
0 = Single-shot conversion
1 = Continuous conversion

External VREF select
0 = Internal voltage reference
selected
1 = External voltage reference
selected

Reserved

Conversion Enable
0 = Conversion is complete
1 = Begin conversion

ADC Data High Byte

ADCD_H (F72H - Read Only)

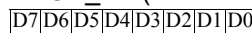

ADC Data [9:2]

ADC Data Low Bits

ADCD_L (F73H - Read Only)

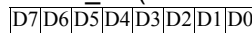

Reserved

ADC Data [1:0]



DMA0 Control

DMA0CTL (FB0H - Read/Write)

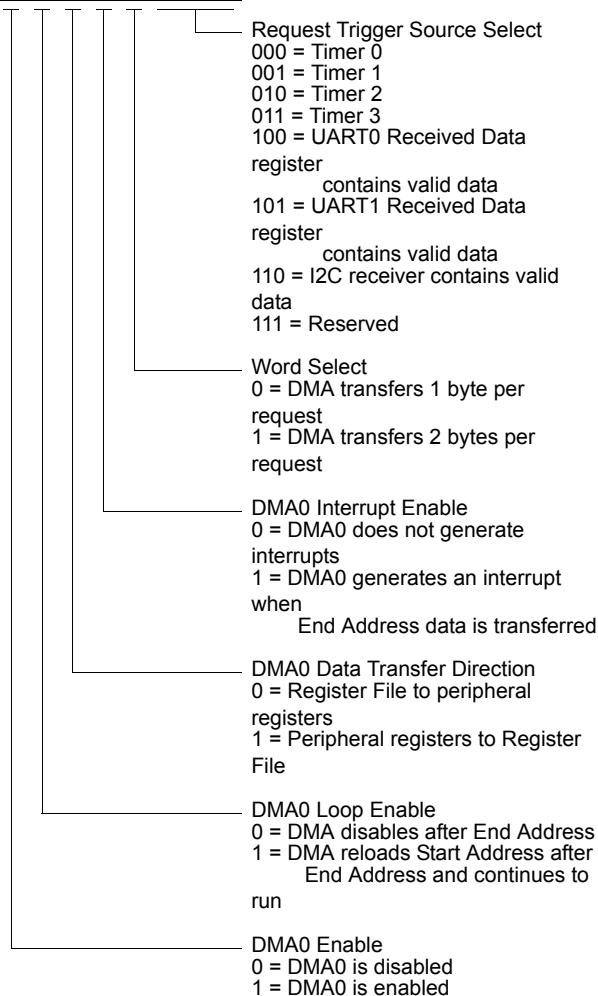
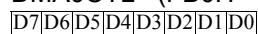

DMA0 Address High Nibble

DMA0H (FB2H - Read/Write)

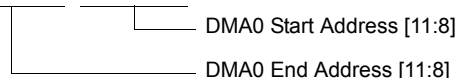
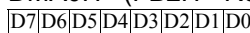

DMA0 Start/Current Address Low Byte

DMA0START (FB3H - Read/Write)

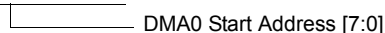
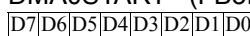

DMA0 End Address Low Byte

DMA0END (FB4H - Read/Write)

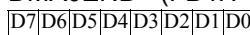

DMA0 I/O Address

DMA0IO (FB1H - Read/Write)

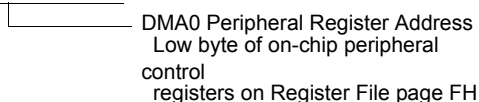
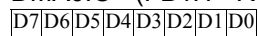



DMA1 Control

DMA1CTL (FB8H - Read/Write)

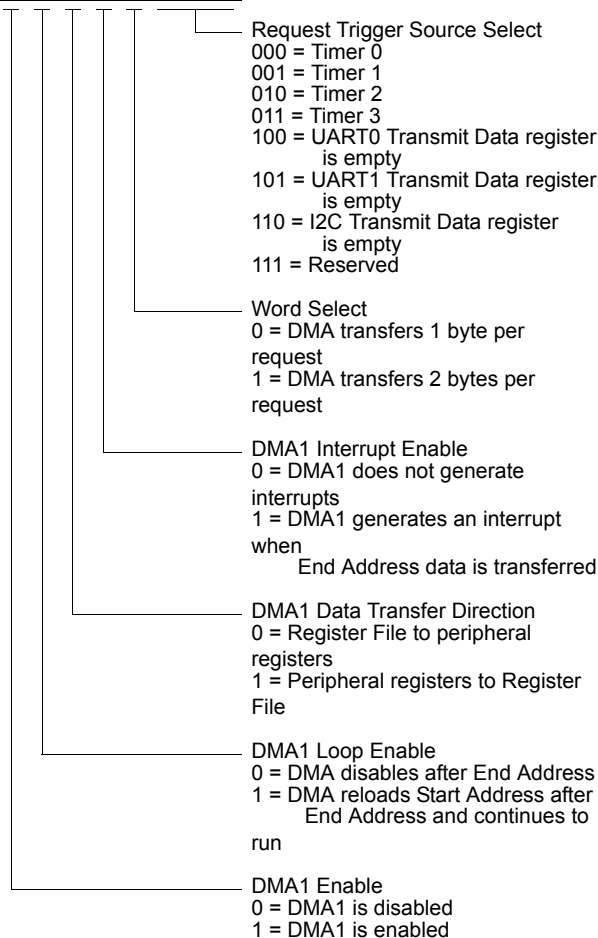
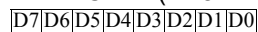

DMA1 Address High Nibble

DMA1H (FBAH - Read/Write)

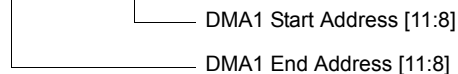
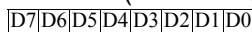

DMA1 Start/Current Address Low Byte

DMA1START (FBBH - Read/Write)

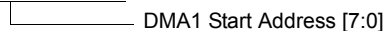
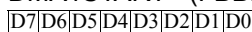

DMA1 End Address Low Byte

DMA1END (FBCH - Read/Write)

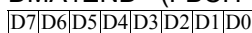

DMA_ADC Address

DMAA_ADDR (FBDH - Read/Write)

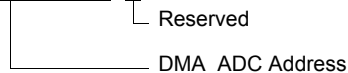
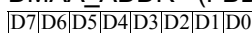

DMA1 I/O Address

DMA1IO (FB9H - Read/Write)

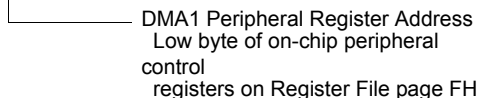
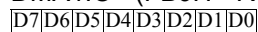

DMA_ADC Control

DMAACTL (FBEH - Read/Write)

D7 D6 D5 D4 D3 D2 D1 D0

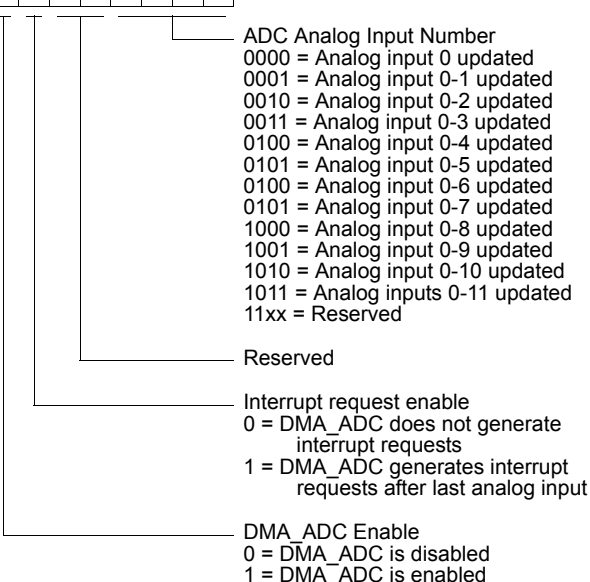

Interrupt Request 0

IRQ0 (FC0H - Read/Write)

D7 D6 D5 D4 D3 D2 D1 D0

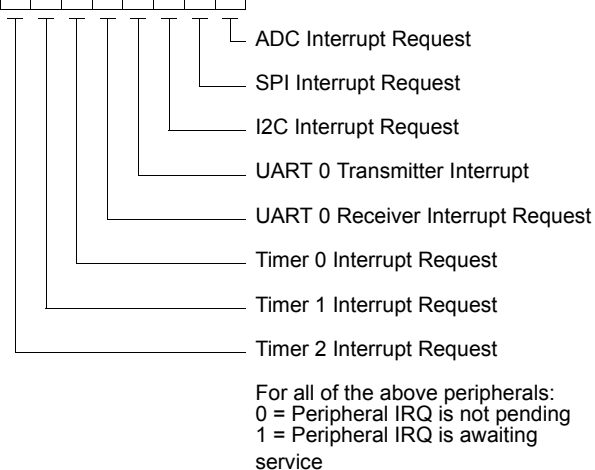

DMA Status

DMAA_STAT (FBFH - Read Only)

D7 D6 D5 D4 D3 D2 D1 D0

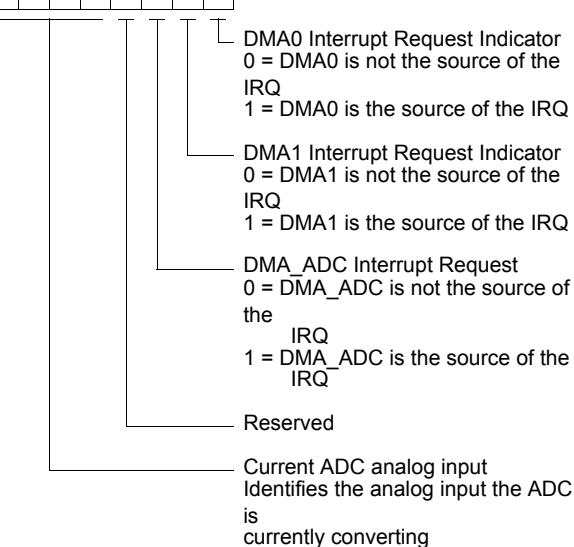

IRQ0 Enable High Bit

IRQ0ENH (FC1H - Read/Write)

D7 D6 D5 D4 D3 D2 D1 D0

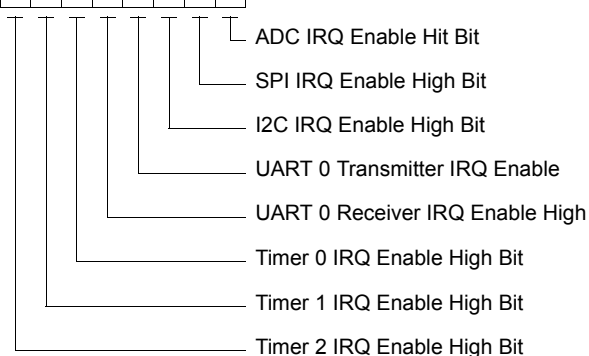

IRQ0 Enable Low Bit

IRQ0ENL (FC2H - Read/Write)

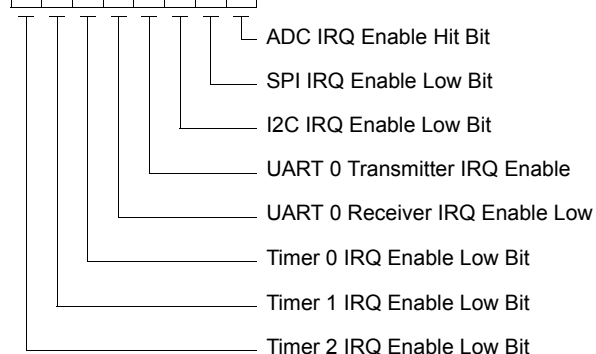
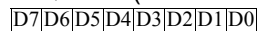

Interrupt Request 2

IRQ2 (FC6H - Read/Write)

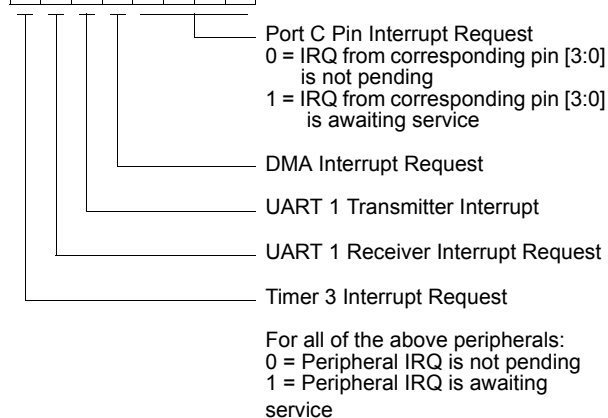
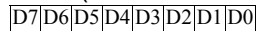

Interrupt Request 1

IRQ1 (FC3H - Read/Write)

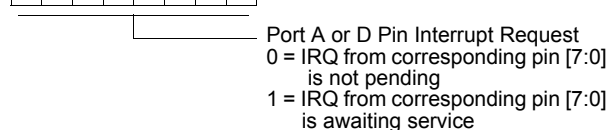
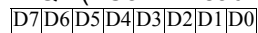

IRQ2 Enable High Bit

IRQ2ENH (FC7H - Read/Write)

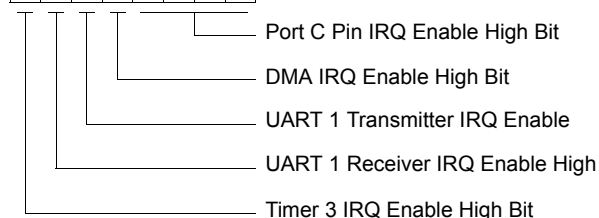
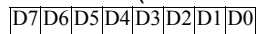

IRQ1 Enable High Bit

IRQ1ENH (FC4H - Read/Write)

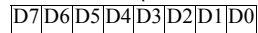

IRQ1 Enable Low Bit

IRQ1ENL (FC5H - Read/Write)

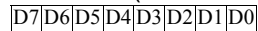

IRQ2 Enable Low Bit

IRQ2ENL (FC8H - Read/Write)

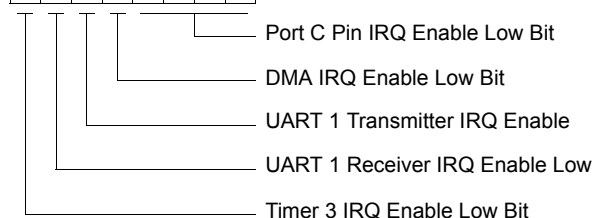
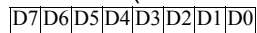

Interrupt Edge Select

IRQES (FCDH - Read/Write)

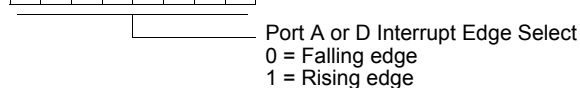
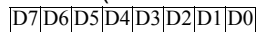



Interrupt Port Select

IRQPS (FCEH - Read/Write)

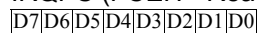

Port A or D Port Pin Select [7:0]
0 = Port A pin is the interrupt source
1 = Port D pin is the interrupt source

Interrupt Control

IRQCTL (FCFH - Read/Write)

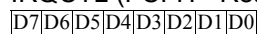

Reserved
Interrupt Request Enable
0 = Interrupts are disabled
1 = Interrupts are enabled

Port A Address

PAADDR (FD0H - Read/Write)

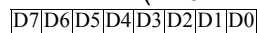

Port A Address[7:0]
Selects Port Sub-Registers:
00H = No function
01H = Data direction
02H = Alternate function
03H = Output control (open-drain)
04H = High drive enable
05H = Stop Mode Recovery enable
06H-FFH = No function

Port A Control

PACTL (FD1H - Read/Write)

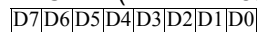

Port A Control[7:0]
Provides Access to Port Sub-Registers

Port A Input Data

PAIN (FD2H - Read Only)

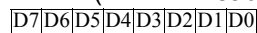

Port A Input Data [7:0]

Port A Output Data

PAOUT (FD3H - Read/Write)

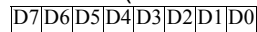

Port A Output Data [7:0]

Port B Address

PBADDR (FD4H - Read/Write)

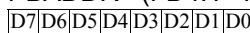

Port B Address[7:0]
Selects Port Sub-Registers:
00H = No function
01H = Data direction
02H = Alternate function
03H = Output control (open-drain)
04H = High drive enable
05H = Stop Mode Recovery enable
06H-FFH = No function

Port B Control

PBCTL (FD5H - Read/Write)

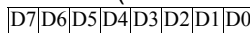

Port B Control[7:0]
Provides Access to Port Sub-Registers

Port B Input Data

PBIN (FD6H - Read Only)

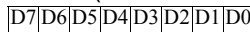

Port B Input Data [7:0]

Port B Output Data

PBOUT (FD7H - Read/Write)

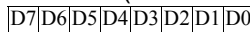

Port B Output Data [7:0]

Port C Address

PCADDR (FD8H - Read/Write)

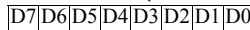

Port C Address[7:0]
Selects Port Sub-Registers:
00H = No function
01H = Data direction
02H = Alternate function
03H = Output control (open-drain)
04H = High drive enable
05H = Stop Mode Recovery enable
06H-FFH = No function

Port C Control

PCCTL (FD9H - Read/Write)

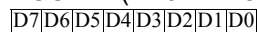

Port C Control[7:0]
Provides Access to Port Sub-Registers

Port D Output Data

PDOUT (FDFH - Read/Write)

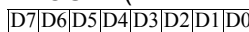

Port D Output Data [7:0]

Port C Input Data

PCIN (FDAH - Read Only)

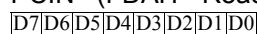

Port C Input Data [7:0]

Port E Address

PEADDR (FE0H - Read/Write)

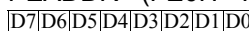

Port E Address[7:0]
Selects Port Sub-Registers:
00H = No function
01H = Data direction
02H = Alternate function
03H = Output control (open-drain)
04H = High drive enable
05H = Stop Mode Recovery enable
06H-FFH = No function

Port C Output Data

PCOUT (FDBH - Read/Write)

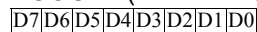

Port C Output Data [7:0]

Port E Control

PECTL (FE1H - Read/Write)

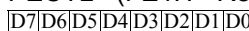

Port E Control[7:0]
Provides Access to Port Sub-Registers

Port D Address

PDADDR (FDCH - Read/Write)



Port D Address[7:0]
Selects Port Sub-Registers:
00H = No function
01H = Data direction
02H = Alternate function
03H = Output control (open-drain)
04H = High drive enable
05H = Stop Mode Recovery enable
06H-FFH = No function

Port E Input Data

PEIN (FE2H - Read Only)

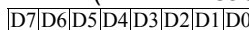

Port E Input Data [7:0]

Port D Control

PDCTL (FDDH - Read/Write)

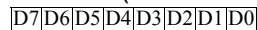

Port D Control[7:0]
Provides Access to Port Sub-Registers

Port E Output Data

PEOUT (FE3H - Read/Write)

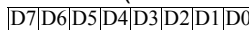

Port E Output Data [7:0]

Port D Input Data

PDIN (FDE H- Read Only)



Port D Input Data [7:0]

Port F Address

PFADDR (FE4H - Read/Write)

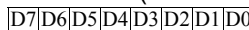

Port F Address[7:0]
Selects Port Sub-Registers:
00H = No function
01H = Data direction
02H = Alternate function
03H = Output control (open-drain)
04H = High drive enable
05H = Stop Mode Recovery enable
06H-FFH = No function

Port F Control

PFCTL (FE5H - Read/Write)

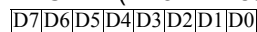

Port F Control[7:0]
Provides Access to Port Sub-Registers

Port F Input Data

PFIN (FE6H - Read Only)

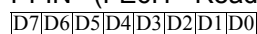

Port F Input Data [7:0]

Port F Output Data

PFOUT (FE7H - Read/Write)

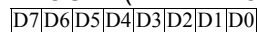

Port F Output Data [7:0]

Port G Address

PGADDR (FE8H - Read/Write)



Port G Address[7:0]
Selects Port Sub-Registers:
00H = No function
01H = Data direction
02H = Alternate function
03H = Output control (open-drain)
04H = High drive enable
05H = Stop Mode Recovery enable
06H-FFH = No function

Port G Control

PGCTL (FE9H - Read/Write)

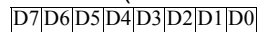

Port G Control[7:0]
Provides Access to Port Sub-Registers

Port G Input Data

PGIN (FEAH - Read Only)

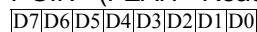

Port G Input Data [7:0]

Port G Output Data

PGOUT (FEBH - Read/Write)

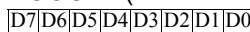

Port G Output Data [7:0]

Port H Address

PHADDR (FECH - Read/Write)

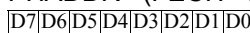

Port H Address[7:0]
Selects Port Sub-Registers:
00H = No function
01H = Data direction
02H = Alternate function
03H = Output control (open-drain)
04H = High drive enable
05H = Stop Mode Recovery enable
06H-FFH = No function

Port H Control

PHCTL (FEDH - Read/Write)

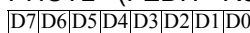

Port H Control [3:0]
Provides Access to Port Sub-Registers
Reserved

Port H Input Data

PHIN (FEEH - Read Only)



Port H Input Data [3:0]
Reserved

Port H Output Data

PHOUT (FEFH - Read/Write)

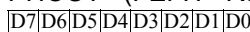

Port H Output Data [3:0]
Reserved



Watchdog Timer Control

WDTCTL (FF0H - Read Only)

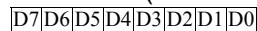

- SM Configuration Indicator
Reserved
- EXT
0 = Reset not generated by $\overline{\text{RESET}}$ pin
1 = Reset generated by $\overline{\text{RESET}}$ pin
- WDT
0 = WDT timeout has not occurred
1 = WDT timeout occurred
- STOP
0 = SMR has not occurred
1 = SMR has occurred
- POR
0 = POR has not occurred
1 = POR has occurred

Flash Status

FSTAT (FF8H - Read Only)

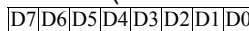

- Flash Controller Status
00_0000 = Flash controller locked
00_0001 = First unlock received
00_0010 = Second unlock received
00_0011 = Flash controller unlocked
00_0100 = Flash Sector Protect register selected
00_1xxx = Programming in progress
01_0xxx = Page erase in progress
10_0xxx = Mass erase in progress
- Reserved

Watchdog Timer Reload Upper Byte

WDTU (FF1H - Read/Write)

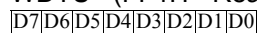

WDT reload value [23:16]

Page Select

FPS (FF9H - Read/Write)

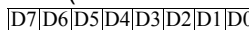

- Page Select [6:0]
Identifies the Flash memory page for Page Erase operation.
- Information Area Enable
0 = Information Area access is disabled
1 = Information Area access is enabled

Watchdog Timer Reload Middle Byte

WDTH (FF2H - Read/Write)

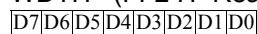

WDT reload value [15:8]

Flash Sector Protect

FPROT (FF9H - Read/Write to 1's)

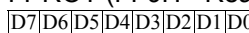

- Flash Sector Protect [7:0]
0 = Sector can be programmed or erased from user code
1 = Sector is protected and cannot be programmed or erased from user code

Watchdog Timer Reload Low Byte

WDTL (FF3H - Read/Write)

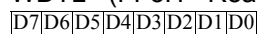

WDT reload value [7:0]

Flash Control

FCTL (FF8H - Write Only)

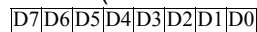

- Flash Command
73H = First unlock command
8CH = Second unlock command
95H = Page erase command
63H = Mass erase command
5EH = Flash Sector Protect reg select

Flash Frequency High Byte

FFREQH (FFAH - Read/Write)

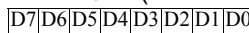

Flash Frequency value [15:8]

Flash Frequency Low Byte

FFREQL (FFBH - Read/Write)

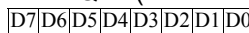

Flash Frequency value [7:0]

Flags

FLAGS (FFC - Read/Write)

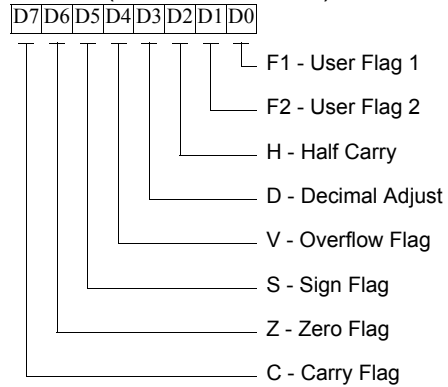

Register Pointer

RP (FFDH - Read/Write)

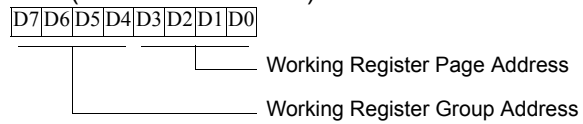

Stack Pointer High Byte

SPH (FFEH - Read/Write)

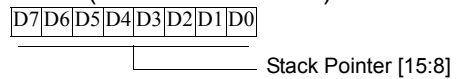

Stack Pointer Low Byte

SPL (FFFH - Read/Write)

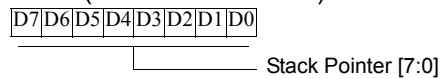

Reset and Stop Mode Recovery

Overview

The Reset Controller within the Z8 Encore! XP 64K Series Flash Microcontrollers controls Reset and Stop Mode Recovery operation. In typical operation, the following events cause a Reset to occur:

- Power-On Reset
- Voltage Brownout
- Watchdog Timer time-out (when configured via the WDT_RES Option Bit to initiate a Reset)
- External $\overline{\text{RESET}}$ pin assertion
- On-Chip Debugger initiated Reset (OCDCTL[0] set to 1)

When the 64K Series devices are in STOP mode, a Stop Mode Recovery is initiated by either of the following:

- Watchdog Timer time-out
- GPIO Port input pin transition on an enabled Stop Mode Recovery source
- DBG pin driven Low

Reset Types

The 64K Series provides two different types of reset operation (system reset and Stop Mode Recovery). The type of Reset is a function of both the current operating mode of the 64K Series devices and the source of the Reset. [Table 8](#) lists the types of Reset and their operating characteristics.

Table 8. Reset and Stop Mode Recovery Characteristics and Latency

Reset Type	Reset Characteristics and Latency		
	Control Registers	eZ8 [™] CPU	Reset Latency (Delay)
System reset	Reset (as applicable)	Reset	66 WDT Oscillator cycles + 16 System Clock cycles
Stop Mode Recovery	Unaffected, except WDT_CTL register	Reset	66 WDT Oscillator cycles + 16 System Clock cycles

System Reset

During a system reset, the 64K Series devices are held in Reset for 66 cycles of the Watchdog Timer oscillator followed by 16 cycles of the system clock. At the beginning of Reset, all GPIO pins are configured as inputs.

During Reset, the eZ8 CPU and on-chip peripherals are idle; however, the on-chip crystal oscillator and Watchdog Timer oscillator continue to run. The system clock begins operating following the Watchdog Timer oscillator cycle count. The eZ8 CPU and on-chip peripherals remain idle through the 16 cycles of the system clock.

Upon Reset, control registers within the Register File that have a defined Reset value are loaded with their reset values. Other control registers (including the Stack Pointer, Register Pointer, and Flags) and general-purpose RAM are undefined following Reset. The eZ8 CPU fetches the Reset vector at Program Memory addresses 0002H and 0003H and loads that value into the Program Counter. Program execution begins at the Reset vector address.

Reset Sources

[Table 9](#) lists the reset sources as a function of the operating mode. The text following provides more detailed information on the individual Reset sources. A Power-On Reset/Voltage Brownout event always takes priority over all other possible reset sources to ensure a full system reset occurs.

Table 9. Reset Sources and Resulting Reset Type

Operating Mode	Reset Source	Reset Type
NORMAL or HALT modes	Power-On Reset/Voltage Brownout	system reset
	Watchdog Timer time-out when configured for Reset	system reset
	$\overline{\text{RESET}}$ pin assertion	system reset
	On-Chip Debugger initiated Reset (OCDCTL[0] set to 1)	system reset except the On-Chip Debugger is unaffected by the reset
STOP mode	Power-On Reset/Voltage Brownout	system reset
	$\overline{\text{RESET}}$ pin assertion	system reset
	DBG pin driven Low	system reset

Power-On Reset

Each device in the 64K Series contains an internal Power-On Reset circuit. The POR circuit monitors the supply voltage and holds the device in the Reset state until the supply voltage reaches a safe operating level. After the supply voltage exceeds the POR voltage threshold (V_{POR}), the POR Counter is enabled and counts 66 cycles of the Watchdog Timer oscillator. After the POR counter times out, the XTAL Counter is enabled to count a total of 16 system clock pulses. The devices are held in the Reset state until both the POR Counter and XTAL counter have timed out. After the 64K Series devices exit the Power-On Reset state, the eZ8 CPU fetches the Reset vector. Following Power-On Reset, the POR status bit in the Watchdog Timer Control (WDTCTL) register is set to 1.

[Figure 8](#) displays Power-On Reset operation. For the POR threshold voltage (V_{POR}), see [Electrical Characteristics](#) on page 215.

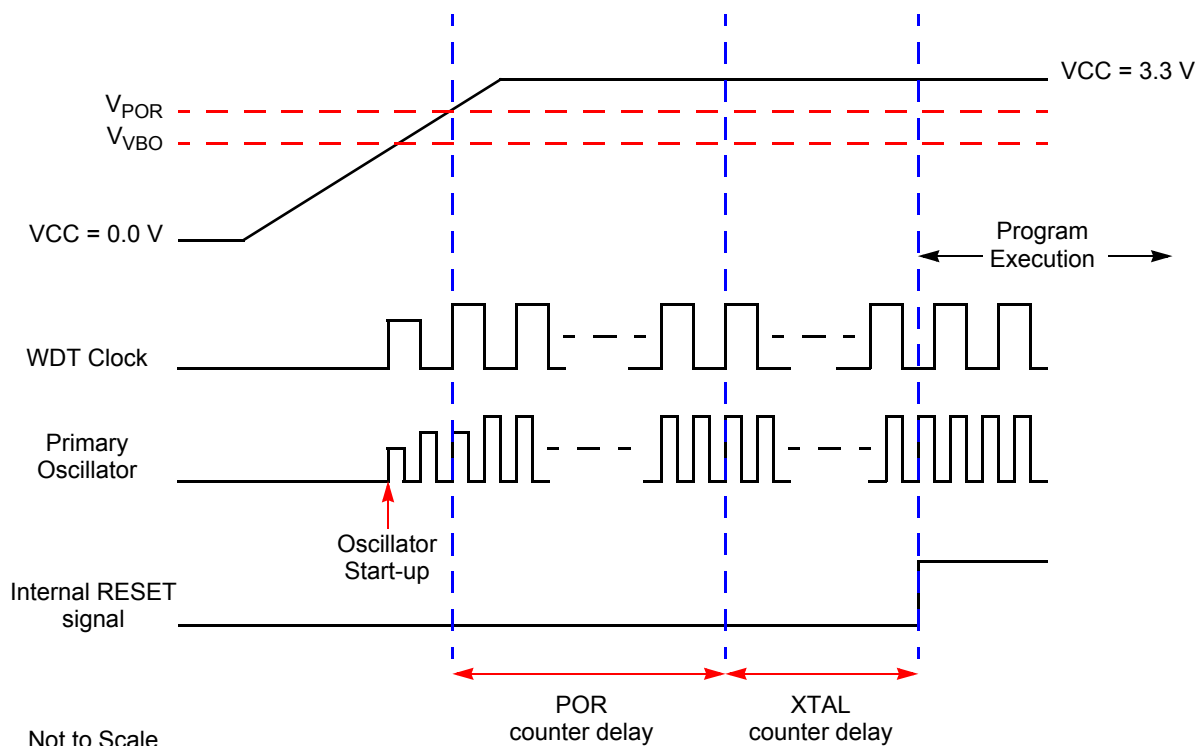

Figure 8. Power-On Reset Operation

Voltage Brownout Reset

The devices in the 64K Series provide low Voltage Brownout protection. The VBO circuit senses when the supply voltage drops to an unsafe level (below the VBO threshold voltage) and forces the device into the Reset state. While the supply voltage remains below the Power-On Reset voltage threshold (V_{POR}), the VBO block holds the device in the Reset state.

After the supply voltage again exceeds the Power-On Reset voltage threshold, the devices progress through a full system reset sequence, as described in the Power-On Reset section. Following Power-On Reset, the POR status bit in the Watchdog Timer Control (WDTCTL) register is set to 1. [Figure 9](#) displays Voltage Brownout operation. For the VBO and POR threshold voltages (V_{VBO} and V_{POR}), see [Electrical Characteristics](#) on page 215.

The Voltage Brownout circuit can be either enabled or disabled during STOP mode. Operation during STOP mode is set by the VBO_AO Option Bit. For information on configuring VBO_AO, see [Option Bits](#) page 195.

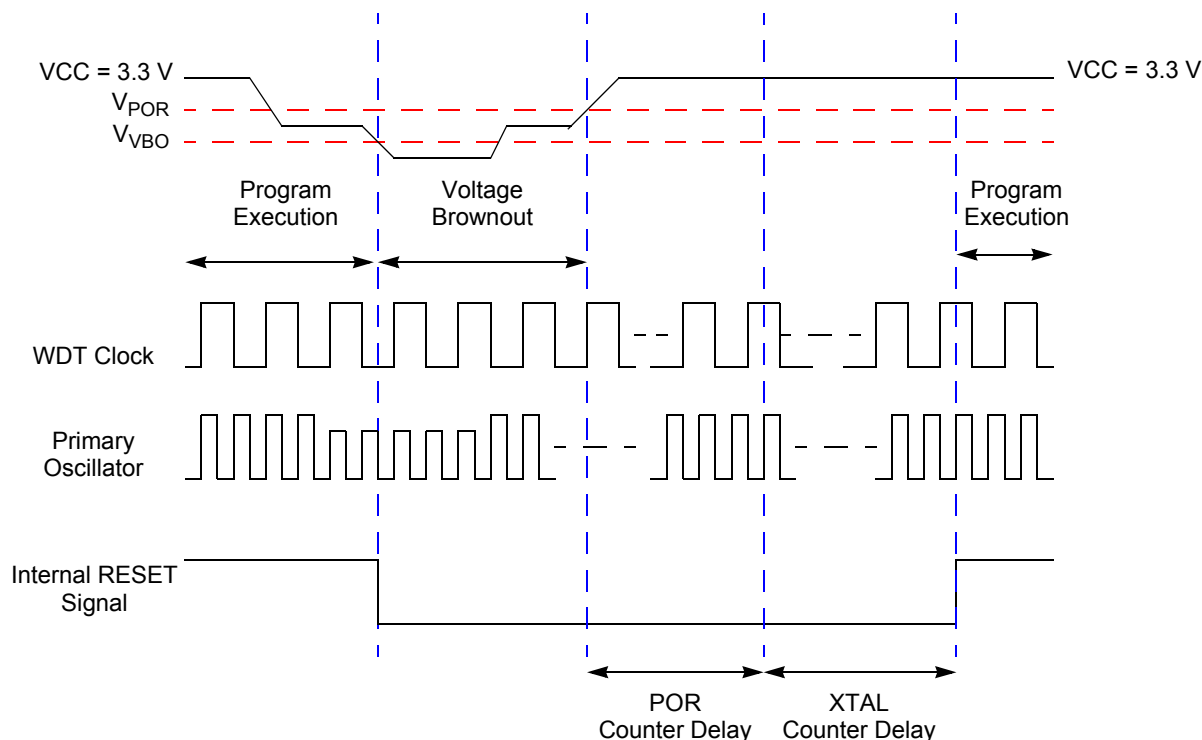

Figure 9. Voltage Brownout Reset Operation

Watchdog Timer Reset

If the device is in normal or HALT mode, the Watchdog Timer can initiate a system reset at time-out if the WDT_RES Option Bit is set to 1. This capability is the default (unprogrammed) setting of the WDT_RES Option Bit. The WDT status bit in the WDT Control register is set to signify that the reset was initiated by the Watchdog Timer.

External Pin Reset

The $\overline{\text{RESET}}$ pin has a Schmitt-triggered input, an internal pull-up, an analog filter and a digital filter to reject noise. Once the $\overline{\text{RESET}}$ pin is asserted for at least 4 system clock cycles, the devices progress through the system reset sequence. While the $\overline{\text{RESET}}$ input pin is asserted Low, the 64K Series devices continue to be held in the Reset state. If the $\overline{\text{RESET}}$ pin is held Low beyond the system reset time-out, the devices exit the Reset state immediately following $\overline{\text{RESET}}$ pin deassertion. Following a system reset initiated by the external $\overline{\text{RESET}}$ pin, the EXT status bit in the Watchdog Timer Control (WDTCTL) register is set to 1.

On-Chip Debugger Initiated Reset

A Power-On Reset can be initiated using the On-Chip Debugger by setting the `RST` bit in the OCD Control register. The On-Chip Debugger block is not reset but the rest of the chip goes through a normal system reset. The `RST` bit automatically clears during the system reset. Following the system reset the `POR` bit in the WDT Control register is set.

Stop Mode Recovery

STOP mode is entered by the eZ8 executing a `STOP` instruction. For detailed STOP mode information, see [Low-Power Modes](#) on page 47. During Stop Mode Recovery, the devices are held in reset for 66 cycles of the Watchdog Timer oscillator followed by 16 cycles of the system clock. Stop Mode Recovery only affects the contents of the Watchdog Timer Control register. Stop Mode Recovery does not affect any other values in the Register File, including the Stack Pointer, Register Pointer, Flags, peripheral control registers, and general-purpose RAM.

The eZ8[™] CPU fetches the Reset vector at Program Memory addresses `0002H` and `0003H` and loads that value into the Program Counter. Program execution begins at the Reset vector address. Following Stop Mode Recovery, the `STOP` bit in the Watchdog Timer Control Register is set to 1. [Table 10](#) lists the Stop Mode Recovery sources and resulting actions.

Table 10. Stop Mode Recovery Sources and Resulting Action

Operating Mode	Stop Mode Recovery Source	Action
STOP mode	Watchdog Timer time-out when configured for Reset	Stop Mode Recovery
	Watchdog Timer time-out when configured for interrupt	Stop Mode Recovery followed by interrupt (if interrupts are enabled)
	Data transition on any GPIO Port pin enabled as a Stop Mode Recovery source	Stop Mode Recovery

Stop Mode Recovery Using Watchdog Timer Time-Out

If the Watchdog Timer times out during STOP mode, the device undergoes a Stop Mode Recovery sequence. In the Watchdog Timer Control register, the `WDT` and `STOP` bits are set to 1. If the Watchdog Timer is configured to generate an interrupt upon time-out and the 64K Series devices are configured to respond to interrupts, the eZ8 CPU services the Watchdog Timer interrupt request following the normal Stop Mode Recovery sequence.

Stop Mode Recovery Using a GPIO Port Pin Transition HALT

Each of the GPIO Port pins may be configured as a Stop Mode Recovery input source. On any GPIO pin enabled as a Stop Mode Recovery source, a change in the input pin value (from High to Low or from Low to High) initiates Stop Mode Recovery. The GPIO Stop Mode Recovery signals are filtered to reject pulses less than 10 ns (typical) in duration. In the Watchdog Timer Control register, the STOP bit is set to 1.



Caution: *In STOP mode, the GPIO Port Input Data registers (PxIN) are disabled. The Port Input Data registers record the Port transition only if the signal stays on the Port pin through the end of the Stop Mode Recovery delay. Thus, short pulses on the Port pin can initiate Stop Mode Recovery without being written to the Port Input Data register or without initiating an interrupt (if enabled for that pin).*



Low-Power Modes

Overview

The 64K Series products contain power-saving features. The highest level of power reduction is provided by STOP mode. The next level of power reduction is provided by the HALT mode.

STOP Mode

Execution of the eZ8[™] CPU's STOP instruction places the device into STOP mode. In STOP mode, the operating characteristics are:

- Primary crystal oscillator is stopped; the XIN pin is driven High and the XOUT pin is driven Low.
- System clock is stopped.
- eZ8 CPU is stopped.
- Program counter (PC) stops incrementing.
- The Watchdog Timer and its internal RC oscillator continue to operate, if enabled for operation during STOP mode.
- The Voltage Brownout protection circuit continues to operate, if enabled for operation in STOP mode using the associated Option Bit.
- All other on-chip peripherals are idle.

To minimize current in STOP mode, all GPIO pins that are configured as digital inputs must be driven to one of the supply rails (V_{CC} or GND), the Voltage Brownout protection must be disabled, and the Watchdog Timer must be disabled. The devices can be brought out of STOP mode using Stop Mode Recovery. For more information on Stop Mode Recovery, see [Reset and Stop Mode Recovery](#) on page 47.



Caution: *STOP mode must not be used when driving the 64K Series devices with an external clock driver source.*

HALT Mode

Execution of the eZ8 CPU's HALT instruction places the device into HALT mode. In HALT mode, the operating characteristics are:

- Primary crystal oscillator is enabled and continues to operate.
- System clock is enabled and continues to operate.
- eZ8 CPU is stopped.
- Program Counter stops incrementing.
- Watchdog Timer's internal RC oscillator continues to operate.
- The Watchdog Timer continues to operate, if enabled.
- All other on-chip peripherals continue to operate.

The eZ8 CPU can be brought out of HALT mode by any of the following operations:

- Interrupt
- Watchdog Timer time-out (interrupt or reset)
- Power-On Reset
- Voltage Brownout Reset
- External $\overline{\text{RESET}}$ pin assertion

To minimize current in HALT mode, all GPIO pins which are configured as inputs must be driven to one of the supply rails (V_{CC} or GND).

General-Purpose I/O

Overview

The 64K Series products support a maximum of seven 8-bit ports (Ports A–G) and one 4-bit port (Port H) for general-purpose input/output (GPIO) operations. Each port consists of control and data registers. The GPIO control registers are used to determine data direction, open-drain, output drive current and alternate pin functions. Each port pin is individually programmable. All ports (except B and H) support 5 V-tolerant inputs.

GPIO Port Availability By Device

Table 11 lists the port pins available with each device and package type.

Table 11. Port Availability by Device and Package Type

Device	Packages	Port A	Port B	Port C	Port D	Port E	Port F	Port G	Port H
Z8X1621	40-pin	[7:0]	[7:0]	[6:0]	[6:3, 1:0]	-	-	-	-
Z8X1621	44-pin	[7:0]	[7:0]	[7:0]	[6:0]	-	-	-	-
Z8X1622	64- and 68-pin	[7:0]	[7:0]	[7:0]	[7:0]	[7:0]	[7]	[3]	[3:0]
Z8X2421	40-pin	[7:0]	[7:0]	[6:0]	[6:3, 1:0]	-	-	-	-
Z8X2421	44-pin	[7:0]	[7:0]	[7:0]	[6:0]	-	-	-	-
Z8X2422	64- and 68-pin	[7:0]	[7:0]	[7:0]	[7:0]	[7:0]	[7]	[3]	[3:0]
Z8X3221	40-pin	[7:0]	[7:0]	[6:0]	[6:3, 1:0]	-	-	-	-
Z8X3221	44-pin	[7:0]	[7:0]	[7:0]	[6:0]	-	-	-	-
Z8X3222	64- and 68-pin	[7:0]	[7:0]	[7:0]	[7:0]	[7:0]	[7]	[3]	[3:0]
Z8X4821	40-pin	[7:0]	[7:0]	[6:0]	[6:3, 1:0]	-	-	-	-
Z8X4821	44-pin	[7:0]	[7:0]	[7:0]	[6:0]	-	-	-	-
Z8X4822	64- and 68-pin	[7:0]	[7:0]	[7:0]	[7:0]	[7:0]	[7]	[3]	[3:0]

Table 11. Port Availability by Device and Package Type (Continued)

Device	Packages	Port A	Port B	Port C	Port D	Port E	Port F	Port G	Port H
Z8X4823	80-pin	[7:0]	[7:0]	[7:0]	[7:0]	[7:0]	[7:0]	[7:0]	[3:0]
Z8X6421	40-pin	[7:0]	[7:0]	[6:0]	[6:3, 1:0]	-	-	-	-
Z8X6421	44-pin	[7:0]	[7:0]	[7:0]	[6:0]	-	-	-	-
Z8X6422	64- and 68-pin	[7:0]	[7:0]	[7:0]	[7:0]	[7:0]	[7]	[3]	[3:0]
Z8X6423	80-pin	[7:0]	[7:0]	[7:0]	[7:0]	[7:0]	[7:0]	[7:0]	[3:0]

Architecture

Figure 10 displays a simplified block diagram of a GPIO port pin. In Figure 10, the ability to accommodate alternate functions and variable port current drive strength are not illustrated.

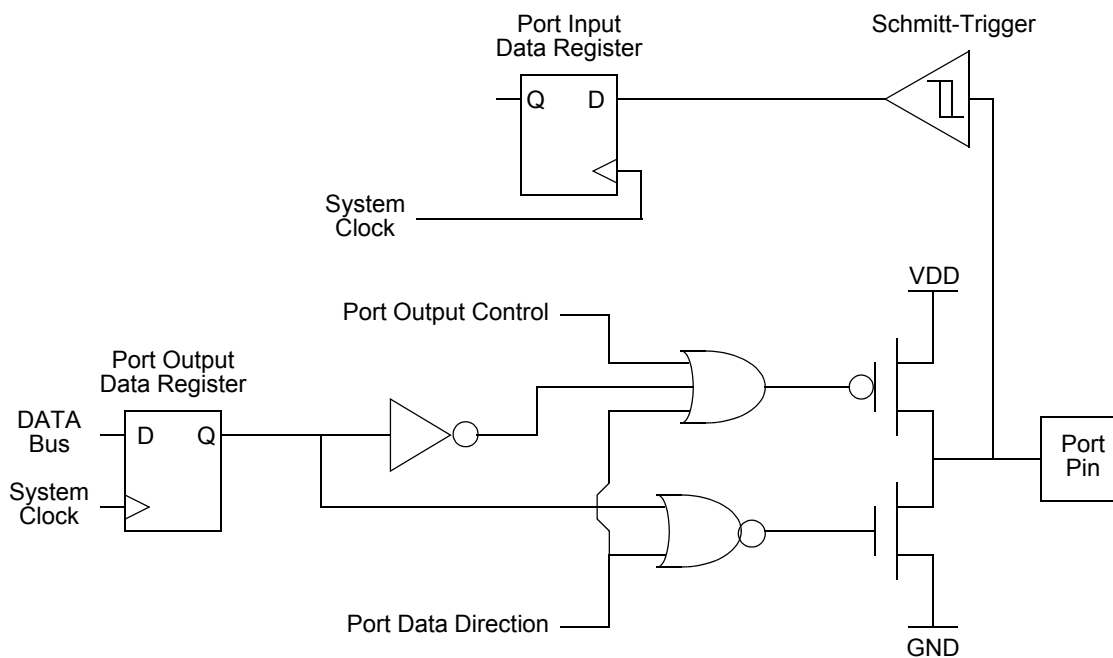

Figure 10. GPIO Port Pin Block Diagram

GPIO Alternate Functions

Many of the GPIO port pins can be used as both general-purpose I/O and to provide access to on-chip peripheral functions such as the timers and serial communication devices. The Port A–H Alternate Function sub-registers configure these pins for either general-purpose I/O or alternate function operation. When a pin is configured for alternate function, control of the port pin direction (input/output) is passed from the Port A–H Data Direction registers to the alternate function assigned to this pin. [Table 12](#) lists the alternate functions associated with each port pin.

Table 12. Port Alternate Function Mapping

Port	Pin	Mnemonic	Alternate Function Description
Port A	PA0	T0IN	Timer 0 Input
	PA1	T0OUT	Timer 0 Output
	PA2	DE0	UART 0 Driver Enable
	PA3	CTS0	UART 0 Clear to Send
	PA4	RXD0/IRRX0	UART 0/IrDA 0 Receive Data
	PA5	TXD0/IRTX0	UART 0/IrDA 0 Transmit Data
	PA6	SCL	I ² C Clock (automatically open-drain)
	PA7	SDA	I ² C Data (automatically open-drain)
Port B	PB0	ANA0	ADC Analog Input 0
	PB1	ANA1	ADC Analog Input 1
	PB2	ANA2	ADC Analog Input 2
	PB3	ANA3	ADC Analog Input 3
	PB4	ANA4	ADC Analog Input 4
	PB5	ANA5	ADC Analog Input 5
	PB6	ANA6	ADC Analog Input 6
	PB7	ANA7	ADC Analog Input 7

Table 12. Port Alternate Function Mapping (Continued)

Port	Pin	Mnemonic	Alternate Function Description
Port C	PC0	T1IN	Timer 1 Input
	PC1	T1OUT	Timer 1 Output
	PC2	SS	SPI Slave Select
	PC3	SCK	SPI Serial Clock
	PC4	MOSI	SPI Master Out/Slave In
	PC5	MISO	SPI Master In/Slave Out
	PC6	T2IN	Timer 2 In
	PC7	T2OUT	Timer 2 Out
Port D	PD0	T3IN	Timer 3 In (unavailable in 44-pin packages)
	PD1	T3OUT	Timer 3 Out (unavailable in 44-pin packages)
	PD2	N/A	No alternate function
	PD3	DE1	UART 1 Driver Enable
	PD4	RXD1/IRRX1	UART 1/IrDA 1 Receive Data
	PD5	TXD1/IRTX1	UART 1/IrDA 1 Transmit Data
	PD6	CTS1	UART 1 Clear to Send
	PD7	RCOUT	Watchdog Timer RC Oscillator Output
Port E	PE[7:0]	N/A	No alternate functions
Port F	PF[7:0]	N/A	No alternate functions
Port G	PG[7:0]	N/A	No alternate functions
Port H	PH0	ANA8	ADC Analog Input 8
	PH1	ANA9	ADC Analog Input 9
	PH2	ANA10	ADC Analog Input 10
	PH3	ANA11	ADC Analog Input 11

GPIO Interrupts

Many of the GPIO port pins can be used as interrupt sources. Some port pins may be configured to generate an interrupt request on either the rising edge or falling edge of the pin input signal. Other port pin interrupts generate an interrupt when any edge occurs (both rising and falling). For more information on interrupts using the GPIO pins, see [Interrupt Controller](#) on page 67.

GPIO Control Register Definitions

Four registers for each Port provide access to GPIO control, input data, and output data. [Table 13](#) lists these Port registers. Use the Port A–H Address and Control registers together to provide access to sub-registers for Port configuration and control.

Table 13. GPIO Port Registers and Sub-Registers

Port Register Mnemonic	Port Register Name
PxADDR	Port A–H Address Register (Selects sub-registers)
PxCTL	Port A–H Control Register (Provides access to sub-registers)
PxIN	Port A–H Input Data Register
PxOUT	Port A–H Output Data Register
Port Sub-Register Mnemonic	Port Register Name
PxDD	Data Direction
PxAF	Alternate Function
PxOC	Output Control (Open-Drain)
PxHDE	High Drive Enable
PxSMRE	Stop Mode Recovery Source Enable

Port A–H Address Registers

The Port A–H Address registers select the GPIO Port functionality accessible through the Port A–H Control registers. The Port A–H Address and Control registers combine to provide access to all GPIO Port control ([Table 14](#)).

Table 14. Port A–H GPIO Address Registers (PxADDR)

BITS	7	6	5	4	3	2	1	0
FIELD	PADDR[7:0]							
RESET	00H							
R/W	R/W							
ADDR	FD0H, FD4H, FD8H, FDCH, FE0H, FE4H, FE8H, FECH							



PADDR[7:0]—Port Address

The Port Address selects one of the sub-registers accessible through the Port Control register.

PADDR[7:0]	Port Control sub-register accessible using the Port A–H Control Registers
00H	No function. Provides some protection against accidental Port reconfiguration
01H	Data Direction
02H	Alternate Function
03H	Output Control (Open-Drain)
04H	High Drive Enable
05H	Stop Mode Recovery Source Enable
06H-FFH	No function

Port A–H Control Registers

The Port A–H Control registers set the GPIO port operation. The value in the corresponding Port A–H Address register determines the control sub-registers accessible using the Port A–H Control register ([Table 15](#)).

Table 15. Port A–H Control Registers (PxCTL)

BITS	7	6	5	4	3	2	1	0
FIELD	PCTL							
RESET	00H							
R/W	R/W							
ADDR	FD1H, FD5H, FD9H, FDDH, FE1H, FE5H, FE9H, FEDH							

PCTL[7:0]—Port Control

The Port Control register provides access to all sub-registers that configure the GPIO Port operation.

Port A–H Data Direction Sub-Registers

The Port A–H Data Direction sub-register is accessed through the Port A–H Control register by writing 01H to the Port A–H Address register (Table 16).

Table 16. Port A–H Data Direction Sub-Registers

BITS	7	6	5	4	3	2	1	0
FIELD	DD7	DD6	DD5	DD4	DD3	DD2	DD1	DD0
RESET	1							
R/W	R/W							
ADDR	If 01H in Port A–H Address Register, accessible through Port A–H Control Register							

DD[7:0]—Data Direction

These bits control the direction of the associated port pin. Port Alternate Function operation overrides the Data Direction register setting.

0 = Output. Data in the Port A–H Output Data register is driven onto the port pin.

1 = Input. The port pin is sampled and the value written into the Port A–H Input Data Register. The output driver is tri-stated.

Port A–H Alternate Function Sub-Registers

The Port A–H Alternate Function sub-register (Table 17) is accessed through the Port A–H Control register by writing 02H to the Port A–H Address register. The Port A–H Alternate Function sub-registers select the alternate functions for the selected pins. To determine the alternate function associated with each port pin, see [GPIO Alternate Functions](#) on page 59.



Caution: *Do not enable alternate function for GPIO port pins which do not have an associated alternate function. Failure to follow this guideline may result in unpredictable operation.*

Table 17. Port A–H Alternate Function Sub-Registers

BITS	7	6	5	4	3	2	1	0
FIELD	AF7	AF6	AF5	AF4	AF3	AF2	AF1	AF0
RESET	0							
R/W	R/W							
ADDR	If 02H in Port A–H Address Register, accessible through Port A–H Control Register							

AF[7:0]—Port Alternate Function enabled

0 = The port pin is in NORMAL mode and the DDx bit in the Port A–H Data Direction sub-register determines the direction of the pin.

1 = The alternate function is selected. Port pin operation is controlled by the alternate function.

Port A–H Output Control Sub-Registers

The Port A–H Output Control sub-register ([Table 18](#)) is accessed through the Port A–H Control register by writing 03H to the Port A–H Address register. Setting the bits in the Port A–H Output Control sub-registers to 1 configures the specified port pins for open-drain operation. These sub-registers affect the pins directly and, as a result, alternate functions are also affected.

Table 18. Port A–H Output Control Sub-Registers

BITS	7	6	5	4	3	2	1	0
FIELD	POC7	POC6	POC5	POC4	POC3	POC2	POC1	POC0
RESET	0							
R/W	R/W							
ADDR	If 03H in Port A–H Address Register, accessible through Port A–H Control Register							

POC[7:0]—Port Output Control

These bits function independently of the alternate function bit and disables the drains if set to 1.

0 = The drains are enabled for any output mode.

1 = The drain of the associated pin is disabled (open-drain mode).

Port A–H High Drive Enable Sub-Registers

The Port A–H High Drive Enable sub-register ([Table 19](#)) is accessed through the Port A–H Control register by writing 04H to the Port A–H Address register. Setting the bits in the Port A–H High Drive Enable sub-registers to 1 configures the specified port pins for high current output drive operation. The Port A–H High Drive Enable sub-register affects the pins directly and, as a result, alternate functions are also affected.

Table 19. Port A–H High Drive Enable Sub-Registers

BITS	7	6	5	4	3	2	1	0
FIELD	PHDE7	PHDE6	PHDE5	PHDE4	PHDE3	PHDE2	PHDE1	PHDE0
RESET	0							
R/W	R/W							
ADDR	If 04H in Port A–H Address Register, accessible through Port A–H Control Register							

PHDE[7:0]—Port High Drive Enabled

0 = The Port pin is configured for standard output current drive.

1 = The Port pin is configured for high output current drive.

Port A–H Stop Mode Recovery Source Enable Sub-Registers

The Port A–H Stop Mode Recovery Source Enable sub-register (Table 20) is accessed through the Port A–H Control register by writing 05H to the Port A–H Address register. Setting the bits in the Port A–H Stop Mode Recovery Source Enable sub-registers to 1 configures the specified Port pins as a Stop Mode Recovery source. During STOP Mode, any logic transition on a Port pin enabled as a Stop Mode Recovery source initiates Stop Mode Recovery.

Table 20. Port A–H Stop Mode Recovery Source Enable Sub-Registers

BITS	7	6	5	4	3	2	1	0
FIELD	PSMRE7	PSMRE6	PSMRE5	PSMRE4	PSMRE3	PSMRE2	PSMRE1	PSMRE0
RESET	0							
R/W	R/W							
ADDR	If 05H in Port A–H Address Register, accessible through Port A–H Control Register							

PSMRE[7:0]—Port Stop Mode Recovery Source Enabled

0 = The Port pin is not configured as a Stop Mode Recovery source. Transitions on this pin during STOP mode do not initiate Stop Mode Recovery.

1 = The Port pin is configured as a Stop Mode Recovery source. Any logic transition on this pin during STOP mode initiates Stop Mode Recovery.

Port A–H Input Data Registers

Reading from the Port A–H Input Data registers (Table 21) returns the sampled values from the corresponding port pins. The Port A–H Input Data registers are Read-only.

Table 21. Port A–H Input Data Registers (PxIN)

BITS	7	6	5	4	3	2	1	0
FIELD	PIN7	PIN6	PIN5	PIN4	PIN3	PIN2	PIN1	PIN0
RESET	X							
R/W	R							
ADDR	FD2H, FD6H, FDAH, FDEH, FE2H, FE6H, FEAH, FEEH							

PIN[7:0]—Port Input Data
Sampled data from the corresponding port pin input.
0 = Input data is logical 0 (Low).
1 = Input data is logical 1 (High).

Port A–H Output Data Register

The Port A–H Output Data register (Table 22) writes output data to the pins.

Table 22. Port A–H Output Data Register (PxOUT)

BITS	7	6	5	4	3	2	1	0
FIELD	POUT7	POUT6	POUT5	POUT4	POUT3	POUT2	POUT1	POUT0
RESET	0							
R/W	R/W							
ADDR	FD3H, FD7H, FDBH, FDFH, FE3H, FE7H, FEBH, FEFH							

POUT[7:0]—Port Output Data
These bits contain the data to be driven out from the port pins. The values are only driven if the corresponding pin is configured as an output and the pin is not configured for alternate function operation.
0 = Drive a logical 0 (Low).
1 = Drive a logical 1 (High). High value is not driven if the drain has been disabled by setting the corresponding Port Output Control register bit to 1.

Interrupt Controller

Overview

The interrupt controller on the 64K Series products prioritizes the interrupt requests from the on-chip peripherals and the GPIO port pins. The features of the interrupt controller include the following:

- 24 unique interrupt vectors:
 - 12 GPIO port pin interrupt sources
 - 12 on-chip peripheral interrupt sources
- Flexible GPIO interrupts
 - Eight selectable rising and falling edge GPIO interrupts
 - Four dual-edge interrupts
- Three levels of individually programmable interrupt priority
- Watchdog Timer can be configured to generate an interrupt

Interrupt requests (IRQs) allow peripheral devices to suspend CPU operation in an orderly manner and force the CPU to start an interrupt service routine (ISR). Usually this interrupt service routine is involved with the exchange of data, status information, or control information between the CPU and the interrupting peripheral. When the service routine is completed, the CPU returns to the operation from which it was interrupted.

The eZ8 CPU supports both vectored and polled interrupt handling. For polled interrupts, the interrupt control has no effect on operation. For more information on interrupt servicing by the eZ8 CPU, refer to *eZ8[™] CPU Core User Manual (UM0128)* available for download at www.zilog.com.

Interrupt Vector Listing

[Table 23](#) lists all of the interrupts available in order of priority. The interrupt vector is stored with the most-significant byte (MSB) at the even Program Memory address and the least-significant byte (LSB) at the following odd Program Memory address.

Table 23. Interrupt Vectors in Order of Priority

Priority	Program Memory Vector Address	Interrupt Source
Highest	0002H	Reset (not an interrupt)
	0004H	Watchdog Timer (see Watchdog Timer on page 97)
	0006H	Illegal Instruction Trap (not an interrupt)
	0008H	Timer 2
	000AH	Timer 1
	000CH	Timer 0
	000EH	UART 0 receiver
	0010H	UART 0 transmitter
	0012H	I ² C
	0014H	SPI
	0016H	ADC
	0018H	Port A7 or Port D7, rising or falling input edge
	001AH	Port A6 or Port D6, rising or falling input edge
	001CH	Port A5 or Port D5, rising or falling input edge
	001EH	Port A4 or Port D4, rising or falling input edge
	0020H	Port A3 or Port D3, rising or falling input edge
	0022H	Port A2 or Port D2, rising or falling input edge
	0024H	Port A1 or Port D1, rising or falling input edge
	0026H	Port A0 or Port D0, rising or falling input edge
	0028H	Timer 3 (<i>not available in 44-pin packages</i>)
	002AH	UART 1 receiver
	002CH	UART 1 transmitter
	002EH	DMA
	0030H	Port C3, both input edges
	0032H	Port C2, both input edges
	0034H	Port C1, both input edges
Lowest	0036H	Port C0, both input edges

Architecture

Figure 11 displays a block diagram of the interrupt controller.

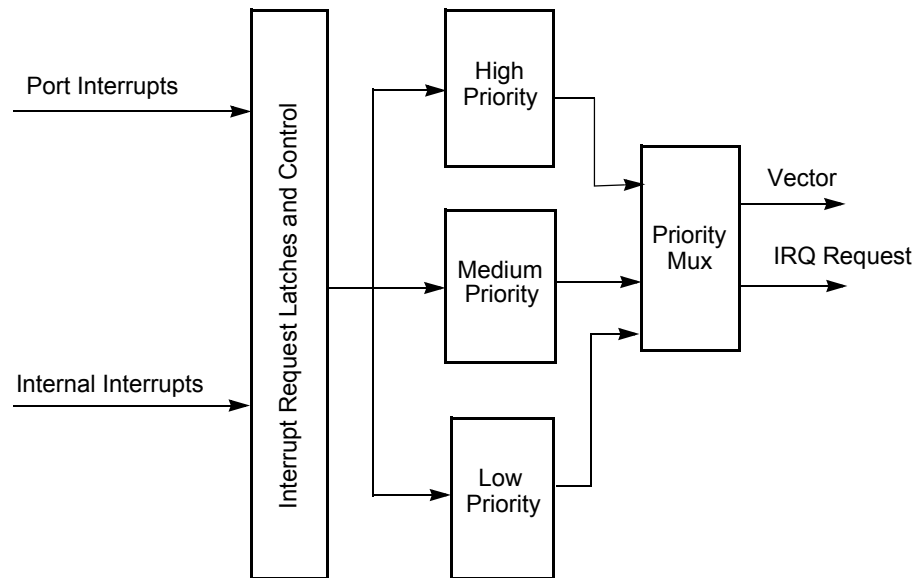

Figure 11. Interrupt Controller Block Diagram

Operation

Master Interrupt Enable

The master interrupt enable bit (IRQE) in the Interrupt Control register globally enables and disables interrupts.

Interrupts are globally enabled by any of the following actions:

- Executing an Enable Interrupt (EI) instruction.
- Executing an Return from Interrupt (IRET) instruction.
- Writing a 1 to the IRQE bit in the Interrupt Control register.

Interrupts are globally disabled by any of the following actions:

- Execution of a Disable Interrupt (DI) instruction.
- eZ8 CPU acknowledgement of an interrupt service request from the interrupt controller.
- Writing a 0 to the IRQE bit in the Interrupt Control register.
- Reset.

- Executing a Trap instruction.
- Illegal Instruction trap.

Interrupt Vectors and Priority

The interrupt controller supports three levels of interrupt priority. Level 3 is the highest priority, Level 2 is the second highest priority, and Level 1 is the lowest priority. If all of the interrupts were enabled with identical interrupt priority (all as Level 2 interrupts, for example), then interrupt priority would be assigned from highest to lowest as specified in [Table 23](#) on page 68. Level 3 interrupts always have higher priority than Level 2 interrupts which, in turn, always have higher priority than Level 1 interrupts. Within each interrupt priority level (Level 1, Level 2, or Level 3), priority is assigned as specified in [Table 23](#) on page 68. Reset, Watchdog Timer interrupt (if enabled), and Illegal Instruction Trap always have highest priority.

Interrupt Assertion

Interrupt sources assert their interrupt requests for only a single system clock period (single pulse). When the interrupt request is acknowledged by the eZ8 CPU, the corresponding bit in the Interrupt Request register is cleared until the next interrupt occurs. Writing a 0 to the corresponding bit in the Interrupt Request register likewise clears the interrupt request.



Caution: *The following style of coding to clear bits in the Interrupt Request registers is NOT recommended. All incoming interrupts that are received between execution of the first LDX command and the last LDX command are lost.*

Poor coding style that can result in lost interrupt requests:

```
LDX r0, IRQ0
AND r0, MASK
LDX IRQ0, r0
```

To avoid missing interrupts, the following style of coding to clear bits in the Interrupt Request 0 register is recommended:

Good coding style that avoids lost interrupt requests:

```
ANDX IRQ0, MASK
```

Software Interrupt Assertion

Program code can generate interrupts directly. Writing a 1 to the desired bit in the Interrupt Request register triggers an interrupt (assuming that interrupt is enabled). When the interrupt request is acknowledged by the eZ8 CPU, the bit in the Interrupt Request register is automatically cleared to 0.



Caution: *The following style of coding to generate software interrupts by setting bits in the Interrupt Request registers is NOT recommended. All incoming interrupts that are received between execution of the first LDX command and the last LDX command are lost.*

Poor coding style that can result in lost interrupt requests:

```
LDX r0, IRQ0
OR r0, MASK
LDX IRQ0, r0
```

To avoid missing interrupts, the following style of coding to set bits in the Interrupt Request registers is recommended:

Good coding style that avoids lost interrupt requests:

```
ORX IRQ0, MASK
```

Interrupt Control Register Definitions

For all interrupts other than the Watchdog Timer interrupt, the interrupt control registers enable individual interrupts, set interrupt priorities, and indicate interrupt requests.

Interrupt Request 0 Register

The Interrupt Request 0 (IRQ0) register ([Table 24](#)) stores the interrupt requests for both vectored and polled interrupts. When a request is presented to the interrupt controller, the corresponding bit in the IRQ0 register becomes 1. If interrupts are globally enabled (vectored interrupts), the interrupt controller passes an interrupt request to the eZ8[™] CPU. If interrupts are globally disabled (polled interrupts), the eZ8 CPU can read the Interrupt Request 0 register to determine if any interrupt requests are pending

Table 24. Interrupt Request 0 Register (IRQ0)

BITS	7	6	5	4	3	2	1	0
FIELD	T2I	T1I	T0I	U0RXI	U0TXI	I2CI	SPII	ADCI
RESET	0							
R/W	R/W							
ADDR	FC0H							

T2I—Timer 2 Interrupt Request

0 = No interrupt request is pending for Timer 2.

1 = An interrupt request from Timer 2 is awaiting service.

T1I—Timer 1 Interrupt Request

0 = No interrupt request is pending for Timer 1.

1 = An interrupt request from Timer 1 is awaiting service.

T0I—Timer 0 Interrupt Request

0 = No interrupt request is pending for Timer 0.

1 = An interrupt request from Timer 0 is awaiting service.

U0RXI—UART 0 Receiver Interrupt Request

0 = No interrupt request is pending for the UART 0 receiver.

1 = An interrupt request from the UART 0 receiver is awaiting service.

U0TXI—UART 0 Transmitter Interrupt Request

0 = No interrupt request is pending for the UART 0 transmitter.

1 = An interrupt request from the UART 0 transmitter is awaiting service.

I²CI— I²C Interrupt Request

0 = No interrupt request is pending for the I²C.

1 = An interrupt request from the I²C is awaiting service.

SPII—SPI Interrupt Request

0 = No interrupt request is pending for the SPI.

1 = An interrupt request from the SPI is awaiting service.

ADCI—ADC Interrupt Request

0 = No interrupt request is pending for the Analog-to-Digital Converter.

1 = An interrupt request from the Analog-to-Digital Converter is awaiting service.

Interrupt Request 1 Register

The Interrupt Request 1 (IRQ1) register ([Table 25](#)) stores interrupt requests for both vectored and polled interrupts. When a request is presented to the interrupt controller, the corresponding bit in the IRQ1 register becomes 1. If interrupts are globally enabled (vectored interrupts), the interrupt controller passes an interrupt request to the eZ8 CPU. If interrupts are globally disabled (polled interrupts), the eZ8 CPU can read the Interrupt Request 1 register to determine if any interrupt requests are pending.

Table 25. Interrupt Request 1 Register (IRQ1)

BITS	7	6	5	4	3	2	1	0
FIELD	PAD7I	PAD6I	PAD5I	PAD4I	PAD3I	PAD2I	PAD1I	PAD0I
RESET	0							
R/W	R/W							
ADDR	FC3H							

PADxI—Port A or Port D Pin *x* Interrupt Request

0 = No interrupt request is pending for GPIO Port A or Port D pin *x*.

1 = An interrupt request from GPIO Port A or Port D pin *x* is awaiting service.

where *x* indicates the specific GPIO Port pin number (0 through 7). For each pin, only 1 of either Port A or Port D can be enabled for interrupts at any one time. Port selection (A or D) is determined by the values in the Interrupt Port Select Register.

Interrupt Request 2 Register

The Interrupt Request 2 (IRQ2) register (Table 26) stores interrupt requests for both vectored and polled interrupts. When a request is presented to the interrupt controller, the corresponding bit in the IRQ2 register becomes 1. If interrupts are globally enabled (vectored interrupts), the interrupt controller passes an interrupt request to the eZ8 CPU. If interrupts are globally disabled (polled interrupts), the eZ8 CPU can read the Interrupt Request 1 register to determine if any interrupt requests are pending.

Table 26. Interrupt Request 2 Register (IRQ2)

BITS	7	6	5	4	3	2	1	0
FIELD	T3I	U1RXI	U1TXI	DMAI	PC3I	PC2I	PC1I	PC0I
RESET	0							
R/W	R/W							
ADDR	FC6H							

T3I—Timer 3 Interrupt Request

0 = No interrupt request is pending for Timer 3.

1 = An interrupt request from Timer 3 is awaiting service.

U1RXI—UART 1 Receive Interrupt Request

0 = No interrupt request is pending for the UART1 receiver.

1 = An interrupt request from UART1 receiver is awaiting service.

U1TXI—UART 1 Transmit Interrupt Request

0 = No interrupt request is pending for the UART 1 transmitter.

1 = An interrupt request from the UART 1 transmitter is awaiting service.

DMAI—DMA Interrupt Request

0 = No interrupt request is pending for the DMA.

1 = An interrupt request from the DMA is awaiting service.

PCxI—Port C Pin *x* Interrupt Request

0 = No interrupt request is pending for GPIO Port C pin *x*.

1 = An interrupt request from GPIO Port C pin *x* is awaiting service.

where x indicates the specific GPIO Port C pin number (0 through 3).

IRQ0 Enable High and Low Bit Registers

The IRQ0 Enable High and Low Bit registers (see [Table 28](#) and [Table 29](#) on page 75) form a priority encoded enabling for interrupts in the Interrupt Request 0 register. Priority is generated by setting bits in each register. [Table 27](#) describes the priority control for IRQ0.

Table 27. IRQ0 Enable and Priority Encoding

IRQ0ENH[x]	IRQ0ENL[x]	Priority	Description
0	0	Disabled	Disabled
0	1	Level 1	Low
1	0	Level 2	Nominal
1	1	Level 3	High

Note: where x indicates the register bits from 0 through 7.

Table 28. IRQ0 Enable High Bit Register (IRQ0ENH)

BITS	7	6	5	4	3	2	1	0
FIELD	T2ENH	T1ENH	T0ENH	U0RENH	U0TENH	I2CENH	SPIENH	ADCENH
RESET	0							
R/W	R/W							
ADDR	FC1H							

T2ENH—Timer 2 Interrupt Request Enable High Bit
 T1ENH—Timer 1 Interrupt Request Enable High Bit
 T0ENH—Timer 0 Interrupt Request Enable High Bit
 U0RENH—UART 0 Receive Interrupt Request Enable High Bit
 U0TENH—UART 0 Transmit Interrupt Request Enable High Bit
 I2CENH—I²C Interrupt Request Enable High Bit
 SPIENH—SPI Interrupt Request Enable High Bit
 ADCENH—ADC Interrupt Request Enable High Bit

Table 29. IRQ0 Enable Low Bit Register (IRQ0ENL)

BITS	7	6	5	4	3	2	1	0
FIELD	T2ENL	T1ENL	T0ENL	U0RENL	U0TENL	I2CENL	SPIENL	ADCENL
RESET	0							
R/W	R/W							
ADDR	FC2H							

T2ENL—Timer 2 Interrupt Request Enable Low Bit
T1ENL—Timer 1 Interrupt Request Enable Low Bit
T0ENL—Timer 0 Interrupt Request Enable Low Bit
U0RENL—UART 0 Receive Interrupt Request Enable Low Bit
U0TENL—UART 0 Transmit Interrupt Request Enable Low Bit
I2CENL—I²C Interrupt Request Enable Low Bit
SPIENL—SPI Interrupt Request Enable Low Bit
ADCENL—ADC Interrupt Request Enable Low Bit

IRQ1 Enable High and Low Bit Registers

The IRQ1 Enable High and Low Bit registers (see [Table 31](#) and [Table 32](#) on page 76) form a priority encoded enabling for interrupts in the Interrupt Request 1 register. Priority is generated by setting bits in each register. [Table 30](#) describes the priority control for IRQ1.

Table 30. IRQ1 Enable and Priority Encoding

IRQ1ENH[x]	IRQ1ENL[x]	Priority	Description
0	0	Disabled	Disabled
0	1	Level 1	Low
1	0	Level 2	Nominal
1	1	Level 3	High

Note: where x indicates the register bits from 0 through 7.

Table 31. IRQ1 Enable High Bit Register (IRQ1ENH)

BITS	7	6	5	4	3	2	1	0
FIELD	PAD7ENH	PAD6ENH	PAD5ENH	PAD4ENH	PAD3ENH	PAD2ENH	PAD1ENH	PAD0ENH
RESET	0	0	0	0	0	0	0	0
R/W	R/W	R/W	R/W	R/W	R/W	R/W	R/W	R/W
ADDR	FC4H							

PADxENH—Port A or Port D Bit[x] Interrupt Request Enable High Bit.
For selection of either Port A or Port D as the interrupt source, see [Interrupt Port Select Register](#) on page 78.

Table 32. IRQ1 Enable Low Bit Register (IRQ1ENL)

BITS	7	6	5	4	3	2	1	0
FIELD	PAD7ENL	PAD6ENL	PAD5ENL	PAD4ENL	PAD3ENL	PAD2ENL	PAD1ENL	PAD0ENL
RESET	0	0	0	0	0	0	0	0
R/W	R/W	R/W	R/W	R/W	R/W	R/W	R/W	R/W
ADDR	FC5H							

PADxENL—Port A or Port D Bit[x] Interrupt Request Enable Low Bit
For selection of either Port A or Port D as the interrupt source, see [Interrupt Port Select Register](#) on page 78.

IRQ2 Enable High and Low Bit Registers

The IRQ2 Enable High and Low Bit registers (see [Table 34](#) and [Table 35](#) on page 77) form a priority encoded enabling for interrupts in the Interrupt Request 2 register. Priority is generated by setting bits in each register. [Table 33](#) describes the priority control for IRQ2.

Table 33. IRQ2 Enable and Priority Encoding

IRQ2ENH[x]	IRQ2ENL[x]	Priority	Description
0	0	Disabled	Disabled
0	1	Level 1	Low
1	0	Level 2	Nominal

Table 33. IRQ2 Enable and Priority Encoding (Continued)

IRQ2ENH[x]	IRQ2ENL[x]	Priority	Description
1	1	Level 3	High

Note: where x indicates the register bits from 0 through 7.

Table 34. IRQ2 Enable High Bit Register (IRQ2ENH)

BITS	7	6	5	4	3	2	1	0
FIELD	T3ENH	U1RENH	U1TENH	DMAENH	C3ENH	C2ENH	C1ENH	C0ENH
RESET	0							
R/W	R/W							
ADDR	FC7H							

T3ENH—Timer 3 Interrupt Request Enable High Bit
 U1RENH—UART 1 Receive Interrupt Request Enable High Bit
 U1TENH—UART 1 Transmit Interrupt Request Enable High Bit
 DMAENH—DMA Interrupt Request Enable High Bit
 C3ENH—Port C3 Interrupt Request Enable High Bit
 C2ENH—Port C2 Interrupt Request Enable High Bit
 C1ENH—Port C1 Interrupt Request Enable High Bit
 C0ENH—Port C0 Interrupt Request Enable High Bit

Table 35. IRQ2 Enable Low Bit Register (IRQ2ENL)

BITS	7	6	5	4	3	2	1	0
FIELD	T3ENL	U1RENL	U1TENL	DMAENL	C3ENL	C2ENL	C1ENL	C0ENL
RESET	0							
R/W	R/W							
ADDR	FC8H							

T3ENL—Timer 3 Interrupt Request Enable Low Bit
 U1RENL—UART 1 Receive Interrupt Request Enable Low Bit
 U1TENL—UART 1 Transmit Interrupt Request Enable Low Bit
 DMAENL—DMA Interrupt Request Enable Low Bit
 C3ENL—Port C3 Interrupt Request Enable Low Bit
 C2ENL—Port C2 Interrupt Request Enable Low Bit

C1ENL—Port C1 Interrupt Request Enable Low Bit

C0ENL—Port C0 Interrupt Request Enable Low Bit

Interrupt Edge Select Register

The Interrupt Edge Select (IRQES) register (Table 36) determines whether an interrupt is generated for the rising edge or falling edge on the selected GPIO Port input pin. The Interrupt Port Select register selects between Port A and Port D for the individual interrupts.

Table 36. Interrupt Edge Select Register (IRQES)

BITS	7	6	5	4	3	2	1	0
FIELD	IES7	IES6	IES5	IES4	IES3	IES2	IES1	IES0
RESET	0							
R/W	R/W							
ADDR	FCDH							

IES_x—Interrupt Edge Select *x*

The minimum pulse width should be greater than 1 system clock to guarantee capture of the edge triggered interrupt. Shorter pulses may be captured but not guaranteed.

0 = An interrupt request is generated on the falling edge of the PAX/PD_x input.

1 = An interrupt request is generated on the rising edge of the PAX/PD_x input.

where *x* indicates the specific GPIO Port pin number (0 through 7).

Interrupt Port Select Register

The Port Select (IRQPS) register (Table 37) determines the port pin that generates the PAX/PD_x interrupts. This register allows either Port A or Port D pins to be used as interrupts. The Interrupt Edge Select register controls the active interrupt edge.

Table 37. Interrupt Port Select Register (IRQPS)

BITS	7	6	5	4	3	2	1	0
FIELD	PAD7S	PAD6S	PAD5S	PAD4S	PAD3S	PAD2S	PAD1S	PAD0S
RESET	0							
R/W	R/W							
ADDR	FCEH							

PADxS—PAx/PDx Selection

0 = PAx is used for the interrupt for PAx/PDx interrupt request.

1 = PDx is used for the interrupt for PAx/PDx interrupt request.

where *x* indicates the specific GPIO Port pin number (0 through 7).

Interrupt Control Register

The Interrupt Control (IRQCTL) register (Table 38) contains the master enable bit for all interrupts.

Table 38. Interrupt Control Register (IRQCTL)

BITS	7	6	5	4	3	2	1	0
FIELD	IRQE	Reserved						
RESET	0							
R/W	R/W	R						
ADDR	FCFH							

IRQE—Interrupt Request Enable

This bit is set to 1 by execution of an EI or IRET instruction, or by a direct register write of a 1 to this bit. It is reset to 0 by executing a DI instruction, eZ8 CPU acknowledgement of an interrupt request, or Reset.

0 = Interrupts are disabled

1 = Interrupts are enabled

Reserved—Must be 0.



Timers

Overview

The 64K Series products contain up to four 16-bit reloadable timers that can be used for timing, event counting, or generation of pulse width modulated signals. The timers' features include:

- 16-bit reload counter
- Programmable prescaler with prescale values from 1 to 128
- PWM output generation
- Capture and compare capability
- External input pin for timer input, clock gating, or capture signal. External input pin signal frequency is limited to a maximum of one-fourth the system clock frequency.
- Timer output pin
- Timer interrupt

In addition to the timers described in this chapter, the Baud Rate Generators for any unused UART, SPI, or I²C peripherals may also be used to provide basic timing functionality. For information on using the Baud Rate Generators as timers, see the respective serial communication peripheral. Timer 3 is unavailable in the 44-pin package devices.

Architecture

[Figure 12](#) displays the architecture of the timers.

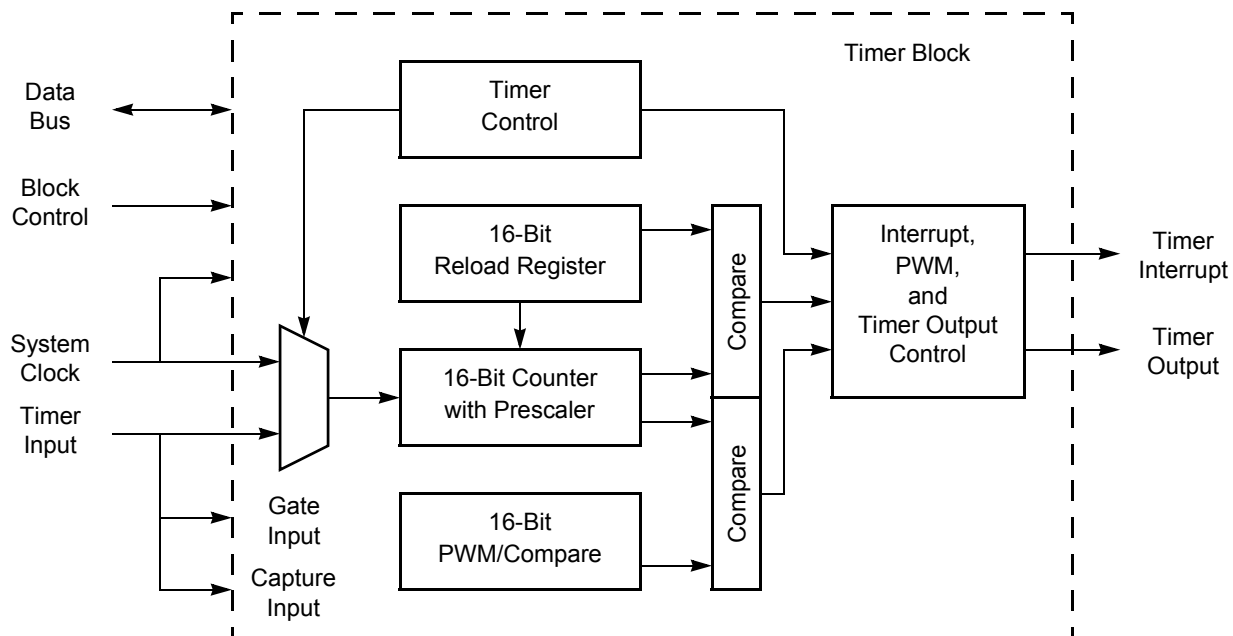

Figure 12. Timer Block Diagram

Operation

The timers are 16-bit up-counters. Minimum time-out delay is set by loading the value 0001H into the Timer Reload High and Low Byte registers and setting the prescale value to 1. Maximum time-out delay is set by loading the value 0000H into the Timer Reload High and Low Byte registers and setting the prescale value to 128. If the Timer reaches FFFFH, the timer rolls over to 0000H and continues counting.

Timer Operating Modes

The timers can be configured to operate in the following modes:

ONE-SHOT Mode

In ONE-SHOT mode, the timer counts up to the 16-bit Reload value stored in the Timer Reload High and Low Byte registers. The timer input is the system clock. Upon reaching the Reload value, the timer generates an interrupt and the count value in the Timer High and Low Byte registers is reset to 0001H. Then, the timer is automatically disabled and stops counting.

Also, if the Timer Output alternate function is enabled, the Timer Output pin changes state for one system clock cycle (from Low to High or from High to Low) upon timer Reload. If it is desired to have the Timer Output make a permanent state change upon

One-Shot time-out, first set the TPOL bit in the Timer Control 1 Register to the start value before beginning ONE-SHOT mode. Then, after starting the timer, set TPOL to the opposite bit value.

Follow the steps below for configuring a timer for ONE-SHOT mode and initiating the count:

1. Write to the Timer Control 1 register to:
 - Disable the timer
 - Configure the timer for ONE-SHOT mode
 - Set the prescale value
 - If using the Timer Output alternate function, set the initial output level (High or Low)
2. Write to the Timer High and Low Byte registers to set the starting count value
3. Write to the Timer Reload High and Low Byte registers to set the Reload value
4. If desired, enable the timer interrupt and set the timer interrupt priority by writing to the relevant interrupt registers
5. If using the Timer Output function, configure the associated GPIO port pin for the Timer Output alternate function
6. Write to the Timer Control 1 register to enable the timer and initiate counting

In ONE-SHOT mode, the system clock always provides the timer input. The timer period is given by the following equation:

$$\text{ONE-SHOT Mode Time-Out Period (s)} = \frac{(\text{Reload Value} - \text{Start Value}) \times \text{Prescale}}{\text{System Clock Frequency (Hz)}}$$

CONTINUOUS Mode

In CONTINUOUS mode, the timer counts up to the 16-bit Reload value stored in the Timer Reload High and Low Byte registers. The timer input is the system clock. Upon reaching the Reload value, the timer generates an interrupt, the count value in the Timer High and Low Byte registers is reset to 0001H and counting resumes. Also, if the Timer Output alternate function is enabled, the Timer Output pin changes state (from Low to High or from High to Low) upon timer Reload.

Follow the steps below for configuring a timer for CONTINUOUS mode and initiating the count:

1. Write to the Timer Control 1 register to:
 - Disable the timer
 - Configure the timer for CONTINUOUS mode
 - Set the prescale value
 - If using the Timer Output alternate function, set the initial output level (High or Low)

2. Write to the Timer High and Low Byte registers to set the starting count value (usually 0001H), affecting only the first pass in CONTINUOUS mode. After the first timer Reload in CONTINUOUS mode, counting always begins at the reset value of 0001H.
3. Write to the Timer Reload High and Low Byte registers to set the Reload value.
4. If desired, enable the timer interrupt and set the timer interrupt priority by writing to the relevant interrupt registers.
5. If using the Timer Output function, configure the associated GPIO port pin for the Timer Output alternate function.
6. Write to the Timer Control 1 register to enable the timer and initiate counting.

In CONTINUOUS mode, the system clock always provides the timer input. The timer period is given by the following equation:

$$\text{CONTINUOUS Mode Time-Out Period (s)} = \frac{\text{Reload Value} \times \text{Prescale}}{\text{System Clock Frequency (Hz)}}$$

If an initial starting value other than 0001H is loaded into the Timer High and Low Byte registers, the ONE-SHOT mode equation must be used to determine the first time-out period.

COUNTER Mode

In COUNTER mode, the timer counts input transitions from a GPIO port pin. The timer input is taken from the GPIO Port pin Timer Input alternate function. The TPOL bit in the Timer Control 1 Register selects whether the count occurs on the rising edge or the falling edge of the Timer Input signal. In COUNTER mode, the prescaler is disabled.



Caution: *The input frequency of the Timer Input signal must not exceed one-fourth the system clock frequency.*

Upon reaching the Reload value stored in the Timer Reload High and Low Byte registers, the timer generates an interrupt, the count value in the Timer High and Low Byte registers is reset to 0001H and counting resumes. Also, if the Timer Output alternate function is enabled, the Timer Output pin changes state (from Low to High or from High to Low) at timer Reload.

Follow the steps below for configuring a timer for COUNTER mode and initiating the count:

1. Write to the Timer Control 1 register to:
 - Disable the timer
 - Configure the timer for COUNTER mode

- Select either the rising edge or falling edge of the Timer Input signal for the count. This also sets the initial logic level (High or Low) for the Timer Output alternate function. However, the Timer Output function does not have to be enabled
- 2. Write to the Timer High and Low Byte registers to set the starting count value. This only affects the first pass in COUNTER mode. After the first timer Reload in COUNTER mode, counting always begins at the reset value of 0001H. Generally, in COUNTER mode the Timer High and Low Byte registers must be written with the value 0001H.
- 3. Write to the Timer Reload High and Low Byte registers to set the Reload value.
- 4. If desired, enable the timer interrupt and set the timer interrupt priority by writing to the relevant interrupt registers.
- 5. Configure the associated GPIO port pin for the Timer Input alternate function.
- 6. If using the Timer Output function, configure the associated GPIO port pin for the Timer Output alternate function.
- 7. Write to the Timer Control 1 register to enable the timer.

In COUNTER mode, the number of Timer Input transitions since the timer start is given by the following equation:

$$\text{COUNTER Mode Timer Input Transitions} = \text{Current Count Value} - \text{Start Value}$$

PWM Mode

In PWM mode, the timer outputs a Pulse-Width Modulator (PWM) output signal through a GPIO Port pin. The timer input is the system clock. The timer first counts up to the 16-bit PWM match value stored in the Timer PWM High and Low Byte registers. When the timer count value matches the PWM value, the Timer Output toggles. The timer continues counting until it reaches the Reload value stored in the Timer Reload High and Low Byte registers. Upon reaching the Reload value, the timer generates an interrupt, the count value in the Timer High and Low Byte registers is reset to 0001H and counting resumes.

If the TPOL bit in the Timer Control 1 register is set to 1, the Timer Output signal begins as a High (1) and then transitions to a Low (0) when the timer value matches the PWM value. The Timer Output signal returns to a High (1) after the timer reaches the Reload value and is reset to 0001H.

If the TPOL bit in the Timer Control 1 register is set to 0, the Timer Output signal begins as a Low (0) and then transitions to a High (1) when the timer value matches the PWM value. The Timer Output signal returns to a Low (0) after the timer reaches the Reload value and is reset to 0001H.

Follow the steps below for configuring a timer for PWM mode and initiating the PWM operation:

1. Write to the Timer Control 1 register to:
 - Disable the timer
 - Configure the timer for PWM mode
 - Set the prescale value
 - Set the initial logic level (High or Low) and PWM High/Low transition for the Timer Output alternate function
2. Write to the Timer High and Low Byte registers to set the starting count value (typically 0001H). This only affects the first pass in PWM mode. After the first timer reset in PWM mode, counting always begins at the reset value of 0001H.
3. Write to the PWM High and Low Byte registers to set the PWM value.
4. Write to the Timer Reload High and Low Byte registers to set the Reload value (PWM period). The Reload value must be greater than the PWM value.
5. If desired, enable the timer interrupt and set the timer interrupt priority by writing to the relevant interrupt registers.
6. Configure the associated GPIO port pin for the Timer Output alternate function.
7. Write to the Timer Control 1 register to enable the timer and initiate counting.

The PWM period is given by the following equation:

$$\text{PWM Period (s)} = \frac{\text{Reload Value} \times \text{Prescale}}{\text{System Clock Frequency (Hz)}}$$

If an initial starting value other than 0001H is loaded into the Timer High and Low Byte registers, the ONE-SHOT mode equation must be used to determine the first PWM time-out period.

If TPOL is set to 0, the ratio of the PWM output High time to the total period is given by:

$$\text{PWM Output High Time Ratio (\%)} = \frac{\text{Reload Value} - \text{PWM Value}}{\text{Reload Value}} \times 100$$

If TPOL is set to 1, the ratio of the PWM output High time to the total period is given by:

$$\text{PWM Output High Time Ratio (\%)} = \frac{\text{PWM Value}}{\text{Reload Value}} \times 100$$

CAPTURE Mode

In CAPTURE mode, the current timer count value is recorded when the desired external Timer Input transition occurs. The Capture count value is written to the Timer PWM High and Low Byte Registers. The timer input is the system clock. The TPOL bit in the Timer Control 1 register determines if the Capture occurs on a rising edge or a falling edge of the Timer Input signal. When the Capture event occurs, an interrupt is generated and the timer continues counting.

The timer continues counting up to the 16-bit Reload value stored in the Timer Reload High and Low Byte registers. Upon reaching the Reload value, the timer generates an interrupt and continues counting.

Follow the steps below for configuring a timer for CAPTURE mode and initiating the count:

1. Write to the Timer Control 1 register to:
 - Disable the timer
 - Configure the timer for CAPTURE mode.
 - Set the prescale value.
 - Set the Capture edge (rising or falling) for the Timer Input.
2. Write to the Timer High and Low Byte registers to set the starting count value (typically 0001H).
3. Write to the Timer Reload High and Low Byte registers to set the Reload value.
4. Clear the Timer PWM High and Low Byte registers to 0000H. This allows the software to determine if interrupts were generated by either a capture event or a reload. If the PWM High and Low Byte registers still contain 0000H after the interrupt, then the interrupt was generated by a Reload.
5. If desired, enable the timer interrupt and set the timer interrupt priority by writing to the relevant interrupt registers.
6. Configure the associated GPIO port pin for the Timer Input alternate function.
7. Write to the Timer Control 1 register to enable the timer and initiate counting.

In CAPTURE mode, the elapsed time from timer start to Capture event can be calculated using the following equation:

$$\text{Capture Elapsed Time (s)} = \frac{(\text{Capture Value} - \text{Start Value}) \times \text{Prescale}}{\text{System Clock Frequency (Hz)}}$$

COMPARE Mode

In COMPARE mode, the timer counts up to the 16-bit maximum Compare value stored in the Timer Reload High and Low Byte registers. The timer input is the system clock. Upon reaching the Compare value, the timer generates an interrupt and counting continues (the timer value is not reset to 0001H). Also, if the Timer Output alternate function is enabled, the Timer Output pin changes state (from Low to High or from High to Low) upon Compare.

If the Timer reaches FFFFH, the timer rolls over to 0000H and continue counting.

Follow the steps below for configuring a timer for COMPARE mode and initiating the count:

1. Write to the Timer Control 1 register to:
 - Disable the timer
 - Configure the timer for COMPARE mode
 - Set the prescale value
 - Set the initial logic level (High or Low) for the Timer Output alternate function, if desired
2. Write to the Timer High and Low Byte registers to set the starting count value.
3. Write to the Timer Reload High and Low Byte registers to set the Compare value.
4. If desired, enable the timer interrupt and set the timer interrupt priority by writing to the relevant interrupt registers.
5. If using the Timer Output function, configure the associated GPIO port pin for the Timer Output alternate function.
6. Write to the Timer Control 1 register to enable the timer and initiate counting.

In COMPARE mode, the system clock always provides the timer input. The Compare time is given by the following equation:

$$\text{COMPARE Mode Time (s)} = \frac{(\text{Compare Value} - \text{Start Value}) \times \text{Prescale}}{\text{System Clock Frequency (Hz)}}$$

GATED Mode

In GATED mode, the timer counts only when the Timer Input signal is in its active state (asserted), as determined by the TPOL bit in the Timer Control 1 register. When the Timer Input signal is asserted, counting begins. A timer interrupt is generated when the Timer Input signal is deasserted or a timer reload occurs. To determine if a Timer Input signal deassertion generated the interrupt, read the associated GPIO input value and compare to the value stored in the TPOL bit.

The timer counts up to the 16-bit Reload value stored in the Timer Reload High and Low Byte registers. The timer input is the system clock. When reaching the Reload value, the timer generates an interrupt, the count value in the Timer High and Low Byte registers is reset to 0001H and counting resumes (assuming the Timer Input signal is still asserted). Also, if the Timer Output alternate function is enabled, the Timer Output pin changes state (from Low to High or from High to Low) at timer reset.

Follow the steps below for configuring a timer for GATED mode and initiating the count:

1. Write to the Timer Control 1 register to:
 - Disable the timer
 - Configure the timer for GATED mode

- Set the prescale value
- 2. Write to the Timer High and Low Byte registers to set the starting count value. This only affects the first pass in GATED mode. After the first timer reset in GATED mode, counting always begins at the reset value of 0001H.
- 3. Write to the Timer Reload High and Low Byte registers to set the Reload value.
- 4. If desired, enable the timer interrupt and set the timer interrupt priority by writing to the relevant interrupt registers.
- 5. Configure the associated GPIO port pin for the Timer Input alternate function.
- 6. Write to the Timer Control 1 register to enable the timer.
- 7. Assert the Timer Input signal to initiate the counting.

CAPTURE/COMPARE Mode

In CAPTURE/COMPARE mode, the timer begins counting on the *first* external Timer Input transition. The desired transition (rising edge or falling edge) is set by the TPOL bit in the Timer Control 1 Register. The timer input is the system clock.

Every subsequent desired transition (after the first) of the Timer Input signal captures the current count value. The Capture value is written to the Timer PWM High and Low Byte Registers. When the Capture event occurs, an interrupt is generated, the count value in the Timer High and Low Byte registers is reset to 0001H, and counting resumes.

If no Capture event occurs, the timer counts up to the 16-bit Compare value stored in the Timer Reload High and Low Byte registers. Upon reaching the Compare value, the timer generates an interrupt, the count value in the Timer High and Low Byte registers is reset to 0001H and counting resumes.

Follow the steps below for configuring a timer for CAPTURE/COMPARE mode and initiating the count:

1. Write to the Timer Control 1 register to:
 - Disable the timer
 - Configure the timer for CAPTURE/COMPARE mode
 - Set the prescale value
 - Set the Capture edge (rising or falling) for the Timer Input
2. Write to the Timer High and Low Byte registers to set the starting count value (typically 0001H).
3. Write to the Timer Reload High and Low Byte registers to set the Compare value.
4. If desired, enable the timer interrupt and set the timer interrupt priority by writing to the relevant interrupt registers.
5. Configure the associated GPIO port pin for the Timer Input alternate function.

6. Write to the Timer Control 1 register to enable the timer.
7. Counting begins on the first appropriate transition of the Timer Input signal. No interrupt is generated by this first edge.

In m/COMPARE mode, the elapsed time from timer start to Capture event can be calculated using the following equation:

$$\text{Capture Elapsed Time (s)} = \frac{(\text{Capture Value} - \text{Start Value}) \times \text{Prescale}}{\text{System Clock Frequency (Hz)}}$$

Reading the Timer Count Values

The current count value in the timers can be read while counting (enabled). This capability has no effect on timer operation. When the timer is enabled and the Timer High Byte register is read, the contents of the Timer Low Byte register are placed in a holding register. A subsequent read from the Timer Low Byte register returns the value in the holding register. This operation allows accurate reads of the full 16-bit timer count value while enabled. When the timers are not enabled, a read from the Timer Low Byte register returns the actual value in the counter.

Timer Output Signal Operation

Timer Output is a GPIO Port pin alternate function. Generally, the Timer Output is toggled every time the counter is reloaded.

Timer Control Register Definitions

Timers 0-2 are available in all packages. Timer 3 is only available in the 64-, 68-, and 80-pin packages.

Timer 0-3 High and Low Byte Registers

The Timer 0-3 High and Low Byte (TxH and TxL) registers (see [Table 39](#) and [Table 40](#) on page 91) contain the current 16-bit timer count value. When the timer is enabled, a read from TxH causes the value in TxL to be stored in a temporary holding register. A read from TMRL always returns this temporary register when the timers are enabled. When the timer is disabled, reads from the TMRL reads the register directly.

Writing to the Timer High and Low Byte registers while the timer is enabled is not recommended. There are no temporary holding registers available for write operations, so simultaneous 16-bit writes are not possible. If either the Timer High or Low Byte registers are written during counting, the 8-bit written value is placed in the counter (High or Low Byte) at the next clock edge. The counter continues counting from the new value.

Timer 3 is unavailable in the 40- and 44-pin packages.

Table 39. Timer 0-3 High Byte Register (TxH)

BITS	7	6	5	4	3	2	1	0
FIELD	TH							
RESET	0							
R/W	R/W							
ADDR	F00H, F08H, F10H, F18H							

Table 40. Timer 0-3 Low Byte Register (TxL)

BITS	7	6	5	4	3	2	1	0
FIELD	TL							
RESET	0							1
R/W	R/W							
ADDR	F01H, F09H, F11H, F19H							

TH and TL—Timer High and Low Bytes

These 2 bytes, {TMRH[7:0], TMRL[7:0]}, contain the current 16-bit timer count value.

Timer Reload High and Low Byte Registers

The Timer 0-3 Reload High and Low Byte (TxRH and TxRL) registers (see [Table 41](#) and [Table 42](#) on page 92) store a 16-bit reload value, {TRH[7:0], TRL[7:0]}. Values written to the Timer Reload High Byte register are stored in a temporary holding register. When a write to the Timer Reload Low Byte register occurs, the temporary holding register value is written to the Timer High Byte register. This operation allows simultaneous updates of the 16-bit Timer Reload value.

In COMPARE mode, the Timer Reload High and Low Byte registers store the 16-bit Compare value.

Table 41. Timer 0-3 Reload High Byte Register (TxRH)

BITS	7	6	5	4	3	2	1	0
FIELD	TRH							
RESET	1							
R/W	R/W							
ADDR	F02H, F0AH, F12H, F1AH							

Table 42. Timer 0-3 Reload Low Byte Register (TxRL)

BITS	7	6	5	4	3	2	1	0
FIELD	TRL							
RESET	1							
R/W	R/W							
ADDR	F03H, F0BH, F13H, F1BH							

TRH and TRL—Timer Reload Register High and Low

These two bytes form the 16-bit Reload value, {TRH[7:0], TRL[7:0]}. This value sets the maximum count value which initiates a timer reload to 0001H. In COMPARE mode, these two bytes form the 16-bit Compare value.

Timer 0-3 PWM High and Low Byte Registers

The Timer 0-3 PWM High and Low Byte (TxPWMH and TxPWML) registers (see [Table 43](#) and [Table 44](#) on page 92) are used for Pulse-Width Modulator (PWM) operations. These registers also store the Capture values for the Capture and Capture/COMPARE modes.

Table 43. Timer 0-3 PWM High Byte Register (TxPWMH)

BITS	7	6	5	4	3	2	1	0
FIELD	PWMH							
RESET	0							
R/W	R/W							
ADDR	F04H, F0CH, F14H, F1CH							

Table 44. Timer 0-3 PWM Low Byte Register (TxPWML)

BITS	7	6	5	4	3	2	1	0
FIELD	PWML							
RESET	0							
R/W	R/W							
ADDR	F05H, F0DH, F15H, F1DH							



PWMH and PWML—Pulse-Width Modulator High and Low Bytes

These two bytes, {PWMH[7:0], PWML[7:0]}, form a 16-bit value that is compared to the current 16-bit timer count. When a match occurs, the PWM output changes state. The PWM output value is set by the TPOL bit in the Timer Control 1 Register (TxCTL1) register.

The TxPWMH and TxPWML registers also store the 16-bit captured timer value when operating in CAPTURE or CAPTURE/COMPARE modes.

Timer 0-3 Control 0 Registers

The Timer 0-3 Control 0 (TxCTL0) registers (see [Table 45](#) and [Table 46](#)) allow cascading of the Timers.

Table 45. Timer 0-3 Control 0 Register (TxCTL0)

BITS	7	6	5	4	3	2	1	0
FIELD	Reserved			CSC	Reserved			
RESET	0							
R/W	R/W							
ADDR	F06H, F0EH, F16H, F1EH							

CSC—Cascade Timers

0 = Timer Input signal comes from the pin.

1 = For Timer 0, Input signal is connected to Timer 3 output.

For Timer 1, Input signal is connected to Timer 0 output.

For Timer 2, Input signal is connected to Timer 1 output.

For Timer 3, Input signal is connected to Timer 2 output.

Timer 0-3 Control 1 Registers

The Timer 0-3 Control 1 (TxCTL1) registers enable/disable the timers, set the prescaler value, and determine the timer operating mode.

Table 46. Timer 0-3 Control 1 Register (TxCTL1)

BITS	7	6	5	4	3	2	1	0
FIELD	TEN	TPOL	PRES			TMODE		
RESET	0							
R/W	R/W							
ADDR	F07H, F0FH, F17H, F1FH							

TEN—Timer Enable

0 = Timer is disabled.

1 = Timer enabled to count.

TPOL—Timer Input/Output Polarity

Operation of this bit is a function of the current operating mode of the timer.

ONE-SHOT mode

When the timer is disabled, the Timer Output signal is set to the value of this bit. When the timer is enabled, the Timer Output signal is complemented upon timer Reload.

CONTINUOUS mode

When the timer is disabled, the Timer Output signal is set to the value of this bit. When the timer is enabled, the Timer Output signal is complemented upon timer Reload.

COUNTER mode

When the timer is disabled, the Timer Output signal is set to the value of this bit. When the timer is enabled, the Timer Output signal is complemented upon timer Reload.

0 = Count occurs on the rising edge of the Timer Input signal.

1 = Count occurs on the falling edge of the Timer Input signal.

PWM mode

0 = Timer Output is forced Low (0) when the timer is disabled. When enabled, the Timer Output is forced High (1) upon PWM count match and forced Low (0) upon Reload.

1 = Timer Output is forced High (1) when the timer is disabled. When enabled, the Timer Output is forced Low (0) upon PWM count match and forced High (1) upon Reload.

CAPTURE mode

0 = Count is captured on the rising edge of the Timer Input signal.
1 = Count is captured on the falling edge of the Timer Input signal.

COMPARE mode

When the timer is disabled, the Timer Output signal is set to the value of this bit. When the timer is enabled, the Timer Output signal is complemented upon timer Reload.

GATED mode

0 = Timer counts when the Timer Input signal is High (1) and interrupts are generated on the falling edge of the Timer Input.
1 = Timer counts when the Timer Input signal is Low (0) and interrupts are generated on the rising edge of the Timer Input.

CAPTURE/COMPARE mode

0 = Counting is started on the first rising edge of the Timer Input signal. The current count is captured on subsequent rising edges of the Timer Input signal.
1 = Counting is started on the first falling edge of the Timer Input signal. The current count is captured on subsequent falling edges of the Timer Input signal.



Caution: *When the Timer Output alternate function TxOUT on a GPIO port pin is enabled, TxOUT will change to whatever state the TPOL bit is in. The timer does not need to be enabled for that to happen. Also, the Port data direction sub register is not needed to be set to output on TxOUT. Changing the TPOL bit with the timer enabled and running does not immediately change the TxOUT.*

PRES—Prescale value.

The timer input clock is divided by 2^{PRES} , where PRES can be set from 0 to 7. The prescaler is reset each time the Timer is disabled. This insures proper clock division each time the Timer is restarted.

000 = Divide by 1
001 = Divide by 2
010 = Divide by 4
011 = Divide by 8
100 = Divide by 16
101 = Divide by 32

110 = Divide by 64

111 = Divide by 128

TMODE—TIMER mode

000 = ONE-SHOT mode

001 = CONTINUOUS mode

010 = COUNTER mode

011 = PWM mode

100 = CAPTURE mode

101 = COMPARE mode

110 = GATED mode

111 = CAPTURE/COMPARE mode

Watchdog Timer

Overview

The Watchdog Timer (WDT) helps protect against corrupt or unreliable software, power faults, and other system-level problems which may place the Z8 Encore! XP into unsuitable operating states. The features of Watchdog Timer include:

- On-chip RC oscillator.
- A selectable time-out response.
- WDT Time-out response: Reset or interrupt.
- 24-bit programmable time-out value.

Operation

The Watchdog Timer (WDT) is a retriggerable one-shot timer that resets or interrupts the 64K Series devices when the WDT reaches its terminal count. The Watchdog Timer uses its own dedicated on-chip RC oscillator as its clock source. The Watchdog Timer has only two modes of operation—ON and OFF. Once enabled, it always counts and must be refreshed to prevent a time-out. An enable can be performed by executing the WDT instruction or by setting the WDT_AO Option Bit. The WDT_AO bit enables the Watchdog Timer to operate all the time, even if a WDT instruction has not been executed.

The Watchdog Timer is a 24-bit reloadable downcounter that uses three 8-bit registers in the eZ8[™] CPU register space to set the reload value. The nominal WDT time-out period is given by the following equation:

$$\text{WDT Time-out Period (ms)} = \frac{\text{WDT Reload Value}}{10}$$

where the WDT reload value is the decimal value of the 24-bit value given by {WDTU[7:0], WDTM[7:0], WDTL[7:0]} and the typical Watchdog Timer RC oscillator frequency is 10 kHz. The Watchdog Timer cannot be refreshed once it reaches 000002H. The WDT Reload Value must not be set to values below 000004H. [Table 47](#) provides information on approximate time-out delays for the minimum and maximum WDT reload values.

Table 47. Watchdog Timer Approximate Time-Out Delays

WDT Reload Value (Hex)	WDT Reload Value (Decimal)	Approximate Time-Out Delay (with 10 kHz typical WDT oscillator frequency)	
		Typical	Description
000004	4	400 μ s	Minimum time-out delay
FFFFFF	16,777,215	1677.5 s	Maximum time-out delay

Watchdog Timer Refresh

When first enabled, the Watchdog Timer is loaded with the value in the Watchdog Timer Reload registers. The Watchdog Timer then counts down to 000000H unless a WDT instruction is executed by the eZ8[™] CPU. Execution of the WDT instruction causes the downcounter to be reloaded with the WDT Reload value stored in the Watchdog Timer Reload registers. Counting resumes following the reload operation.

When the 64K Series devices are operating in DEBUG Mode (through the On-Chip Debugger), the Watchdog Timer is continuously refreshed to prevent spurious Watchdog Timer time-outs.

Watchdog Timer Time-Out Response

The Watchdog Timer times out when the counter reaches 000000H. A time-out of the Watchdog Timer generates either an interrupt or a Reset. The WDT_RES Option Bit determines the time-out response of the Watchdog Timer. For information on programming of the WDT_RES Option Bit, see [Option Bits](#) on page 195.

WDT Interrupt in Normal Operation

If configured to generate an interrupt when a time-out occurs, the Watchdog Timer issues an interrupt request to the interrupt controller and sets the WDT status bit in the Watchdog Timer Control register. If interrupts are enabled, the eZ8 CPU responds to the interrupt request by fetching the Watchdog Timer interrupt vector and executing code from the vector address. After time-out and interrupt generation, the Watchdog Timer counter rolls over to its maximum value of FFFFFFFH and continues counting. The Watchdog Timer counter is not automatically returned to its Reload Value.

WDT Interrupt in STOP Mode

If configured to generate an interrupt when a time-out occurs and the 64K Series devices are in STOP mode, the Watchdog Timer automatically initiates a Stop Mode Recovery and generates an interrupt request. Both the WDT status bit and the STOP bit in the Watchdog Timer Control register are set to 1 following WDT time-out in STOP mode. For more information on Stop Mode Recovery, see [Reset and Stop Mode Recovery](#) on page 47.

If interrupts are enabled, following completion of the Stop Mode Recovery the eZ8 CPU responds to the interrupt request by fetching the Watchdog Timer interrupt vector and executing code from the vector address.

WDT Reset in Normal Operation

If configured to generate a Reset when a time-out occurs, the Watchdog Timer forces the device into the Reset state. The WDT status bit in the Watchdog Timer Control register is set to 1. For more information on Reset, see [Reset and Stop Mode Recovery](#) on page 47.

WDT Reset in STOP Mode

If enabled in STOP mode and configured to generate a Reset when a time-out occurs and the device is in STOP mode, the Watchdog Timer initiates a Stop Mode Recovery. Both the WDT status bit and the STOP bit in the Watchdog Timer Control register are set to 1 following WDT time-out in STOP mode. Default operation is for the WDT and its RC oscillator to be enabled during STOP mode.

WDT RC Disable in STOP Mode

To minimize power consumption in STOP Mode, the WDT and its RC oscillator can be disabled in STOP mode. The following sequence configures the WDT to be disabled when the 64K Series devices enter STOP Mode following execution of a STOP instruction:

1. Write 55H to the Watchdog Timer Control register (WDTCTL).
2. Write AAH to the Watchdog Timer Control register (WDTCTL).
3. Write 81H to the Watchdog Timer Control register (WDTCTL) to configure the WDT and its oscillator to be disabled during STOP Mode. Alternatively, write 00H to the Watchdog Timer Control register (WDTCTL) as the third step in this sequence to reconfigure the WDT and its oscillator to be enabled during STOP mode.

This sequence only affects WDT operation in STOP mode.

Watchdog Timer Reload Unlock Sequence

Writing the unlock sequence to the Watchdog Timer (WDTCTL) Control register address unlocks the three Watchdog Timer Reload Byte registers (WDTU, WDTM, and WDTL) to allow changes to the time-out period. These write operations to the WDTCTL register address produce no effect on the bits in the WDTCTL register. The locking mechanism prevents spurious writes to the Reload registers. Follow the steps below to unlock the Watchdog Timer Reload Byte registers (WDTU, WDTM, and WDTL) for write access.

1. Write 55H to the Watchdog Timer Control register (WDTCTL).
2. Write AAH to the Watchdog Timer Control register (WDTCTL).
3. Write the Watchdog Timer Reload Upper Byte register (WDTU).
4. Write the Watchdog Timer Reload High Byte register (WDTM).

- Write the Watchdog Timer Reload Low Byte register (WDTL).

All steps of the Watchdog Timer Reload Unlock sequence must be written in the order just listed. There must be no other register writes between each of these operations. If a register write occurs, the lock state machine resets and no further writes can occur, unless the sequence is restarted. The value in the Watchdog Timer Reload registers is loaded into the counter when the Watchdog Timer is first enabled and every time a WDT instruction is executed.

Watchdog Timer Control Register Definitions

Watchdog Timer Control Register

The Watchdog Timer Control (WDTCTL) register (Table 48) is a Read-Only register that indicates the source of the most recent Reset event, indicates a Stop Mode Recovery event, and indicates a Watchdog Timer time-out. Reading this register resets the upper four bits to 0.

Writing the 55H, AAH unlock sequence to the Watchdog Timer Control (WDTCTL) register address unlocks the three Watchdog Timer Reload Byte registers (WDTU, WDTM, and WDTL) to allow changes to the time-out period. These write operations to the WDTCTL register address produce no effect on the bits in the WDTCTL register. The locking mechanism prevents spurious writes to the Reload registers.

Table 48. Watchdog Timer Control Register (WDTCTL)

BITS	7	6	5	4	3	2	1	0
FIELD	POR	STOP	WDT	EXT	Reserved			SM
RESET	See descriptions below			0				
R/W	R							
ADDR	FF0H							

Reset or Stop Mode Recovery Event	POR	STOP	WDT	EXT
Power-On Reset	1	0	0	0
Reset using <u>RESET</u> pin assertion	0	0	0	1
Reset using Watchdog Timer time-out	0	0	1	0
Reset using the On-Chip Debugger (OCDCTL[1] set to 1)	1	0	0	0
Reset from STOP Mode using DBG Pin driven Low	1	0	0	0
Stop Mode Recovery using GPIO pin transition	0	1	0	0
Stop Mode Recovery using Watchdog Timer time-out	0	1	1	0

POR—Power-On Reset Indicator

If this bit is set to 1, a Power-On Reset event occurred. This bit is reset to 0 if a WDT time-out or Stop Mode Recovery occurs. This bit is also reset to 0 when the register is read.

STOP—Stop Mode Recovery Indicator

If this bit is set to 1, a Stop Mode Recovery occurred. If the STOP and WDT bits are both set to 1, the Stop Mode Recovery occurred due to a WDT time-out. If the STOP bit is 1 and the WDT bit is 0, the Stop Mode Recovery was not caused by a WDT time-out. This bit is reset by a Power-On Reset or a WDT time-out that occurred while not in STOP mode. Reading this register also resets this bit.

WDT—Watchdog Timer Time-Out Indicator

If this bit is set to 1, a WDT time-out occurred. A Power-On Reset resets this pin. A Stop Mode Recovery from a change in an input pin also resets this bit. Reading this register resets this bit.

EXT—External Reset Indicator

If this bit is set to 1, a Reset initiated by the external $\overline{\text{RESET}}$ pin occurred. A Power-On Reset or a Stop Mode Recovery from a change in an input pin resets this bit. Reading this register resets this bit.

Reserved

These bits are reserved and must be 0.

SM—STOP Mode Configuration Indicator

0 = Watchdog Timer and its internal RC oscillator will continue to operate in STOP Mode.
1 = Watchdog Timer and its internal RC oscillator will be disabled in STOP Mode.

Watchdog Timer Reload Upper, High and Low Byte Registers

The Watchdog Timer Reload Upper, High and Low Byte (WDTU, WDTH, WDTL) registers (see [Table 49](#) on page 102 through [Table 51](#) on page 102) form the 24-bit reload value that is loaded into the Watchdog Timer when a WDT instruction executes. The 24-bit reload value is {WDTU[7:0], WDTH[7:0], WDTL[7:0]}. Writing to these registers sets the desired Reload Value. Reading from these registers returns the current Watchdog Timer count value.



Caution: *The 24-bit WDT Reload Value must not be set to a value less than 000004H.*

Table 49. Watchdog Timer Reload Upper Byte Register (WDTU)

BITS	7	6	5	4	3	2	1	0
FIELD	WDTU							
RESET	1							
R/W	R/W*							
ADDR	FF1H							
Note: R/W* - Read returns the current WDT count value. Write sets the desired Reload Value.								

WDTU—WDT Reload Upper Byte
Most significant byte, Bits[23:16], of the 24-bit WDT reload value.

Table 50. Watchdog Timer Reload High Byte Register (WDTH)

BITS	7	6	5	4	3	2	1	0
FIELD	WDTH							
RESET	1							
R/W	R/W*							
ADDR	FF2H							
Note: R/W* - Read returns the current WDT count value. Write sets the desired Reload Value.								

WDTH—WDT Reload High Byte
Middle byte, Bits[15:8], of the 24-bit WDT reload value.

Table 51. Watchdog Timer Reload Low Byte Register (WDTL)

BITS	7	6	5	4	3	2	1	0
FIELD	WDTL							
RESET	1							
R/W	R/W*							
ADDR	FF3H							
Note: R/W* - Read returns the current WDT count value. Write sets the desired Reload Value.								

WDTL—WDT Reload Low
Least significant byte, Bits[7:0], of the 24-bit WDT reload value.

UART

Overview

The Universal Asynchronous Receiver/Transmitter (UART) is a full-duplex communication channel capable of handling asynchronous data transfers. The UART uses a single 8-bit data mode with selectable parity. Features of the UART include:

- 8-bit asynchronous data transfer
- Selectable even- and odd-parity generation and checking
- Option of one or two Stop bits
- Separate transmit and receive interrupts
- Framing, parity, overrun and break detection
- Separate transmit and receive enables
- 16-bit Baud Rate Generator (BRG)
- Selectable MULTIPROCESSOR (9-bit) mode with three configurable interrupt schemes
- Baud Rate Generator timer mode
- Driver Enable output for external bus transceivers

Architecture

The UART consists of three primary functional blocks: Transmitter, Receiver, and Baud rate generator. The UART's transmitter and receiver function independently, but employ the same baud rate and data format. [Figure 13](#) on page 104 displays the UART architecture.

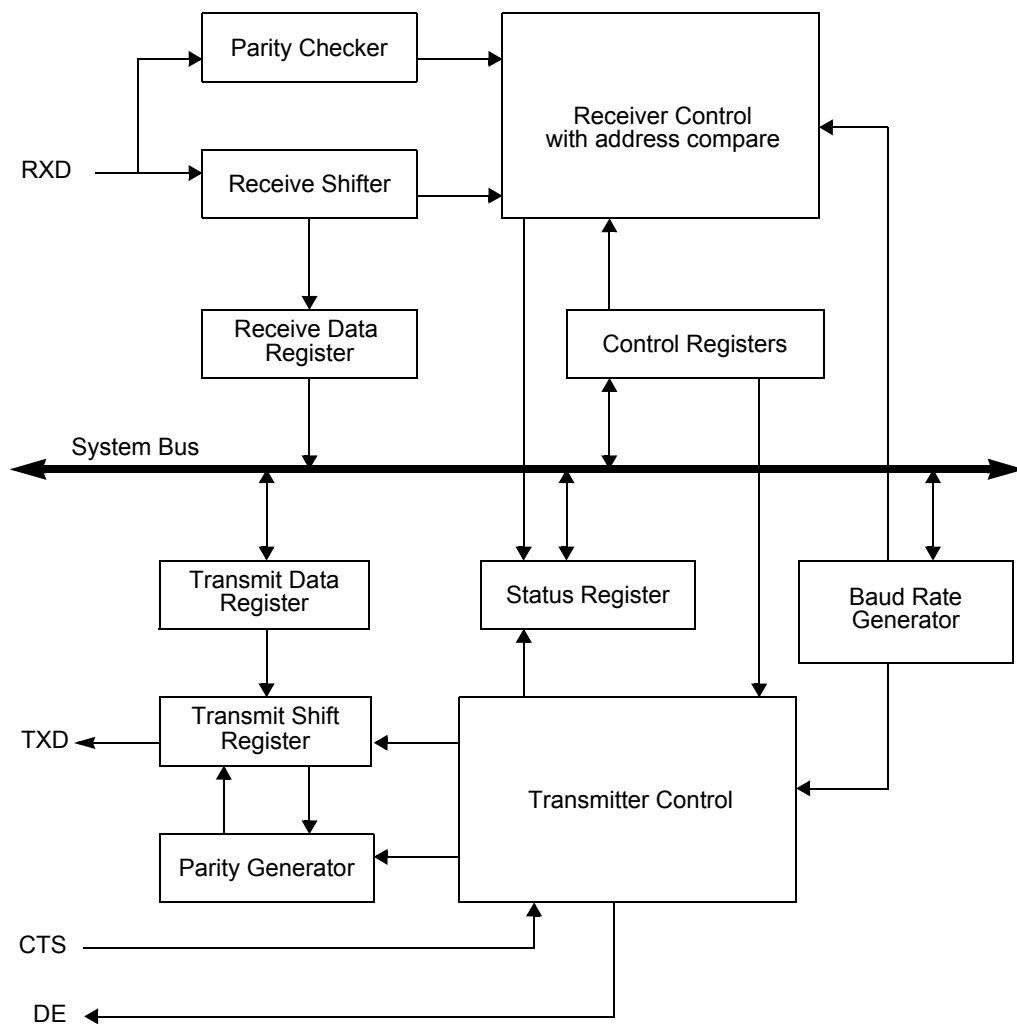

Figure 13. UART Block Diagram

Operation

Data Format

The UART always transmits and receives data in an 8-bit data format, least-significant bit first. An even or odd parity bit can be optionally added to the data stream. Each character begins with an active Low Start bit and ends with either 1 or 2 active High Stop bits.

[Figure 14](#) and [Figure 15](#) on page 105 displays the asynchronous data format employed by the UART without parity and with parity, respectively.

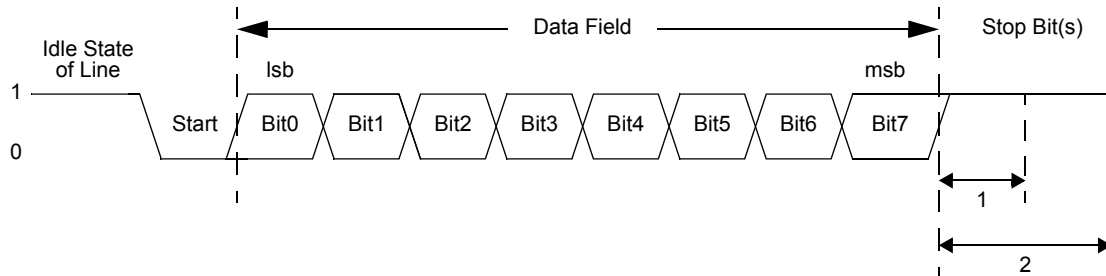

Figure 14. UART Asynchronous Data Format without Parity

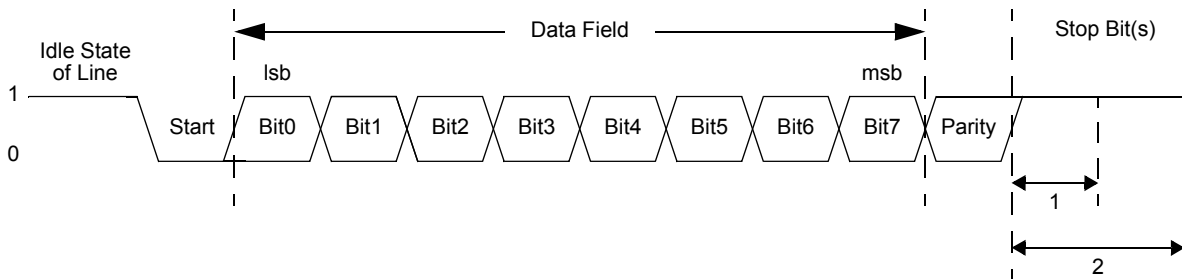

Figure 15. UART Asynchronous Data Format with Parity

Transmitting Data using the Polled Method

Follow the steps below to transmit data using the polled method of operation:

1. Write to the UART Baud Rate High and Low Byte registers to set the desired baud rate.
2. Enable the UART pin functions by configuring the associated GPIO Port pins for alternate function operation.
3. If MULTIPROCESSOR mode is desired, write to the UART Control 1 register to enable MULTIPROCESSOR (9-bit) mode functions.
 - Set the MULTIPROCESSOR Mode Select (MPEN) to Enable MULTIPROCESSOR mode.
4. Write to the UART Control 0 register to:
 - Set the transmit enable bit (TEN) to enable the UART for data transmission
 - If parity is desired and MULTIPROCESSOR mode is not enabled, set the parity enable bit (PEN) and select either Even or Odd parity (PSEL).

- Set or clear the \overline{CTSE} bit to enable or disable control from the remote receiver using the \overline{CTS} pin.
5. Check the \overline{TDRE} bit in the UART Status 0 register to determine if the Transmit Data register is empty (indicated by a 1). If empty, continue to [step 6](#). If the Transmit Data register is full (indicated by a 0), continue to monitor the \overline{TDRE} bit until the Transmit Data register becomes available to receive new data.
 6. Write the UART Control 1 register to select the outgoing address bit.
 7. Set the MULTIPROCESSOR Bit Transmitter (MPBT) if sending an address byte, clear it if sending a data byte.
 8. Write the data byte to the UART Transmit Data register. The transmitter automatically transfers the data to the Transmit Shift register and transmits the data.
 9. If desired and MULTIPROCESSOR mode is enabled, make any changes to the MULTIPROCESSOR Bit Transmitter (MPBT) value.
 10. To transmit additional bytes, return to [step 5](#).

Transmitting Data using the Interrupt-Driven Method

The UART transmitter interrupt indicates the availability of the Transmit Data register to accept new data for transmission. Follow the steps below to configure the UART for interrupt-driven data transmission:

1. Write to the UART Baud Rate High and Low Byte registers to set the desired baud rate.
2. Enable the UART pin functions by configuring the associated GPIO Port pins for alternate function operation.
3. Execute a DI instruction to disable interrupts.
4. Write to the Interrupt control registers to enable the UART Transmitter interrupt and set the desired priority.
5. If MULTIPROCESSOR mode is desired, write to the UART Control 1 register to enable MULTIPROCESSOR (9-bit) mode functions.
6. Set the MULTIPROCESSOR Mode Select (MPEN) to Enable MULTIPROCESSOR mode.
7. Write to the UART Control 0 register to:
 - Set the transmit enable bit (\overline{TEN}) to enable the UART for data transmission.
 - Enable parity, if desired and if MULTIPROCESSOR mode is not enabled, and select either even or odd parity.
 - Set or clear the \overline{CTSE} bit to enable or disable control from the remote receiver via the \overline{CTS} pin.

8. Execute an EI instruction to enable interrupts.

The UART is now configured for interrupt-driven data transmission. Because the UART Transmit Data register is empty, an interrupt is generated immediately. When the UART Transmit interrupt is detected, the associated interrupt service routine performs the following:

1. Write the UART Control 1 register to select the outgoing address bit:
 - Set the MULTIPROCESSOR Bit Transmitter (MPBT) if sending an address byte, clear it if sending a data byte.
2. Write the data byte to the UART Transmit Data register. The transmitter automatically transfers the data to the Transmit Shift register and transmits the data.
3. Clear the UART Transmit interrupt bit in the applicable Interrupt Request register.
4. Execute the IRET instruction to return from the interrupt-service routine and wait for the Transmit Data register to again become empty.

Receiving Data using the Polled Method

Follow the steps below to configure the UART for polled data reception:

1. Write to the UART Baud Rate High and Low Byte registers to set the desired baud rate.
2. Enable the UART pin functions by configuring the associated GPIO Port pins for alternate function operation.
3. Write to the UART Control 1 register to enable MULTIPROCESSOR mode functions, if desired.
4. Write to the UART Control 0 register to:
 - Set the receive enable bit (REN) to enable the UART for data reception.
 - Enable parity, if desired and if MULTIPROCESSOR mode is not enabled, and select either even or odd parity.
5. Check the RDA bit in the UART Status 0 register to determine if the Receive Data register contains a valid data byte (indicated by a 1). If RDA is set to 1 to indicate available data, continue to [step 6](#). If the Receive Data register is empty (indicated by a 0), continue to monitor the RDA bit awaiting reception of the valid data.
6. Read data from the UART Receive Data register. If operating in MULTIPROCESSOR (9-bit) mode, further actions may be required depending on the MULTIPROCESSOR Mode bits MPMD[1:0].
7. Return to [step 5](#) to receive additional data.

Receiving Data using the Interrupt-Driven Method

The UART Receiver interrupt indicates the availability of new data (as well as error conditions). Follow the steps below to configure the UART receiver for interrupt-driven operation:

1. Write to the UART Baud Rate High and Low Byte registers to set the desired baud rate.
2. Enable the UART pin functions by configuring the associated GPIO Port pins for alternate function operation.
3. Execute a `DI` instruction to disable interrupts.
4. Write to the Interrupt control registers to enable the UART Receiver interrupt and set the desired priority.
5. Clear the UART Receiver interrupt in the applicable Interrupt Request register.
6. Write to the UART Control 1 Register to enable MULTIPROCESSOR (9-bit) mode functions, if desired.
 - Set the MULTIPROCESSOR Mode Select (`MPEN`) to Enable MULTIPROCESSOR mode.
 - Set the MULTIPROCESSOR Mode Bits, `MPMD [1 : 0]`, to select the desired address matching scheme.
 - Configure the UART to interrupt on received data and errors or errors only (interrupt on errors only is unlikely to be useful for Z8 Encore! devices without a DMA block).
7. Write the device address to the Address Compare Register (automatic multiprocessor modes only).
8. Write to the UART Control 0 register to:
 - Set the receive enable bit (`REN`) to enable the UART for data reception.
 - Enable parity, if desired and if MULTIPROCESSOR mode is not enabled, and select either even or odd parity.
9. Execute an `EI` instruction to enable interrupts.

The UART is now configured for interrupt-driven data reception. When the UART Receiver interrupt is detected, the associated interrupt service routine performs the following:

1. Check the UART Status 0 register to determine the source of the interrupt - error, break, or received data.
2. If the interrupt was caused by data available, read the data from the UART Receive Data register. If operating in MULTIPROCESSOR (9-bit) mode, further actions may be required depending on the MULTIPROCESSOR Mode bits `MPMD [1 : 0]`.

3. Clear the UART Receiver interrupt in the applicable Interrupt Request register.
4. Execute the IRET instruction to return from the interrupt-service routine and await more data.

Clear To Send (CTS) Operation

The CTS pin, if enabled by the CTSE bit of the UART Control 0 register, performs flow control on the outgoing transmit datastream. The Clear To Send (CTS) input pin is sampled one system clock before beginning any new character transmission. To delay transmission of the next data character, an external receiver must deassert CTS at least one system clock cycle before a new data transmission begins. For multiple character transmissions, this would typically be done during Stop Bit transmission. If CTS deasserts in the middle of a character transmission, the current character is sent completely.

MULTIPROCESSOR (9-bit) Mode

The UART has a MULTIPROCESSOR (9-bit) mode that uses an extra (9th) bit for selective communication when a number of processors share a common UART bus. In MULTIPROCESSOR mode (also referred to as 9-Bit mode), the multiprocessor bit (MP) is transmitted immediately following the 8-bits of data and immediately preceding the Stop bit(s) as displayed in Figure 16. The character format is:

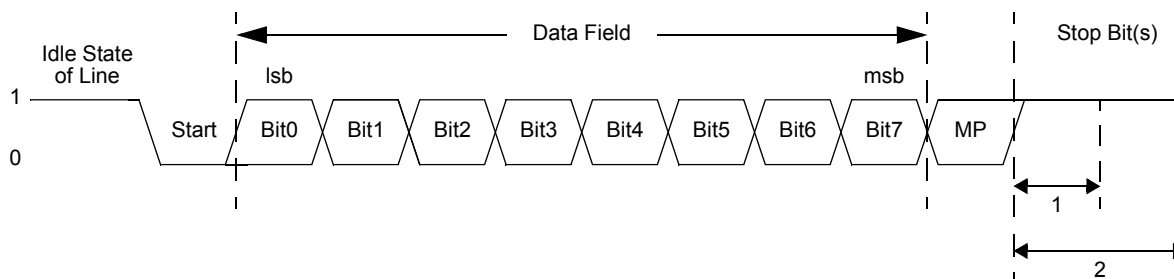

Figure 16. UART Asynchronous MULTIPROCESSOR Mode Data Format

In MULTIPROCESSOR (9-bit) mode, the Parity bit location (9th bit) becomes the MULTIPROCESSOR control bit. The UART Control 1 and Status 1 registers provide MULTIPROCESSOR (9-bit) mode control and status information. If an automatic address matching scheme is enabled, the UART Address Compare register holds the network address of the device.

MULTIPROCESSOR (9-bit) Mode Receive Interrupts

When MULTIPROCESSOR mode is enabled, the UART only processes frames addressed to it. The determination of whether a frame of data is addressed to the UART can be made in hardware, software or some combination of the two, depending on the multiprocessor

configuration bits. In general, the address compare feature reduces the load on the CPU, since it does not need to access the UART when it receives data directed to other devices on the multi-node network. The following three MULTIPROCESSOR modes are available in hardware:

- Interrupt on all address bytes.
- Interrupt on matched address bytes and correctly framed data bytes.
- Interrupt only on correctly framed data bytes.

These modes are selected with $MPMD[1:0]$ in the UART Control 1 Register. For all MULTIPROCESSOR modes, bit $MPEN$ of the UART Control 1 Register must be set to 1.

The first scheme is enabled by writing 01b to $MPMD[1:0]$. In this mode, all incoming address bytes cause an interrupt, while data bytes never cause an interrupt. The interrupt service routine must manually check the address byte that caused triggered the interrupt. If it matches the UART address, the software clears $MPMD[0]$. At this point, each new incoming byte interrupts the CPU. The software is then responsible for determining the end of the frame. It checks for end-of-frame by reading the $MPRX$ bit of the UART Status 1 Register for each incoming byte. If $MPRX=1$, a new frame has begun. If the address of this new frame is different from the UART's address, then set $MPMD[0]$ to 1 causing the UART interrupts to go inactive until the next address byte. If the new frame's address matches the UART's, the data in the new frame is processed as well.

The second scheme is enabled by setting $MPMD[1:0]$ to 10b and writing the UART's address into the UART Address Compare Register. This mode introduces more hardware control, interrupting only on frames that match the UART's address. When an incoming address byte does not match the UART's address, it is ignored. All successive data bytes in this frame are also ignored. When a matching address byte occurs, an interrupt is issued and further interrupts now occur on each successive data byte. The first data byte in the frame contains the $NEWFRM=1$ in the UART Status 1 Register. When the next address byte occurs, the hardware compares it to the UART's address. If there is a match, the interrupts continue sand the $NEWFRM$ bit is set for the first byte of the new frame. If there is no match, then the UART ignores all incoming bytes until the next address match.

The third scheme is enabled by setting $MPMD[1:0]$ to 11b and by writing the UART's address into the UART Address Compare Register. This mode is identical to the second scheme, except that there are no interrupts on address bytes. The first data byte of each frame is still accompanied by a $NEWFRM$ assertion.

External Driver Enable

The UART provides a Driver Enable (DE) signal for off-chip bus transceivers. This feature reduces the software overhead associated with using a GPIO pin to control the transceiver when communicating on a multi-transceiver bus, such as RS-485.

Driver Enable is an active High signal that envelopes the entire transmitted data frame including parity and Stop bits as displayed in [Figure 17](#). The Driver Enable signal asserts

when a byte is written to the UART Transmit Data register. The Driver Enable signal asserts at least one UART bit period and no greater than two UART bit periods before the Start bit is transmitted. This timing allows a setup time to enable the transceiver. The Driver Enable signal deasserts one system clock period after the last Stop bit is transmitted. This one system clock delay allows both time for data to clear the transceiver before disabling it, as well as the ability to determine if another character follows the current character. In the event of back to back characters (new data must be written to the Transmit Data Register before the previous character is completely transmitted) the DE signal is not deasserted between characters. The DEPOL bit in the UART Control Register 1 sets the polarity of the Driver Enable signal.

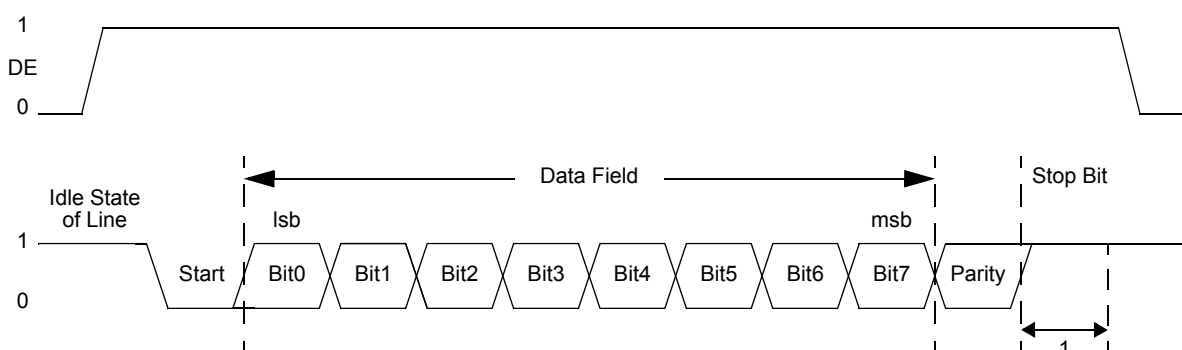

Figure 17. UART Driver Enable Signal Timing (shown with 1 Stop Bit and Parity)

The Driver Enable to Start bit setup time is calculated as follows:

$$\left(\frac{1}{\text{Baud Rate (Hz)}}\right) \leq \text{DE to Start Bit Setup Time (s)} \leq \left(\frac{2}{\text{Baud Rate (Hz)}}\right)$$

UART Interrupts

The UART features separate interrupts for the transmitter and the receiver. In addition, when the UART primary functionality is disabled, the Baud Rate Generator can also function as a basic timer with interrupt capability.

Transmitter Interrupts

The transmitter generates a single interrupt when the Transmit Data Register Empty bit (TDRE) is set to 1. This indicates that the transmitter is ready to accept new data for transmission. The TDRE interrupt occurs after the Transmit shift register has shifted the first bit of data out. At this point, the Transmit Data register may be written with the next character to send. This provides 7 bit periods of latency to load the Transmit Data register before the Transmit shift register completes shifting the current character. Writing to the UART Transmit Data register clears the TDRE bit to 0.

Receiver Interrupts

The receiver generates an interrupt when any of the following occurs:

- A data byte has been received and is available in the UART Receive Data register. This interrupt can be disabled independent of the other receiver interrupt sources. The received data interrupt occurs once the receive character has been received and placed in the Receive Data register. Software must respond to this received data available condition before the next character is completely received to avoid an overrun error.

► **Note:** *In MULTIPROCESSOR mode ($MPEN = 1$), the receive data interrupts are dependent on the multiprocessor configuration and the most recent address byte.*

- A break is received
- An overrun is detected
- A data framing error is detected

UART Overrun Errors

When an overrun error condition occurs the UART prevents overwriting of the valid data currently in the Receive Data register. The Break Detect and Overrun status bits are not displayed until after the valid data has been read.

After the valid data has been read, the UART Status 0 register is updated to indicate the overrun condition (and Break Detect, if applicable). The `RDA` bit is set to 1 to indicate that the Receive Data register contains a data byte. However, because the overrun error occurred, this byte may not contain valid data and should be ignored. The `BRKD` bit indicates if the overrun was caused by a break condition on the line. After reading the status byte indicating an overrun error, the Receive Data register must be read again to clear the error bits in the UART Status 0 register. Updates to the Receive Data register occur only when the next data word is received.

UART Data and Error Handling Procedure

Figure 18 on page 113 displays the recommended procedure for use in UART receiver interrupt service routines.

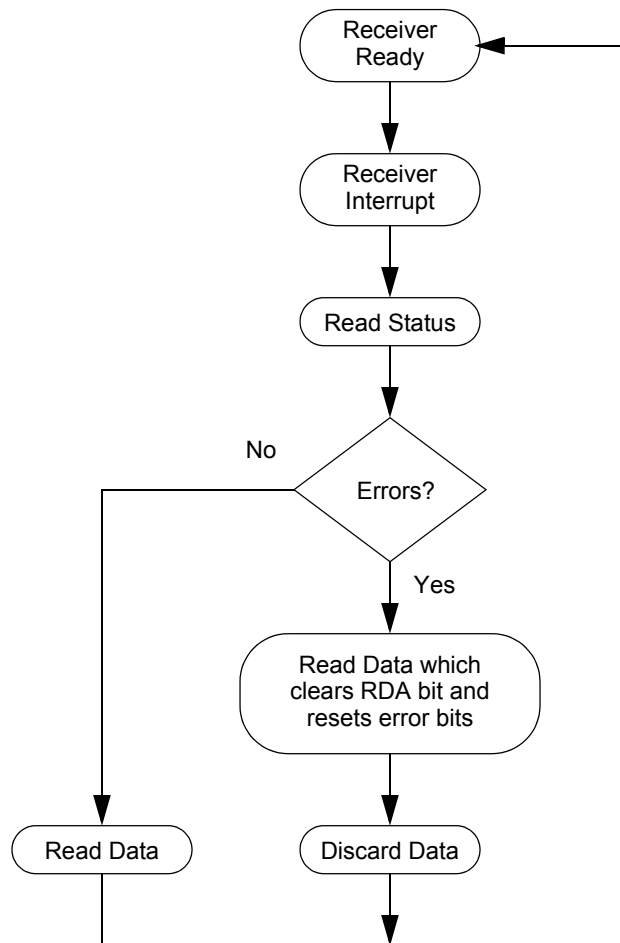

Figure 18. UART Receiver Interrupt Service Routine Flow

Baud Rate Generator Interrupts

If the Baud Rate Generator interrupt enable is set, the UART Receiver interrupt asserts when the UART Baud Rate Generator reloads. This action allows the Baud Rate Generator to function as an additional counter if the UART functionality is not employed.

UART Baud Rate Generator

The UART Baud Rate Generator creates a lower frequency baud rate clock for data transmission. The input to the Baud Rate Generator is the system clock. The UART Baud Rate High and Low Byte registers combine to create a 16-bit baud rate divisor value



(BRG[15:0]) that sets the data transmission rate (baud rate) of the UART. The UART data rate is calculated using the following equation:

$$\text{UART Data Rate (bits/s)} = \frac{\text{System Clock Frequency (Hz)}}{16 \times \text{UART Baud Rate Divisor Value}}$$

When the UART is disabled, the Baud Rate Generator can function as a basic 16-bit timer with interrupt on time-out. To configure the Baud Rate Generator as a timer with interrupt on time-out, complete the following procedure:

1. Disable the UART by clearing the REN and TEN bits in the UART Control 0 register to 0.
2. Load the desired 16-bit count value into the UART Baud Rate High and Low Byte registers.
3. Enable the Baud Rate Generator timer function and associated interrupt by setting the BRGCTL bit in the UART Control 1 register to 1.

When configured as a general purpose timer, the interrupt interval is calculated using the following equation:

$$\text{Interrupt Interval}(s) = \text{System Clock Period}(s) \times \text{BRG}[15:0]$$

UART Control Register Definitions

The UART control registers support the UART and the associated Infrared Encoder/Decoders. For more information on the infrared operation, see [Infrared Encoder/Decoder](#) on page 125.

UART Transmit Data Register

Data bytes written to the UART Transmit Data register ([Table 52](#)) are shifted out on the TXD_x pin. The Write-only UART Transmit Data register shares a Register File address with the Read-only UART Receive Data register.

Table 52. UART Transmit Data Register (UxTXD)

BITS	7	6	5	4	3	2	1	0
FIELD	TXD							
RESET	X							
R/W	W							
ADDR	F40H and F48H							



TXD—Transmit Data
UART transmitter data byte to be shifted out through the TXDx pin.

UART Receive Data Register

Data bytes received through the RXDx pin are stored in the UART Receive Data register (Table 53). The Read-only UART Receive Data register shares a Register File address with the Write-only UART Transmit Data register.

Table 53. UART Receive Data Register (UxRXD)

BITS	7	6	5	4	3	2	1	0
FIELD	RXD							
RESET	X							
R/W	R							
ADDR	F40H and F48H							

RXD—Receive Data
UART receiver data byte from the RXDx pin

UART Status 0 Register

The UART Status 0 and Status 1 registers (Table 54 and Table 55 on page 117) identify the current UART operating configuration and status.

Table 54. UART Status 0 Register (UxSTAT0)

BITS	7	6	5	4	3	2	1	0
FIELD	RDA	PE	OE	FE	BRKD	TDRE	TXE	CTS
RESET	0						1	X
R/W	R							
ADDR	F41H and F49H							

RDA—Receive Data Available
This bit indicates that the UART Receive Data register has received data. Reading the UART Receive Data register clears this bit.
0 = The UART Receive Data register is empty.
1 = There is a byte in the UART Receive Data register.

PE—Parity Error

This bit indicates that a parity error has occurred. Reading the UART Receive Data register clears this bit.

0 = No parity error occurred.

1 = A parity error occurred.

OE—Overrun Error

This bit indicates that an overrun error has occurred. An overrun occurs when new data is received and the UART Receive Data register has not been read. If the RDA bit is reset to 0, then reading the UART Receive Data register clears this bit.

0 = No overrun error occurred.

1 = An overrun error occurred.

FE—Framing Error

This bit indicates that a framing error (no Stop bit following data reception) was detected. Reading the UART Receive Data register clears this bit.

0 = No framing error occurred.

1 = A framing error occurred.

BRKD—Break Detect

This bit indicates that a break occurred. If the data bits, parity/multiprocessor bit, and Stop bit(s) are all zeros then this bit is set to 1. Reading the UART Receive Data register clears this bit.

0 = No break occurred.

1 = A break occurred.

TDRE—Transmitter Data Register Empty

This bit indicates that the UART Transmit Data register is empty and ready for additional data. Writing to the UART Transmit Data register resets this bit.

0 = Do not write to the UART Transmit Data register.

1 = The UART Transmit Data register is ready to receive an additional byte to be transmitted.

TXE—Transmitter Empty

This bit indicates that the transmit shift register is empty and character transmission is finished.

0 = Data is currently transmitting.

1 = Transmission is complete.

CTS— $\overline{\text{CTS}}$ signal

When this bit is read it returns the level of the $\overline{\text{CTS}}$ signal.

UART Status 1 Register

This register contains multiprocessor control and status bits.

Table 55. UART Status 1 Register (UxSTAT1)

BITS	7	6	5	4	3	2	1	0
FIELD	Reserved						NEWFRM	MPRX
RESET	0							
R/W	R			R/W			R	
ADDR	F44H and F4CH							

Reserved—Must be 0.

NEWFRM—Status bit denoting the start of a new frame. Reading the UART Receive Data register resets this bit to 0.

0 = The current byte is not the first data byte of a new frame.

1 = The current byte is the first data byte of a new frame.

MPRX—Multiprocessor Receive

Returns the value of the last multiprocessor bit received. Reading from the UART Receive Data register resets this bit to 0.

UART Control 0 and Control 1 Registers

The UART Control 0 and Control 1 registers (see [Table 56](#) and [Table 57](#) on page 118) configure the properties of the UART's transmit and receive operations. The UART Control registers must not be written while the UART is enabled.

Table 56. UART Control 0 Register (UxCTL0)

BITS	7	6	5	4	3	2	1	0
FIELD	TEN	REN	CTSE	PEN	PSEL	SBRK	STOP	LBEN
RESET	0							
R/W	R/W							
ADDR	F42H and F4AH							

TEN—Transmit Enable

This bit enables or disables the transmitter. The enable is also controlled by the $\overline{\text{CTS}}$ signal and the CTSE bit. If the $\overline{\text{CTS}}$ signal is low and the CTSE bit is 1, the transmitter is enabled.

0 = Transmitter disabled.

1 = Transmitter enabled.



REN—Receive Enable

This bit enables or disables the receiver.

0 = Receiver disabled.

1 = Receiver enabled.

CTSE—CTS Enable

0 = The $\overline{\text{CTS}}$ signal has no effect on the transmitter.

1 = The UART recognizes the $\overline{\text{CTS}}$ signal as an enable control from the transmitter.

PEN—Parity Enable

This bit enables or disables parity. Even or odd is determined by the PSEL bit. It is overridden by the MPEN bit.

0 = Parity is disabled.

1 = The transmitter sends data with an additional parity bit and the receiver receives an additional parity bit.

PSEL—Parity Select

0 = Even parity is transmitted and expected on all received data.

1 = Odd parity is transmitted and expected on all received data.

SBRK—Send Break

This bit pauses or breaks data transmission. Sending a break interrupts any transmission in progress, so ensure that the transmitter has finished sending data before setting this bit.

0 = No break is sent.

1 = The output of the transmitter is zero.

STOP—Stop Bit Select

0 = The transmitter sends one stop bit.

1 = The transmitter sends two stop bits.

LBEN—Loop Back Enable

0 = Normal operation.

1 = All transmitted data is looped back to the receiver.

Table 57. UART Control 1 Register (UxCTL1)

BITS	7	6	5	4	3	2	1	0
FIELD	MPMD[1]	MPEN	MPMD[0]	MPBT	DEPOL	BRGCTL	RDAIRQ	IREN
RESET	0							
R/W	R/W							
ADDR	F43H and F4BH							

MPMD[1:0]—MULTIPROCESSOR Mode

If MULTIPROCESSOR (9-bit) mode is enabled,

00 = The UART generates an interrupt request on all received bytes (data and address).

- 01 = The UART generates an interrupt request only on received address bytes.
- 10 = The UART generates an interrupt request when a received address byte matches the value stored in the Address Compare Register and on all successive data bytes until an address mismatch occurs.
- 11 = The UART generates an interrupt request on all received data bytes for which the most recent address byte matched the value in the Address Compare Register.

MPEN—MULTIPROCESSOR (9-bit) Enable

This bit is used to enable MULTIPROCESSOR (9-bit) mode.

0 = Disable MULTIPROCESSOR (9-bit) mode.

1 = Enable MULTIPROCESSOR (9-bit) mode.

MPBT—MULTIPROCESSOR Bit Transmit

This bit is applicable only when MULTIPROCESSOR (9-bit) mode is enabled.

0 = Send a 0 in the multiprocessor bit location of the data stream (9th bit).

1 = Send a 1 in the multiprocessor bit location of the data stream (9th bit).

DEPOL—Driver Enable Polarity

0 = DE signal is Active High.

1 = DE signal is Active Low.

BRGCTL—Baud Rate Control

This bit causes different UART behavior depending on whether the UART receiver is enabled ($REN = 1$ in the UART Control 0 Register).

When the UART receiver is not enabled, this bit determines whether the Baud Rate Generator issues interrupts.

0 = Reads from the Baud Rate High and Low Byte registers return the BRG Reload Value

1 = The Baud Rate Generator generates a receive interrupt when it counts down to 0.

Reads from the Baud Rate High and Low Byte registers return the current BRG count value.

When the UART receiver is enabled, this bit allows reads from the Baud Rate Registers to return the BRG count value instead of the Reload Value.

0 = Reads from the Baud Rate High and Low Byte registers return the BRG Reload Value.

1 = Reads from the Baud Rate High and Low Byte registers return the current BRG count value. Unlike the Timers, there is no mechanism to latch the High Byte when the Low Byte is read.

\overline{RDAIRQ} —Receive Data Interrupt Enable

0 = Received data and receiver errors generates an interrupt request to the Interrupt Controller.

1 = Received data does not generate an interrupt request to the Interrupt Controller. Only receiver errors generate an interrupt request.

IREN—Infrared Encoder/Decoder Enable

0 = Infrared Encoder/Decoder is disabled. UART operates normally operation.



1 = Infrared Encoder/Decoder is enabled. The UART transmits and receives data through the Infrared Encoder/Decoder.

UART Address Compare Register

The UART Address Compare register (Table 58) stores the multi-node network address of the UART. When the MPMD[1] bit of UART Control Register 0 is set, all incoming address bytes are compared to the value stored in the Address Compare register. Receive interrupts and RDA assertions only occur in the event of a match.

Table 58. UART Address Compare Register (UxADDR)

BITS	7	6	5	4	3	2	1	0
FIELD	COMP_ADDR							
RESET	0							
R/W	R/W							
ADDR	F45H and F4DH							

COMP_ADDR—Compare Address
This 8-bit value is compared to the incoming address bytes.

UART Baud Rate High and Low Byte Registers

The UART Baud Rate High and Low Byte registers (see Table 59 and Table 60 on page 121) combine to create a 16-bit baud rate divisor value (BRG[15:0]) that sets the data transmission rate (baud rate) of the UART. To configure the Baud Rate Generator as a timer with interrupt on time-out, complete the following procedure:

1. Disable the UART by clearing the REN and TEN bits in the UART Control 0 register to 0.
2. Load the desired 16-bit count value into the UART Baud Rate High and Low Byte registers.
3. Enable the Baud Rate Generator timer function and associated interrupt by setting the BRGCTL bit in the UART Control 1 register to 1.

When configured as a general purpose timer, the UART BRG interrupt interval is calculated using the following equation:

$$\text{UART BRG Interrupt Interval}(s) = \text{System Clock Period}(s) \times \text{BRG}[15:0]$$

Table 59. UART Baud Rate High Byte Register (UxBRH)

BITS	7	6	5	4	3	2	1	0
FIELD	BRH							
RESET	1							
R/W	R/W							
ADDR	F46H and F4EH							

Table 60. UART Baud Rate Low Byte Register (UxBRL)

BITS	7	6	5	4	3	2	1	0
FIELD	BRL							
RESET	1							
R/W	R/W							
ADDR	F47H and F4FH							

For a given UART data rate, the integer baud rate divisor value is calculated using the following equation:

$$\text{UART Baud Rate Divisor Value (BRG)} = \text{Round}\left(\frac{\text{System Clock Frequency (Hz)}}{16 \times \text{UART Data Rate (bits/s)}}\right)$$

The baud rate error relative to the desired baud rate is calculated using the following equation:

$$\text{UART Baud Rate Error (\%)} = 100 \times \left(\frac{\text{Actual Data Rate} - \text{Desired Data Rate}}{\text{Desired Data Rate}}\right)$$

For reliable communication, the UART baud rate error must never exceed 5 percent. [Table 61](#) provides information on data rate errors for popular baud rates and commonly used crystal oscillator frequencies.



Table 61. UART Baud Rates

20.0 MHz System Clock				18.432 MHz System Clock			
Desired Rate	BRG Divisor	Actual Rate	Error	Desired Rate	BRG Divisor	Actual Rate	Error
(kHz)	(Decimal)	(kHz)	(%)	(kHz)	(Decimal)	(kHz)	(%)
1250.0	1	1250.0	0.00	1250.0	1	1152.0	-7.84%
625.0	2	625.0	0.00	625.0	2	576.0	-7.84%
250.0	5	250.0	0.00	250.0	5	230.4	-7.84%
115.2	11	113.6	-1.36	115.2	10	115.2	0.00
57.6	22	56.8	-1.36	57.6	20	57.6	0.00
38.4	33	37.9	-1.36	38.4	30	38.4	0.00
19.2	65	19.2	0.16	19.2	60	19.2	0.00
9.60	130	9.62	0.16	9.60	120	9.60	0.00
4.80	260	4.81	0.16	4.80	240	4.80	0.00
2.40	521	2.40	-0.03	2.40	480	2.40	0.00
1.20	1042	1.20	-0.03	1.20	960	1.20	0.00
0.60	2083	0.60	0.02	0.60	1920	0.60	0.00
0.30	4167	0.30	-0.01	0.30	3840	0.30	0.00
16.667 MHz System Clock				11.0592 MHz System Clock			
Desired Rate	BRG Divisor	Actual Rate	Error	Desired Rate	BRG Divisor	Actual Rate	Error
(kHz)	(Decimal)	(kHz)	(%)	(kHz)	(Decimal)	(kHz)	(%)
1250.0	1	1041.69	-16.67	1250.0	N/A	N/A	N/A
625.0	2	520.8	-16.67	625.0	1	691.2	10.59
250.0	4	260.4	4.17	250.0	3	230.4	-7.84
115.2	9	115.7	0.47	115.2	6	115.2	0.00
57.6	18	57.87	0.47	57.6	12	57.6	0.00
38.4	27	38.6	0.47	38.4	18	38.4	0.00
19.2	54	19.3	0.47	19.2	36	19.2	0.00
9.60	109	9.56	-0.45	9.60	72	9.60	0.00
4.80	217	4.80	-0.83	4.80	144	4.80	0.00
2.40	434	2.40	0.01	2.40	288	2.40	0.00



Table 61. UART Baud Rates (Continued)

1.20	868	1.20	0.01	1.20	576	1.20	0.00
0.60	1736	0.60	0.01	0.60	1152	0.60	0.00
0.30	3472	0.30	0.01	0.30	2304	0.30	0.00
10.0 MHz System Clock				5.5296 MHz System Clock			
Desired Rate	BRG Divisor	Actual Rate	Error	Desired Rate	BRG Divisor	Actual Rate	Error
(kHz)	(Decimal)	(kHz)	(%)	(kHz)	(Decimal)	(kHz)	(%)
1250.0	N/A	N/A	N/A	1250.0	N/A	N/A	N/A
625.0	1	625.0	0.00	625.0	N/A	N/A	N/A
250.0	3	208.33	-16.67	250.0	1	345.6	38.24
115.2	5	125.0	8.51	115.2	3	115.2	0.00
57.6	11	56.8	-1.36	57.6	6	57.6	0.00
38.4	16	39.1	1.73	38.4	9	38.4	0.00
19.2	33	18.9	0.16	19.2	18	19.2	0.00
9.60	65	9.62	0.16	9.60	36	9.60	0.00
4.80	130	4.81	0.16	4.80	72	4.80	0.00
2.40	260	2.40	-0.03	2.40	144	2.40	0.00
1.20	521	1.20	-0.03	1.20	288	1.20	0.00
0.60	1042	0.60	-0.03	0.60	576	0.60	0.00
0.30	2083	0.30	0.2	0.30	1152	0.30	0.00
3.579545 MHz System Clock				1.8432 MHz System Clock			
Desired Rate	BRG Divisor	Actual Rate	Error	Desired Rate	BRG Divisor	Actual Rate	Error
(kHz)	(Decimal)	(kHz)	(%)	(kHz)	(Decimal)	(kHz)	(%)
1250.0	N/A	N/A	N/A	1250.0	N/A	N/A	N/A
625.0	N/A	N/A	N/A	625.0	N/A	N/A	N/A
250.0	1	223.72	-10.51	250.0	N/A	N/A	N/A
115.2	2	111.9	-2.90	115.2	1	115.2	0.00
57.6	4	55.9	-2.90	57.6	2	57.6	0.00
38.4	6	37.3	-2.90	38.4	3	38.4	0.00
19.2	12	18.6	-2.90	19.2	6	19.2	0.00



Table 61. UART Baud Rates (Continued)

9.60	23	9.73	1.32	9.60	12	9.60	0.00
4.80	47	4.76	-0.83	4.80	24	4.80	0.00
2.40	93	2.41	0.23	2.40	48	2.40	0.00
1.20	186	1.20	0.23	1.20	96	1.20	0.00
0.60	373	0.60	-0.04	0.60	192	0.60	0.00
0.30	746	0.30	-0.04	0.30	384	0.30	0.00

Infrared Encoder/Decoder

Overview

The 64K Series products contain two fully-functional, high-performance UART to Infrared Encoder/Decoders (Endecs). Each Infrared Endec is integrated with an on-chip UART to allow easy communication between the 64K Series and IrDA Physical Layer Specification, Version 1.3-compliant infrared transceivers. Infrared communication provides secure, reliable, low-cost, point-to-point communication between PCs, PDAs, cell phones, printers, and other infrared enabled devices.

Architecture

Figure 19 displays the architecture of the Infrared Endec.

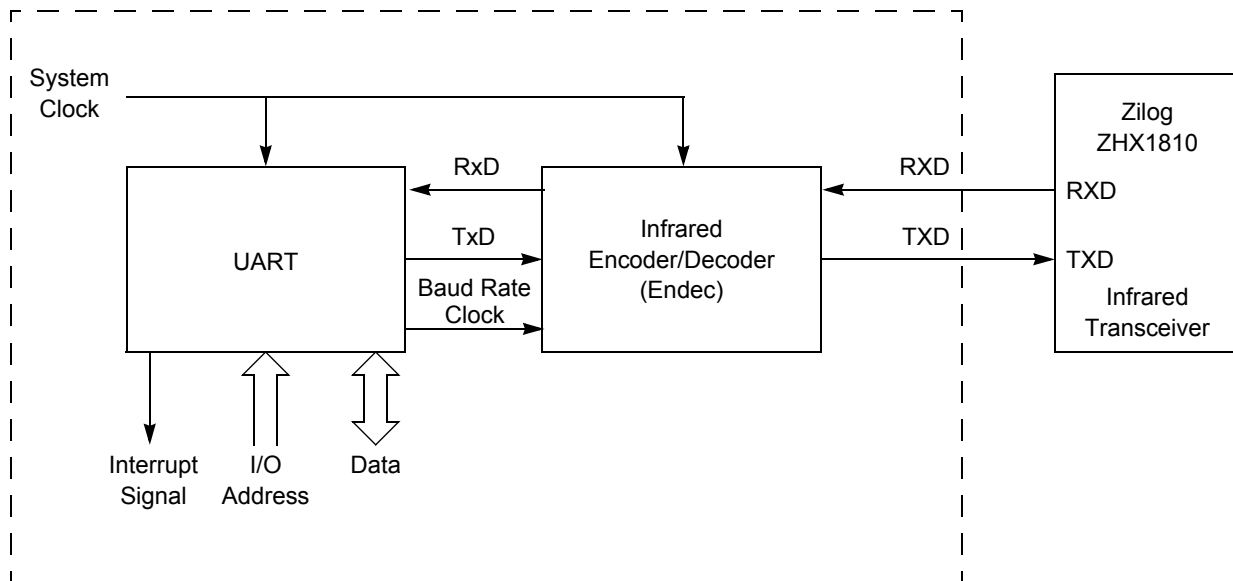

Figure 19. Infrared Data Communication System Block Diagram

Operation

When the Infrared Endec is enabled, the transmit data from the associated on-chip UART is encoded as digital signals in accordance with the IrDA standard and output to the infrared transceiver via the TXD pin. Likewise, data received from the infrared transceiver is passed to the Infrared Endec via the RXD pin, decoded by the Infrared Endec, and then passed to the UART. Communication is half-duplex, which means simultaneous data transmission and reception is not allowed.

The baud rate is set by the UART's Baud Rate Generator and supports IrDA standard baud rates from 9600 baud to 115.2 Kbaud. Higher baud rates are possible, but do not meet IrDA specifications. The UART must be enabled to use the Infrared Endec. The Infrared Endec data rate is calculated using the following equation:

$$\text{Infrared Data Rate (bits/s)} = \frac{\text{System Clock Frequency (Hz)}}{16 \times \text{UART Baud Rate Divisor Value}}$$

Transmitting IrDA Data

The data to be transmitted using the infrared transceiver is first sent to the UART. The UART's transmit signal (TXD) and baud rate clock are used by the IrDA to generate the modulation signal (IR_TXD) that drives the infrared transceiver. Each UART/Infrared data bit is 16-clock wide. If the data to be transmitted is 1, the IR_TXD signal remains low for the full 16-clock period. If the data to be transmitted is 0, a 3-clock high pulse is output following a 7-clock low period. After the 3-clock high pulse, a 6-clock low pulse is output to complete the full 16-clock data period. Figure 20 displays IrDA data transmission.

When the Infrared Endec is enabled, the UART's TXD signal is internal to the 64K Series products while the IR_TXD signal is output through the TXD pin.

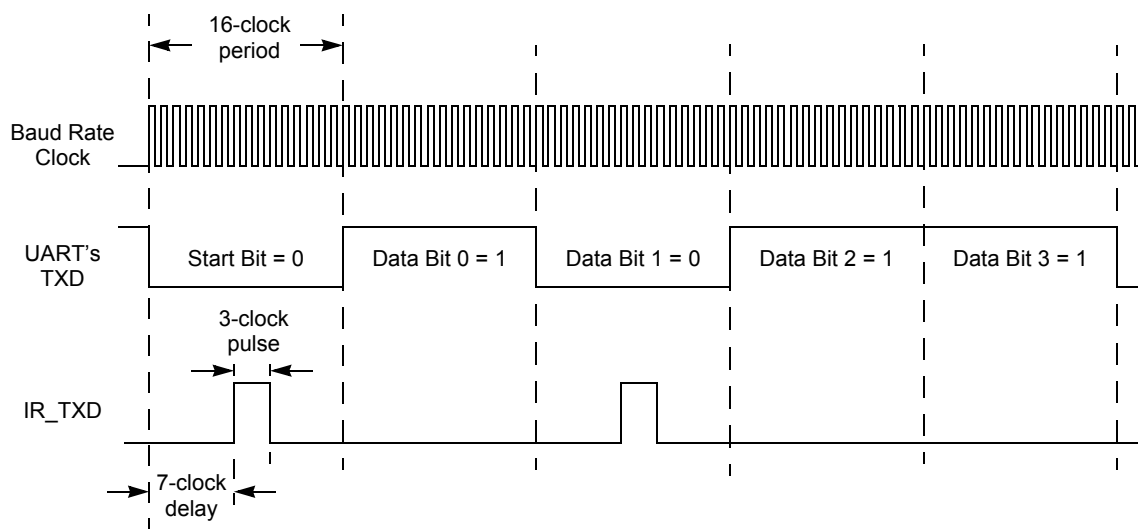

Figure 20. Infrared Data Transmission

Receiving IrDA Data

Data received from the infrared transceiver via the IR_RXD signal through the RXD pin is decoded by the Infrared Endec and passed to the UART. The UART's baud rate clock is used by the Infrared Endec to generate the demodulated signal (RXD) that drives the UART. Each UART/Infrared data bit is 16-clocks wide. Figure 21 displays data reception. When the Infrared Endec is enabled, the UART's RXD signal is internal to the 64K Series products while the IR_RXD signal is received through the RXD pin.

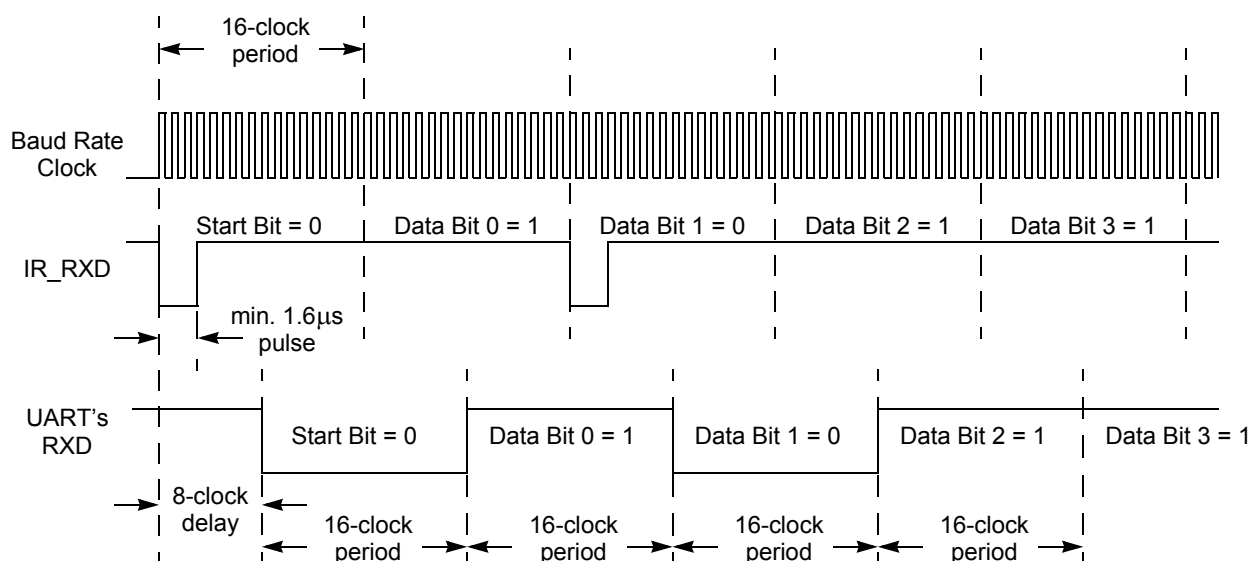

Figure 21. Infrared Data Reception



Caution: *The system clock frequency must be at least 1.0 MHz to ensure proper reception of the 1.6 µs minimum width pulses allowed by the IrDA standard.*

Endec Receiver Synchronization

The IrDA receiver uses a local baud rate clock counter (0 to 15 clock periods) to generate an input stream for the UART and to create a sampling window for detection of incoming pulses. The generated UART input (UART RXD) is delayed by 8 baud rate clock periods with respect to the incoming IrDA data stream. When a falling edge in the input data stream is detected, the Endec counter is reset. When the count reaches a value of 8, the UART RXD value is updated to reflect the value of the decoded data. When the count reaches 12 baud clock periods, the sampling window for the next incoming pulse opens. The window remains open until the count again reaches 8 (or in other words 24 baud clock periods since the previous pulse was detected). This gives the Endec a sampling window of minus four baudrate clocks to plus eight baudrate clocks around the expected time of an incoming pulse. If an incoming pulse is detected inside this window this process is

repeated. If the incoming data is a logical 1 (no pulse), the Endec returns to the initial state and waits for the next falling edge. As each falling edge is detected, the Endec clock counter is reset, resynchronizing the Endec to the incoming signal. This action allows the Endec to tolerate jitter and baud rate errors in the incoming data stream. Resynchronizing the Endec does not alter the operation of the UART, which ultimately receives the data. The UART is only synchronized to the incoming data stream when a Start bit is received.

Infrared Encoder/Decoder Control Register Definitions

All Infrared Endec configuration and status information is set by the UART control registers as defined in [UART Control Register Definitions](#) on page 114.



Caution: *To prevent spurious signals during IrDA data transmission, set the `IREN` bit in the `UARTx Control 1` register to 1 to enable the Infrared Encoder/Decoder before enabling the GPIO Port alternate function for the corresponding pin.*

Serial Peripheral Interface

Overview

The Serial Peripheral Interface is a synchronous interface allowing several SPI-type devices to be interconnected. SPI-compatible devices include EEPROMs, Analog-to-Digital Converters, and ISDN devices. Features of the SPI include:

- Full-duplex, synchronous, character-oriented communication
- Four-wire interface
- Data transfers rates up to a maximum of one-half the system clock frequency
- Error detection
- Dedicated Baud Rate Generator

Architecture

The SPI may be configured as either a Master (in single or multi-master systems) or a Slave as displayed in [Figure 22](#) through [Figure 24](#).

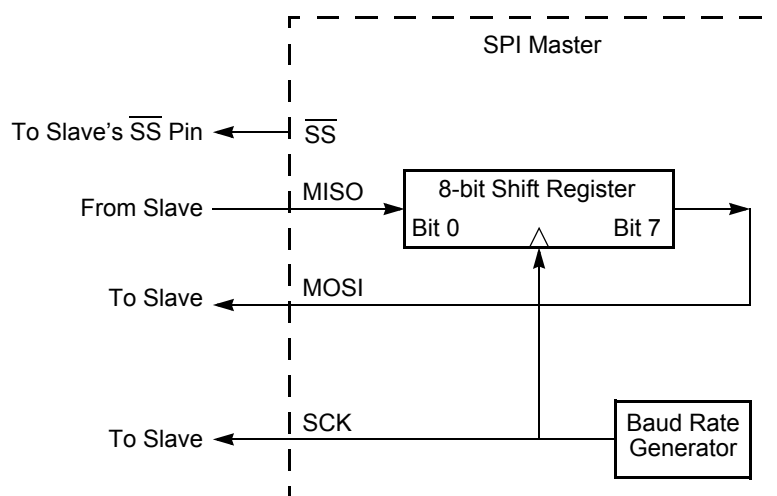

Figure 22. SPI Configured as a Master in a Single Master, Single Slave System

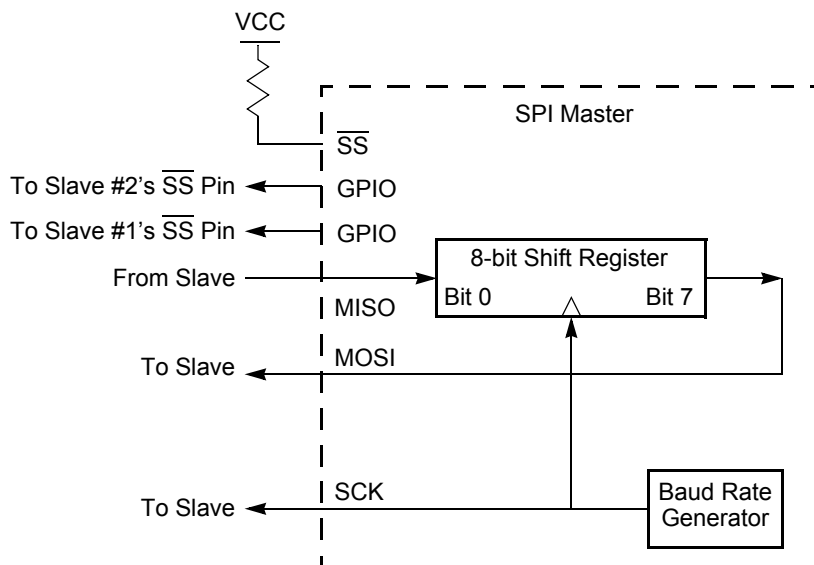

Figure 23. SPI Configured as a Master in a Single Master, Multiple Slave System

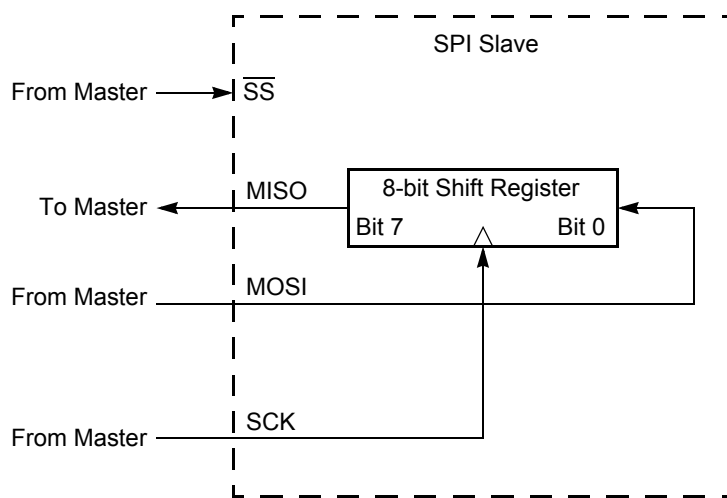

Figure 24. SPI Configured as a Slave

Operation

The SPI is a full-duplex, synchronous, character-oriented channel that supports a four-wire interface (serial clock, transmit, receive and Slave select). The SPI block consists of a transmit/receive shift register, a Baud Rate (clock) Generator and a control unit.

During an SPI transfer, data is sent and received simultaneously by both the Master and the Slave SPI devices. Separate signals are required for data and the serial clock. When an SPI transfer occurs, a multi-bit (typically 8-bit) character is shifted out one data pin and a multi-bit character is simultaneously shifted in on a second data pin. An 8-bit shift register in the Master and another 8-bit shift register in the Slave are connected as a circular buffer. The SPI shift register is single-buffered in the transmit and receive directions. New data to be transmitted cannot be written into the shift register until the previous transmission is complete and receive data (if valid) has been read.

SPI Signals

The four basic SPI signals are:

- [Master-In/Slave-Out](#)
- [Master-Out/Slave-In](#)
- [Serial Clock](#)
- [Slave Select](#)

Each signal is described in both Master and Slave modes.

Master-In/Slave-Out

The Master-In/Slave-Out (MISO) pin is configured as an input in a Master device and as an output in a Slave device. It is one of the two lines that transfer serial data, with the most significant bit sent first. The MISO pin of a Slave device is placed in a high-impedance state if the Slave is not selected. When the SPI is not enabled, this signal is in a high-impedance state.

Master-Out/Slave-In

The Master-Out/Slave-In (MOSI) pin is configured as an output in a Master device and as an input in a Slave device. It is one of the two lines that transfer serial data, with the most significant bit sent first. When the SPI is not enabled, this signal is in a high-impedance state.

Serial Clock

The Serial Clock (SCK) synchronizes data movement both in and out of the device through its MOSI and MISO pins. In MASTER mode, the SPI's Baud Rate Generator creates the serial clock. The Master drives the serial clock out its own SCK pin to the Slave's SCK pin. When the SPI is configured as a Slave, the SCK pin is an input and the clock signal from the Master synchronizes the data transfer between the Master and Slave devices. Slave devices ignore the SCK signal, unless the \overline{SS} pin is asserted. When configured as a slave, the SPI block requires a minimum SCK period of greater than or equal to 8 times the system (XIN) clock period.

The Master and Slave are each capable of exchanging a character of data during a sequence of NUMBITS clock cycles (see NUMBITS field in the [SPI Mode Register](#) on page 140). In both Master and Slave SPI devices, data is shifted on one edge of the SCK and is sampled on the opposite edge where data is stable. Edge polarity is determined by the SPI phase and polarity control.

Slave Select

The active Low Slave Select (\overline{SS}) input signal selects a Slave SPI device. \overline{SS} must be Low prior to all data communication to and from the Slave device. \overline{SS} must stay Low for the full duration of each character transferred. The \overline{SS} signal may stay Low during the transfer of multiple characters or may deassert between each character.

When the SPI is configured as the only Master in an SPI system, the \overline{SS} pin can be set as either an input or an output. For communication between the Z8F642x family Z8R642x family device's SPI Master and external Slave devices, the \overline{SS} signal, as an output, can assert the \overline{SS} input pin on one of the Slave devices. Other GPIO output pins can also be employed to select external SPI Slave devices.

When the SPI is configured as one Master in a multi-master SPI system, the \overline{SS} pin must be set as an input. The \overline{SS} input signal on the Master must be High. If the \overline{SS} signal goes Low (indicating another Master is driving the SPI bus), a Collision error Flag is set in the SPI Status register.

SPI Clock Phase and Polarity Control

The SPI supports four combinations of serial clock phase and polarity using two bits in the SPI Control register. The clock polarity bit, CLKPOL, selects an active high or active Low clock and has no effect on the transfer format. [Table 62](#) lists the SPI Clock Phase and Polarity Operation parameters. The clock phase bit, PHASE, selects one of two fundamentally different transfer formats. For proper data transmission, the clock phase and polarity must be identical for the SPI Master and the SPI Slave. The Master always places data on the MOSI line a half-cycle before the receive clock edge (SCK signal), in order for the Slave to latch the data.

Table 62. SPI Clock Phase (PHASE) and Clock Polarity (CLKPOL) Operation

PHASE	CLKPOL	SCK Transmit Edge	SCK Receive Edge	SCK Idle State
0	0	Falling	Rising	Low
0	1	Rising	Falling	High
1	0	Rising	Falling	Low
1	1	Falling	Rising	High

Transfer Format PHASE Equals Zero

Figure 25 displays the timing diagram for an SPI transfer in which PHASE is cleared to 0. The two SCK waveforms show polarity with CLKPOL reset to 0 and with CLKPOL set to one. The diagram may be interpreted as either a Master or Slave timing diagram because the SCK Master-In/Slave-Out (MISO) and Master-Out/Slave-In (MOSI) pins are directly connected between the Master and the Slave.

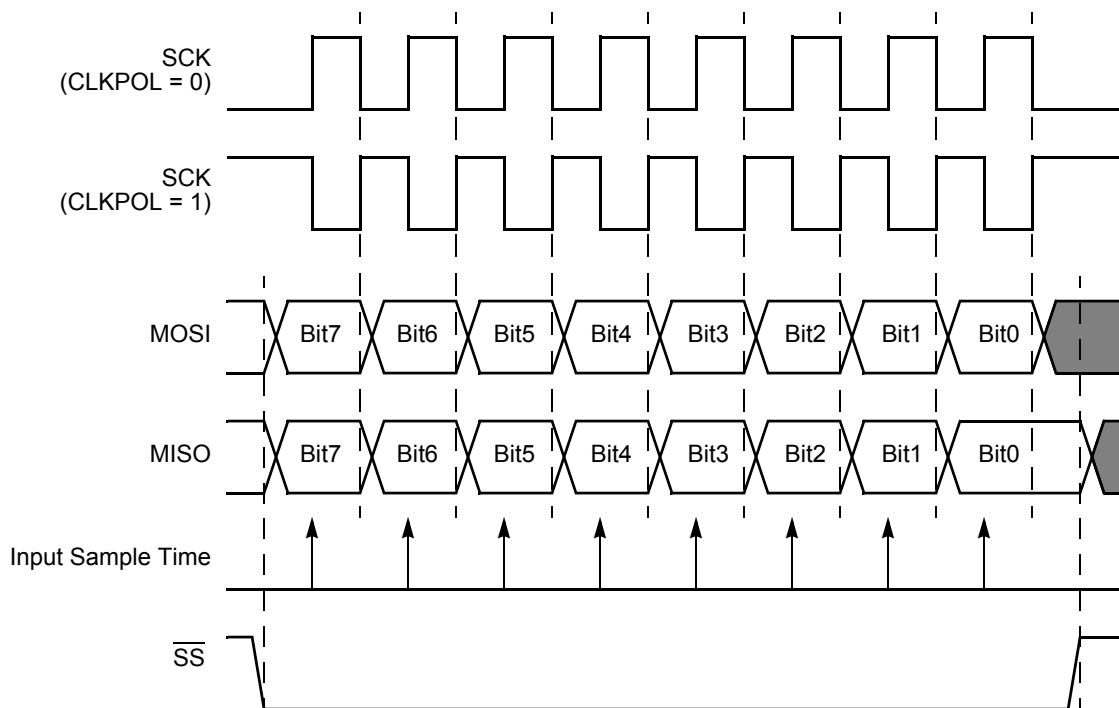

Figure 25. SPI Timing When PHASE is 0

Transfer Format PHASE Equals One

Figure 26 on page 134 displays the timing diagram for an SPI transfer in which PHASE is one. Two waveforms are depicted for SCK, one for CLKPOL reset to 0 and another for CLKPOL set to 1.

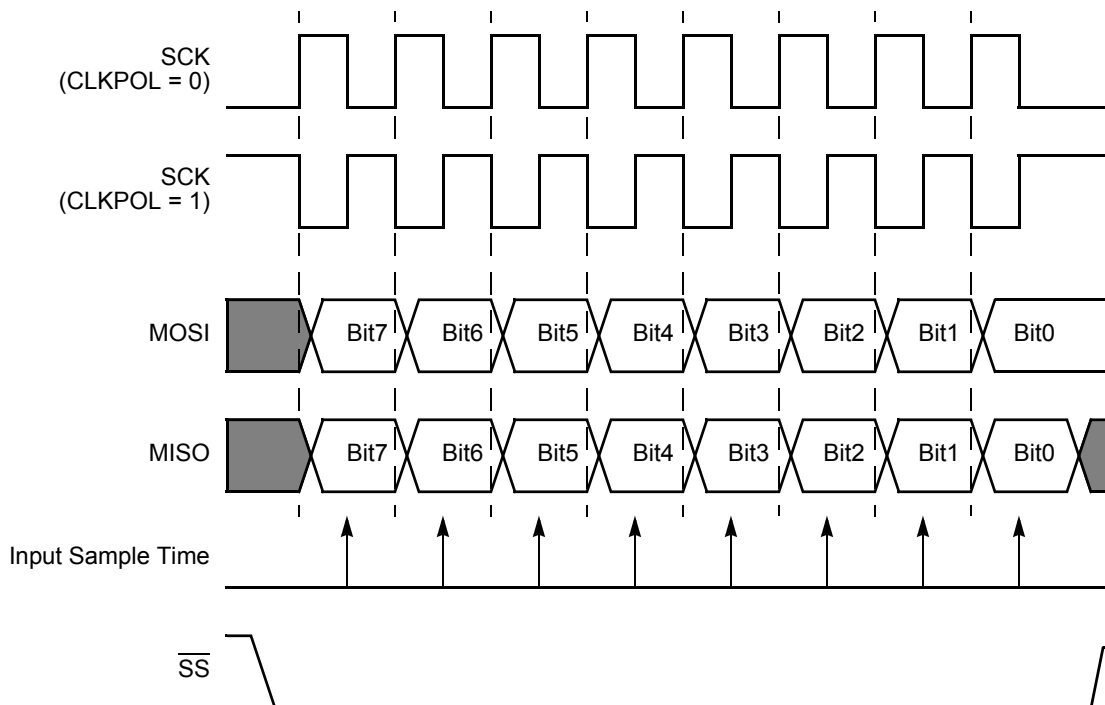

Figure 26. SPI Timing When PHASE is 1

Multi-Master Operation

In a multi-master SPI system, all SCK pins are tied together, all MOSI pins are tied together and all MISO pins are tied together. All SPI pins must then be configured in OPEN-DRAIN mode to prevent bus contention. At any one time, only one SPI device is configured as the Master and all other SPI devices on the bus are configured as Slaves. The Master enables a single Slave by asserting the \overline{SS} pin on that Slave only. Then, the single Master drives data out its SCK and MOSI pins to the SCK and MOSI pins on the Slaves (including those which are not enabled). The enabled Slave drives data out its MISO pin to the MISO Master pin.

For a Master device operating in a multi-master system, if the \overline{SS} pin is configured as an input and is driven Low by another Master, the COL bit is set to 1 in the SPI Status Register. The COL bit indicates the occurrence of a multi-master collision (mode fault error condition).

Slave Operation

The SPI block is configured for SLAVE mode operation by setting the SPIEN bit to 1 and the MMEN bit to 0 in the SPICTL register and setting the SSIO bit to 0 in the SPIMODE

register. The IRQE, PHASE, CLKPOL, WOR bits in the SPICTL register and the NUMBITS field in the SPIMODE register must be set to be consistent with the other SPI devices. The STR bit in the SPICTL register may be used if desired to force a “startup” interrupt. The BIRQ bit in the SPICTL register and the SSV bit in the SPIMODE register are not used in SLAVE mode. The SPI baud rate generator is not used in SLAVE mode so the SPIBRH and SPIBRL registers need not be initialized.

If the slave has data to send to the master, the data must be written to the SPIDAT register before the transaction starts (first edge of SCK when \overline{SS} is asserted). If the SPIDAT register is not written prior to the slave transaction, the MISO pin outputs whatever value is currently in the SPIDAT register.

Due to the delay resulting from synchronization of the SPI input signals to the internal system clock, the maximum SPICLK baud rate that can be supported in SLAVE mode is the system clock frequency (XIN) divided by 8. This rate is controlled by the SPI master.

Error Detection

The SPI contains error detection logic to support SPI communication protocols and recognize when communication errors have occurred. The SPI Status register indicates when a data transmission error has been detected.

Overrun (Write Collision)

An overrun error (write collision) indicates a write to the SPI Data register was attempted while a data transfer is in progress (in either MASTER or SLAVE modes). An overrun sets the OVR bit in the SPI Status register to 1. Writing a 1 to OVR clears this error Flag. The data register is not altered when a write occurs while data transfer is in progress.

Mode Fault (Multi-Master Collision)

A mode fault indicates when more than one Master is trying to communicate at the same time (a multi-master collision). The mode fault is detected when the enabled Master's \overline{SS} pin is asserted. A mode fault sets the COL bit in the SPI Status register to 1. Writing a 1 to COL clears this error Flag.

Slave Mode Abort

In SLAVE mode of operation if the \overline{SS} pin deasserts before all bits in a character have been transferred, the transaction is aborted. When this condition occurs the ABT bit is set in the SPISTAT register as well as the IRQ bit (indicating the transaction is complete). The next time \overline{SS} asserts, the MISO pin outputs SPIDAT[7], regardless of where the previous transaction left off. Writing a 1 to ABT clears this error Flag.

SPI Interrupts

When SPI interrupts are enabled, the SPI generates an interrupt after character transmission/reception completes in both MASTER and SLAVE modes. A character can be

defined to be 1 through 8 bits by the `NUMBITS` field in the SPI Mode register. In slave mode it is not necessary for `SS` to deassert between characters to generate the interrupt. The SPI in Slave mode can also generate an interrupt if the `SS` signal deasserts prior to transfer of all the bits in a character (see description of slave abort error above). Writing a 1 to the `IRQ` bit in the SPI Status Register clears the pending SPI interrupt request. The `IRQ` bit must be cleared to 0 by the Interrupt Service Routine to generate future interrupts. To start the transfer process, an SPI interrupt may be forced by software writing a 1 to the `STR` bit in the `SPICTL` register.

If the SPI is disabled, an SPI interrupt can be generated by a Baud Rate Generator time-out. This timer function must be enabled by setting the `BIRQ` bit in the `SPICTL` register. This Baud Rate Generator time-out does not set the `IRQ` bit in the `SPISTAT` register, just the SPI interrupt bit in the interrupt controller.

SPI Baud Rate Generator

In SPI Master mode, the Baud Rate Generator creates a lower frequency serial clock (`SCK`) for data transmission synchronization between the Master and the external Slave. The input to the Baud Rate Generator is the system clock. The SPI Baud Rate High and Low Byte registers combine to form a 16-bit reload value, `BRG[15:0]`, for the SPI Baud Rate Generator. The SPI baud rate is calculated using the following equation:

$$\text{SPI Baud Rate (bits/s)} = \frac{\text{System Clock Frequency (Hz)}}{2 \times \text{BRG}[15:0]}$$

Minimum baud rate is obtained by setting `BRG[15:0]` to `0000H` for a clock divisor value of $(2 \times 65536 = 131072)$.

When the SPI is disabled, the Baud Rate Generator can function as a basic 16-bit timer with interrupt on time-out. Follow the steps below to configure the Baud Rate Generator as a timer with interrupt on time-out:

1. Disable the SPI by clearing the `SPIEN` bit in the SPI Control register to 0.
2. Load the desired 16-bit count value into the SPI Baud Rate High and Low Byte registers.
3. Enable the Baud Rate Generator timer function and associated interrupt by setting the `BIRQ` bit in the SPI Control register to 1.

When configured as a general purpose timer, the interrupt interval is calculated using the following equation:

$$\text{Interrupt Interval (s)} = \text{System Clock Period (s)} \times \text{BRG}[15:0]$$



SPI Control Register Definitions

SPI Data Register

The SPI Data register (Table 63) stores both the outgoing (transmit) data and the incoming (receive) data. Reads from the SPI Data register always return the current contents of the 8-bit shift register. Data is shifted out starting with bit 7. The last bit received resides in bit position 0.

With the SPI configured as a Master, writing a data byte to this register initiates the data transmission. With the SPI configured as a Slave, writing a data byte to this register loads the shift register in preparation for the next data transfer with the external Master. In either the Master or Slave modes, if a transmission is already in progress, writes to this register are ignored and the Overrun error Flag, OVR, is set in the SPI Status register.

When the character length is less than 8 bits (as set by the NUMBITS field in the SPI Mode register), the transmit character must be left justified in the SPI Data register. A received character of less than 8 bits is right justified (last bit received is in bit position 0). For example, if the SPI is configured for 4-bit characters, the transmit characters must be written to SPIDATA[7:4] and the received characters are read from SPIDATA[3:0].

Table 63. SPI Data Register (SPIDATA)

BITS	7	6	5	4	3	2	1	0
FIELD	DATA							
RESET	X							
R/W	R/W							
ADDR	F60H							

DATA—Data
Transmit and/or receive data.

SPI Control Register

The SPI Control register (see Table 64 on page 138) configures the SPI for transmit and receive operations.

Table 64. SPI Control Register (SPICTL)

BITS	7	6	5	4	3	2	1	0
FIELD	IRQE	STR	BIRQ	PHASE	CLKPOL	WOR	MMEN	SPIEN
RESET	0							
R/W	R/W							
ADDR	F61H							

IRQE—Interrupt Request Enable

0 = SPI interrupts are disabled. No interrupt requests are sent to the Interrupt Controller.

1 = SPI interrupts are enabled. Interrupt requests are sent to the Interrupt Controller.

STR—Start an SPI Interrupt Request

0 = No effect.

1 = Setting this bit to 1 also sets the **IRQ** bit in the SPI Status register to 1. Setting this bit forces the SPI to send an interrupt request to the Interrupt Control. This bit can be used by software for a function similar to transmit buffer empty in a UART.

Writing a 1 to the **IRQ** bit in the SPI Status register clears this bit to 0.

BIRQ—BRG Timer Interrupt Request

If the SPI is enabled, this bit has no effect. If the SPI is disabled:

0 = The Baud Rate Generator timer function is disabled.

1 = The Baud Rate Generator timer function and time-out interrupt are enabled.

PHASE—Phase Select

Sets the phase relationship of the data to the clock. For more information on operation of the **PHASE** bit, see [SPI Clock Phase and Polarity Control](#) on page 132.

CLKPOL—Clock Polarity

0 = SCK idles Low (0).

1 = SCK idle High (1).

WOR—Wire-OR (OPEN-DRAIN) Mode Enabled

0 = SPI signal pins not configured for open-drain.

1 = All four SPI signal pins (SCK, \overline{SS} , MISO, MOSI) configured for open-drain function.

This setting is typically used for multi-master and/or multi-slave configurations.

MMEN—SPI Master Mode Enable

0 = SPI configured in Slave mode.

1 = SPI configured in Master mode.

SPIEN—SPI Enable

0 = SPI disabled.

1 = SPI enabled.

SPI Status Register

The SPI Status register (Table 65) indicates the current state of the SPI. All bits revert to their reset state if the SPIEN bit in the SPICTL register = 0.

Table 65. SPI Status Register (SPISTAT)

BITS	7	6	5	4	3	2	1	0
FIELD	IRQ	OVR	COL	ABT	Reserved		TXST	SLAS
RESET	0							1
R/W	R/W*				R			
ADDR	F62H							
Note: R/W* = Read access. Write a 1 to clear the bit to 0.								

IRQ—Interrupt Request

If SPIEN = 1, this bit is set if the STR bit in the SPICTL register is set, or upon completion of an SPI master or slave transaction. This bit does not set if SPIEN = 0 and the SPI Baud Rate Generator is used as a timer to generate the SPI interrupt.

0 = No SPI interrupt request pending.

1 = SPI interrupt request is pending.

OVR—Overrun

0 = An overrun error has not occurred.

1 = An overrun error has been detected.

COL—Collision

0 = A multi-master collision (mode fault) has not occurred.

1 = A multi-master collision (mode fault) has been detected.

ABT—Slave mode transaction abort

This bit is set if the SPI is configured in slave mode, a transaction is occurring and \overline{SS} deasserts before all bits of a character have been transferred as defined by the NUMBITS field of the SPIMODE register. The IRQ bit also sets, indicating the transaction has completed.

0 = A slave mode transaction abort has not occurred.

1 = A slave mode transaction abort has been detected.

Reserved—Must be 0.

TXST—Transmit Status

0 = No data transmission currently in progress.

1 = Data transmission currently in progress.

SLAS—Slave Select

If SPI enabled as a Slave,

0 = \overline{SS} input pin is asserted (Low).
 1 = \overline{SS} input is not asserted (High).
 If SPI enabled as a Master, this bit is not applicable.

SPI Mode Register

The SPI Mode register (Table 66) configures the character bit width and the direction and value of the \overline{SS} pin.

Table 66. SPI Mode Register (SPIMODE)

BITS	7	6	5	4	3	2	1	0
FIELD	Reserved		DIAG	NUMBITS[2:0]			SSIO	SSV
RESET	0							
R/W	R		R/W					
ADDR	F63H							

Reserved—Must be 0.

DIAG—Diagnostic Mode Control bit

This bit is for SPI diagnostics. Setting this bit allows the Baud Rate Generator value to be read using the SPIBRH and SPIBRL register locations.

0 = Reading SPIBRH, SPIBRL returns the value in the SPIBRH and SPIBRL registers

1 = Reading SPIBRH returns bits [15:8] of the SPI Baud Rate Generator; and reading SPIBRL returns bits [7:0] of the SPI Baud Rate Counter. The Baud Rate Counter High and Low byte values are not buffered.



Caution: Exercise caution if reading the values while the BRG is counting.

NUMBITS[2:0]—Number of Data Bits Per Character to Transfer

This field contains the number of bits to shift for each character transfer. For information on valid bit positions when the character length is less than 8-bits, see SPI Data Register description.

- 000 = 8 bits
- 001 = 1 bit
- 010 = 2 bits
- 011 = 3 bits
- 100 = 4 bits
- 101 = 5 bits
- 110 = 6 bits
- 111 = 7 bits

SSIO—Slave Select I/O

0 = \overline{SS} pin configured as an input.

1 = \overline{SS} pin configured as an output (Master mode only).

SSV—Slave Select Value

If SSIO = 1 and SPI configured as a Master:

0 = \overline{SS} pin driven Low (0).

1 = \overline{SS} pin driven High (1).

This bit has no effect if SSIO = 0 or SPI configured as a Slave.

SPI Diagnostic State Register

The SPI Diagnostic State register (Table 67) provides observability of internal state. This is a read only register used for SPI diagnostics.

Table 67. SPI Diagnostic State Register (SPIDST)

BITS	7	6	5	4	3	2	1	0
FIELD	SCKEN	TCKEN	SPISTATE					
RESET	0							
R/W	R							
ADDR	F64H							

SCKEN—Shift Clock Enable

0 = The internal Shift Clock Enable signal is deasserted

1 = The internal Shift Clock Enable signal is asserted (shift register is updates on next system clock)

TCKEN—Transmit Clock Enable

0 = The internal Transmit Clock Enable signal is deasserted.

1 = The internal Transmit Clock Enable signal is asserted. When this is asserted the serial data out is updated on the next system clock (MOSI or MISO).

SPISTATE—SPI State Machine

Defines the current state of the internal SPI State Machine.

SPI Baud Rate High and Low Byte Registers

The SPI Baud Rate High and Low Byte registers (Table 68 and Table 69) combine to form a 16-bit reload value, BRG[15:0], for the SPI Baud Rate Generator.

When configured as a general purpose timer, the SPI BRG interrupt interval is calculated using the following equation:

$$\text{SPI BRG Interrupt Interval (s)} = \text{System Clock Period (s)} \times \text{BRG}[15:0]$$

Table 68. SPI Baud Rate High Byte Register (SPIBRH)

BITS	7	6	5	4	3	2	1	0
FIELD	BRH							
RESET	1							
R/W	R/W							
ADDR	F66H							

BRH = SPI Baud Rate High Byte
Most significant byte, BRG[15:8], of the SPI Baud Rate Generator's reload value.

Table 69. SPI Baud Rate Low Byte Register (SPIBRL)

BITS	7	6	5	4	3	2	1	0
FIELD	BRL							
RESET	1							
R/W	R/W							
ADDR	F67H							

BRL = SPI Baud Rate Low Byte
Least significant byte, BRG[7:0], of the SPI Baud Rate Generator's reload value.

I²C Controller

Overview

The I²C Controller makes the 64K Series products bus-compatible with the I²C protocol. The I²C Controller consists of two bidirectional bus lines—a serial data signal (SDA) and a serial clock signal (SCL). Features of the I²C Controller include:

- Transmit and Receive Operation in MASTER mode
- Maximum data rate of 400 kbit/sec
- 7- and 10-bit addressing modes for Slaves
- Unrestricted number of data bytes transmitted per transfer

The I²C Controller in the 64K Series products does not operate in SLAVE mode.

Architecture

Figure 27 displays the architecture of the I²C Controller.

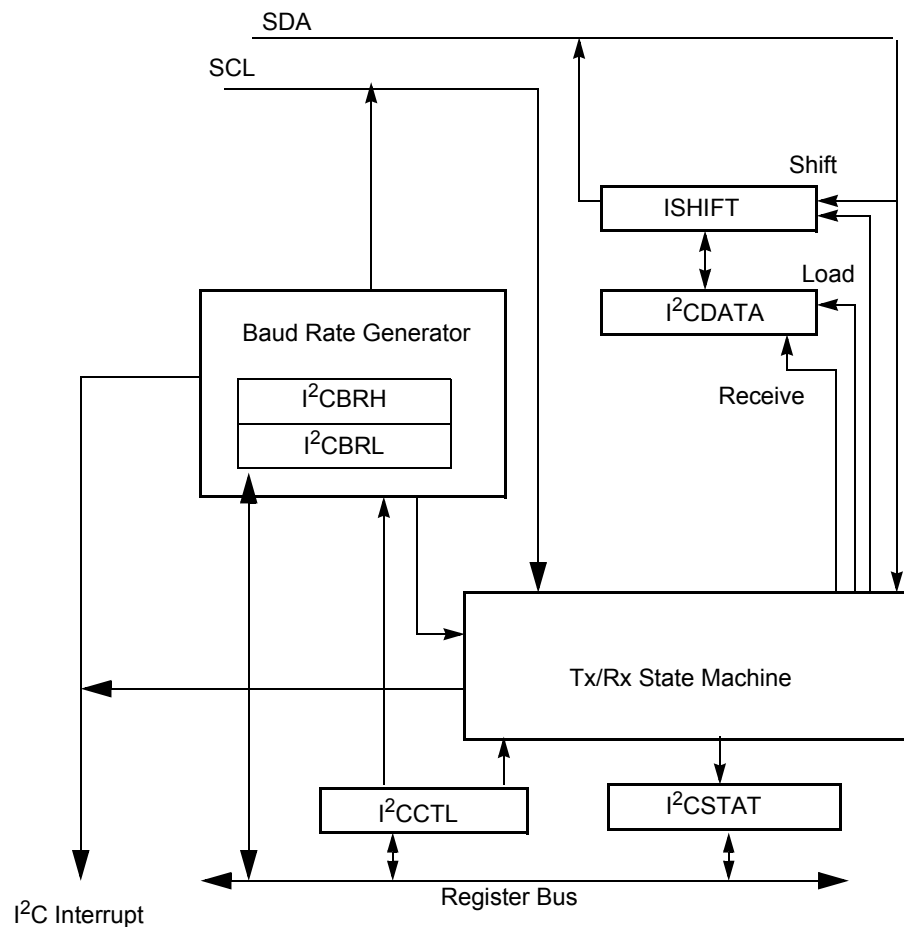

Figure 27. I²C Controller Block Diagram

Operation

The I²C Controller operates in MASTER mode to transmit and receive data. Only a single master is supported. Arbitration between two masters must be accomplished in software. I²C supports the following operations:

- Master transmits to a 7-bit slave
- Master transmits to a 10-bit slave

- Master receives from a 7-bit slave
- Master receives from a 10-bit slave

SDA and SCL Signals

I²C sends all addresses, data and acknowledge signals over the SDA line, most-significant bit first. SCL is the common clock for the I²C Controller. When the SDA and SCL pin alternate functions are selected for their respective GPIO ports, the pins are automatically configured for open-drain operation.

The master (I²C) is responsible for driving the SCL clock signal, although the clock signal can become skewed by a slow slave device. During the low period of the clock, the slave pulls the SCL signal Low to suspend the transaction. The master releases the clock at the end of the low period and notices that the clock remains low instead of returning to a high level. When the slave releases the clock, the I²C Controller continues the transaction. All data is transferred in bytes and there is no limit to the amount of data transferred in one operation. When transmitting data or acknowledging read data from the slave, the SDA signal changes in the middle of the low period of SCL and is sampled in the middle of the high period of SCL.

I²C Interrupts

The I²C Controller contains four sources of interrupts—Transmit, Receive, Not Acknowledge and baud rate generator. These four interrupt sources are combined into a single interrupt request signal to the Interrupt Controller. The Transmit interrupt is enabled by the IEN and TXI bits of the Control register. The Receive and Not Acknowledge interrupts are enabled by the IEN bit of the Control register. The baud rate generator interrupt is enabled by the BIRQ and IEN bits of the Control register.

Not Acknowledge interrupts occur when a Not Acknowledge condition is received from the slave or sent by the I²C Controller and neither the *START* or *STOP* bit is set. The Not Acknowledge event sets the NCKI bit of the I²C Status register and can only be cleared by setting the *START* or *STOP* bit in the I²C Control register. When this interrupt occurs, the I²C Controller waits until either the *STOP* or *START* bit is set before performing any action. In an interrupt service routine, the NCKI bit should always be checked prior to servicing transmit or receive interrupt conditions because it indicates the transaction is being terminated.

Receive interrupts occur when a byte of data has been received by the I²C Controller (master reading data from slave). This procedure sets the RDRF bit of the I²C Status register. The RDRF bit is cleared by reading the I²C Data register. The RDRF bit is set during the acknowledge phase. The I²C Controller pauses after the acknowledge phase until the receive interrupt is cleared before performing any other action.

Transmit interrupts occur when the TDRE bit of the I²C Status register sets and the TXI bit in the I²C Control register is set. Transmit interrupts occur under the following conditions when the transmit data register is empty:

- The I²C Controller is enabled.
- The first bit of the byte of an address is shifting out and the RD bit of the I²C Status register is deasserted.
- The first bit of a 10-bit address shifts out.
- The first bit of write data shifts out.

► **Note:** *Writing to the I²C Data register always clears the TRDE bit to 0. When TDRE is asserted, the I²C Controller pauses at the beginning of the Acknowledge cycle of the byte currently shifting out until the Data register is written with the next value to send or the STOP or START bits are set indicating the current byte is the last one to send.*

The fourth interrupt source is the baud rate generator. If the I²C Controller is disabled (IEN bit in the I2CCTL register = 0) and the BIRQ bit in the I2CCTL register = 1, an interrupt is generated when the baud rate generator counts down to 1. This allows the I²C baud rate generator to be used by software as a general purpose timer when IEN = 0.

Software Control of I²C Transactions

Software can control I²C transactions by using the I²C Controller interrupt, by polling the I²C Status register or by DMA. Note that not all products include a DMA Controller.

To use interrupts, the I²C interrupt must be enabled in the Interrupt Controller. The TXI bit in the I²C Control register must be set to enable transmit interrupts.

To control transactions by polling, the interrupt bits (TDRE, RDRF and NCKI) in the I²C Status register should be polled. The TDRE bit asserts regardless of the state of the TXI bit.

Either or both transmit and receive data movement can be controlled by the DMA Controller. The DMA Controller channel(s) must be initialized to select the I²C transmit and receive requests. Transmit DMA requests require that the TXI bit in the I²C Control register be set.



Caution: *A transmit (write) DMA operation hangs if the slave responds with a Not Acknowledge before the last byte has been sent. After receiving the Not Acknowledge, the I²C Controller sets the NCKI bit in the Status register and pauses until either the STOP or START bits in the Control register are set.*

In order for a receive (read) DMA transaction to send a Not Acknowledge on the last byte, the receive DMA must be set up to receive n-1 bytes, then software must set the NAK bit and receive the last (nth) byte directly.

Start and Stop Conditions

The master (I²C) drives all Start and Stop signals and initiates all transactions. To start a transaction, the I²C Controller generates a START condition by pulling the SDA signal Low while SCL is High. To complete a transaction, the I²C Controller generates a Stop condition by creating a low-to-high transition of the SDA signal while the SCL signal is high. The START and STOP bits in the I²C Control register control the sending of the Start and Stop conditions. A master is also allowed to end one transaction and begin a new one by issuing a Restart. This is accomplished by setting the START bit at the end of a transaction, rather than the STOP bit. Note that the Start condition not sent until the START bit is set and data has been written to the I²C Data register.

Master Write and Read Transactions

The following sections provide a recommended procedure for performing I²C write and read transactions from the I²C Controller (master) to slave I²C devices. In general software should rely on the TDRE, RDRF and NCKI bits of the status register (these bits generate interrupts) to initiate software actions. When using interrupts or DMA, the TXI bit is set to start each transaction and cleared at the end of each transaction to eliminate a ‘trailing’ Transmit interrupt.

Caution should be used in using the ACK status bit within a transaction because it is difficult for software to tell when it is updated by hardware.

When writing data to a slave, the I²C pauses at the beginning of the Acknowledge cycle if the data register has not been written with the next value to be sent (TDRE bit in the I²C Status register = 1). In this scenario where software is not keeping up with the I²C bus (TDRE asserted longer than one byte time), the Acknowledge clock cycle for byte n is delayed until the Data register is written with byte n + 1, and appears to be grouped with the data clock cycles for byte n+1. If either the START or STOP bit is set, the I²C does not pause prior to the Acknowledge cycle because no additional data is sent.

When a Not Acknowledge condition is received during a write (either during the address or data phases), the I²C Controller generates the Not Acknowledge interrupt (NCKI = 1) and pause until either the STOP or START bit is set. Unless the Not Acknowledge was received on the last byte, the Data register will already have been written with the next address or data byte to send. In this case the FLUSH bit of the Control register should be set at the same time the STOP or START bit is set to remove the stale transmit data and enable subsequent Transmit interrupts.

When reading data from the slave, the I²C pauses after the data Acknowledge cycle until the receive interrupt is serviced and the RDRF bit of the status register is cleared by

reading the I²C Data register. Once the I²C data register has been read, the I²C reads the next data byte.

Address Only Transaction with a 7-bit Address

In the situation where software determines if a slave with a 7-bit address is responding without sending or receiving data, a transaction can be done which only consists of an address phase. Figure 28 displays this ‘address only’ transaction to determine if a slave with a 7-bit address will acknowledge. As an example, this transaction can be used after a ‘write’ has been done to a EEPROM to determine when the EEPROM completes its internal write operation and is once again responding to I²C transactions. If the slave does not Acknowledge, the transaction can be repeated until the slave does Acknowledge.

S	Slave Address	W = 0	A/ \bar{A}	P
---	---------------	-------	--------------	---

Figure 28. 7-Bit Address Only Transaction Format

Follow the steps below for an address only transaction to a 7-bit addressed slave:

1. Software asserts the IEN bit in the I²C Control register.
2. Software asserts the TXI bit of the I²C Control register to enable Transmit interrupts.
3. The I²C interrupt asserts, because the I²C Data register is empty (TDRE = 1)
4. Software responds to the TDRE bit by writing a 7-bit slave address plus write bit (=0) to the I²C Data register. As an alternative this could be a read operation instead of a write operation.
5. Software sets the START and STOP bits of the I²C Control register and clears the TXI bit.
6. The I²C Controller sends the START condition to the I²C slave.
7. The I²C Controller loads the I²C Shift register with the contents of the I²C Data register.
8. Software polls the STOP bit of the I²C Control register. Hardware deasserts the STOP bit when the address only transaction is completed.
9. Software checks the ACK bit of the I²C Status register. If the slave acknowledged, the ACK bit is = 1. If the slave does not acknowledge, the ACK bit is = 0. The NCKI interrupt does not occur in the not acknowledge case because the STOP bit was set.

Write Transaction with a 7-Bit Address

Figure 29 displays the data transfer format for a 7-bit addressed slave. Shaded regions indicate data transferred from the I²C Controller to slaves and unshaded regions indicate data transferred from the slaves to the I²C Controller.

S	Slave Address	W = 0	A	Data	A	Data	A	Data	$\overline{A/A}$	P/S
---	---------------	-------	---	------	---	------	---	------	------------------	-----

Figure 29. 7-Bit Addressed Slave Data Transfer Format

Follow the steps below for a transmit operation to a 7-bit addressed slave:

1. Software asserts the IEN bit in the I²C Control register.
2. Software asserts the TXI bit of the I²C Control register to enable Transmit interrupts.
3. The I²C interrupt asserts, because the I²C Data register is empty
4. Software responds to the TDRE bit by writing a 7-bit slave address plus write bit (=0) to the I²C Data register.
5. Software asserts the START bit of the I²C Control register.
6. The I²C Controller sends the START condition to the I²C slave.
7. The I²C Controller loads the I²C Shift register with the contents of the I²C Data register.
8. After one bit of address has been shifted out by the SDA signal, the Transmit interrupt is asserted (TDRE = 1).
9. Software responds by writing the transmit data into the I²C Data register.
10. The I²C Controller shifts the rest of the address and write bit out by the SDA signal.
11. If the I²C slave sends an acknowledge (by pulling the SDA signal low) during the next high period of SCL the I²C Controller sets the ACK bit in the I²C Status register. Continue with [step 12](#).

If the slave does not acknowledge, the Not Acknowledge interrupt occurs (NCKI bit is set in the Status register, ACK bit is cleared). Software responds to the Not Acknowledge interrupt by setting the STOP and FLUSH bits and clearing the TXI bit. The I²C Controller sends the STOP condition on the bus and clears the STOP and NCKI bits. The transaction is complete (ignore the following steps).

12. The I²C Controller loads the contents of the I²C Shift register with the contents of the I²C Data register.

13. The I²C Controller shifts the data out of using the SDA signal. After the first bit is sent, the Transmit interrupt is asserted.
14. If more bytes remain to be sent, return to [step 9](#).
15. Software responds by setting the STOP bit of the I²C Control register (or START bit to initiate a new transaction). In the STOP case, software clears the TXI bit of the I²C Control register at the same time.
16. The I²C Controller completes transmission of the data on the SDA signal.
17. The slave may either Acknowledge or Not Acknowledge the last byte. Because either the STOP or START bit is already set, the NCKI interrupt does not occur.
18. The I²C Controller sends the STOP (or RESTART) condition to the I²C bus. The STOP or START bit is cleared.

Address Only Transaction with a 10-bit Address

In the situation where software wants to determine if a slave with a 10-bit address is responding without sending or receiving data, a transaction can be done which only consists of an address phase. [Figure 30](#) displays this ‘address only’ transaction to determine if a slave with 10-bit address will acknowledge. As an example, this transaction can be used after a ‘write’ has been done to a EEPROM to determine when the EEPROM completes its internal write operation and is once again responding to I²C transactions. If the slave does not Acknowledge the transaction can be repeated until the slave is able to Acknowledge.

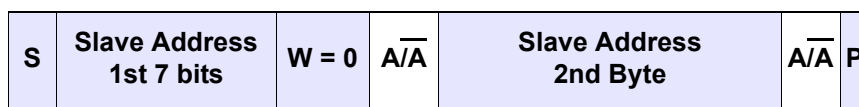

Figure 30. 10-Bit Address Only Transaction Format

Follow the steps below for an address only transaction to a 10-bit addressed slave:

1. Software asserts the IEN bit in the I²C Control register.
2. Software asserts the TXI bit of the I²C Control register to enable Transmit interrupts.
3. The I²C interrupt asserts, because the I²C Data register is empty (TDRE = 1)
4. Software responds to the TDRE interrupt by writing the first slave address byte. The least-significant bit must be 0 for the write operation.
5. Software asserts the START bit of the I²C Control register.
6. The I²C Controller sends the START condition to the I²C slave.

7. The I²C Controller loads the I²C Shift register with the contents of the I²C Data register.
8. After one bit of address is shifted out by the SDA signal, the Transmit interrupt is asserted.
9. Software responds by writing the second byte of address into the contents of the I²C Data register.
10. The I²C Controller shifts the rest of the first byte of address and write bit out the SDA signal.
11. If the I²C slave sends an acknowledge by pulling the SDA signal low during the next high period of SCL the I²C Controller sets the ACK bit in the I²C Status register. Continue with [step 12](#).

If the slave does not acknowledge the first address byte, the I²C Controller sets the NCKI bit and clears the ACK bit in the I²C Status register. Software responds to the Not Acknowledge interrupt by setting the STOP and FLUSH bits and clearing the TXI bit. The I²C Controller sends the STOP condition on the bus and clears the STOP and NCKI bits. The transaction is complete (ignore following steps).

12. The I²C Controller loads the I²C Shift register with the contents of the I²C Data register (2nd byte of address).
13. The I²C Controller shifts the second address byte out the SDA signal. After the first bit has been sent, the Transmit interrupt is asserted.
14. Software responds by setting the STOP bit in the I²C Control register. The TXI bit can be cleared at the same time.
15. Software polls the STOP bit of the I²C Control register. Hardware deasserts the STOP bit when the transaction is completed (STOP condition has been sent).
16. Software checks the ACK bit of the I²C Status register. If the slave acknowledged, the ACK bit is = 1. If the slave does not acknowledge, the ACK bit is = 0. The NCKI interrupt do not occur because the STOP bit was set.

Write Transaction with a 10-Bit Address

[Figure 31](#) displays the data transfer format for a 10-bit addressed slave. Shaded regions indicate data transferred from the I²C Controller to slaves and unshaded regions indicate data transferred from the slaves to the I²C Controller.

S	Slave Address 1st 7 bits	W = 0	A	Slave Address 2nd Byte	A	Data	A	Data	A/A	P/S
---	-----------------------------	-------	---	---------------------------	---	------	---	------	-----	-----

Figure 31. 10-Bit Addressed Slave Data Transfer Format

The first seven bits transmitted in the first byte are 11110xx. The two bits xx are the two most-significant bits of the 10-bit address. The lowest bit of the first byte transferred is the read/write control bit (=0). The transmit operation is carried out in the same manner as 7-bit addressing.

Follow the steps below for a transmit operation on a 10-bit addressed slave:

1. Software asserts the IEN bit in the I²C Control register.
2. Software asserts the TXI bit of the I²C Control register to enable Transmit interrupts.
3. The I²C interrupt asserts because the I²C Data register is empty.
4. Software responds to the TDRE interrupt by writing the first slave address byte to the I²C Data register. The least-significant bit must be 0 for the write operation.
5. Software asserts the START bit of the I²C Control register.
6. The I²C Controller sends the START condition to the I²C slave.
7. The I²C Controller loads the I²C Shift register with the contents of the I²C Data register.
8. After one bit of address is shifted out by the SDA signal, the Transmit interrupt is asserted.
9. Software responds by writing the second byte of address into the contents of the I²C Data register.
10. The I²C Controller shifts the rest of the first byte of address and write bit out the SDA signal.
11. If the I²C slave acknowledges the first address byte by pulling the SDA signal low during the next high period of SCL, the I²C Controller sets the ACK bit in the I²C Status register. Continue with [step 12](#).

If the slave does not acknowledge the first address byte, the I²C Controller sets the NCKI bit and clears the ACK bit in the I²C Status register. Software responds to the Not Acknowledge interrupt by setting the STOP and FLUSH bits and clearing the TXI bit. The I²C Controller sends the STOP condition on the bus and clears the STOP and NCKI bits. The transaction is complete (ignore the following steps).

12. The I²C Controller loads the I²C Shift register with the contents of the I²C Data register.
13. The I²C Controller shifts the second address byte out the SDA signal. After the first bit has been sent, the Transmit interrupt is asserted.
14. Software responds by writing a data byte to the I²C Data register.
15. The I²C Controller completes shifting the contents of the shift register on the SDA signal.

16. If the I²C slave sends an acknowledge by pulling the SDA signal low during the next high period of SCL, the I²C Controller sets the ACK bit in the I²C Status register. Continue with [step 17](#).

If the slave does not acknowledge the second address byte or one of the data bytes, the I²C Controller sets the NCKI bit and clears the ACK bit in the I²C Status register. Software responds to the Not Acknowledge interrupt by setting the STOP and FLUSH bits and clearing the TXI bit. The I²C Controller sends the STOP condition on the bus and clears the STOP and NCKI bits. The transaction is complete (ignore the following steps).

17. The I²C Controller shifts the data out by the SDA signal. After the first bit is sent, the Transmit interrupt is asserted.
18. If more bytes remain to be sent, return to [step 14](#).
19. If the last byte is currently being sent, software sets the STOP bit of the I²C Control register (or START bit to initiate a new transaction). In the STOP case, software also clears the TXI bit of the I²C Control register at the same time.
20. The I²C Controller completes transmission of the last data byte on the SDA signal.
21. The slave may either Acknowledge or Not Acknowledge the last byte. Because either the STOP or START bit is already set, the NCKI interrupt does not occur.
22. The I²C Controller sends the STOP (or RESTART) condition to the I²C bus and clears the STOP (or START) bit.

Read Transaction with a 7-Bit Address

[Figure 32](#) displays the data transfer format for a read operation to a 7-bit addressed slave. The shaded regions indicate data transferred from the I²C Controller to slaves and unshaded regions indicate data transferred from the slaves to the I²C Controller.

S	Slave Address	R = 1	A	Data	A	Data	\bar{A}	P/S
---	---------------	-------	---	------	---	------	-----------	-----

Figure 32. Receive Data Transfer Format for a 7-Bit Addressed Slave

Follow the steps below for a read operation to a 7-bit addressed slave:

1. Software writes the I²C Data register with a 7-bit slave address plus the read bit (=1).
2. Software asserts the START bit of the I²C Control register.
3. If this is a single byte transfer, Software asserts the NAK bit of the I²C Control register so that after the first byte of data has been read by the I²C Controller, a Not Acknowledge is sent to the I²C slave.

4. The I²C Controller sends the START condition.
5. The I²C Controller shifts the address and read bit out the SDA signal.
6. If the I²C slave acknowledges the address by pulling the SDA signal Low during the next high period of SCL, the I²C Controller sets the ACK bit in the I²C Status register. Continue with [step 7](#).

If the slave does not acknowledge, the Not Acknowledge interrupt occurs (NCKI bit is set in the Status register, ACK bit is cleared). Software responds to the Not Acknowledge interrupt by setting the STOP bit and clearing the TXI bit. The I²C Controller sends the STOP condition on the bus and clears the STOP and NCKI bits. The transaction is complete (ignore the following steps).

7. The I²C Controller shifts in the byte of data from the I²C slave on the SDA signal. The I²C Controller sends a Not Acknowledge to the I²C slave if the NAK bit is set (last byte), else it sends an Acknowledge.
8. The I²C Controller asserts the Receive interrupt (RDRF bit set in the Status register).
9. Software responds by reading the I²C Data register which clears the RDRF bit. If there is only one more byte to receive, set the NAK bit of the I²C Control register.
10. If there are more bytes to transfer, return to [step 7](#).
11. After the last byte is shifted in, a Not Acknowledge interrupt is generated by the I²C Controller.
12. Software responds by setting the STOP bit of the I²C Control register.
13. A STOP condition is sent to the I²C slave, the STOP and NCKI bits are cleared.

Read Transaction with a 10-Bit Address

[Figure 33](#) displays the read transaction format for a 10-bit addressed slave. The shaded regions indicate data transferred from the I²C Controller to slaves and unshaded regions indicate data transferred from the slaves to the I²C Controller.

S	Slave Address 1st 7 bits	W=0	A	Slave Address 2nd Byte	A	S	Slave Address 1st 7 bits	R=1	A	Data	A	Data	\bar{A}	P
---	-----------------------------	-----	---	---------------------------	---	---	-----------------------------	-----	---	------	---	------	-----------	---

Figure 33. Receive Data Format for a 10-Bit Addressed Slave

The first seven bits transmitted in the first byte are 11110xx. The two bits xx are the two most-significant bits of the 10-bit address. The lowest bit of the first byte transferred is the write control bit.

Follow the steps below for the data transfer for a read operation to a 10-bit addressed slave:

1. Software writes 11110B followed by the two address bits and a 0 (write) to the I²C Data register.
2. Software asserts the START and TXI bits of the I²C Control register.
3. The I²C Controller sends the Start condition.
4. The I²C Controller loads the I²C Shift register with the contents of the I²C Data register.
5. After the first bit has been shifted out, a Transmit interrupt is asserted.
6. Software responds by writing the lower eight bits of address to the I²C Data register.
7. The I²C Controller completes shifting of the two address bits and a 0 (write).
8. If the I²C slave acknowledges the first address byte by pulling the SDA signal low during the next high period of SCL, the I²C Controller sets the ACK bit in the I²C Status register. Continue with [step 9](#).

If the slave does not acknowledge the first address byte, the I²C Controller sets the NCKI bit and clears the ACK bit in the I²C Status register. Software responds to the Not Acknowledge interrupt by setting the STOP and FLUSH bits and clearing the TXI bit. The I²C Controller sends the STOP condition on the bus and clears the STOP and NCKI bits. The transaction is complete (ignore following steps).

9. The I²C Controller loads the I²C Shift register with the contents of the I²C Data register (second address byte).
10. The I²C Controller shifts out the second address byte. After the first bit is shifted, the I²C Controller generates a Transmit interrupt.
11. Software responds by setting the START bit of the I²C Control register to generate a repeated START and by clearing the TXI bit.
12. Software responds by writing 11110B followed by the 2-bit slave address and a 1 (read) to the I²C Data register.
13. If only one byte is to be read, software sets the NAK bit of the I²C Control register.
14. After the I²C Controller shifts out the 2nd address byte, the I²C slave sends an acknowledge by pulling the SDA signal low during the next high period of SCL, the I²C Controller sets the ACK bit in the I²C Status register. Continue with [step 15](#).

If the slave does not acknowledge the second address byte, the I²C Controller sets the NCKI bit and clears the ACK bit in the I²C Status register. Software responds to the Not Acknowledge interrupt by setting the STOP and FLUSH bits and clearing the TXI bit. The I²C Controller sends the STOP condition on the bus and clears the STOP and NCKI bits. The transaction is complete (ignore the following steps).

15. The I²C Controller sends the repeated START condition.
16. The I²C Controller loads the I²C Shift register with the contents of the I²C Data register (third address transfer).
17. The I²C Controller sends 11110B followed by the two most significant bits of the slave read address and a 1 (read).
18. The I²C slave sends an acknowledge by pulling the SDA signal Low during the next high period of SCL

If the slave were to Not Acknowledge at this point (this should not happen because the slave did acknowledge the first two address bytes), software would respond by setting the STOP and FLUSH bits and clearing the TXI bit. The I²C Controller sends the STOP condition on the bus and clears the STOP and NCKI bits. The transaction is complete (ignore the following steps).

19. The I²C Controller shifts in a byte of data from the I²C slave on the SDA signal. The I²C Controller sends a Not Acknowledge to the I²C slave if the NAK bit is set (last byte), else it sends an Acknowledge.
20. The I²C Controller asserts the Receive interrupt (RDRF bit set in the Status register).
21. Software responds by reading the I²C Data register which clears the RDRF bit. If there is only one more byte to receive, set the NAK bit of the I²C Control register.
22. If there are one or more bytes to transfer, return to [step 19](#).
23. After the last byte is shifted in, a Not Acknowledge interrupt is generated by the I²C Controller.
24. Software responds by setting the STOP bit of the I²C Control register.
25. A STOP condition is sent to the I²C slave and the STOP and NCKI bits are cleared.

I²C Control Register Definitions

I²C Data Register

The I²C Data register (see [Table 70](#) on page 157) holds the data that is to be loaded into the I²C Shift register during a write to a slave. This register also holds data that is loaded from the I²C Shift register during a read from a slave. The I²C Shift Register is not accessible in the Register File address space, but is used only to buffer incoming and outgoing data.

Table 70. I²C Data Register (I2CDATA)

BITS	7	6	5	4	3	2	1	0
FIELD	DATA							
RESET	0							
R/W	R/W							
ADDR	F50H							

I²C Status Register

The Read-only I²C Status register (Table 71) indicates the status of the I²C Controller.

Table 71. I²C Status Register (I2CSTAT)

BITS	7	6	5	4	3	2	1	0
FIELD	TDRE	RDRF	ACK	10B	RD	TAS	DSS	NCKI
RESET	1	0						
R/W	R							
ADDR	F51H							

TDRE—Transmit Data Register Empty

When the I²C Controller is enabled, this bit is 1 when the I²C Data register is empty. When this bit is set, an interrupt is generated if the TXI bit is set, except when the I²C Controller is shifting in data during the reception of a byte or when shifting an address and the RD bit is set. This bit is cleared by writing to the I2CDATA register.

RDRF—Receive Data Register Full

This bit is set = 1 when the I²C Controller is enabled and the I²C Controller has received a byte of data. When asserted, this bit causes the I²C Controller to generate an interrupt. This bit is cleared by reading the I²C Data register (unless the read is performed using execution of the On-Chip Debugger's Read Register command).

ACK—Acknowledge

This bit indicates the status of the Acknowledge for the last byte transmitted or received. When set, this bit indicates that an Acknowledge occurred for the last byte transmitted or received. This bit is cleared when IEN = 0 or when a Not Acknowledge occurred for the last byte transmitted or received. It is not reset at the beginning of each transaction and is not reset when this register is read.



Caution: *Software must be cautious in making decisions based on this bit within a transaction because software cannot tell when the bit is updated by hardware. In the case of write transactions, the I²C pauses at the beginning of the Acknowledge cycle if the next transmit data or address byte has not been written (TDRE = 1) and STOP and START = 0. In this case the ACK bit is not updated until the transmit interrupt is serviced and the Acknowledge cycle for the previous byte completes. For examples of how the ACK bit can be used, see [Address Only Transaction with a 7-bit Address](#) on page 148 and [Address Only Transaction with a 10-bit Address](#) on page 150.*

10B—10-Bit Address

This bit indicates whether a 10- or 7-bit address is being transmitted. After the START bit is set, if the five most-significant bits of the address are 11110B, this bit is set. When set, it is reset once the first byte of the address has been sent.

RD—Read

This bit indicates the direction of transfer of the data. It is active high during a read. The status of this bit is determined by the least-significant bit of the I²C Shift register after the START bit is set.

TAS—Transmit Address State

This bit is active high while the address is being shifted out of the I²C Shift register.

DSS—Data Shift State

This bit is active high while data is being shifted to or from the I²C Shift register.

NCKI—NACK Interrupt

This bit is set high when a Not Acknowledge condition is received or sent and neither the START nor the STOP bit is active. When set, this bit generates an interrupt that can only be cleared by setting the START or STOP bit, allowing you to specify whether to perform a STOP or a repeated START.

I²C Control Register

The I²C Control register ([Table 72](#)) enables the I²C operation.

Table 72. I²C Control Register (I2CCTL)

BITS	7	6	5	4	3	2	1	0
FIELD	IEN	START	STOP	BIRQ	TXI	NAK	FLUSH	FILTEN
RESET	0							
R/W	R/W	R/W1	R/W1	R/W	R/W	R/W1	W1	R/W
ADDR	F52H							

IEN—I²C Enable

1 = The I²C transmitter and receiver are enabled.

0 = The I²C transmitter and receiver are disabled.

START—Send Start Condition

This bit sends the Start condition. Once asserted, it is cleared by the I²C Controller after it sends the START condition or if the IEN bit is deasserted. If this bit is 1, it cannot be cleared to 0 by writing to the register. After this bit is set, the Start condition is sent if there is data in the I²C Data or I²C Shift register. If there is no data in one of these registers, the I²C Controller waits until the Data register is written. If this bit is set while the I²C Controller is shifting out data, it generates a START condition after the byte shifts and the acknowledge phase completes. If the STOP bit is also set, it also waits until the STOP condition is sent before the sending the START condition.

STOP—Send Stop Condition

This bit causes the I²C Controller to issue a Stop condition after the byte in the I²C Shift register has completed transmission or after a byte has been received in a receive operation. Once set, this bit is reset by the I²C Controller after a Stop condition has been sent or by deasserting the IEN bit. If this bit is 1, it cannot be cleared to 0 by writing to the register.

BIRQ—Baud Rate Generator Interrupt Request

This bit allows the I²C Controller to be used as an additional timer when the I²C Controller is disabled. This bit is ignored when the I²C Controller is enabled.

1 = An interrupt occurs every time the baud rate generator counts down to one.

0 = No baud rate generator interrupt occurs.

TXI—Enable TDRE interrupts

This bit enables the transmit interrupt when the I²C Data register is empty (TDRE = 1).

1 = Transmit interrupt (and DMA transmit request) is enabled.

0 = Transmit interrupt (and DMA transmit request) is disabled.

NAK—Send NAK

This bit sends a Not Acknowledge condition after the next byte of data has been read from the I²C slave. Once asserted, it is deasserted after a Not Acknowledge is sent or the IEN bit is deasserted. If this bit is 1, it cannot be cleared to 0 by writing to the register.

FLUSH—Flush Data

Setting this bit to 1 clears the I²C Data register and sets the TDRE bit to 1. This bit allows flushing of the I²C Data register when a Not Acknowledge interrupt is received after the data has been sent to the I²C Data register. Reading this bit always returns 0.

FILTEN—I²C Signal Filter Enable

This bit enables low-pass digital filters on the SDA and SCL input signals. These filters reject any input pulse with periods less than a full system clock cycle. The filters introduce a 3-system clock cycle latency on the inputs.

1 = low-pass filters are enabled.

0 = low-pass filters are disabled.

I²C Baud Rate High and Low Byte Registers

The I²C Baud Rate High and Low Byte registers (Tables 73 and 73) combine to form a 16-bit reload value, BRG[15:0], for the I²C Baud Rate Generator.

When the I²C is disabled, the Baud Rate Generator can function as a basic 16-bit timer with interrupt on time-out. To configure the Baud Rate Generator as a timer with interrupt on time-out, complete the following procedure:

1. Disable the I²C by clearing the IEN bit in the I²C Control register to 0.
2. Load the desired 16-bit count value into the I²C Baud Rate High and Low Byte registers.
3. Enable the Baud Rate Generator timer function and associated interrupt by setting the BIRQ bit in the I²C Control register to 1.

When configured as a general purpose timer, the interrupt interval is calculated using the following equation:

$$\text{Interrupt Interval (s)} = \text{System Clock Period (s)} \times \text{BRG}[15:0]$$

Table 73. I²C Baud Rate High Byte Register (I2CBRH)

BITS	7	6	5	4	3	2	1	0
FIELD	BRH							
RESET	FFH							
R/W	R/W							
ADDR	F53H							

BRH = I²C Baud Rate High Byte

Most significant byte, BRG[15:8], of the I²C Baud Rate Generator's reload value.

- **Note:** *If the DIAG bit in the I²C Diagnostic Control Register is set to 1, a read of the I2CBRH register returns the current value of the I²C Baud Rate Counter[15:8].*

Table 74. I²C Baud Rate Low Byte Register (I2CBRL)

BITS	7	6	5	4	3	2	1	0
FIELD	BRL							
RESET	FFH							
R/W	R/W							
ADDR	F54H							

BRL = I²C Baud Rate Low Byte
Least significant byte, BRG[7:0], of the I²C Baud Rate Generator's reload value.

- **Note:** *If the DIAG bit in the I²C Diagnostic Control Register is set to 1, a read of the I2CBRL register returns the current value of the I²C Baud Rate Counter[7:0].*

I²C Diagnostic State Register

The I²C Diagnostic State register (Table 75) provides observability of internal state. This is a read only register used for I²C diagnostics and manufacturing test.

Table 75. I²C Diagnostic State Register (I2CDST)

BITS	7	6	5	4	3	2	1	0
FIELD	SCLIN	SDAIN	STPCNT	TXRXSTATE				
RESET	X		0					
R/W	R							
ADDR	F55H							

SCLIN—Value of Serial Clock input signal

SDAIN—Value of the Serial Data input signal

STPCNT—Value of the internal Stop Count control signal

TXRXSTATE—Value of the internal I²C state machine

TXRXSTATE	State Description
0_0000	Idle State
0_0001	START State
0_0010	Send/Receive data bit 7
0_0011	Send/Receive data bit 6
0_0100	Send/Receive data bit 5
0_0101	Send/Receive data bit 4
0_0110	Send/Receive data bit 3
0_0111	Send/Receive data bit 2
0_1000	Send/Receive data bit 1
0_1001	Send/Receive data bit 0
0_1010	Data Acknowledge State
0_1011	Second half of data Acknowledge State used only for not acknowledge
0_1100	First part of STOP state
0_1101	Second part of STOP state
0_1110	10-bit addressing: Acknowledge State for 2nd address byte 7-bit addressing: Address Acknowledge State
0_1111	10-bit address: Bit 0 (Least significant bit) of 2nd address byte 7-bit address: Bit 0 (Least significant bit) (R/W) of address byte
1_0000	10-bit addressing: Bit 7 (Most significant bit) of 1st address byte
1_0001	10-bit addressing: Bit 6 of 1st address byte
1_0010	10-bit addressing: Bit 5 of 1st address byte
1_0011	10-bit addressing: Bit 4 of 1st address byte
1_0100	10-bit addressing: Bit 3 of 1st address byte
1_0101	10-bit addressing: Bit 2 of 1st address byte
1_0110	10-bit addressing: Bit 1 of 1st address byte
1_0111	10-bit addressing: Bit 0 (R/W) of 1st address byte
1_1000	10-bit addressing: Acknowledge state for 1st address byte
1_1001	10-bit addressing: Bit 7 of 2nd address byte 7-bit addressing: Bit 7 of address byte
1_1010	10-bit addressing: Bit 6 of 2nd address byte 7-bit addressing: Bit 6 of address byte
1_1011	10-bit addressing: Bit 5 of 2nd address byte 7-bit addressing: Bit 5 of address byte
1_1100	10-bit addressing: Bit 4 of 2nd address byte 7-bit addressing: Bit 4 of address byte

TXRXSTATE	State Description
1_1101	10-bit addressing: Bit 3 of 2nd address byte 7-bit addressing: Bit 3 of address byte
1_1110	10-bit addressing: Bit 2 of 2nd address byte 7-bit addressing: Bit 2 of address byte
1_1111	10-bit addressing: Bit 1 of 2nd address byte 7-bit addressing: Bit 1 of address byte

I²C Diagnostic Control Register

The I²C Diagnostic register (Table 76) provides control over diagnostic modes. This register is a read/write register used for I²C diagnostics.

Table 76. I²C Diagnostic Control Register (I2CDIAG)

BITS	7	6	5	4	3	2	1	0
FIELD	Reserved							DIAG
RESET	0							
R/W	R							R/W
ADDR	F56H							

DIAG = Diagnostic Control Bit - Selects read back value of the Baud Rate Reload registers.

0 = NORMAL mode. Reading the Baud Rate High and Low Byte registers returns the baud rate reload value.

1 = DIAGNOSTIC mode. Reading the Baud Rate High and Low Byte registers returns the baud rate counter value.



Direct Memory Access Controller

Overview

The 64K Series Direct Memory Access (DMA) Controller provides three independent Direct Memory Access channels. Two of the channels (DMA0 and DMA1) transfer data between the on-chip peripherals and the Register File. The third channel (DMA_ADC) controls the ADC operation and transfers SINGLE-SHOT mode ADC output data to the Register File.

Operation

DMA0 and DMA1 Operation

DMA0 and DMA1, referred to collectively as DMA_x, transfer data either from the on-chip peripheral control registers to the Register File, or from the Register File to the on-chip peripheral control registers. The sequence of operations in a DMA_x data transfer is:

1. DMA_x trigger source requests a DMA data transfer.
2. DMA_x requests control of the system bus (address and data) from the eZ8 CPU.
3. After the eZ8 CPU acknowledges the bus request, DMA_x transfers either a single byte or a two-byte word (depending upon configuration) and then returns system bus control back to the eZ8 CPU.
4. If Current Address equals End Address:
 - DMA_x reloads the original Start Address
 - If configured to generate an interrupt, DMA_x sends an interrupt request to the Interrupt Controller
 - If configured for single-pass operation, DMA_x resets the DEN bit in the DMA_x Control register to 0 and the DMA is disabled.

If Current Address does not equal End Address, the Current Address increments by 1 (single-byte transfer) or 2 (two-byte word transfer).

Configuring DMA0 and DMA1 for Data Transfer

Follow the steps below to configure and enable DMA0 or DMA1:

1. Write to the DMA_x I/O Address register to set the Register File address identifying the on-chip peripheral control register. The upper nibble of the 12-bit address for on-chip peripheral control registers is always F_H. The full address is {F_H, DMA_x_IO[7:0]}.
2. Determine the 12-bit Start and End Register File addresses. The 12-bit Start Address is given by {DMA_x_H[3:0], DMA_START[7:0]}. The 12-bit End Address is given by {DMA_x_H[7:4], DMA_END[7:0]}.
3. Write the Start and End Register File address high nibbles to the DMA_x End/Start Address High Nibble register.
4. Write the lower byte of the Start Address to the DMA_x Start/Current Address register.
5. Write the lower byte of the End Address to the DMA_x End Address register.
6. Write to the DMA_x Control register to complete the following:
 - Select loop or single-pass mode operation
 - Select the data transfer direction (either from the Register File RAM to the on-chip peripheral control register; or from the on-chip peripheral control register to the Register File RAM)
 - Enable the DMA_x interrupt request, if desired
 - Select Word or Byte mode
 - Select the DMA_x request trigger
 - Enable the DMA_x channel

DMA_ADC Operation

DMA_ADC transfers data from the ADC to the Register File. The sequence of operations in a DMA_ADC data transfer is:

1. ADC completes conversion on the current ADC input channel and signals the DMA controller that two-bytes of ADC data are ready for transfer.
2. DMA_ADC requests control of the system bus (address and data) from the eZ8 CPU.
3. After the eZ8 CPU acknowledges the bus request, DMA_ADC transfers the two-byte ADC output value to the Register File and then returns system bus control back to the eZ8 CPU.
4. If the current ADC Analog Input is the highest numbered input to be converted:
 - DMA_ADC resets the ADC Analog Input number to 0 and initiates data conversion on ADC Analog Input 0.
 - If configured to generate an interrupt, DMA_ADC sends an interrupt request to the Interrupt Controller

If the current ADC Analog Input is not the highest numbered input to be converted, DMA_ADC initiates data conversion in the next higher numbered ADC Analog Input.

Configuring DMA_ADC for Data Transfer

Follow the steps below to configure and enable DMA_ADC:

1. Write the DMA_ADC Address register with the 7 most-significant bits of the Register File address for data transfers.
2. Write to the DMA_ADC Control register to complete the following:
 - Enable the DMA_ADC interrupt request, if desired
 - Select the number of ADC Analog Inputs to convert
 - Enable the DMA_ADC channel



Caution: *When using the DMA_ADC to perform conversions on multiple ADC inputs, the Analog-to-Digital Converter must be configured for SINGLE-SHOT mode. If the ADC_IN field in the DMA_ADC Control Register is greater than 000b, the ADC must be in SINGLE-SHOT mode.*

CONTINUOUS mode operation of the ADC can only be used in conjunction with DMA_ADC if the ADC_IN field in the DMA_ADC Control Register is reset to 000b to enable conversion on ADC Analog Input 0 only.

DMA Control Register Definitions

DMAx Control Register

The DMAx Control register (see [Table 77](#) on page 167) enables and selects the mode of operation for DMAx.

Table 77. DMAx Control Register (DMAxCTL)

BITS	7	6	5	4	3	2	1	0
FIELD	DEN	DLE	DDIR	IRQEN	WSEL	RSS		
RESET	0							
R/W	R/W							
ADDR	FB0H, FB8H							

DEN—DMAx Enable

0 = DMAx is disabled and data transfer requests are disregarded.

1 = DMA_x is enabled and initiates a data transfer upon receipt of a request from the trigger source.

DLE—DMA_x Loop Enable

0 = DMA_x reloads the original Start Address and is then disabled after the End Address data is transferred.

1 = DMA_x, after the End Address data is transferred, reloads the original Start Address and continues operating.

DDIR—DMA_x Data Transfer Direction

0 = Register File → on-chip peripheral control register.

1 = on-chip peripheral control register → Register File.

IRQEN—DMA_x Interrupt Enable

0 = DMA_x does not generate any interrupts.

1 = DMA_x generates an interrupt when the End Address data is transferred.

WSEL—Word Select

0 = DMA_x transfers a single byte per request.

1 = DMA_x transfers a two-byte word per request. The address for the on-chip peripheral control register must be an even address.

RSS—Request Trigger Source Select

The Request Trigger Source Select field determines the peripheral that can initiate a DMA transfer. The corresponding interrupts do not need to be enabled within the Interrupt Controller to initiate a DMA transfer. However, if the Request Trigger Source can enable or disable the interrupt request sent to the Interrupt Controller, the interrupt request must be enabled within the Request Trigger Source block.

000 = Timer 0.

001 = Timer 1.

010 = Timer 2.

011 = Timer 3.

100 = DMA0 Control register: UART0 Received Data register contains valid data.

DMA1 Control register: UART0 Transmit Data register empty.

101 = DMA0 Control register: UART1 Received Data register contains valid data. DMA1 Control register: UART1 Transmit Data register empty.

110 = DMA0 Control register: I²C Receiver Interrupt. DMA1 Control register: I²C Transmitter Interrupt register empty.

111 = Reserved.

DMA_x I/O Address Register

The DMA_x I/O Address register (Table 78) contains the low byte of the on-chip peripheral address for data transfer. The full 12-bit Register File address is given by {FH,



DMA_x_IO[7:0]}. When the DMA is configured for two-byte word transfers, the DMA_x I/O Address register must contain an even numbered address.

Table 78. DMA_x I/O Address Register (DMA_xIO)

BITS	7	6	5	4	3	2	1	0
FIELD	DMA_IO							
RESET	X							
R/W	R/W							
ADDR	FB1H, FB9H							

DMA_IO—DMA on-chip peripheral control register address
This byte sets the low byte of the on-chip peripheral control register address on Register File Page FH (addresses F00H to FFFH).

DMA_x Address High Nibble Register

The DMA_x Address High register (Table 79) specifies the upper four bits of address for the Start/Current and End Addresses of DMA_x.

Table 79. DMA_x Address High Nibble Register (DMA_xH)

BITS	7	6	5	4	3	2	1	0
FIELD	DMA_END_H				DMA_START_H			
RESET	X							
R/W	R/W							
ADDR	FB2H, FBAH							

DMA_END_H—DMA_x End Address High Nibble
These bits, used with the DMA_x End Address Low register, form a 12-bit End Address. The full 12-bit address is given by {DMA_END_H[3:0], DMA_END[7:0]}.

DMA_START_H—DMA_x Start/Current Address High Nibble
These bits, used with the DMA_x Start/Current Address Low register, form a 12-bit Start/Current Address. The full 12-bit address is given by {DMA_START_H[3:0], DMA_START[7:0]}.



DMAx Start/Current Address Low Byte Register

The DMAx Start/Current Address Low register, in conjunction with the DMAx Address High Nibble register, forms a 12-bit Start/Current Address. Writes to this register set the Start Address for DMA operations. Each time the DMA completes a data transfer, the 12-bit Start/Current Address increments by either 1 (single-byte transfer) or 2 (two-byte word transfer). Reads from this register return the low byte of the Current Address to be used for the next DMA data transfer.

Table 80. DMAx Start/Current Address Low Byte Register (DMAxSTART)

BITS	7	6	5	4	3	2	1	0
FIELD	DMA_START							
RESET	X							
R/W	R/W							
ADDR	FB3H, FBBH							

DMA_START—DMAx Start/Current Address Low

These bits, with the four lower bits of the DMAx_H register, form the 12-bit Start/Current address. The full 12-bit address is given by {DMA_START_H[3:0], DMA_START[7:0]}.

DMAx End Address Low Byte Register

The DMAx End Address Low Byte register ([Table 80](#)), in conjunction with the DMAx_H register ([Table 81](#)), forms a 12-bit End Address.

Table 81. DMAx End Address Low Byte Register (DMAxEND)

BITS	7	6	5	4	3	2	1	0
FIELD	DMA_END							
RESET	X							
R/W	R/W							
ADDR	FB4H, FBCH							

DMA_END—DMAx End Address Low

These bits, with the four upper bits of the DMAx_H register, form a 12-bit address. This address is the ending location of the DMAx transfer. The full 12-bit address is given by {DMA_END_H[3:0], DMA_END[7:0]}.

DMA_ADC Address Register

The DMA_ADC Address register (Table 83) points to a block of the Register File to store ADC conversion values as displayed in Table 82. This register contains the seven most-significant bits of the 12-bit Register File addresses. The five least-significant bits are calculated from the ADC Analog Input number (5-bit base address is equal to twice the ADC Analog Input number). The 10-bit ADC conversion data is stored as two bytes with the most significant byte of the ADC data stored at the even numbered Register File address.

Table 82 provides an example of the Register File addresses if the DMA_ADC Address register contains the value 72H.

Table 82. DMA_ADC Register File Address Example

ADC Analog Input	Register File Address (Hex) ¹
0	720H-721H
1	722H-723H
2	724H-725H
3	726H-727H
4	728H-729H
5	72AH-72BH
6	72CH-72DH
7	72EH-72FH
8	730H-731H
9	732H-733H
10	734H-735H
11	736H-737H

¹DMAA_ADDR set to 72H.

Table 83. DMA_ADC Address Register (DMAA_ADDR)

BITS	7	6	5	4	3	2	1	0
FIELD	DMAA_ADDR							Reserved
RESET	X							
R/W	R/W							
ADDR	FBDH							

DMAA_ADDR—DMA_ADC Address

These bits specify the seven most-significant bits of the 12-bit Register File addresses used for storing the ADC output data. The ADC Analog Input Number defines the five least-significant bits of the Register File address. Full 12-bit address is {DMAA_ADDR[7:1], 4-bit ADC Analog Input Number, 0}.

Reserved

This bit is reserved and must be 0.

DMA_ADC Control Register

The DMA_ADC Control register (Table 84 on page 172) enables and sets options (DMA enable and interrupt enable) for ADC operation.

Table 84. DMA_ADC Control Register (DMAACTL)

BITS	7	6	5	4	3	2	1	0
FIELD	DAEN	IRQEN	Reserved		ADC_IN			
RESET	0							
R/W	R/W							
ADDR	FBEH							

DAEN—DMA_ADC Enable

0 = DMA_ADC is disabled and the ADC Analog Input Number (ADC_IN) is reset to 0.

1 = DMA_ADC is enabled.

IRQEN—Interrupt Enable

0 = DMA_ADC does not generate any interrupts.

1 = DMA_ADC generates an interrupt after transferring data from the last ADC Analog Input specified by the ADC_IN field.

Reserved

These bits are reserved and must be 0.

ADC_IN—ADC Analog Input Number

These bits set the number of ADC Analog Inputs to be used in the continuous update (data conversion followed by DMA data transfer). The conversion always begins with ADC Analog Input 0 and then progresses sequentially through the other selected ADC Analog Inputs.

0000 = ADC Analog Input 0 updated.

0001 = ADC Analog Inputs 0-1 updated.

0010 = ADC Analog Inputs 0-2 updated.

0011 = ADC Analog Inputs 0-3 updated.

0100 = ADC Analog Inputs 0-4 updated.



0101 = ADC Analog Inputs 0-5 updated.
 0110 = ADC Analog Inputs 0-6 updated.
 0111 = ADC Analog Inputs 0-7 updated.
 1000 = ADC Analog Inputs 0-8 updated.
 1001 = ADC Analog Inputs 0-9 updated.
 1010 = ADC Analog Inputs 0-10 updated.
 1011 = ADC Analog Inputs 0-11 updated.
 1100-1111 = Reserved.

DMA Status Register

The DMA Status register (Table 85 on page 173) indicates the DMA channel that generated the interrupt and the ADC Analog Input that is currently undergoing conversion. Reads from this register reset the Interrupt Request Indicator bits (IRQA, IRQ1, and IRQ0) to 0. Therefore, software interrupt service routines that read this register must process all three interrupt sources from the DMA.

Table 85. DMA_ADC Status Register (DMAA_STAT)

BITS	7	6	5	4	3	2	1	0
FIELD	CADC[3:0]				Reserved	IRQA	IRQ1	IRQ0
RESET	0							
R/W	R							
ADDR	FBFH							

CADC[3:0]—Current ADC Analog Input

This field identifies the Analog Input that the ADC is currently converting.

Reserved

This bit is reserved and must be 0.

IRQA—DMA_ADC Interrupt Request Indicator

This bit is automatically reset to 0 each time a read from this register occurs.

0 = DMA_ADC is not the source of the interrupt from the DMA Controller.

1 = DMA_ADC completed transfer of data from the last ADC Analog Input and generated an interrupt.

IRQ1—DMA1 Interrupt Request Indicator

This bit is automatically reset to 0 each time a read from this register occurs.

0 = DMA1 is not the source of the interrupt from the DMA Controller.

1 = DMA1 completed transfer of data to/from the End Address and generated an interrupt.

IRQ0—DMA0 Interrupt Request Indicator

This bit is automatically reset to 0 each time a read from this register occurs.

0 = DMA0 is not the source of the interrupt from the DMA Controller.

1 = DMA0 completed transfer of data to/from the End Address and generated an interrupt.

Analog-to-Digital Converter

Overview

The Analog-to-Digital Converter (ADC) converts an analog input signal to a 10-bit binary number. The features of the sigma-delta ADC include:

- 12 analog input sources are multiplexed with general-purpose I/O ports
- Interrupt upon conversion complete
- Internal voltage reference generator
- Direct Memory Access (DMA) controller can automatically initiate data conversion and transfer of the data from 1 to 12 of the analog inputs

Architecture

[Figure 34](#) displays the three major functional blocks (converter, analog multiplexer, and voltage reference generator) of the ADC. The ADC converts an analog input signal to its digital representation. The 12-input analog multiplexer selects one of the 12 analog input sources. The ADC requires an input reference voltage for the conversion. The voltage reference for the conversion may be input through the external VREF pin or generated internally by the voltage reference generator.

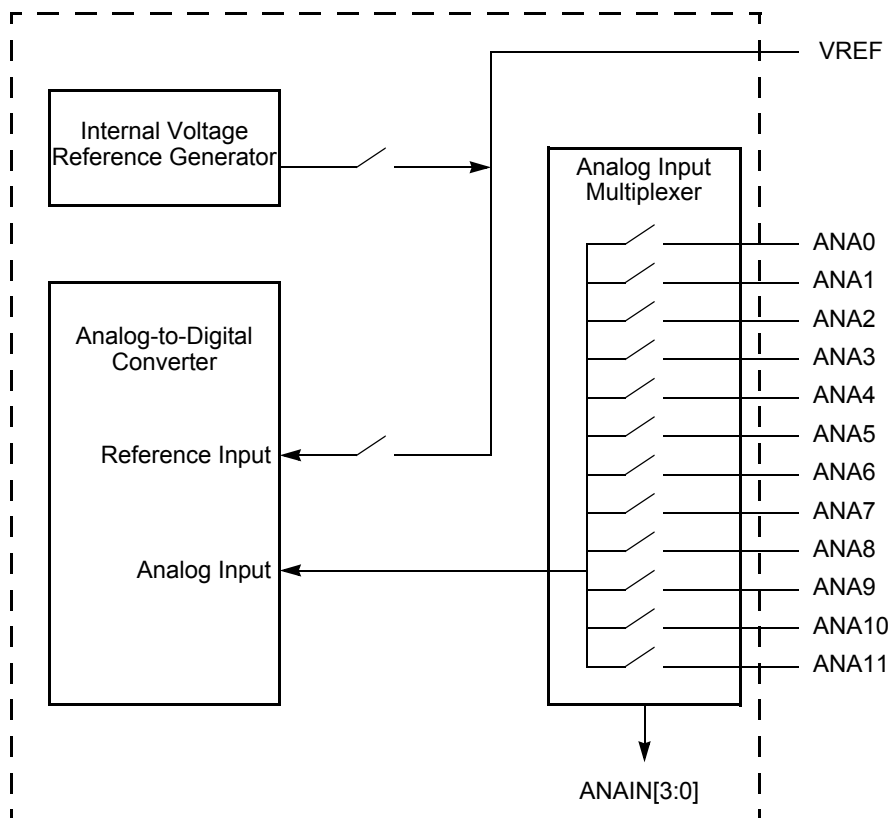

Figure 34. Analog-to-Digital Converter Block Diagram

The sigma-delta ADC architecture provides alias and image attenuation below the amplitude resolution of the ADC in the frequency range of DC to one-half the ADC clock rate (one-fourth the system clock rate). The ADC provides alias free conversion for frequencies up to one-half the ADC clock rate. Thus the sigma-delta ADC exhibits high noise immunity making it ideal for embedded applications. In addition, monotonicity (no missing codes) is guaranteed by design.

Operation

Automatic Power-Down

If the ADC is idle (no conversions in progress) for 160 consecutive system clock cycles, portions of the ADC are automatically powered-down. From this power-down state, the ADC requires 40 system clock cycles to power-up. The ADC powers up when a conversion is requested using the ADC Control register.

Single-Shot Conversion

When configured for single-shot conversion, the ADC performs a single analog-to-digital conversion on the selected analog input channel. After completion of the conversion, the ADC shuts down. Follow the steps below for setting up the ADC and initiating a single-shot conversion:

1. Enable the desired analog inputs by configuring the general-purpose I/O pins for alternate function. This configuration disables the digital input and output drivers.
2. Write to the ADC Control register to configure the ADC and begin the conversion. The bit fields in the ADC Control register can be written simultaneously:
 - Write to the ANAIN[3 : 0] field to select one of the 12 analog input sources.
 - Clear CONT to 0 to select a single-shot conversion.
 - Write to the VREF bit to enable or disable the internal voltage reference generator.
 - Set CEN to 1 to start the conversion.
3. CEN remains 1 while the conversion is in progress. A single-shot conversion requires 5129 system clock cycles to complete. If a single-shot conversion is requested from an ADC powered-down state, the ADC uses 40 additional clock cycles to power-up before beginning the 5129 cycle conversion.
4. When the conversion is complete, the ADC control logic performs the following operations:
 - 10-bit data result written to {ADCD_H[7:0], ADCD_L[7:6]}.
 - CEN resets to 0 to indicate the conversion is complete.
 - An interrupt request is sent to the Interrupt Controller.
5. If the ADC remains idle for 160 consecutive system clock cycles, it is automatically powered-down.

Continuous Conversion

When configured for continuous conversion, the ADC continuously performs an analog-to-digital conversion on the selected analog input. Each new data value over-writes the previous value stored in the ADC Data registers. An interrupt is generated after each conversion.



Caution: *In CONTINUOUS mode, you must be aware that ADC updates are limited by the input signal bandwidth of the ADC and the latency of the ADC and its digital filter. Step changes at the input are not seen at the next output from the ADC. The response of the ADC (in all modes) is limited by the input signal bandwidth and the latency.*

Follow the steps below for setting up the ADC and initiating continuous conversion:

1. Enable the desired analog input by configuring the general-purpose I/O pins for alternate function. This disables the digital input and output driver.
2. Write to the ADC Control register to configure the ADC for continuous conversion. The bit fields in the ADC Control register may be written simultaneously:
 - Write to the ANAIN[3 : 0] field to select one of the 12 analog input sources.
 - Set CONT to 1 to select continuous conversion.
 - Write to the VREF bit to enable or disable the internal voltage reference generator.
 - Set CEN to 1 to start the conversions.
3. When the first conversion in continuous operation is complete (after 5129 system clock cycles, plus the 40 cycles for power-up, if necessary), the ADC control logic performs the following operations:
 - CEN resets to 0 to indicate the first conversion is complete. CEN remains 0 for all subsequent conversions in continuous operation.
 - An interrupt request is sent to the Interrupt Controller to indicate the conversion is complete.
4. Thereafter, the ADC writes a new 10-bit data result to {ADCD_H[7:0], ADCD_L[7:6]} every 256 system clock cycles. An interrupt request is sent to the Interrupt Controller when each conversion is complete.
5. To disable continuous conversion, clear the CONT bit in the ADC Control register to 0.

DMA Control of the ADC

The Direct Memory Access (DMA) Controller can control operation of the ADC including analog input selection and conversion enable. For more information on the DMA and configuring for ADC operations, see [Direct Memory Access Controller](#) on page 165.

ADC Control Register Definitions

ADC Control Register

The ADC Control register selects the analog input channel and initiates the analog-to-digital conversion.

Table 86. ADC Control Register (ADCCTL)

BITS	7	6	5	4	3	2	1	0
FIELD	CEN	Reserved	VREF	CONT	ANAIN[3:0]			
RESET	0		1	0				
R/W	R/W							
ADDR	F70H							

CEN—Conversion Enable

0 = Conversion is complete. Writing a 0 produces no effect. The ADC automatically clears this bit to 0 when a conversion has been completed.

1 = Begin conversion. Writing a 1 to this bit starts a conversion. If a conversion is already in progress, the conversion restarts. This bit remains 1 until the conversion is complete.

Reserved—Must be 0.

$\overline{\text{VREF}}$

0 = Internal voltage reference generator enabled. The VREF pin should be left unconnected (or capacitively coupled to analog ground) if the internal voltage reference is selected as the ADC reference voltage.

1 = Internal voltage reference generator disabled. An external voltage reference must be provided through the VREF pin.

CONT

0 = Single-shot conversion. ADC data is output once at completion of the 5129 system clock cycles.

1 = Continuous conversion. ADC data updated every 256 system clock cycles.

ANAIN—Analog Input Select

These bits select the analog input for conversion. Not all Port pins in this list are available in all packages for the Z8F642x family Z8R642x family of products. For information on the Port pins available with each package style, see [Signal and Pin Descriptions](#) on page 7.

Do not enable unavailable analog inputs.

0000 = ANA0

0001 = ANA1

0010 = ANA2

0011 = ANA3

0100 = ANA4
 0101 = ANA5
 0110 = ANA6
 0111 = ANA7
 1000 = ANA8
 1001 = ANA9
 1010 = ANA10
 1011 = ANA11
 11XX = Reserved.

ADC Data High Byte Register

The ADC Data High Byte register (Table 87) contains the upper eight bits of the 10-bit ADC output. During a single-shot conversion, this value is invalid. Access to the ADC Data High Byte register is read-only. The full 10-bit ADC result is given by {ADCD_H[7:0], ADCD_L[7:6]}. Reading the ADC Data High Byte register latches data in the ADC Low Bits register.

Table 87. ADC Data High Byte Register (ADCD_H)

BITS	7	6	5	4	3	2	1	0
FIELD	ADCD_H							
RESET	X							
R/W	R							
ADDR	F72H							

ADCD_H—ADC Data High Byte

This byte contains the upper eight bits of the 10-bit ADC output. These bits are not valid during a single-shot conversion. During a continuous conversion, the last conversion output is held in this register. These bits are undefined after a Reset.

ADC Data Low Bits Register

The ADC Data Low Bits register (Table 88) contains the lower two bits of the conversion value. The data in the ADC Data Low Bits register is latched each time the ADC Data High Byte register is read. Reading this register always returns the lower two bits of the conversion last read into the ADC High Byte register. Access to the ADC Data Low Bits register is read-only. The full 10-bit ADC result is given by {ADCD_H[7:0], ADCD_L[7:6]}.

Table 88. ADC Data Low Bits Register (ADCD_L)

BITS	7	6	5	4	3	2	1	0
FIELD	ADCD_L		Reserved					
RESET	X							
R/W	R							
ADDR	F73H							

ADCD_L—ADC Data Low Bits

These are the least significant two bits of the 10-bit ADC output. These bits are undefined after a Reset.

Reserved

These bits are reserved and are always undefined.



Flash Memory

Overview

The products in the Z8 Encore! XP 64K Series Flash Microcontrollers feature up to 64 KB (65,536 bytes) of non-volatile Flash memory with read/write/erase capability. The Flash memory can be programmed and erased in-circuit by either user code or through the On-Chip Debugger.

The Flash memory array is arranged in 512-byte per page. The 512-byte page is the minimum Flash block size that can be erased. The Flash memory is also divided into 8 sectors which can be protected from programming and erase operations on a per sector basis.

[Table 89](#) describes the Flash memory configuration for each device in the 64K Series. [Table 90](#) on page 184 lists the sector address ranges. [Figure 35](#) on page 184 displays the Flash memory arrangement.

Table 89. Flash Memory Configurations

Part Number	Flash Size	Number of Pages	Flash Memory Addresses	Sector Size	Number of Sectors	Pages per Sector
Z8F162x	16K (16,384)	32	0000H - 3FFFH	2K (2048)	8	4
Z8F242x	24K (24,576)	48	0000H - 5FFFH	4K (4096)	6	8
Z8F322x	32K (32,768)	64	0000H - 7FFFH	4K (4096)	8	8
Z8F482x	48K (49,152)	96	0000H - BFFFH	8K (8192)	6	16
Z8F642x	64K (65,536)	128	0000H - FFFFH	8K (8192)	8	16

Table 90. Flash Memory Sector Addresses

Sector Number	Flash Sector Address Ranges				
	Z8F162x	Z8F242x	Z8F322x	Z8F482x	Z8F642x
0	0000H-07FFH	0000H-0FFFH	0000H-0FFFH	0000H-1FFFH	0000H-1FFFH
1	0800H-0FFFH	1000H-1FFFH	1000H-1FFFH	2000H-3FFFH	2000H-3FFFH
2	1000H-17FFH	2000H-2FFFH	2000H-2FFFH	4000H-5FFFH	4000H-5FFFH
3	1800H-1FFFH	3000H-3FFFH	3000H-3FFFH	6000H-7FFFH	6000H-7FFFH
4	2000H-27FFH	4000H-4FFFH	4000H-4FFFH	8000H-9FFFH	8000H-9FFFH
5	2800H-2FFFH	5000H-5FFFH	5000H-5FFFH	A000H-BFFFH	A000H-BFFFH
6	3000H-37FFH	N/A	6000H-6FFFH	N/A	C000H-DFFFH
7	3800H-3FFFH	N/A	7000H-7FFFH	N/A	E000H-FFFFH

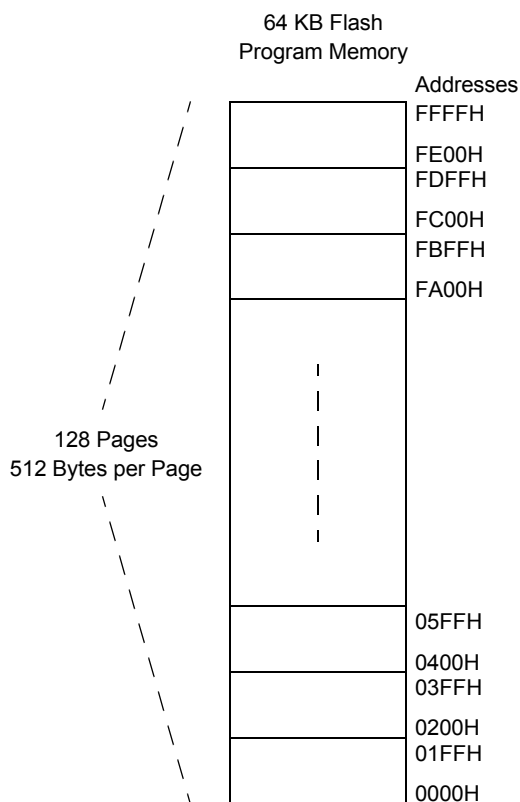

Figure 35. Flash Memory Arrangement

Information Area

Table 91 describes the 64K Series Information Area. This 512-byte Information Area is accessed by setting bit 7 of the Page Select Register to 1. When access is enabled, the Information Area is mapped into Flash Memory and overlays the 512 bytes at addresses FE00H to FFFFH. When the Information Area access is enabled, LDC instructions return data from the Information Area. CPU instruction fetches always comes from Flash Memory regardless of the Information Area access bit. Access to the Information Area is read-only.

Table 91. Z8 Encore! XP 64K Series Flash Microcontrollers Information Area Map

Flash Memory Address (Hex)	Function
FE00H-FE3FH	Reserved
FE40H-FE53H	Part Number 20-character ASCII alphanumeric code Left justified and filled with zeros
FE54H-FFFFH	Reserved

Operation

The Flash Controller provides the proper signals and timing for Byte Programming, Page Erase, and Mass Erase of the Flash memory. The Flash Controller contains a protection mechanism, via the Flash Control register (FCTL), to prevent accidental programming or erasure. The following subsections provide details on the various operations (Lock, Unlock, Sector Protect, Byte Programming, Page Erase, and Mass Erase).

Timing Using the Flash Frequency Registers

Before performing a program or erase operation on the Flash memory, you must first configure the Flash Frequency High and Low Byte registers. The Flash Frequency registers allow programming and erasure of the Flash with system clock frequencies ranging from 20 kHz through 20 MHz (the valid range is limited to the device operating frequencies).

The Flash Frequency High and Low Byte registers combine to form a 16-bit value, `FFREQ`, to control timing for Flash program and erase operations. The 16-bit Flash Frequency value must contain the system clock frequency in kHz. This value is calculated using the following equation:

$$\text{FFREQ}[15:0] = \frac{\text{System Clock Frequency (Hz)}}{1000}$$



Caution: *Flash programming and erasure are not supported for system clock frequencies below 20 kHz, above 20 MHz, or outside of the device operating frequency range. The Flash Frequency High and Low Byte registers must be loaded with the correct value to insure proper Flash programming and erase operations.*

Flash Read Protection

The user code contained within the Flash memory can be protected from external access. Programming the Flash Read Protect Option Bit prevents reading of user code by the On-Chip Debugger or by using the Flash Controller Bypass mode. For more information, see [Option Bits](#) on page 195 and [On-Chip Debugger](#) on page 199.

Flash Write/Erase Protection

The 64K Series provides several levels of protection against accidental program and erasure of the Flash memory contents. This protection is provided by the Flash Controller unlock mechanism, the Flash Sector Protect register, and the Flash Write Protect option bit.

Flash Controller Unlock Mechanism

At Reset, the Flash Controller locks to prevent accidental program or erasure of the Flash memory. To program or erase the Flash memory, the Flash controller must be unlocked. After unlocking the Flash Controller, the Flash can be programmed or erased. Any value written by user code to the Flash Control register or Page Select Register out of sequence will lock the Flash Controller.

Follow the steps below to unlock the Flash Controller from user code:

1. Write 00H to the Flash Control register to reset the Flash Controller.
2. Write the page to be programmed or erased to the Page Select register.

3. Write the first unlock command 73H to the Flash Control register.
4. Write the second unlock command 8CH to the Flash Control register.
5. Re-write the page written in [step 2](#) to the Page Select register.

Flash Sector Protection

The Flash Sector Protect register can be configured to prevent sectors from being programmed or erased. Once a sector is protected, it cannot be unprotected by user code. The Flash Sector Protect register is cleared after reset and any previously written protection values is lost. User code must write this register in their initialization routine if they want to enable sector protection.

The Flash Sector Protect register shares its Register File address with the Page Select register. The Flash Sector Protect register is accessed by writing the Flash Control register with 5EH. Once the Flash Sector Protect register is selected, it can be accessed at the Page Select Register address. When user code writes the Flash Sector Protect register, bits can only be set to 1. Thus, sectors can be protected, but not unprotected, via register write operations. Writing a value other than 5EH to the Flash Control register de-selects the Flash Sector Protect register and re-enables access to the Page Select register.

Follow the steps below to setup the Flash Sector Protect register from user code:

1. Write 00H to the Flash Control register to reset the Flash Controller.
2. Write 5EH to the Flash Control register to select the Flash Sector Protect register.
3. Read and/or write the Flash Sector Protect register which is now at Register File address FF9H.
4. Write 00H to the Flash Control register to return the Flash Controller to its reset state.

Flash Write Protection Option Bit

The Flash Write Protect option bit can be enabled to block all program and erase operations from user code. For more information, see [Option Bits](#) on page 195.

Byte Programming

When the Flash Controller is unlocked, writes to Flash Memory from user code will program a byte into the Flash if the address is located in the unlocked page. An erased Flash byte contains all ones (FFH). The programming operation can only be used to change bits from one to zero. To change a Flash bit (or multiple bits) from zero to one requires a Page Erase or Mass Erase operation.

Byte Programming can be accomplished using the eZ8 CPU's LDC or LDCI instructions. For a description of the LDC and LDCI instructions, refer to *eZ8[™] CPU Core User Manual (UM0128)*.

While the Flash Controller programs the Flash memory, the eZ8 CPU idles but the system clock and on-chip peripherals continue to operate. Interrupts that occur when a Programming operation is in progress are serviced once the Programming operation is complete. To exit Programming mode and lock the Flash Controller, write 00H to the Flash Control register.

User code cannot program Flash Memory on a page that lies in a protected sector. When user code writes memory locations, only addresses located in the unlocked page are programmed. Memory writes outside of the unlocked page are ignored.



Caution: *Each memory location must not be programmed more than twice before an erase occurs.*

Follow the steps below to program the Flash from user code:

1. Write 00H to the Flash Control register to reset the Flash Controller.
2. Write the page of memory to be programmed to the Page Select register.
3. Write the first unlock command 73H to the Flash Control register.
4. Write the second unlock command 8CH to the Flash Control register.
5. Re-write the page written in step 2 to the Page Select register.
6. Write Flash Memory using LDC or LDCI instructions to program the Flash.
7. Repeat [step 6](#) to program additional memory locations on the same page.
8. Write 00H to the Flash Control register to lock the Flash Controller.

Page Erase

The Flash memory can be erased one page (512 bytes) at a time. Page Erasing the Flash memory sets all bytes in that page to the value FFH. The Page Select register identifies the page to be erased. While the Flash Controller executes the Page Erase operation, the eZ8 CPU idles but the system clock and on-chip peripherals continue to operate. The eZ8 CPU resumes operation after the Page Erase operation completes. Interrupts that occur when the Page Erase operation is in progress are serviced once the Page Erase operation is complete. When the Page Erase operation is complete, the Flash Controller returns to its locked state. Only pages located in unprotected sectors can be erased.

Follow the steps below to perform a Page Erase operation:

1. Write 00H to the Flash Control register to reset the Flash Controller.
2. Write the page to be erased to the Page Select register.
3. Write the first unlock command 73H to the Flash Control register.
4. Write the second unlock command 8CH to the Flash Control register.

5. Re-write the page written in step 2 to the Page Select register.
6. Write the Page Erase command 95H to the Flash Control register.

Mass Erase

The Flash memory cannot be Mass Erased by user code.

Flash Controller Bypass

The Flash Controller can be bypassed and the control signals for the Flash memory brought out to the GPIO pins. Bypassing the Flash Controller allows faster Programming algorithms by controlling the Flash programming signals directly.

Flash Controller Bypass is recommended for gang programming applications and large volume customers who do not require in-circuit programming of the Flash memory.

For more information on bypassing the Flash Controller, refer to *Third-Party Flash Programming Support for Z8 Encore!* available for download at www.zilog.com.

Flash Controller Behavior in Debug Mode

The following changes in behavior of the Flash Controller occur when the Flash Controller is accessed using the On-Chip Debugger:

- The Flash Write Protect option bit is ignored.
- The Flash Sector Protect register is ignored for programming and erase operations.
- Programming operations are not limited to the page selected in the Page Select register.
- Bits in the Flash Sector Protect register can be written to one or zero.
- The second write of the Page Select register to unlock the Flash Controller is not necessary.
- The Page Select register can be written when the Flash Controller is unlocked.
- The Mass Erase command is enabled through the Flash Control register.



Caution: *For security reasons, Flash controller allows only a single page to be opened for write/erase. When writing multiple Flash pages, the Flash controller must go through the unlock sequence again to select another page.*

Flash Control Register Definitions

Flash Control Register

The Flash Control register (Table 92) unlocks the Flash Controller for programming and erase operations, or to select the Flash Sector Protect register.

The Write-only Flash Control Register shares its Register File address with the Read-only Flash Status Register.

Table 92. Flash Control Register (FCTL)

BITS	7	6	5	4	3	2	1	0
FIELD	FCMD							
RESET	0							
R/W	W							
ADDR	FF8H							

FCMD—Flash Command
 73H = First unlock command.
 8CH = Second unlock command.
 95H = Page erase command.
 63H = Mass erase command
 5EH = Flash Sector Protect register select.

* All other commands, or any command out of sequence, lock the Flash Controller.

Flash Status Register

The Flash Status register (Table 93) indicates the current state of the Flash Controller. This register can be read at any time. The Read-only Flash Status Register shares its Register File address with the Write-only Flash Control Register.

Table 93. Flash Status Register (FSTAT)

BITS	7	6	5	4	3	2	1	0
FIELD	Reserved		FSTAT					
RESET	0							
R/W	R							
ADDR	FF8H							

Reserved

These bits are reserved and must be 0.

FSTAT—Flash Controller Status

00_0000 = Flash Controller locked

00_0001 = First unlock command received

00_0010 = Second unlock command received

00_0011 = Flash Controller unlocked

00_0100 = Flash Sector Protect register selected

00_1xxx = Program operation in progress

01_0xxx = Page erase operation in progress

10_0xxx = Mass erase operation in progress

Page Select Register

The Page Select (FPS) register (Table 94) selects one of the 128 available Flash memory pages to be erased or programmed. Each Flash Page contains 512 bytes of Flash memory. During a Page Erase operation, all Flash memory locations with the 7 most significant bits of the address given by the PAGE field are erased to FFH.

The Page Select register shares its Register File address with the Flash Sector Protect Register. The Page Select register cannot be accessed when the Flash Sector Protect register is enabled.

Table 94. Page Select Register (FPS)

BITS	7	6	5	4	3	2	1	0
FIELD	INFO_EN	PAGE						
RESET	0							
R/W	R/W							
ADDR	FF9H							

INFO_EN—Information Area Enable

0 = Information Area is not selected.

1 = Information Area is selected. The Information area is mapped into the Flash Memory address space at addresses FE00H through FFFFH.

PAGE—Page Select

This 7-bit field selects the Flash memory page for Programming and Page Erase operations. Flash Memory Address[15:9] = PAGE[6:0].

Flash Sector Protect Register

The Flash Sector Protect register (Table 95) protects Flash memory sectors from being programmed or erased from user code. The Flash Sector Protect register shares its Register File address with the Page Select register. The Flash Sector protect register can be accessed only after writing the Flash Control register with 5EH.

User code can only write bits in this register to 1 (bits cannot be cleared to 0 by user code).

Table 95. Flash Sector Protect Register (FPROT)

BITS	7	6	5	4	3	2	1	0
FIELD	SECT7	SECT6	SECT5	SECT4	SECT3	SECT2	SECT1	SECT0
RESET	0							
R/W	R/W1							
ADDR	FF9H							
Note: R/W1 = Register is accessible for Read operations. Register can be written to 1 only (via user code).								

SECT n —Sector Protect

0 = Sector n can be programmed or erased from user code.

1 = Sector n is protected and cannot be programmed or erased from user code.

* User code can only write bits from 0 to 1.

Flash Frequency High and Low Byte Registers

The Flash Frequency High and Low Byte registers (Table 96 and Table 97) combine to form a 16-bit value, FFREQ, to control timing for Flash program and erase operations. The 16-bit Flash Frequency registers must be written with the system clock frequency in kHz for Program and Erase operations. Calculate the Flash Frequency value using the following equation:

$$\text{FFREQ}[15:0] = \{\text{FFREQH}[7:0], \text{FFREQL}[7:0]\} = \frac{\text{System Clock Frequency}}{1000}$$



Caution: Flash programming and erasure is not supported for system clock frequencies below 20 kHz, above 20 MHz, or outside of the valid operating frequency range for the device. The Flash Frequency High and Low Byte registers must be loaded with the correct value to insure proper program and erase times.

Table 96. Flash Frequency High Byte Register (FFREQH)

BITS	7	6	5	4	3	2	1	0
FIELD	FFREQH							
RESET	0							
R/W	R/W							
ADDR	FFAH							

Table 97. Flash Frequency Low Byte Register (FFREQL)

BITS	7	6	5	4	3	2	1	0
FIELD	FFREQL							
RESET	0							
R/W	R/W							
ADDR	FFBH							

FFREQH and FFREQL—Flash Frequency High and Low Bytes
These 2 bytes, {FFREQH[7:0], FFREQL[7:0]}, contain the 16-bit Flash Frequency value.



Option Bits

Overview

Option Bits allow user configuration of certain aspects of the 64K Series operation. The feature configuration data is stored in the Flash Memory and read during Reset. The features available for control via the Option Bits are:

- Watchdog Timer time-out response selection—interrupt or Reset.
- Watchdog Timer enabled at Reset.
- The ability to prevent unwanted read access to user code in Flash Memory.
- The ability to prevent accidental programming and erasure of the user code in Flash Memory.
- Voltage Brownout configuration—always enabled or disabled during STOP mode to reduce STOP mode power consumption.
- Oscillator mode selection—for high, medium, and low power crystal oscillators, or external RC oscillator.

Operation

Option Bit Configuration By Reset

Each time the Option Bits are programmed or erased, the device must be Reset for the change to take place. During any reset operation (System Reset, Reset, or Stop Mode Recovery), the Option Bits are automatically read from the Flash Memory and written to Option Configuration registers. The Option Configuration registers control operation of the devices within the 64K Series. Option Bit control is established before the device exits Reset and the eZ8 CPU begins code execution. The Option Configuration registers are not part of the Register File and are not accessible for read or write access.

Option Bit Address Space

The first two bytes of Flash Memory at addresses 0000H (see [Table 98](#) on page 196) and 0001H (see [Table 99](#) on page 197) are reserved for the user Option Bits. The byte at Flash Memory address 0000H configures user options. The byte at Flash Memory address 0001H is reserved for future use and must remain unprogrammed.



Flash Memory Address 0000H

Table 98. Flash Option Bits At Flash Memory Address 0000H

BITS	7	6	5	4	3	2	1	0
FIELD	WDT_RE S	WDT_AO	OSC_SEL[1:0]		VBO_AO	RP	Reserved	FWP
RESET	U							
R/W	R/W							
ADDR	Program Memory 0000H							
Note: U = Unchanged by Reset. R/W = Read/Write.								

WDT_RES—Watchdog Timer Reset

0 = Watchdog Timer time-out generates an interrupt request. Interrupts must be globally enabled for the eZ8 CPU to acknowledge the interrupt request.

1 = Watchdog Timer time-out causes a Short Reset. This setting is the default for unprogrammed (erased) Flash.

WDT_AO—Watchdog Timer Always On

0 = Watchdog Timer is automatically enabled upon application of system power. Watchdog Timer can not be disabled except during STOP Mode (if configured to power down during STOP Mode).

1 = Watchdog Timer is enabled upon execution of the WDT instruction. Once enabled, the Watchdog Timer can only be disabled by a Reset or Stop Mode Recovery. This setting is the default for unprogrammed (erased) Flash.

OSC_SEL[1:0]—Oscillator Mode Selection

00 = On-chip oscillator configured for use with external RC networks (<4 MHz).

01 = Minimum power for use with very low frequency crystals (32 kHz to 1.0 MHz).

10 = Medium power for use with medium frequency crystals or ceramic resonators (0.5 MHz to 10.0 MHz).

11 = Maximum power for use with high frequency crystals (8.0 MHz to 20.0 MHz). This setting is the default for unprogrammed (erased) Flash.

VBO_AO—Voltage Brownout Protection Always On

0 = Voltage Brownout Protection is disabled in STOP mode to reduce total power consumption.

1 = Voltage Brownout Protection is always enabled including during STOP mode. This setting is the default for unprogrammed (erased) Flash.

RP—Read Protect

0 = User program code is inaccessible. Limited control features are available through



the On-Chip Debugger.

1 = User program code is accessible. All On-Chip Debugger commands are enabled. This setting is the default for unprogrammed (erased) Flash.

Reserved

These Option Bits are reserved for future use and must always be 1. This setting is the default for unprogrammed (erased) Flash.

FWP—Flash Write Protect (Flash version only)

FWP	Description
0	Programming, Page Erase, and Mass Erase through User Code is disabled. Mass Erase is available through the On-Chip Debugger.
1	Programming, and Page Erase are enabled for all of Flash Program Memory.

Flash Memory Address 0001H

Table 99. Options Bits at Flash Memory Address 0001H

BITS	7	6	5	4	3	2	1	0
FIELD	Reserved							
RESET	U							
R/W	R/W							
ADDR	Program Memory 0001H							
Note: U = Unchanged by Reset. R = Read-Only. R/W = Read/Write.								

Reserved

These Option Bits are reserved for future use and must always be 1. This setting is the default for unprogrammed (erased) Flash.



On-Chip Debugger

Overview

The 64K Series products contain an integrated On-Chip Debugger (OCD) that provides advanced debugging features including:

- Reading and writing of the Register File
- Reading and writing of Program and Data Memory
- Setting of Breakpoints
- Execution of eZ8 CPU instructions

Architecture

The On-Chip Debugger consists of four primary functional blocks: transmitter, receiver, auto-baud generator, and debug controller. [Figure 36](#) displays the architecture of the On-Chip Debugger.

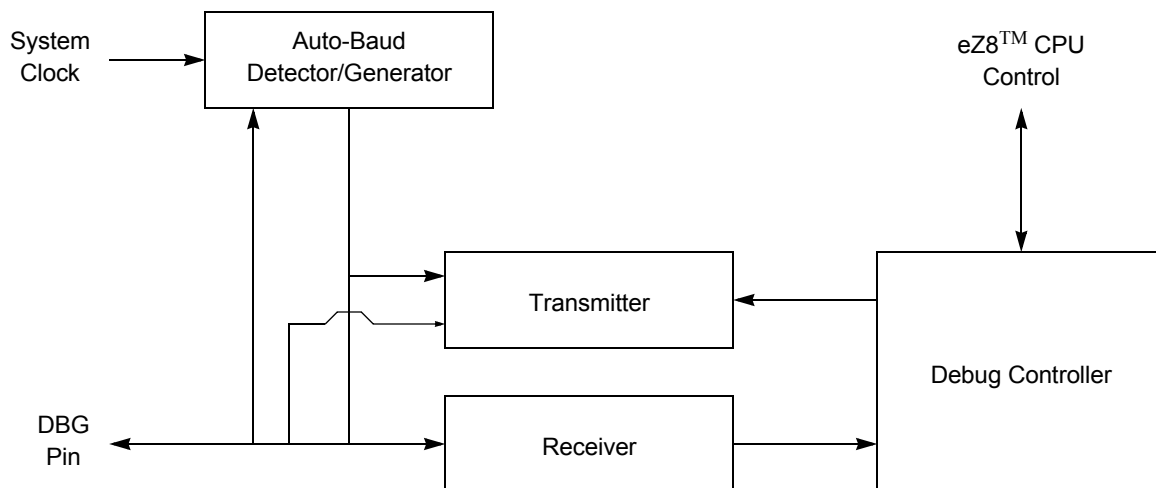

Figure 36. On-Chip Debugger Block Diagram

Operation

OCD Interface

The On-Chip Debugger uses the DBG pin for communication with an external host. This one-pin interface is a bi-directional open-drain interface that transmits and receives data. Data transmission is half-duplex, in that transmit and receive cannot occur simultaneously. The serial data on the DBG pin is sent using the standard asynchronous data format defined in RS-232. This pin can interface the 64K Series products to the serial port of a host PC using minimal external hardware. Two different methods for connecting the DBG pin to an RS-232 interface are depicted in [Figure 37](#) and [Figure 38](#) on page 201.



Caution: For operation of the On-Chip Debugger, **all** power pins (V_{DD} and AV_{DD}) must be supplied with power, and **all** ground pins (V_{SS} and AV_{SS}) must be properly grounded.

The DBG pin is open-drain and must always be connected to V_{DD} through an external pull-up resistor to ensure proper operation.

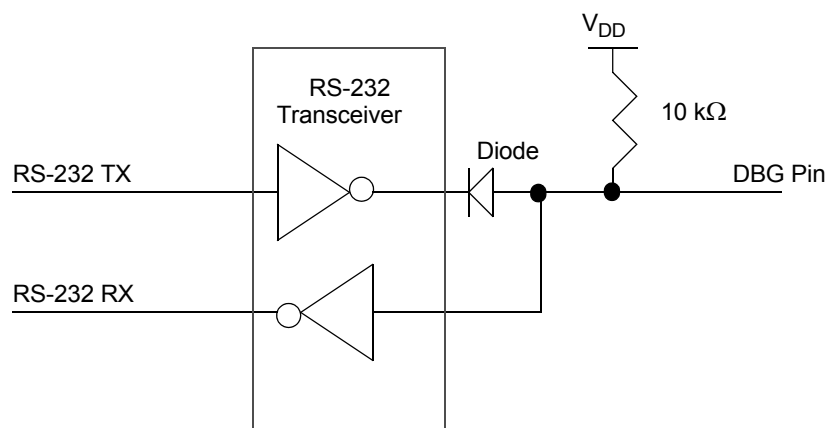

Figure 37. Interfacing the On-Chip Debugger's DBG Pin with an RS-232 Interface (1)

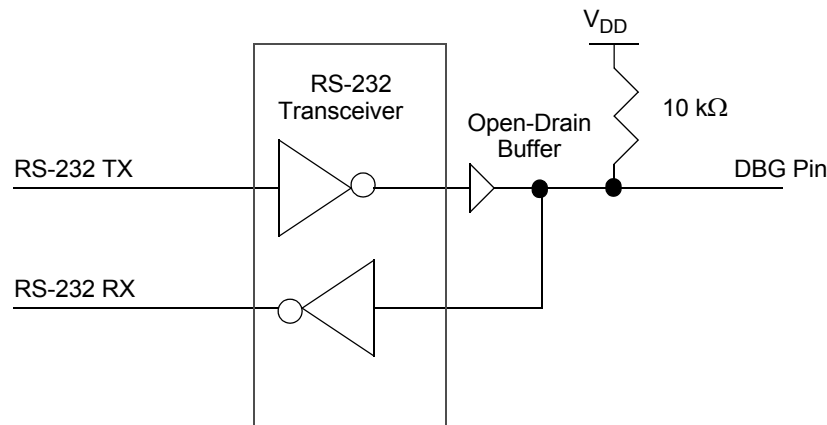

Figure 38. Interfacing the On-Chip Debugger's DBG Pin with an RS-232 Interface (2)

DEBUG Mode

The operating characteristics of the 64K Series devices in DEBUG mode are:

- The eZ8 CPU fetch unit stops, idling the eZ8 CPU, unless directed by the OCD to execute specific instructions.
- The system clock operates unless in STOP mode.
- All enabled on-chip peripherals operate unless in STOP mode.
- Automatically exits HALT mode.
- Constantly refreshes the Watchdog Timer, if enabled.

Entering DEBUG Mode

The device enters DEBUG mode following any of the following operations:

- Writing the DBGMODE bit in the OCD Control Register to 1 using the OCD interface.
- eZ8 CPU execution of a BRK (Breakpoint) instruction (when enabled).
- If the DBG pin is Low when the device exits Reset, the On-Chip Debugger automatically puts the device into DEBUG mode.

Exiting DEBUG Mode

The device exits DEBUG mode following any of the following operations:

- Clearing the DBGMODE bit in the OCD Control Register to 0.
- Power-On Reset
- Voltage Brownout reset

- Asserting the $\overline{\text{RESET}}$ pin Low to initiate a Reset.
- Driving the DBG pin Low while the device is in STOP mode initiates a system reset.

OCD Data Format

The OCD interface uses the asynchronous data format defined for RS-232. Each character is transmitted as 1 Start bit, 8 data bits (least-significant bit first), and 1 Stop bit (see [Figure 39](#)).

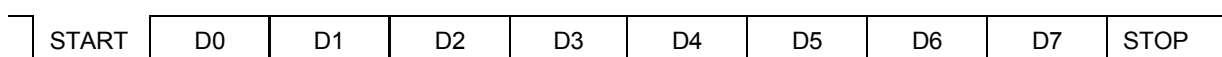

Figure 39. OCD Data Format

OCD Auto-Baud Detector/Generator

To run over a range of baud rates (bits per second) with various system clock frequencies, the On-Chip Debugger has an Auto-Baud Detector/Generator. After a reset, the OCD is idle until it receives data. The OCD requires that the first character sent from the host is the character 80H. The character 80H has eight continuous bits Low (one Start bit plus 7 data bits). The Auto-Baud Detector measures this period and sets the OCD Baud Rate Generator accordingly.

The Auto-Baud Detector/Generator is clocked by the system clock. The minimum baud rate is the system clock frequency divided by 512. For optimal operation, the maximum recommended baud rate is the system clock frequency divided by 8. The theoretical maximum baud rate is the system clock frequency divided by 4. This theoretical maximum is possible for low noise designs with clean signals. [Table 100](#) lists minimum and recommended maximum baud rates for sample crystal frequencies.

Table 100. OCD Baud-Rate Limits

System Clock Frequency (MHz)	Recommended Maximum Baud Rate (kbits/s)	Minimum Baud Rate (kbits/s)
20.0	2500	39.1
1.0	125.0	1.96
0.032768 (32 kHz)	4.096	0.064

If the OCD receives a Serial Break (nine or more continuous bits Low) the Auto-Baud Detector/Generator resets. The Auto-Baud Detector/Generator can then be reconfigured by sending 80H.

OCD Serial Errors

The On-Chip Debugger can detect any of the following error conditions on the DBG pin:

- Serial Break (a minimum of nine continuous bits Low).
- Framing Error (received Stop bit is Low).
- Transmit Collision (OCD and host simultaneous transmission detected by the OCD).

When the OCD detects one of these errors, it aborts any command currently in progress, transmits a Serial Break 4096 system clock cycles long back to the host, and resets the Auto-Baud Detector/Generator. A Framing Error or Transmit Collision may be caused by the host sending a Serial Break to the OCD. Because of the open-drain nature of the interface, returning a Serial Break back to the host only extends the length of the Serial Break if the host releases the Serial Break early.

The host transmits a Serial Break on the DBG pin when first connecting to the 64K Series devices or when recovering from an error. A Serial Break from the host resets the Auto-Baud Generator/Detector but does not reset the OCD Control register. A Serial Break leaves the device in DEBUG mode if that is the current mode. The OCD is held in Reset until the end of the Serial Break when the DBG pin returns High. Because of the open-drain nature of the DBG pin, the host can send a Serial Break to the OCD even if the OCD is transmitting a character.

Breakpoints

Execution Breakpoints are generated using the BRK instruction (opcode 00H). When the eZ8 CPU decodes a BRK instruction, it signals the On-Chip Debugger. If Breakpoints are enabled, the OCD idles the eZ8 CPU and enters DEBUG mode. If Breakpoints are not enabled, the OCD ignores the BRK signal and the BRK instruction operates as an NOP.

If breakpoints are enabled, the OCD can be configured to automatically enter DEBUG mode, or to loop on the break instruction. If the OCD is configured to loop on the BRK instruction, then the CPU is still enabled to service DMA and interrupt requests.

The loop on BRK instruction can be used to service interrupts in the background. For interrupts to be serviced in the background, there cannot be any breakpoints in the interrupt service routine. Otherwise, the CPU stops on the breakpoint in the interrupt routine. For interrupts to be serviced in the background, interrupts must also be enabled. Debugging software should not automatically enable interrupts when using this feature, since interrupts are typically disabled during critical sections of code where interrupts should not occur (such as adjusting the stack pointer or modifying shared data).

Software can poll the IDLE bit of the OCDSTAT register to determine if the OCD is looping on a BRK instruction. When software wants to stop the CPU on the BRK instruction it is looping on, software should not set the DBGMODE bit of the OCDCTL register. The CPU may have vectored to and be in the middle of an interrupt service routine when this bit gets set. Instead, software must clear the BRKLP bit. This action allows the CPU to

finish the interrupt service routine it may be in and return the BRK instruction. When the CPU returns to the BRK instruction it was previously looping on, it automatically sets the DBGMODE bit and enter DEBUG mode.

Software detects that the majority of the OCD commands are still disabled when the eZ8[™] CPU is looping on a BRK instruction. The eZ8 CPU must be stopped and the part must be in DEBUG mode before these commands can be issued.

Breakpoints in Flash Memory

The BRK instruction is opcode 00H, which corresponds to the fully programmed state of a byte in Flash memory. To implement a Breakpoint, write 00H to the desired address, overwriting the current instruction. To remove a Breakpoint, the corresponding page of Flash memory must be erased and reprogrammed with the original data.

On-Chip Debugger Commands

The host communicates to the On-Chip Debugger by sending OCD commands using the DBG interface. During normal operation, only a subset of the OCD commands are available. In DEBUG mode, all OCD commands become available unless the user code and control registers are protected by programming the Read Protect Option Bit (RP). The Read Protect Option Bit prevents the code in memory from being read out of the 64K Series products. When this option is enabled, several of the OCD commands are disabled. [Table 101](#) contains a summary of the On-Chip Debugger commands. Each OCD command is described in detail in the bulleted list following [Table 101](#).

[Table 101](#) indicates those commands that operate when the device is not in DEBUG mode (normal operation) and those commands that are disabled by programming the Read Protect Option Bit.

Table 101. On-Chip Debugger Commands

Debug Command	Command Byte	Enabled when NOT in DEBUG mode?	Disabled by Read Protect Option Bit
Read OCD Revision	00H	Yes	-
Read OCD Status Register	02H	Yes	-
Read Runtime Counter	03H	-	-
Write OCD Control Register	04H	Yes	Cannot clear DBGMODE bit
Read OCD Control Register	05H	Yes	-

Table 101. On-Chip Debugger Commands (Continued)

Debug Command	Command Byte	Enabled when NOT in DEBUG mode?	Disabled by Read Protect Option Bit
Write Program Counter	06H	-	Disabled
Read Program Counter	07H	-	Disabled
Write Register	08H	-	Only writes of the Flash Memory Control registers are allowed. Additionally, only the Mass Erase command is allowed to be written to the Flash Control register.
Read Register	09H	-	Disabled
Write Program Memory	0AH	-	Disabled
Read Program Memory	0BH	-	Disabled
Write Data Memory	0CH	-	Disabled
Read Data Memory	0DH	-	Disabled
Read Program Memory CRC	0EH	-	-
Reserved	0FH	-	-
Step Instruction	10H	-	Disabled
Stuff Instruction	11H	-	Disabled
Execute Instruction	12H	-	Disabled
Reserved	13H - FFH	-	-

In the following list of OCD Commands, data and commands sent from the host to the On-Chip Debugger are identified by 'DBG ← Command/Data'. Data sent from the On-Chip Debugger back to the host is identified by 'DBG → Data'

- Read OCD Revision (00H)**—The Read OCD Revision command determines the version of the On-Chip Debugger. If OCD commands are added, removed, or changed, this revision number changes.

```
DBG ← 00H
DBG → OCDREV[15:8] (Major revision number)
DBG → OCDREV[7:0] (Minor revision number)
```
- Read OCD Status Register (02H)**—The Read OCD Status Register command reads the OCDSTAT register.

```
DBG ← 02H
DBG → OCDSTAT[7:0]
```

- Write OCD Control Register (04H)**—The Write OCD Control Register command writes the data that follows to the OCDCTL register. When the Read Protect Option Bit is enabled, the DBGMODE bit (OCDCTL[7]) can only be set to 1, it cannot be cleared to 0 and the only method of putting the device back into normal operating mode is to reset the device.

```
DBG ← 04H
DBG ← OCDCTL[7:0]
```
- Read OCD Control Register (05H)**—The Read OCD Control Register command reads the value of the OCDCTL register.

```
DBG ← 05H
DBG → OCDCTL[7:0]
```
- Write Program Counter (06H)**—The Write Program Counter command writes the data that follows to the eZ8 CPU's Program Counter (PC). If the device is not in DEBUG mode or if the Read Protect Option Bit is enabled, the Program Counter (PC) values are discarded.

```
DBG ← 06H
DBG ← ProgramCounter[15:8]
DBG ← ProgramCounter[7:0]
```
- Read Program Counter (07H)**—The Read Program Counter command reads the value in the eZ8 CPU's Program Counter (PC). If the device is not in DEBUG mode or if the Read Protect Option Bit is enabled, this command returns FFFFH.

```
DBG ← 07H
DBG → ProgramCounter[15:8]
DBG → ProgramCounter[7:0]
```
- Write Register (08H)**—The Write Register command writes data to the Register File. Data can be written 1-256 bytes at a time (256 bytes can be written by setting size to zero). If the device is not in DEBUG mode, the address and data values are discarded. If the Read Protect Option Bit is enabled, then only writes to the Flash Control Registers are allowed and all other register write data values are discarded.

```
DBG ← 08H
DBG ← {4'h0, Register Address[11:8]}
DBG ← Register Address[7:0]
DBG ← Size[7:0]
DBG ← 1-256 data bytes
```
- Read Register (09H)**—The Read Register command reads data from the Register File. Data can be read 1-256 bytes at a time (256 bytes can be read by setting size to zero). If the device is not in DEBUG mode or if the Read Protect Option Bit is enabled, this command returns FFH for all the data values.

```
DBG ← 09H
DBG ← {4'h0, Register Address[11:8]}
DBG ← Register Address[7:0]
```

DBG ← Size[7:0]
DBG → 1-256 data bytes

- **Write Program Memory (0AH)**—The Write Program Memory command writes data to Program Memory. This command is equivalent to the LDC and LDCI instructions. Data can be written 1-65536 bytes at a time (65536 bytes can be written by setting size to zero). The on-chip Flash Controller must be written to and unlocked for the programming operation to occur. If the Flash Controller is not unlocked, the data is discarded. If the device is not in DEBUG mode or if the Read Protect Option Bit is enabled, the data is discarded.

DBG ← 0AH
DBG ← Program Memory Address[15:8]
DBG ← Program Memory Address[7:0]
DBG ← Size[15:8]
DBG ← Size[7:0]
DBG ← 1-65536 data bytes

- **Read Program Memory (0BH)**—The Read Program Memory command reads data from Program Memory. This command is equivalent to the LDC and LDCI instructions. Data can be read 1-65536 bytes at a time (65536 bytes can be read by setting size to zero). If the device is not in DEBUG mode or if the Read Protect Option Bit is enabled, this command returns FFH for the data.

DBG ← 0BH
DBG ← Program Memory Address[15:8]
DBG ← Program Memory Address[7:0]
DBG ← Size[15:8]
DBG ← Size[7:0]
DBG → 1-65536 data bytes

- **Write Data Memory (0CH)**—The Write Data Memory command writes data to Data Memory. This command is equivalent to the LDE and LDEI instructions. Data can be written 1-65536 bytes at a time (65536 bytes can be written by setting size to zero). If the device is not in DEBUG mode or if the Read Protect Option Bit is enabled, the data is discarded.

DBG ← 0CH
DBG ← Data Memory Address[15:8]
DBG ← Data Memory Address[7:0]
DBG ← Size[15:8]
DBG ← Size[7:0]
DBG ← 1-65536 data bytes

- **Read Data Memory (0DH)**—The Read Data Memory command reads from Data Memory. This command is equivalent to the LDE and LDEI instructions. Data can be read 1-65536 bytes at a time (65536 bytes can be read by setting size to zero). If the device is not in DEBUG mode, this command returns FFH for the data.

DBG ← 0DH
DBG ← Data Memory Address[15:8]

DBG ← Data Memory Address[7:0]
 DBG ← Size[15:8]
 DBG ← Size[7:0]
 DBG → 1-65536 data bytes

- **Read Program Memory CRC (0EH)**—The Read Program Memory CRC command computes and returns the CRC (cyclic redundancy check) of Program Memory using the 16-bit CRC-CCITT polynomial. If the device is not in DEBUG mode, this command returns `FFFFH` for the CRC value. Unlike most other OCD Read commands, there is a delay from issuing of the command until the OCD returns the data. The OCD reads the Program Memory, calculates the CRC value, and returns the result. The delay is a function of the Program Memory size and is approximately equal to the system clock period multiplied by the number of bytes in the Program Memory.

DBG ← 0EH
 DBG → CRC[15:8]
 DBG → CRC[7:0]

- **Step Instruction (10H)**—The Step Instruction command steps one assembly instruction at the current Program Counter (PC) location. If the device is not in DEBUG mode or the Read Protect Option Bit is enabled, the OCD ignores this command.

DBG ← 10H

- **Stuff Instruction (11H)**—The Stuff Instruction command steps one assembly instruction and allows specification of the first byte of the instruction. The remaining 0-4 bytes of the instruction are read from Program Memory. This command is useful for stepping over instructions where the first byte of the instruction has been overwritten by a Breakpoint. If the device is not in DEBUG mode or the Read Protect Option Bit is enabled, the OCD ignores this command.

DBG ← 11H
 DBG ← opcode[7:0]

- **Execute Instruction (12H)**—The Execute Instruction command allows sending an entire instruction to be executed to the eZ8 CPU. This command can also step over Breakpoints. The number of bytes to send for the instruction depends on the opcode. If the device is not in DEBUG mode or the Read Protect Option Bit is enabled, the OCD ignores this command

DBG ← 12H
 DBG ← 1-5 byte opcode

On-Chip Debugger Control Register Definitions

OCD Control Register

The OCD Control register (Table 102) controls the state of the On-Chip Debugger. This register enters or exits DEBUG mode and enables the BRK instruction. It can also reset the Z8F642x family, Z8R642x family device.

A ‘reset and stop’ function can be achieved by writing 81H to this register. A ‘reset and go’ function can be achieved by writing 41H to this register. If the device is in DEBUG mode, a ‘run’ function can be implemented by writing 40H to this register.

Table 102. OCD Control Register (OCDCTL)

BITS	7	6	5	4	3	2	1	0
FIELD	DBGMODE	BRKEN	DBGACK	BRKLOOP			Reserved	RST
RESET	0							
R/W	R/W			R				R/W

DBGMODE—DEBUG Mode

Setting this bit to 1 causes the device to enter DEBUG mode. When in DEBUG mode, the eZ8 CPU stops fetching new instructions. Clearing this bit causes the eZ8 CPU to start running again. This bit is automatically set when a BRK instruction is decoded and Breakpoints are enabled. If the Read Protect Option Bit is enabled, this bit can only be cleared by resetting the device, it cannot be written to 0.

0 = The 64K Series device is operating in NORMAL mode.

1 = The 64K Series device is in DEBUG mode.

BRKEN—Breakpoint Enable

This bit controls the behavior of the BRK instruction (opcode 00H). By default, Breakpoints are disabled and the BRK instruction behaves like a NOP. If this bit is set to 1 and a BRK instruction is decoded, the OCD takes action dependent upon the BRKLOOP bit.

0 = BRK instruction is disabled.

1 = BRK instruction is enabled.

DBGACK—Debug Acknowledge

This bit enables the debug acknowledge feature. If this bit is set to 1, then the OCD sends an Debug Acknowledge character (FFH) to the host when a Breakpoint occurs.

0 = Debug Acknowledge is disabled.

1 = Debug Acknowledge is enabled.

BRKLOOP—Breakpoint Loop

This bit determines what action the OCD takes when a BRK instruction is decoded if breakpoints are enabled (BRKEN is 1). If this bit is 0, then the DBGMODE bit is automatically set to 1 and the OCD entered DEBUG mode. If BRKLOOP is set to 1, then the



eZ8 CPU loops on the BRK instruction.
0 = BRK instruction sets DBGMODE to 1.
1 = eZ8 CPU loops on BRK instruction.

Reserved
These bits are reserved and must be 0.

RST—Reset
Setting this bit to 1 resets the 64K Series devices. The devices go through a normal Power-On Reset sequence with the exception that the On-Chip Debugger is not reset. This bit is automatically cleared to 0 when the reset finishes.
0 = No effect
1 = Reset the 64K Series device

OCD Status Register

The OCD Status register (Table 103) reports status information about the current state of the debugger and the system.

Table 103. OCD Status Register (OCDSTAT)

BITS	7	6	5	4	3	2	1	0
FIELD	IDLE	HALT	RPEN	Reserved				
RESET	0							
R/W	R							

IDLE—CPU idling
This bit is set if the part is in DEBUG mode (DBGMODE is 1), or if a BRK instruction occurred since the last time OCDCTL was written. This can be used to determine if the CPU is running or if it is idling.
0 = The eZ8 CPU is running.
1 = The eZ8 CPU is either stopped or looping on a BRK instruction.

HALT—HALT Mode
0 = The device is not in HALT mode.
1 = The device is in HALT mode.

RPEN—Read Protect Option Bit Enabled
0 = The Read Protect Option Bit is disabled (1).
1 = The Read Protect Option Bit is enabled (0), disabling many OCD commands.

Reserved
These bits are always 0.

On-Chip Oscillator

Overview

The products in the 64K Series feature an on-chip oscillator for use with external crystals with frequencies from 32 kHz to 20 MHz. In addition, the oscillator can support external RC networks with oscillation frequencies up to 4 MHz or ceramic resonators with oscillation frequencies up to 20 MHz. This oscillator generates the primary system clock for the internal eZ8[™] CPU and the majority of the on-chip peripherals. Alternatively, the X_{IN} input pin can also accept a CMOS-level clock input signal (32 kHz–20 MHz). If an external clock generator is used, the X_{OUT} pin must be left unconnected.

When configured for use with crystal oscillators or external clock drivers, the frequency of the signal on the X_{IN} input pin determines the frequency of the system clock (that is, no internal clock divider). In RC operation, the system clock is driven by a clock divider (divide by 2) to ensure 50% duty cycle.

Operating Modes

The 64K Series products support four different oscillator modes:

- On-chip oscillator configured for use with external RC networks (<4 MHz).
- Minimum power for use with very low frequency crystals (32 kHz to 1.0 MHz).
- Medium power for use with medium frequency crystals or ceramic resonators (0.5 MHz to 10.0 MHz).
- Maximum power for use with high frequency crystals or ceramic resonators (8.0 MHz to 20.0 MHz).

The oscillator mode is selected through user-programmable Option Bits. For more information, see [Option Bits](#) on page 195.

Crystal Oscillator Operation

[Figure 40](#) on page 212 displays a recommended configuration for connection with an external fundamental-mode, parallel-resonant crystal operating at 20 MHz. Recommended 20 MHz crystal specifications are provided in [Table 104](#) on page 212. Resistor R1 is optional and limits total power dissipation by the crystal. The printed circuit board layout

must add no more than 4 pF of stray capacitance to either the X_{IN} or X_{OUT} pins. If oscillation does not occur, reduce the values of capacitors C1 and C2 to decrease loading.

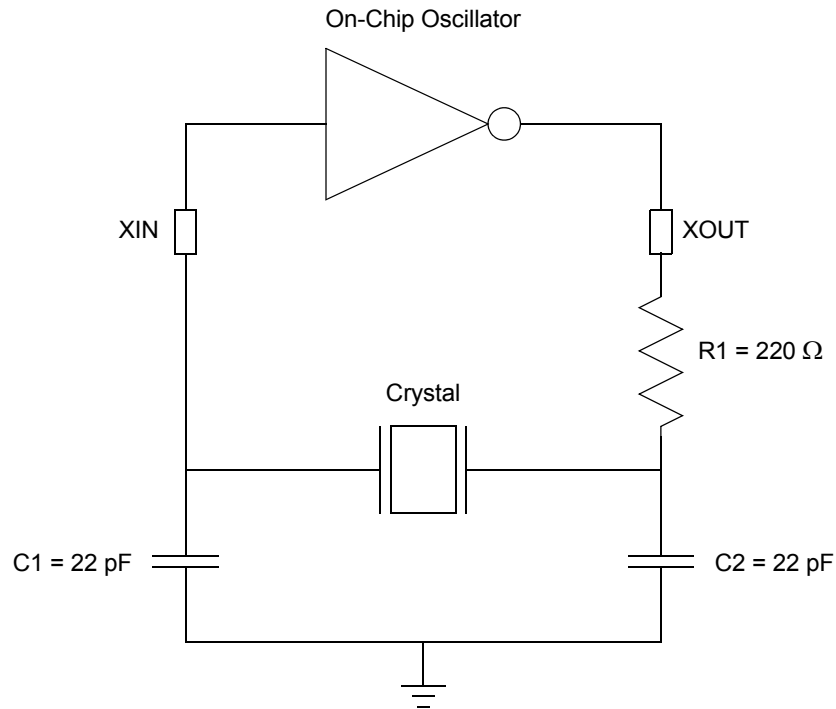

Figure 40. Recommended 20 MHz Crystal Oscillator Configuration

Table 104. Recommended Crystal Oscillator Specifications (20 MHz Operation)

Parameter	Value	Units	Comments
Frequency	20	MHz	
Resonance	Parallel		
Mode	Fundamental		
Series Resistance (R _S)	25	Ω	Maximum
Load Capacitance (C _L)	20	pF	Maximum
Shunt Capacitance (C ₀)	7	pF	Maximum
Drive Level	1	mW	Maximum

Oscillator Operation with an External RC Network

The External RC oscillator mode is applicable to timing insensitive applications. [Figure 41](#) displays a recommended configuration for connection with an external resistor-capacitor (RC) network.

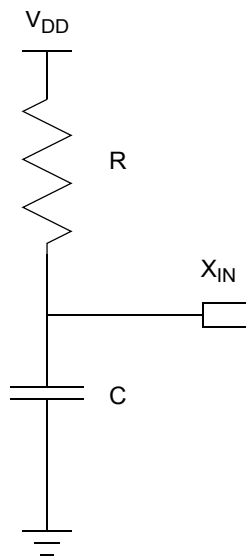

Figure 41. Connecting the On-Chip Oscillator to an External RC Network

An external resistance value of 45 k Ω is recommended for oscillator operation with an external RC network. The minimum resistance value to ensure operation is 40 k Ω . The typical oscillator frequency can be estimated from the values of the resistor (R in k Ω) and capacitor (C in pF) elements using the following equation:

$$\text{Oscillator Frequency (kHz)} = \frac{1 \times 10^6}{(0.4 \times R \times C) + (4 \times C)}$$

[Figure 42](#) displays the typical (3.3 V and 25 $^{\circ}$ C) oscillator frequency as a function of the capacitor (C in pF) employed in the RC network assuming a 45 k Ω external resistor. For very small values of C , the parasitic capacitance of the oscillator XIN pin and the printed circuit board should be included in the estimation of the oscillator frequency.

It is possible to operate the RC oscillator using only the parasitic capacitance of the package and printed circuit board. To minimize sensitivity to external parasitics, external capacitance values in excess of 20 pF are recommended.

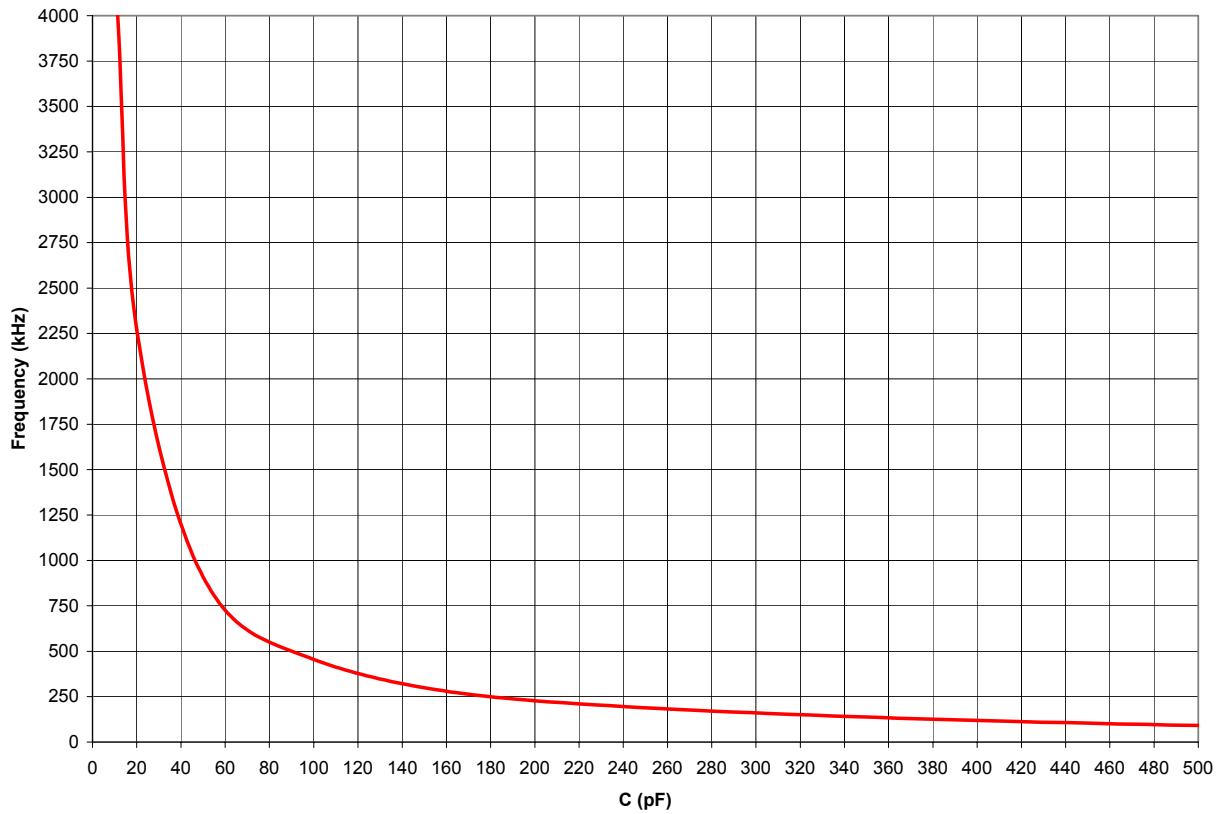

Figure 42. Typical RC Oscillator Frequency as a Function of the External Capacitance with a 45 k Ω Resistor



Caution: *When using the external RC oscillator mode, the oscillator may stop oscillating if the power supply drops below 2.7 V, but before the power supply drops to the voltage brown-out threshold. The oscillator will resume oscillation as soon as the supply voltage exceeds 2.7 V.*

Electrical Characteristics

Absolute Maximum Ratings

Stresses greater than those listed in [Table 105](#) may cause permanent damage to the device. These ratings are stress ratings only. Operation of the device at any condition outside those indicated in the operational sections of these specifications is not implied. Exposure to absolute maximum rating conditions for extended periods may affect device reliability. For improved reliability, unused inputs must be tied to one of the supply voltages (V_{DD} or V_{SS}).

Table 105. Absolute Maximum Ratings

Parameter	Minimum	Maximum	Units	Notes
Ambient temperature under bias	-40	+125	C	
Storage temperature	-65	+150	C	
Voltage on any pin with respect to V_{SS}	-0.3	+5.5	V	1
Voltage on V_{DD} pin with respect to V_{SS}	-0.3	+3.6	V	
Maximum current on input and/or inactive output pin	-5	+5	μ A	
Maximum output current from active output pin	-25	+25	mA	
80-Pin QFP Maximum Ratings at -40 °C to 70 °C				
Total power dissipation		550	mW	
Maximum current into V_{DD} or out of V_{SS}		150	mA	
80-Pin QFP Maximum Ratings at 70 °C to 125 °C				
Total power dissipation		200	mW	
Maximum current into V_{DD} or out of V_{SS}		56	mA	
68-Pin PLCC Maximum Ratings at -40 °C to 70 °C				
Total power dissipation		1000	mW	
Maximum current into V_{DD} or out of V_{SS}		275	mA	
68-Pin PLCC Maximum Ratings at 70 °C to 125 °C				
Total power dissipation		500	mW	

Table 105. Absolute Maximum Ratings (Continued)

Parameter	Minimum	Maximum	Units	Notes
Maximum current into V _{DD} or out of V _{SS}		140	mA	
64-Pin LQFP Maximum Ratings at –40 °C to 70 °C				
Total power dissipation		1000	mW	
Maximum current into V _{DD} or out of V _{SS}		275	mA	
64-Pin LQFP Maximum Ratings at 70 °C to 125 °C				
Total power dissipation		540	mW	
Maximum current into V _{DD} or out of V _{SS}		150	mA	
44-Pin PLCC Maximum Ratings at –40 °C to 70 °C				
Total power dissipation		750	mW	
Maximum current into V _{DD} or out of V _{SS}		200	mA	
44-Pin PLCC Maximum Ratings at 70 °C to 125 °C				
Total power dissipation		295	mW	
Maximum current into V _{DD} or out of V _{SS}		83	mA	
44-Pin LQFP Maximum Ratings at –40 °C to 70 °C				
Total power dissipation		750	mW	
Maximum current into V _{DD} or out of V _{SS}		200	mA	
44-Pin LQFP Maximum Ratings at 70 °C to 125 °C				
Total power dissipation		360	mW	
Maximum current into V _{DD} or out of V _{SS}		100	mA	
40-Pin PDIP Maximum Ratings at –40 °C to 70 °C				
Total power dissipation		1000	mW	
Maximum current into V _{DD} or out of V _{SS}		275	mA	
40-Pin PDIP Maximum Ratings at 70 °C to 125 °C				
Total power dissipation		540	mW	
Maximum current into V _{DD} or out of V _{SS}		150	mA	
Note: This voltage applies to all pins except the following: VDD, AVDD, pins supporting analog input (Ports B and H), RESET, and where noted otherwise.				

DC Characteristics

Table 106 lists the DC characteristics of the 64K Series products. All voltages are referenced to V_{SS} , the primary system ground.

Table 106. DC Characteristics

Symbol	Parameter	$T_A = -40\text{ °C to }125\text{ °C}$			Units	Conditions
		Minimum	Typical	Maximum		
V_{DD}	Supply Voltage	3.0	–	3.6	V	
V_{IL1}	Low Level Input Voltage	-0.3	–	$0.3 \cdot V_{DD}$	V	For all input pins except \overline{RESET} , DBG, XIN
V_{IL2}	Low Level Input Voltage	-0.3	–	$0.2 \cdot V_{DD}$	V	For \overline{RESET} , DBG, and XIN.
V_{IH1}	High Level Input Voltage	$0.7 \cdot V_{DD}$	–	5.5	V	Port A, C, D, E, F, and G pins.
V_{IH2}	High Level Input Voltage	$0.7 \cdot V_{DD}$	–	$V_{DD} + 0.3$	V	Port B and H pins.
V_{IH3}	High Level Input Voltage	$0.8 \cdot V_{DD}$	–	$V_{DD} + 0.3$	V	\overline{RESET} , DBG, and XIN pins
V_{OL1}	Low Level Output Voltage Standard Drive	–	–	0.4	V	$I_{OL} = 2\text{ mA}$; $V_{DD} = 3.0\text{ V}$ High Output Drive disabled.
V_{OH1}	High Level Output Voltage Standard Drive	2.4	–	–	V	$I_{OH} = -2\text{ mA}$; $V_{DD} = 3.0\text{ V}$ High Output Drive disabled.
V_{OL2}	Low Level Output Voltage High Drive	–	–	0.6	V	$I_{OL} = 20\text{ mA}$; $V_{DD} = 3.3\text{ V}$ High Output Drive enabled $T_A = -40\text{ °C to }+70\text{ °C}$
V_{OH2}	High Level Output Voltage High Drive	2.4	–	–	V	$I_{OH} = -20\text{ mA}$; $V_{DD} = 3.3\text{ V}$ High Output Drive enabled; $T_A = -40\text{ °C to }+70\text{ °C}$
V_{OL3}	Low Level Output Voltage High Drive	–	–	0.6	V	$I_{OL} = 15\text{ mA}$; $V_{DD} = 3.3\text{ V}$ High Output Drive enabled; $T_A = +70\text{ °C to }+105\text{ °C}$
V_{OH3}	High Level Output Voltage High Drive	2.4	–	–	V	$I_{OH} = 15\text{ mA}$; $V_{DD} = 3.3\text{ V}$ High Output Drive enabled; $T_A = +70\text{ °C to }+105\text{ °C}$
V_{RAM}	RAM Data Retention	0.7	–	–	V	
I_{IL}	Input Leakage Current	-5	–	+5	μA	$V_{DD} = 3.6\text{ V}$; $V_{IN} = V_{DD}$ or V_{SS}^1
I_{TL}	Tri-State Leakage Current	-5	–	+5	μA	$V_{DD} = 3.6\text{ V}$

Table 106. DC Characteristics (Continued)

Symbol	Parameter	T _A = -40 °C to 125 °C			Units	Conditions
		Minimum	Typical	Maximum		
C _{PAD}	GPIO Port Pad Capacitance	–	8.0 ²	–	pF	
C _{XIN}	XIN Pad Capacitance	–	8.0 ²	–	pF	
C _{XOUT}	XOUT Pad Capacitance	–	9.5 ²	–	pF	
I _{PU}	Weak Pull-up Current	30	100	350	mA	V _{DD} = 3.0 - 3.6 V
I _{DDA}	Active Mode Supply Current (See Figure 43 on page 220 and Figure 44 on page 221) GPIO pins configured as outputs	–	11	16 12	mA	V _{DD} = 3.6 V, F _{sysclk} = 20 MHz V _{DD} = 3.3 V
		–	9	11 9	mA	V _{DD} = 3.6 V, F _{sysclk} = 10 MHz V _{DD} = 3.3 V
I _{DDH}	HALT Mode Supply Current (See Figure 45 on page 222 and Figure 46 on page 223) GPIO pins configured as outputs		4	7 5	mA	V _{DD} = 3.6 V, F _{sysclk} = 20 MHz V _{DD} = 3.3 V
		–	3	5 4	mA	V _{DD} = 3.6 V, F _{sysclk} = 10 MHz V _{DD} = 3.3 V

Table 106. DC Characteristics (Continued)

Symbol	Parameter	T _A = -40 °C to 125 °C			Units	Conditions
		Minimum	Typical	Maximum		
I _{DDS}	Stop Mode Supply Current (See Figure 47 and Figure 48) GPIO pins configured as outputs	-	520	700	μA	V _{DD} = 3.6 V, VBO and WDT Enabled
				650		V _{DD} = 3.3 V
		-	10	25	μA	V _{DD} = 3.6 V, T _A = 0 to 70 °C
				20		VBO Disabled WDT Enabled V _{DD} = 3.3 V
-		80	μA	V _{DD} = 3.6 V, T _A = -40 to +105 °C		
		70		VBO Disabled WDT Enabled V _{DD} = 3.3 V		
-		250	μA	V _{DD} = 3.6 V, T _A = -40 to +125 °C		
		150		VBO Disabled WDT Enabled V _{DD} = 3.3 V		

¹This condition excludes all pins that have on-chip pull-ups, when driven Low.

²These values are provided for design guidance only and are not tested in production.

Figure 43 displays the typical active mode current consumption while operating at 25 °C versus the system clock frequency. All GPIO pins are configured as outputs and driven High.

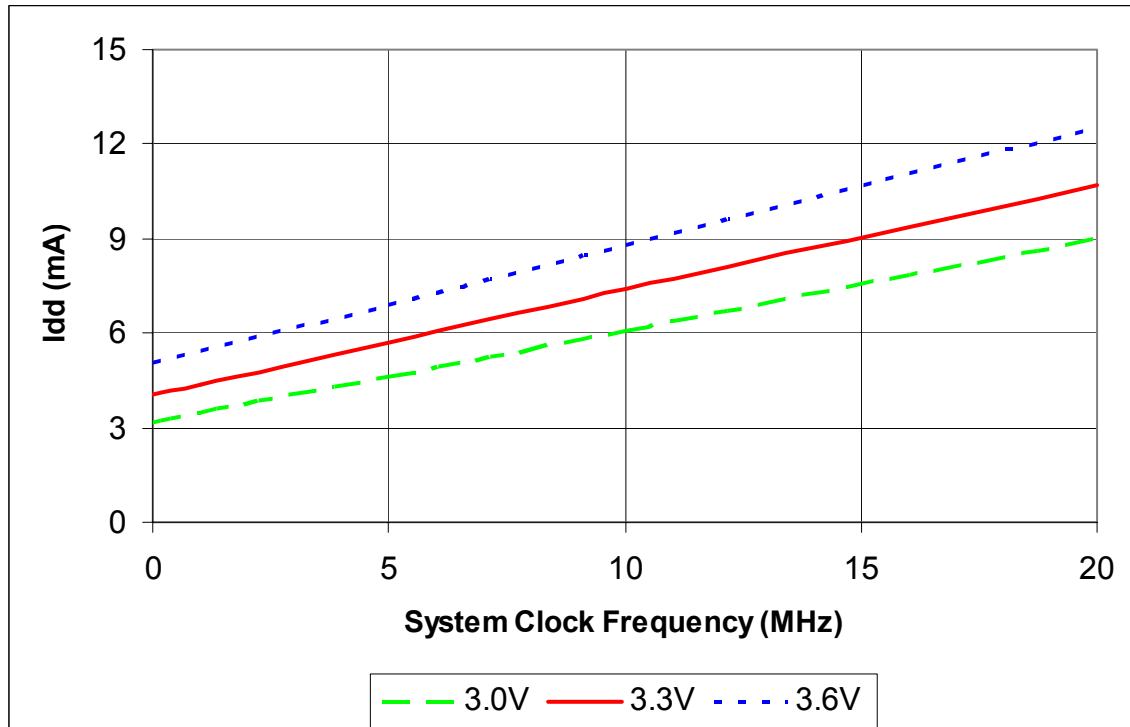

Figure 43. Typical Active Mode I_{dd} Versus System Clock Frequency

Figure 44 displays the maximum active mode current consumption across the full operating temperature range of the device and versus the system clock frequency. All GPIO pins are configured as outputs and driven High.

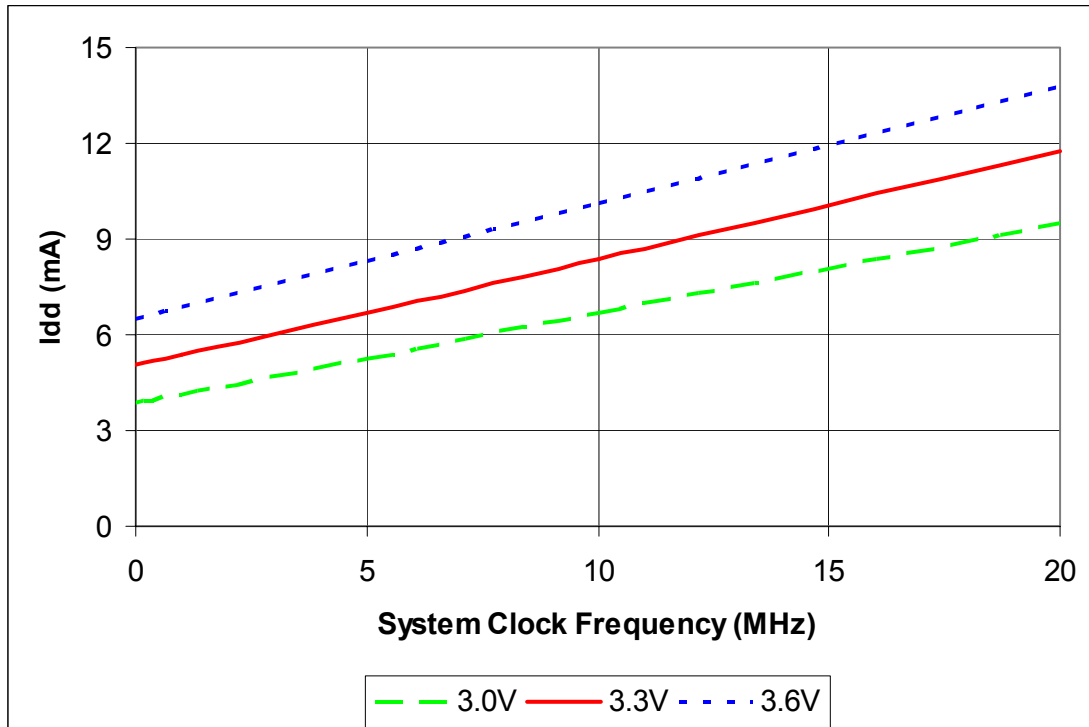

Figure 44. Maximum Active Mode I_{dd} Versus System Clock Frequency

Figure 45 displays the typical current consumption in HALT mode while operating at 25 °C versus the system clock frequency. All GPIO pins are configured as outputs and driven High.

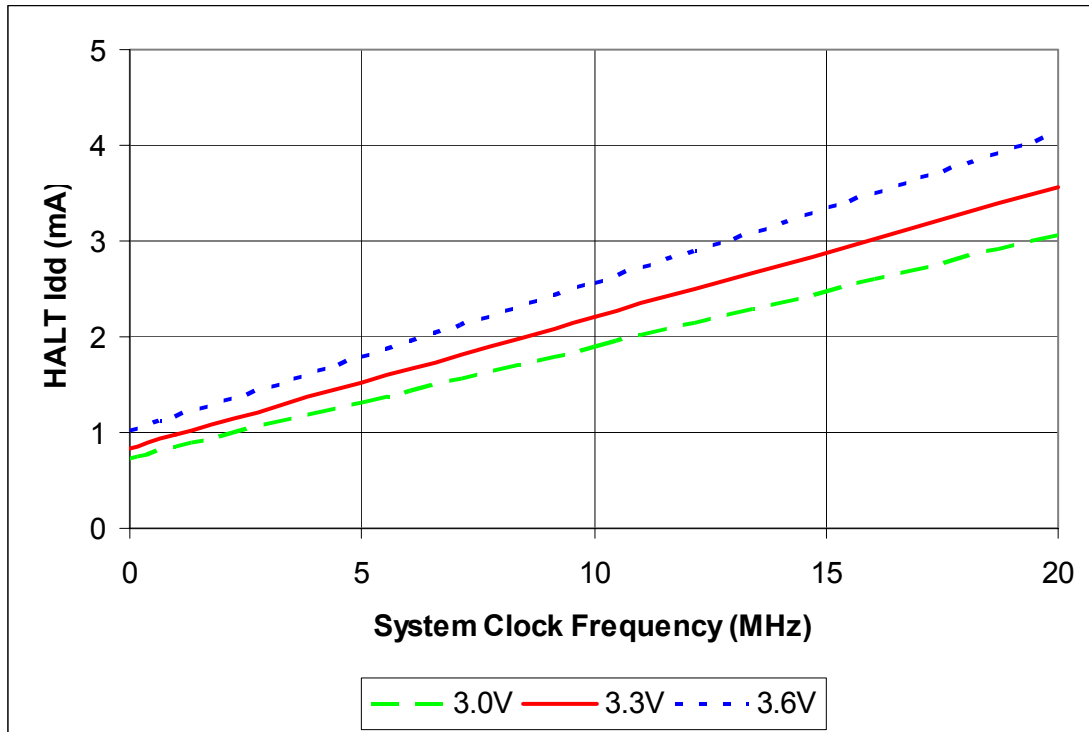

Figure 45. Typical HALT Mode I_{dd} Versus System Clock Frequency

Figure 45 displays the maximum HALT mode current consumption across the full operating temperature range of the device and versus the system clock frequency. All GPIO pins are configured as outputs and driven High.

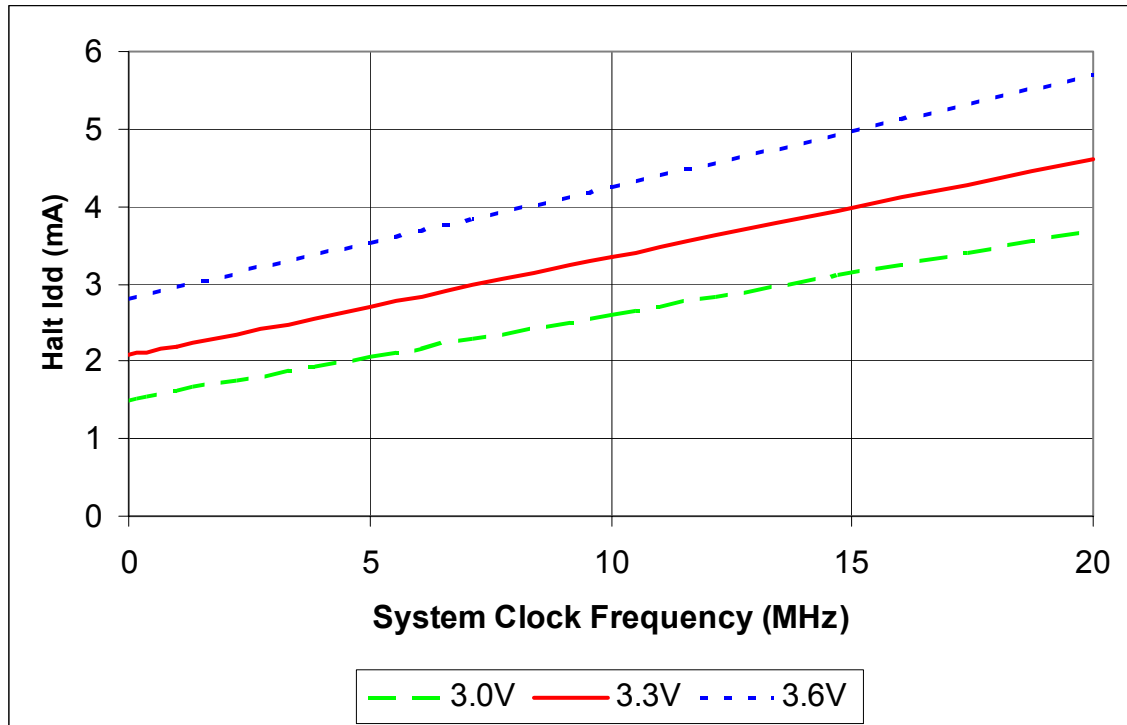

Figure 46. Maximum HALT Mode Icc Versus System Clock Frequency

Figure 47 displays the maximum current consumption in STOP mode with the VBO and Watchdog Timer enabled versus the power supply voltage. All GPIO pins are configured as outputs and driven High.

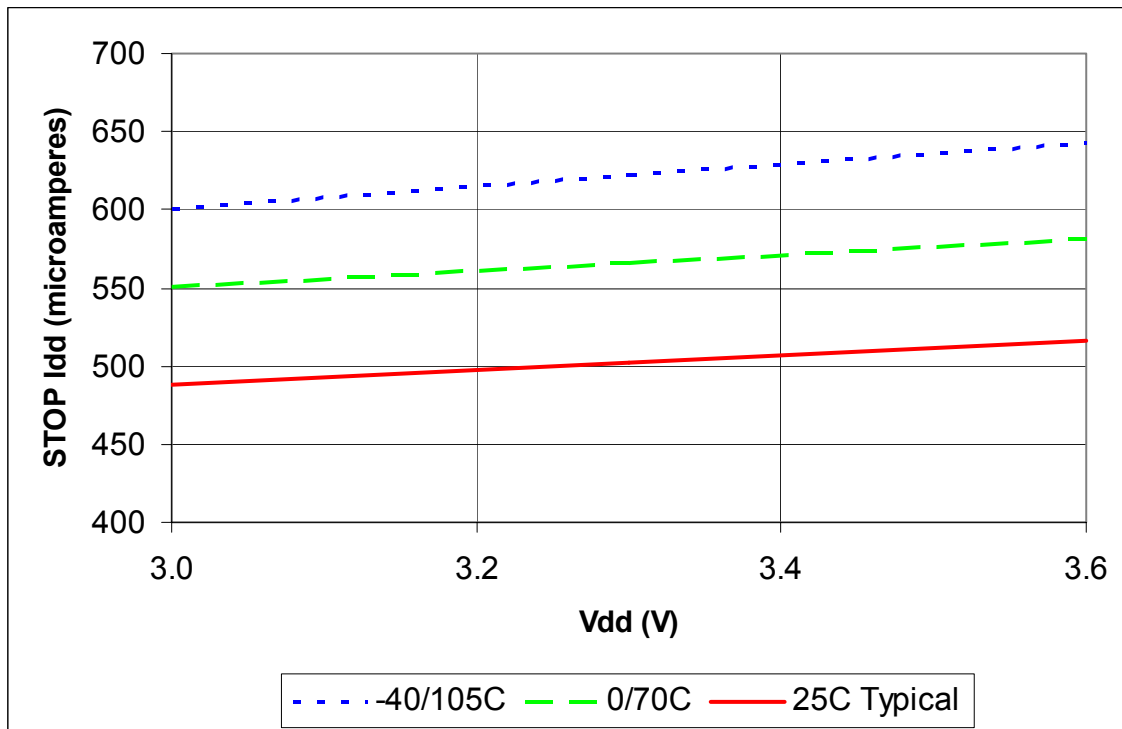

Figure 47. Maximum STOP Mode I_{dd} with VBO enabled versus Power Supply Voltage

Figure 48 displays the maximum current consumption in STOP mode with the VBO disabled and Watchdog Timer enabled versus the power supply voltage. All GPIO pins are configured as outputs and driven High. Disabling the Watchdog Timer and its internal RC oscillator in STOP mode will provide some additional reduction in STOP mode current consumption. This small current reduction would be indistinguishable on the scale of Figure 48.

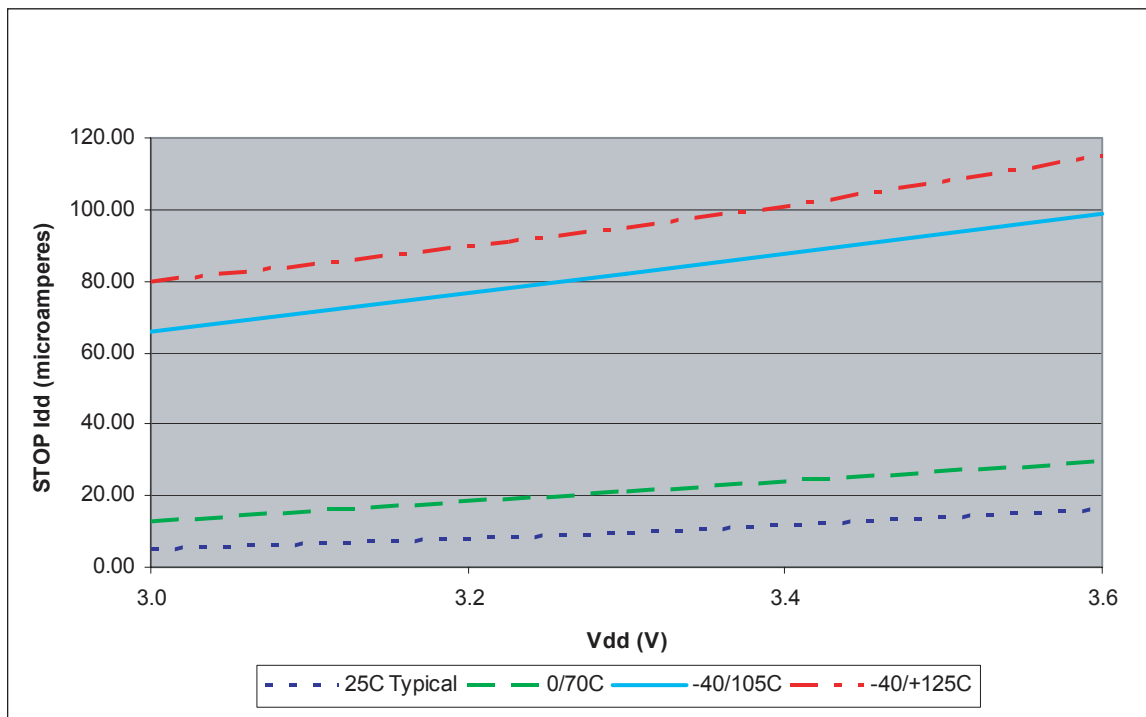

Figure 48. Maximum STOP Mode I_{dd} with VBO Disabled versus Power Supply Voltage

On-Chip Peripheral AC and DC Electrical Characteristics

Table 107. Power-On Reset and Voltage Brownout Electrical Characteristics and Timing

Symbol	Parameter	T _A = -40 °C to 125 °C			Units	Conditions
		Minimum	Typical ¹	Maximum		
V _{POR}	Power-On Reset Voltage Threshold	2.40	2.70	2.90	V	V _{DD} = V _{POR}
V _{VBO}	Voltage Brownout Reset Voltage Threshold	2.30	2.60	2.85	V	V _{DD} = V _{VBO}
	V _{POR} to V _{VBO} hysteresis	50	100	–	mV	
	Starting V _{DD} voltage to ensure valid Power-On Reset.	–	V _{SS}	–	V	
T _{ANA}	Power-On Reset Analog Delay	–	50	–	μs	V _{DD} > V _{POR} ; T _{POR} Digital Reset delay follows T _{ANA}
T _{POR}	Power-On Reset Digital Delay	–	6.6	–	ms	66 WDT Oscillator cycles (10 kHz) + 16 System Clock cycles (20 MHz)
T _{VBO}	Voltage Brownout Pulse Rejection Period	–	10	–	μs	V _{DD} < V _{VBO} to generate a Reset.
T _{RAMP}	Time for V _{DD} to transition from V _{SS} to V _{POR} to ensure valid Reset	0.10	–	100	ms	

¹Data in the typical column is from characterization at 3.3 V and 0 °C. These values are provided for design guidance only and are not tested in production.

Table 108. External RC Oscillator Electrical Characteristics and Timing

Symbol	Parameter	T _A = -40 °C to 125 °C			Units	Conditions
		Minimum	Typical ¹	Maximum		
V _{DD}	Operating Voltage Range	2.70 ¹	–	–	V	
R _{EXT}	External Resistance from XIN to VDD	40	45	200	kΩ	V _{DD} = V _{VBO}
C _{EXT}	External Capacitance from XIN to VSS	0	20	1000	pF	
F _{OSC}	External RC Oscillation Frequency	–	–	4	MHz	

¹When using the external RC oscillator mode, the oscillator may stop oscillating if the power supply drops below 2.7 V, but before the power supply drops to the voltage brown-out threshold. The oscillator will resume oscillation as soon as the supply voltage exceeds 2.7 V.

Table 109. Reset and Stop Mode Recovery Pin Timing

Symbol	Parameter	T _A = -40 °C to 125 °C			Units	Conditions
		Minimum	Typical	Maximum		
T _{RESET}	$\overline{\text{RESET}}$ pin assertion to initiate a system reset.	4	–	–	T _{CLK}	Not in STOP Mode. T _{CLK} = System Clock period.
T _{SMR}	Stop Mode Recovery pin Pulse Rejection Period	10	20	40	ns	$\overline{\text{RESET}}$, DBG, and GPIO pins configured as SMR sources.

Table 110 list the Flash Memory electrical characteristics and timing.

Table 110. Flash Memory Electrical Characteristics and Timing

Parameter	V _{DD} = 3.0–3.6 V T _A = –40 °C to 125 °C			Units	Notes
	Minimum	Typical	Maximum		
Flash Byte Read Time	50	–	–	ns	
Flash Byte Program Time	20	–	40	µs	
Flash Page Erase Time	10	–	–	ms	
Flash Mass Erase Time	200	–	–	ms	
Writes to Single Address Before Next Erase	–	–	2		
Flash Row Program Time	–	–	8	ms	Cumulative program time for single row cannot exceed limit before next erase. This parameter is only an issue when bypassing the Flash Controller.
Data Retention	100	–	–	years	25 °C
Endurance, –40 °C to 105 °C	10,000	–	–	cycles	Program/erase cycles
Endurance, 106 °C to 125 °C	1,000	–	–	cycles	Program/erase cycles

Table 111 lists the Watchdog Timer electrical characteristics and timing.

Table 111. Watchdog Timer Electrical Characteristics and Timing

Symbol	Parameter	V _{DD} = 3.0–3.6 V T _A = –40 °C to 125 °C			Units	Conditions
		Minimum	Typical	Maximum		
F _{WDT}	WDT Oscillator Frequency	5	10	20	kHz	
I _{WDT}	WDT Oscillator Current including internal RC oscillator	–	< 1	5	µA	

Table 112 provides electrical characteristics and timing information for the Analog-to-Digital Converter. Figure 49 displays the input frequency response of the ADC.

Table 112. Analog-to-Digital Converter Electrical Characteristics and Timing

Symbol	Parameter	V _{DD} = 3.0–3.6 V T _A = –40 °C to 125 °C			Units	Conditions
		Minimum	Typical	Maximum		
	Resolution	10	–	–	bits	External V _{REF} = 3.0 V;
	Differential Nonlinearity (DNL)	-1.0		+1.0	lsb	Guaranteed by design
	Integral Nonlinearity (INL)	-3.0	±1.0	3.0	lsb	External V _{REF} = 3.0 V
	DC Offset Error	-35	–	25	mV	
	DC Offset Error	-50	–	25	mV	44-pin LQFP, 44-pin PLCC, and 68-pin PLCC packages.
V _{REF}	Internal Reference Voltage	1.9	2.0	2.4	V	V _{DD} = 3.0 - 3.6 V T _A = -40 °C to 105 °C
VC _{REF}	Voltage Coefficient of Internal Reference Voltage	–	78	–	mV/V	V _{REF} variation as a function of AVDD.
TC _{REF}	Temperature Coefficient of Internal Reference Voltage	–	1	–	mV/°C	
	Single-Shot Conversion Period	–	5129	–	cycles	System clock cycles
	Continuous Conversion Period	–	256	–	cycles	System clock cycles
R _S	Analog Source Impedance	–	–	150	Ω	Recommended
Z _{in}	Input Impedance		150		kΩ	
V _{REF}	External Reference Voltage			AVDD	V	AVDD ≤ VDD. When using an external reference voltage, decoupling capacitance should be placed from VREF to AVSS.
I _{REF}	Current draw into VREF pin when driving with external source.		25.0	40.0	μA	

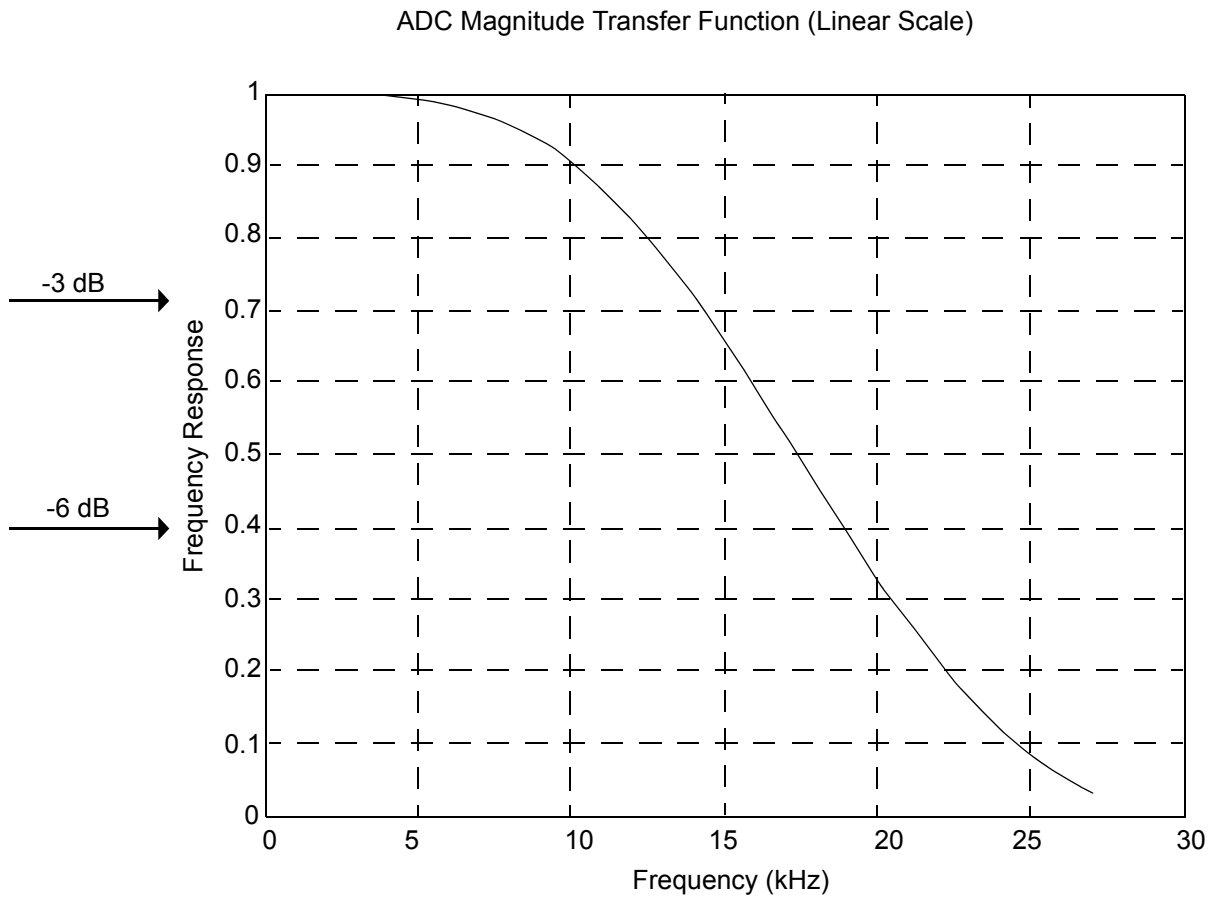

Figure 49. Analog-to-Digital Converter Frequency Response

AC Characteristics

The section provides information on the AC characteristics and timing. All AC timing information assumes a standard load of 50 pF on all outputs. [Table 113](#) lists the 64K Series AC characteristics and timing.

Table 113. AC Characteristics

Symbol	Parameter	$V_{DD} = 3.0\text{--}3.6V$ $T_A = -40\text{ }^\circ\text{C to }125\text{ }^\circ\text{C}$		Units	Conditions
		Minimum	Maximum		
F _{sysclk}	System Clock Frequency	–	20.0	MHz	Read-only from Flash memory.
		0.032768	20.0	MHz	Program or erasure of the Flash memory.
F _{XTAL}	Crystal Oscillator Frequency	0.032768	20.0	MHz	System clock frequencies below the crystal oscillator minimum require an external clock driver.
T _{XIN}	Crystal Oscillator Clock Period	50	–	ns	T _{CLK} = 1/F _{sysclk}
T _{XINH}	System Clock High Time	20		ns	
T _{XINL}	System Clock Low Time	20		ns	
T _{XINR}	System Clock Rise Time	–	3	ns	T _{CLK} = 50 ns. Slower rise times can be tolerated with longer clock periods.
T _{XINF}	System Clock Fall Time	–	3	ns	T _{CLK} = 50 ns. Slower fall times can be tolerated with longer clock periods.

General-Purpose I/O Port Input Data Sample Timing

Figure 50 displays timing of the GPIO Port input sampling. Table 114 lists the GPIO port input timing.

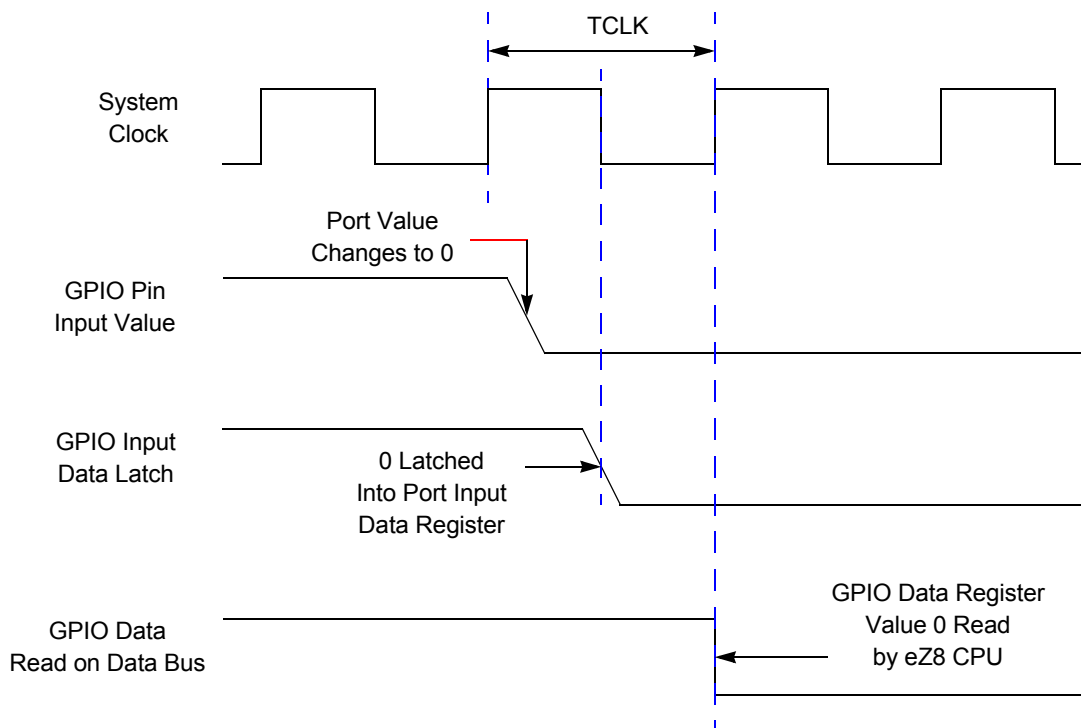

Figure 50. Port Input Sample Timing

Table 114. GPIO Port Input Timing

Parameter	Abbreviation	Delay (ns)	
		Min	Max
T_{S_PORT}	Port Input Transition to XIN Fall Setup Time (Not pictured)	5	–
T_{H_PORT}	XIN Fall to Port Input Transition Hold Time (Not pictured)	6	–
T_{SMR}	GPIO Port Pin Pulse Width to Insure Stop Mode Recovery (for GPIO Port Pins enabled as SMR sources)	1 μ s	

General-Purpose I/O Port Output Timing

Figure 51 and Table 115 provide timing information for GPIO Port pins.

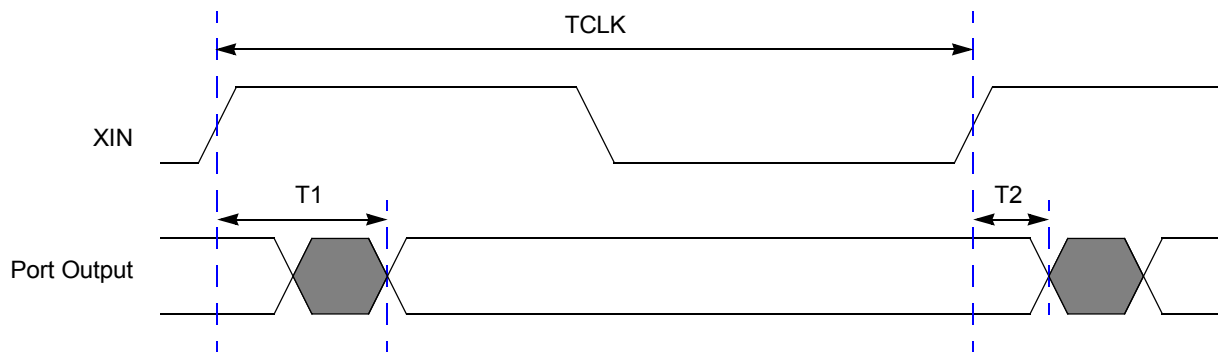

Figure 51. GPIO Port Output Timing

Table 115. GPIO Port Output Timing

Parameter	Abbreviation	Delay (ns)	
		Minimum	Maximum
GPIO Port pins			
T ₁	XIN Rise to Port Output Valid Delay	–	20
T ₂	XIN Rise to Port Output Hold Time	2	–

On-Chip Debugger Timing

Figure 52 and Table 116 provide timing information for the DBG pin. The DBG pin timing specifications assume a 4 μ s maximum rise and fall time.

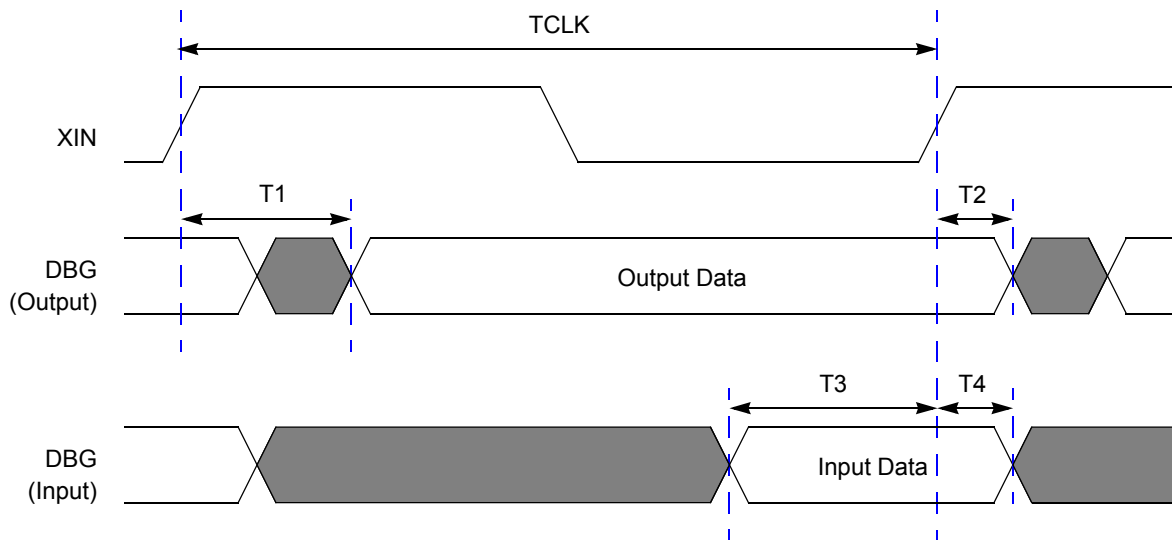

Figure 52. On-Chip Debugger Timing

Table 116. On-Chip Debugger Timing

Parameter	Abbreviation	Delay (ns)	
		Minimum	Maximum
DBG			
T ₁	XIN Rise to DBG Valid Delay	–	30
T ₂	XIN Rise to DBG Output Hold Time	2	–
T ₃	DBG to XIN Rise Input Setup Time	10	–
T ₄	DBG to XIN Rise Input Hold Time	5	–
	DBG frequency	System Clock/4	

SPI Master Mode Timing

Figure 53 and Table 117 provide timing information for SPI Master mode pins. Timing is shown with SCK rising edge used to source MOSI output data, SCK falling edge used to sample MISO input data. Timing on the SS output pin(s) is controlled by software.

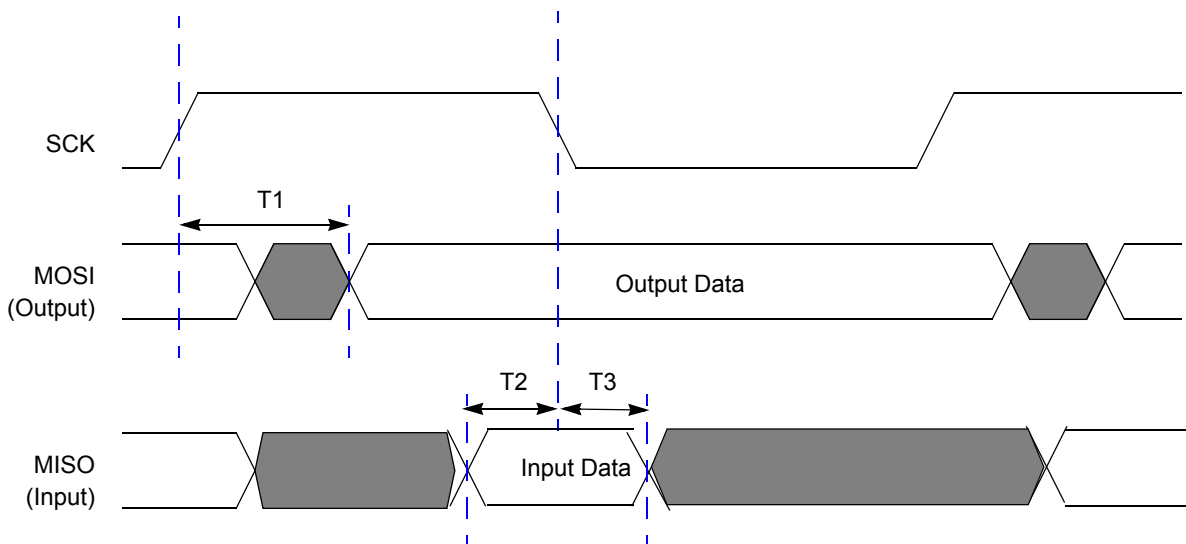

Figure 53. SPI Master Mode Timing

Table 117. SPI Master Mode Timing

Parameter	Abbreviation	Delay (ns)	
		Min	Max
SPI Master			
T ₁	SCK Rise to MOSI output Valid Delay	-5	+5
T ₂	MISO input to SCK (receive edge) Setup Time	20	
T ₃	MISO input to SCK (receive edge) Hold Time	0	

SPI Slave Mode Timing

Figure 54 and Table 118 provide timing information for the SPI slave mode pins. Timing is shown with SCK rising edge used to source MISO output data, SCK falling edge used to sample MOSI input data.

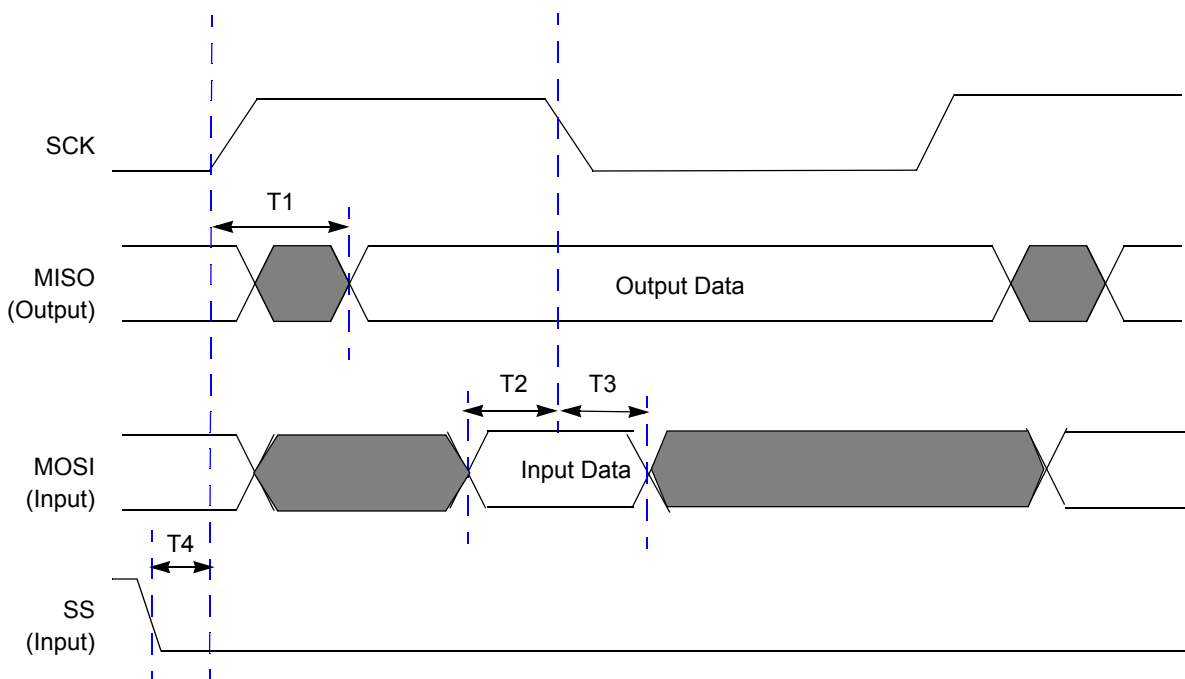

Figure 54. SPI Slave Mode Timing

Table 118. SPI Slave Mode Timing

Parameter	Abbreviation	Delay (ns)	
		Minimum	Maximum
SPI Slave			
T ₁	SCK (transmit edge) to MISO output Valid Delay	2 * X _{in} period	3 * X _{in} period + 20 nsec
T ₂	MOSI input to SCK (receive edge) Setup Time	0	
T ₃	MOSI input to SCK (receive edge) Hold Time	3 * X _{in} period	
T ₄	SS input assertion to SCK setup	1 * X _{in} period	

I²C Timing

Figure 55 and Table 119 provide timing information for I²C pins.

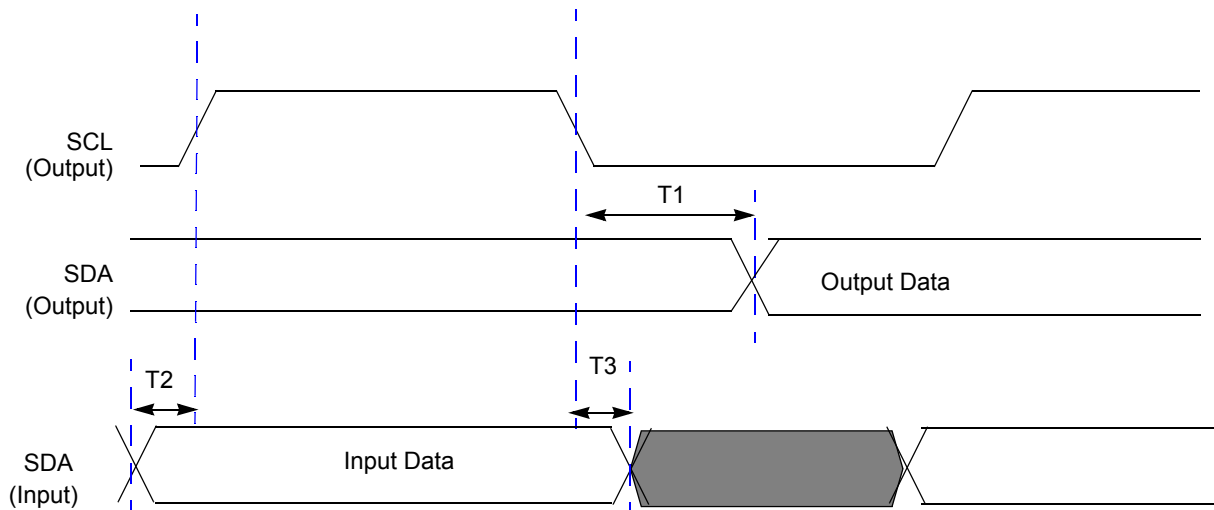

Figure 55. I²C Timing

Table 119. I²C Timing

Parameter	Abbreviation	Delay (ns)	
		Minimum	Maximum
I²C			
T ₁	SCL Fall to SDA output delay	SCL period/4	
T ₂	SDA Input to SCL rising edge Setup Time	0	
T ₃	SDA Input to SCL falling edge Hold Time	0	

UART Timing

Figure 56 and Table 120 provide timing information for UART pins for the case where the Clear To Send input pin ($\overline{\text{CTS}}$) is used for flow control. In this example, it is assumed that the Driver Enable polarity has been configured to be Active Low and is represented here by $\overline{\text{DE}}$. The $\overline{\text{CTS}}$ to $\overline{\text{DE}}$ assertion delay (T_1) assumes the UART Transmit Data register has been loaded with data prior to $\overline{\text{CTS}}$ assertion.

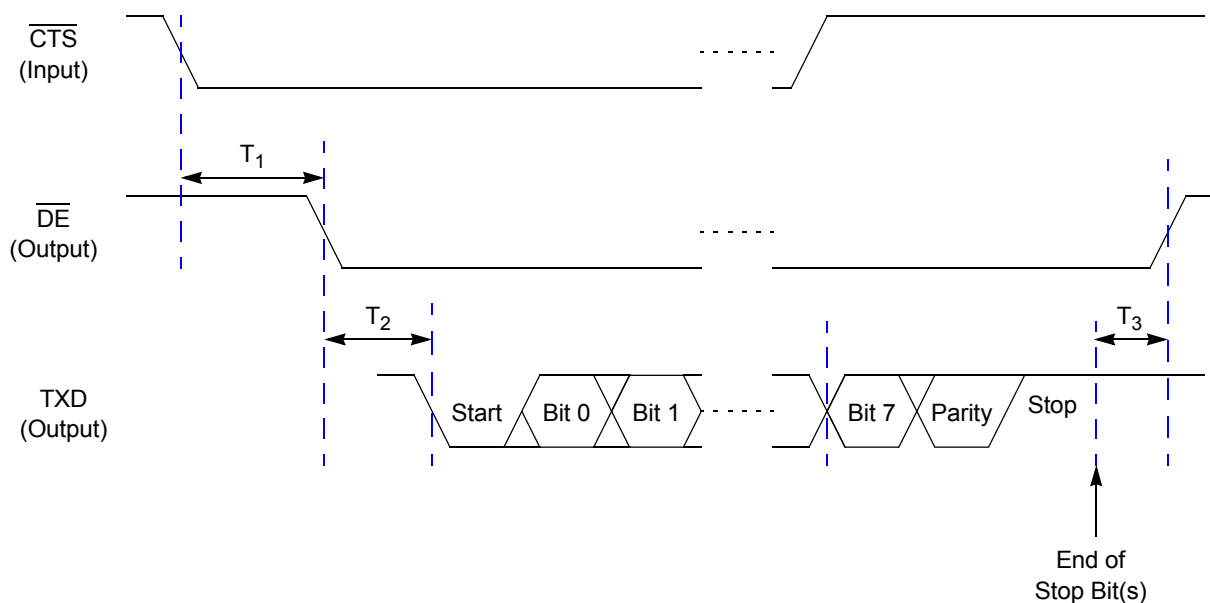

Figure 56. UART Timing with $\overline{\text{CTS}}$

Table 120. UART Timing with $\overline{\text{CTS}}$

Parameter	Abbreviation	Delay (ns)	
		Minimum	Maximum
T_1	$\overline{\text{CTS}}$ Fall to $\overline{\text{DE}}$ Assertion Delay	2 * XIN period	2 * XIN period + 1 Bit period
T_2	$\overline{\text{DE}}$ Assertion to TXD Falling Edge (Start) Delay	1 Bit period	1 Bit period + 1 * XIN period
T_3	End of Stop Bit(s) to $\overline{\text{DE}}$ Deassertion Delay	1 * XIN period	2 * XIN period

Figure 57 and Table 121 provide timing information for UART pins for the case where the Clear To Send input signal ($\overline{\text{CTS}}$) is not used for flow control. In this example, it is assumed that the Driver Enable polarity has been configured to be Active Low and is represented here by $\overline{\text{DE}}$. $\overline{\text{DE}}$ asserts after the UART Transmit Data Register has been written. $\overline{\text{DE}}$ remains asserted for multiple characters as long as the Transmit Data register is written with the next character before the current character has completed.

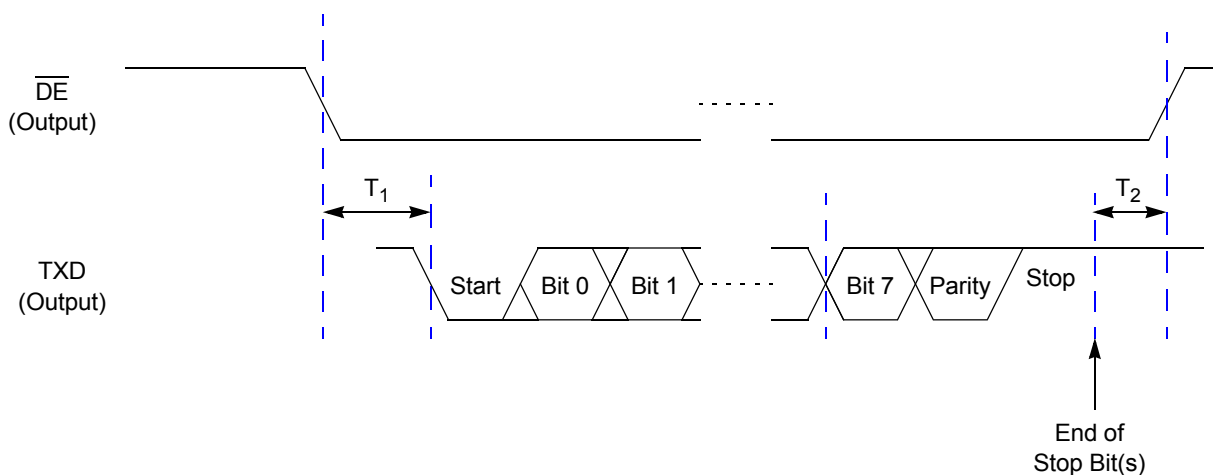

Figure 57. UART Timing without $\overline{\text{CTS}}$

Table 121. UART Timing without $\overline{\text{CTS}}$

Parameter	Abbreviation	Delay (ns)	
		Minimum	Maximum
T_1	$\overline{\text{DE}}$ Assertion to TXD Falling Edge (Start) Delay	1 Bit period	1 Bit period + 1 * XIN period
T_2	End of Stop Bit(s) to $\overline{\text{DE}}$ Deassertion Delay	1 * XIN period	2 * XIN period



eZ8[™] CPU Instruction Set

Assembly Language Programming Introduction

The eZ8 CPU assembly language provides a means for writing an application program without having to be concerned with actual memory addresses or machine instruction formats. A program written in assembly language is called a source program. Assembly language allows the use of symbolic addresses to identify memory locations. It also allows mnemonic codes (opcodes and operands) to represent the instructions themselves. The opcodes identify the instruction while the operands represent memory locations, registers, or immediate data values.

Each assembly language program consists of a series of symbolic commands called statements. Each statement can contain labels, operations, operands and comments.

Labels can be assigned to a particular instruction step in a source program. The label identifies that step in the program as an entry point for use by other instructions.

The assembly language also includes assembler directives that supplement the machine instruction. The assembler directives, or pseudo-ops, are not translated into a machine instruction. Rather, the pseudo-ops are interpreted as directives that control or assist the assembly process.

The source program is processed (assembled) by the assembler to obtain a machine language program called the object code. The object code is executed by the eZ8 CPU. An example segment of an assembly language program is detailed in the following example.

Assembly Language Source Program Example

```
JP START      ; Everything after the semicolon is a comment.

START:        ; A label called "START". The first instruction (JP START) in this
              ; example causes program execution to jump to the point within the
              ; program where the START label occurs.

LD R4, R7     ; A Load (LD) instruction with two operands. The first operand,
              ; Working Register R4, is the destination. The second operand,
              ; Working Register R7, is the source. The contents of R7 is
              ; written into R4.

LD 234H, #%01 ; Another Load (LD) instruction with two operands.
              ; The first operand, Extended Mode Register Address 234H,
              ; identifies the destination. The second operand, Immediate Data
```

; value 01H, is the source. The value 01H is written into the
; Register at address 234H.

Assembly Language Syntax

For proper instruction execution, eZ8 CPU assembly language syntax requires that the operands be written as ‘destination, source’. After assembly, the object code usually has the operands in the order ‘source, destination’, but ordering is opcode-dependent. The following instruction examples illustrate the format of some basic assembly instructions and the resulting object code produced by the assembler. This binary format must be followed if you prefer manual program coding or intend to implement your own assembler.

Example 1: If the contents of Registers 43H and 08H are added and the result is stored in 43H, the assembly syntax and resulting object code is:

Assembly Language Syntax Example 1

Assembly Language Code	ADD	43H,	08H	(ADD dst, src)
Object Code	04	08	43	(OPC src, dst)

Example 2: In general, when an instruction format requires an 8-bit register address, that address can specify any register location in the range 0–255 or, using Escaped Mode Addressing, a Working Register R0 - R15. If the contents of Register 43H and Working Register R8 are added and the result is stored in 43H, the assembly syntax and resulting object code is:

Assembly Language Syntax Example 2

Assembly Language Code	ADD	43H,	R8	(ADD dst, src)
Object Code	04	E8	43	(OPC src, dst)

Refer to the device-specific Product Specification to determine the exact register file range available. The register file size varies, depending on the device type.

eZ8 CPU Instruction Notation

In the eZ8 CPU Instruction Summary and Description sections, the operands, condition codes, status Flags, and address modes are represented by a notational shorthand that is described in [Table 122](#).

Table 122. Notational Shorthand

Notation	Description	Operand	Range
b	Bit	b	b represents a value from 0 to 7 (000B to 111B).
cc	Condition Code	—	Refer to Condition Codes overview in the eZ8 CPU User Manual.
DA	Direct Address	Addr	Addr. represents a number in the range of 0000H to FFFFH
ER	Extended Addressing Register	Reg	Reg. represents a number in the range of 000H to FFFH
IM	Immediate Data	#Data	Data is a number between 00H to FFH
Ir	Indirect Working Register	@Rn	n = 0 – 15
IR	Indirect Register	@Reg	Reg. represents a number in the range of 00H to FFH
Irr	Indirect Working Register Pair	@RRp	p = 0, 2, 4, 6, 8, 10, 12, or 14
IRR	Indirect Register Pair	@Reg	Reg. represents an even number in the range 00H to FEH
p	Polarity	p	Polarity is a single bit binary value of either 0B or 1B.
r	Working Register	Rn	n = 0 – 15
R	Register	Reg	Reg. represents a number in the range of 00H to FFH
RA	Relative Address	X	X represents an index in the range of +127 to -128 which is an offset relative to the address of the next instruction
rr	Working Register Pair	RRp	p = 0, 2, 4, 6, 8, 10, 12, or 14
RR	Register Pair	Reg	Reg. represents an even number in the range of 00H to FEH
Vector	Vector Address	Vector	Vector represents a number in the range of 00H to FFH
X	Indexed	#Index	The register or register pair to be indexed is offset by the signed Index value (#Index) in a +127 to -128 range.

Table 123 contains additional symbols that are used throughout the Instruction Summary and Instruction Set Description sections.

Table 123. Additional Symbols

Symbol	Definition
dst	Destination Operand
src	Source Operand
@	Indirect Address Prefix
SP	Stack Pointer
PC	Program Counter
FLAGS	Flags Register
RP	Register Pointer
#	Immediate Operand Prefix
B	Binary Number Suffix
%	Hexadecimal Number Prefix
H	Hexadecimal Number Suffix

Assignment of a value is indicated by an arrow. For example,

$$\text{dst} \leftarrow \text{dst} + \text{src}$$

indicates the source data is added to the destination data and the result is stored in the destination location.

Condition Codes

The C, Z, S and V Flags control the operation of the conditional jump (JP cc and JR cc) instructions. Sixteen frequently useful functions of the Flag settings are encoded in a 4-bit field called the condition code (cc), which forms Bits 7:4 of the conditional jump instructions. The condition codes are summarized in [Table 124](#). Some binary condition codes can be created using more than one assembly code mnemonic. The result of the Flag test operation decides if the conditional jump is executed.

Table 124. Condition Codes

Binary	Hex	Assembly Mnemonic	Definition	Flag Test Operation
0000	0	F	Always False	–
0001	1	LT	Less Than	(S XOR V) = 1
0010	2	LE	Less Than or Equal	(Z OR (S XOR V)) = 1

Table 124. Condition Codes (Continued)

Binary	Hex	Assembly Mnemonic	Definition	Flag Test Operation
0011	3	ULE	Unsigned Less Than or Equal	(C OR Z) = 1
0100	4	OV	Overflow	V = 1
0101	5	MI	Minus	S = 1
0110	6	Z	Zero	Z = 1
0110	6	EQ	Equal	Z = 1
0111	7	C	Carry	C = 1
0111	7	ULT	Unsigned Less Than	C = 1
1000	8	T (or blank)	Always True	–
1001	9	GE	Greater Than or Equal	(S XOR V) = 0
1010	A	GT	Greater Than	(Z OR (S XOR V)) = 0
1011	B	UGT	Unsigned Greater Than	(C = 0 AND Z = 0) = 1
1100	C	NOV	No Overflow	V = 0
1101	D	PL	Plus	S = 0
1110	E	NZ	Non-Zero	Z = 0
1110	E	NE	Not Equal	Z = 0
1111	F	NC	No Carry	C = 0
1111	F	UGE	Unsigned Greater Than or Equal	C = 0

eZ8 CPU Instruction Classes

eZ8 CPU instructions can be divided functionally into the following groups:

- Arithmetic
- Bit Manipulation
- Block Transfer
- CPU Control
- Load
- Logical
- Program Control
- Rotate and Shift

Table 125 through Table 132 contain the instructions belonging to each group and the number of operands required for each instruction. Some instructions appear in more than one table as these instruction can be considered as a subset of more than one category. Within these tables, the source operand is identified as 'src', the destination operand is 'dst' and a condition code is 'cc'.

Table 125. Arithmetic Instructions

Mnemonic	Operands	Instruction
ADC	dst, src	Add with Carry
ADCX	dst, src	Add with Carry using Extended Addressing
ADD	dst, src	Add
ADDX	dst, src	Add using Extended Addressing
CP	dst, src	Compare
CPC	dst, src	Compare with Carry
CPCX	dst, src	Compare with Carry using Extended Addressing
CPX	dst, src	Compare using Extended Addressing
DA	dst	Decimal Adjust
DEC	dst	Decrement
DECW	dst	Decrement Word
INC	dst	Increment
INCW	dst	Increment Word
MULT	dst	Multiply
SBC	dst, src	Subtract with Carry
SBCX	dst, src	Subtract with Carry using Extended Addressing
SUB	dst, src	Subtract
SUBX	dst, src	Subtract using Extended Addressing

Table 126. Bit Manipulation Instructions

Mnemonic	Operands	Instruction
BCLR	bit, dst	Bit Clear
BIT	p, bit, dst	Bit Set or Clear
BSET	bit, dst	Bit Set

Table 126. Bit Manipulation Instructions (Continued)

Mnemonic	Operands	Instruction
BSWAP	dst	Bit Swap
CCF	—	Complement Carry Flag
RCF	—	Reset Carry Flag
SCF	—	Set Carry Flag
TCM	dst, src	Test Complement Under Mask
TCMX	dst, src	Test Complement Under Mask using Extended Addressing
TM	dst, src	Test Under Mask
TMX	dst, src	Test Under Mask using Extended Addressing

Table 127. Block Transfer Instructions

Mnemonic	Operands	Instruction
LDCI	dst, src	Load Constant to/from Program Memory and Auto-Increment Addresses
LDEI	dst, src	Load External Data to/from Data Memory and Auto-Increment Addresses

Table 128. CPU Control Instructions

Mnemonic	Operands	Instruction
ATM	—	Atomic Execution
CCF	—	Complement Carry Flag
DI	—	Disable Interrupts
EI	—	Enable Interrupts
HALT	—	HALT Mode
NOP	—	No Operation
RCF	—	Reset Carry Flag
SCF	—	Set Carry Flag
SRP	src	Set Register Pointer

Table 128. CPU Control Instructions

Mnemonic	Operands	Instruction
STOP	—	STOP Mode
WDT	—	Watchdog Timer Refresh

Table 129. Load Instructions

Mnemonic	Operands	Instruction
CLR	dst	Clear
LD	dst, src	Load
LDC	dst, src	Load Constant to/from Program Memory
LDCI	dst, src	Load Constant to/from Program Memory and Auto-Increment Addresses
LDE	dst, src	Load External Data to/from Data Memory
LDEI	dst, src	Load External Data to/from Data Memory and Auto-Increment Addresses
LDWX	dst, src	Load Word using Extended Addressing
LDX	dst, src	Load using Extended Addressing
LEA	dst, X(src)	Load Effective Address
POP	dst	Pop
POPX	dst	Pop using Extended Addressing
PUSH	src	Push
PUSHX	src	Push using Extended Addressing

Table 130. Logical Instructions

Mnemonic	Operands	Instruction
AND	dst, src	Logical AND
ANDX	dst, src	Logical AND using Extended Addressing
COM	dst	Complement
OR	dst, src	Logical OR
ORX	dst, src	Logical OR using Extended Addressing

Table 130. Logical Instructions (Continued)

Mnemonic	Operands	Instruction
XOR	dst, src	Logical Exclusive OR
XORX	dst, src	Logical Exclusive OR using Extended Addressing

Table 131. Program Control Instructions

Mnemonic	Operands	Instruction
BRK	—	On-Chip Debugger Break
BTJ	p, bit, src, DA	Bit Test and Jump
BTJNZ	bit, src, DA	Bit Test and Jump if Non-Zero
BTJZ	bit, src, DA	Bit Test and Jump if Zero
CALL	dst	Call Procedure
DJNZ	dst, src, RA	Decrement and Jump Non-Zero
IRET	—	Interrupt Return
JP	dst	Jump
JP cc	dst	Jump Conditional
JR	DA	Jump Relative
JR cc	DA	Jump Relative Conditional
RET	—	Return
TRAP	vector	Software Trap

Table 132. Rotate and Shift Instructions

Mnemonic	Operands	Instruction
BSWAP	dst	Bit Swap
RL	dst	Rotate Left
RLC	dst	Rotate Left through Carry
RR	dst	Rotate Right
RRC	dst	Rotate Right through Carry
SRA	dst	Shift Right Arithmetic



Table 132. Rotate and Shift Instructions (Continued)

Mnemonic	Operands	Instruction
SRL	dst	Shift Right Logical
SWAP	dst	Swap Nibbles

eZ8 CPU Instruction Summary

Table 133 summarizes the eZ8 CPU instructions. The table identifies the addressing modes employed by the instruction, the effect upon the Flags register, the number of CPU clock cycles required for the instruction fetch, and the number of CPU clock cycles required for the instruction execution.

Table 133. eZ8 CPU Instruction Summary

Assembly Mnemonic	Symbolic Operation	Address Mode		Opcode(s) (Hex)	Flags						Fetch Cycles	Instr. Cycles
		dst	src		C	Z	S	V	D	H		
ADC dst, src	$dst \leftarrow dst + src + C$	r	r	12	*	*	*	*	0	*	2	3
		r	lr	13							2	4
		R	R	14							3	3
		R	IR	15							3	4
		R	IM	16							3	3
		IR	IM	17							3	4
ADCX dst, src	$dst \leftarrow dst + src + C$	ER	ER	18	*	*	*	*	0	*	4	3
		ER	IM	19							4	3
ADD dst, src	$dst \leftarrow dst + src$	r	r	02	*	*	*	*	0	*	2	3
		r	lr	03							2	4
		R	R	04							3	3
		R	IR	05							3	4
		R	IM	06							3	3
		IR	IM	07							3	4
ADDX dst, src	$dst \leftarrow dst + src$	ER	ER	08	*	*	*	*	0	*	4	3
		ER	IM	09							4	3



Table 133. eZ8 CPU Instruction Summary (Continued)

Assembly Mnemonic	Symbolic Operation	Address Mode		Opcode(s) (Hex)	Flags						Fetch Cycles	Instr. Cycles
		dst	src		C	Z	S	V	D	H		
AND dst, src	dst ← dst AND src	r	r	52	-	*	*	0	-	-	2	3
		r	lr	53							2	4
		R	R	54							3	3
		R	IR	55							3	4
		R	IM	56							3	3
		IR	IM	57							3	4
ANDX dst, src	dst ← dst AND src	ER	ER	58	-	*	*	0	-	-	4	3
		ER	IM	59							4	3
ATM	Block all interrupt and DMA requests during execution of the next 3 instructions			2F	-	-	-	-	-	-	1	2
BCLR bit, dst	dst[bit] ← 0	r		E2	-	*	*	0	-	-	2	2
BIT p, bit, dst	dst[bit] ← p	r		E2	-	*	*	0	-	-	2	2
BRK	Debugger Break			00	-	-	-	-	-	-	1	1
BSET bit, dst	dst[bit] ← 1	r		E2	-	*	*	0	-	-	2	2
BSWAP dst	dst[7:0] ← dst[0:7]	R		D5	X	*	*	0	-	-	2	2
BTJ p, bit, src, dst	if src[bit] = p PC ← PC + X		r	F6	-	-	-	-	-	-	3	3
			lr	F7							3	4
BTJNZ bit, src, dst	if src[bit] = 1 PC ← PC + X		r	F6	-	-	-	-	-	-	3	3
			lr	F7							3	4
BTJZ bit, src, dst	if src[bit] = 0 PC ← PC + X		r	F6	-	-	-	-	-	-	3	3
			lr	F7							3	4
CALL dst	SP ← SP -2 @SP ← PC PC ← dst	IRR		D4	-	-	-	-	-	-	2	6
		DA		D6							3	3
CCF	C ← ~C			EF	*	-	-	-	-	-	1	2
CLR dst	dst ← 00H	R		B0	-	-	-	-	-	-	2	2
		IR		B1							2	3



Table 133. eZ8 CPU Instruction Summary (Continued)

Assembly Mnemonic	Symbolic Operation	Address Mode		Opcode(s) (Hex)	Flags						Fetch Cycles	Instr. Cycles
		dst	src		C	Z	S	V	D	H		
COM dst	dst ← ~dst	R		60	-	*	*	0	-	-	2	2
		IR		61							2	3
CP dst, src	dst - src	r	r	A2	*	*	*	*	-	-	2	3
		r	lr	A3							2	4
		R	R	A4							3	3
		R	IR	A5							3	4
		R	IM	A6							3	3
		IR	IM	A7							3	4
CPC dst, src	dst - src - C	r	r	1F A2	*	*	*	*	-	-	3	3
		r	lr	1F A3							3	4
		R	R	1F A4							4	3
		R	IR	1F A5							4	4
		R	IM	1F A6							4	3
		IR	IM	1F A7							4	4
CPCX dst, src	dst - src - C	ER	ER	1F A8	*	*	*	*	-	-	5	3
		ER	IM	1F A9							5	3
CPX dst, src	dst - src	ER	ER	A8	*	*	*	*	-	-	4	3
		ER	IM	A9							4	3
DA dst	dst ← DA(dst)	R		40	*	*	*	X	-	-	2	2
		IR		41							2	3
DEC dst	dst ← dst - 1	R		30	-	*	*	*	-	-	2	2
		IR		31							2	3
DECW dst	dst ← dst - 1	RR		80	-	*	*	*	-	-	2	5
		IRR		81							2	6
DI	IRQCTL[7] ← 0			8F	-	-	-	-	-	-	1	2
DJNZ dst, RA	dst ← dst - 1 if dst ≠ 0 PC ← PC + X	r		0A-FA	-	-	-	-	-	-	2	3



Table 133. eZ8 CPU Instruction Summary (Continued)

Assembly Mnemonic	Symbolic Operation	Address Mode		Opcode(s) (Hex)	Flags						Fetch Cycles	Instr. Cycles
		dst	src		C	Z	S	V	D	H		
EI	IRQCTL[7] ← 1			9F	-	-	-	-	-	-	1	2
HALT	HALT Mode			7F	-	-	-	-	-	-	1	2
INC dst	dst ← dst + 1	R		20	-	*	*	*	-	-	2	2
		IR		21							2	3
		r		0E-FE							1	2
INCW dst	dst ← dst + 1	RR		A0	-	*	*	*	-	-	2	5
		IRR		A1							2	6
IRET	FLAGS ← @SP SP ← SP + 1 PC ← @SP SP ← SP + 2 IRQCTL[7] ← 1			BF	*	*	*	*	*	*	1	5
JP dst	PC ← dst	DA		8D	-	-	-	-	-	-	3	2
		IRR		C4							2	3
JP cc, dst	if cc is true PC ← dst	DA		0D-FD	-	-	-	-	-	-	3	2
JR dst	PC ← PC + X	DA		8B	-	-	-	-	-	-	2	2
JR cc, dst	if cc is true PC ← PC + X	DA		0B-FB	-	-	-	-	-	-	2	2
LD dst, rc	dst ← src	r	IM	0C-FC	-	-	-	-	-	-	2	2
		r	X(r)	C7							3	3
		X(r)	r	D7							3	4
		r	lr	E3							2	3
		R	R	E4							3	2
		R	IR	E5							3	4
		R	IM	E6							3	2
		IR	IM	E7							3	3
		lr	r	F3							2	3
IR	R	F5							3	3		



Table 133. eZ8 CPU Instruction Summary (Continued)

Assembly Mnemonic	Symbolic Operation	Address Mode		Opcode(s) (Hex)	Flags						Fetch Cycles	Instr. Cycles
		dst	src		C	Z	S	V	D	H		
LDC dst, src	dst ← src	r	lrr	C2	-	-	-	-	-	-	2	5
		lr	lrr	C5							2	9
		lrr	r	D2							2	5
LDCI dst, src	dst ← src r ← r + 1 rr ← rr + 1	lr	lrr	C3	-	-	-	-	-	-	2	9
		lrr	lr	D3							2	9
LDE dst, src	dst ← src	r	lrr	82	-	-	-	-	-	-	2	5
		lrr	r	92							2	5
LDEI dst, src	dst ← src r ← r + 1 rr ← rr + 1	lr	lrr	83	-	-	-	-	-	-	2	9
		lrr	lr	93							2	9
LDWX dst, src	dst ← src	ER	ER	1F E8	-	-	-	-	-	-	5	4
LDX dst, src	dst ← src	r	ER	84	-	-	-	-	-	-	3	2
		lr	ER	85							3	3
		R	IRR	86							3	4
		IR	IRR	87							3	5
		r	X(rr)	88							3	4
		X(rr)	r	89							3	4
		ER	r	94							3	2
		ER	lr	95							3	3
		IRR	R	96							3	4
		IRR	IR	97							3	5
		ER	ER	E8							4	2
LEA dst, X(src)	dst ← src + X	r	X(r)	98	-	-	-	-	-	-	3	3
		rr	X(rr)	99							3	5
MULT dst	dst[15:0] ← dst[15:8] * dst[7:0]	RR		F4	-	-	-	-	-	-	2	8
NOP	No operation			0F	-	-	-	-	-	-	1	2



Table 133. eZ8 CPU Instruction Summary (Continued)

Assembly Mnemonic	Symbolic Operation	Address Mode		Opcode(s) (Hex)	Flags						Fetch Cycles	Instr. Cycles
		dst	src		C	Z	S	V	D	H		
OR dst, src	dst ← dst OR src	r	r	42	-	*	*	0	-	-	2	3
		r	lr	43							2	4
		R	R	44							3	3
		R	IR	45							3	4
		R	IM	46							3	3
		IR	IM	47							3	4
ORX dst, src	dst ← dst OR src	ER	ER	48	-	*	*	0	-	-	4	3
		ER	IM	49							4	3
POP dst	dst ← @SP SP ← SP + 1	R		50	-	-	-	-	-	-	2	2
		IR		51							2	3
POPX dst	dst ← @SP SP ← SP + 1	ER		D8	-	-	-	-	-	-	3	2
PUSH src	SP ← SP - 1 @SP ← src	R		70	-	-	-	-	-	-	2	2
		IR		71							2	3
		IM		1F 70							3	2
PUSHX src	SP ← SP - 1 @SP ← src	ER		C8	-	-	-	-	-	-	3	2
RCF	C ← 0			CF	0	-	-	-	-	-	1	2
RET	PC ← @SP SP ← SP + 2			AF	-	-	-	-	-	-	1	4
RL dst		R		90	*	*	*	*	-	-	2	2
		IR		91							2	3
RLC dst		R		10	*	*	*	*	-	-	2	2
		IR		11							2	3
RR dst		R		E0	*	*	*	*	-	-	2	2
		IR		E1							2	3



Table 133. eZ8 CPU Instruction Summary (Continued)

Assembly Mnemonic	Symbolic Operation	Address Mode		Opcode(s) (Hex)	Flags						Fetch Cycles	Instr. Cycles
		dst	src		C	Z	S	V	D	H		
RRC dst		R		C0	*	*	*	*	-	-	2	2
		IR		C1							2	3
SBC dst, src	dst ← dst - src - C	r	r	32	*	*	*	*	1	*	2	3
		r	lr	33							2	4
		R	R	34							3	3
		R	IR	35							3	4
		R	IM	36							3	3
		IR	IM	37							3	4
SBCX dst, src	dst ← dst - src - C	ER	ER	38	*	*	*	*	1	*	4	3
		ER	IM	39							4	3
SCF	C ← 1			DF	1	-	-	-	-	-	1	2
SRA dst		R		D0	*	*	*	0	-	-	2	2
		IR		D1							2	3
SRL dst		R		1F C0	*	*	0	*	-	-	3	2
		IR		1F C1							3	3
SRP src	RP ← src		IM	01	-	-	-	-	-	-	2	2
STOP	STOP Mode			6F	-	-	-	-	-	-	1	2
SUB dst, src	dst ← dst - src	r	r	22	*	*	*	*	1	*	2	3
		r	lr	23							2	4
		R	R	24							3	3
		R	IR	25							3	4
		R	IM	26							3	3
		IR	IM	27							3	4
SUBX dst, src	dst ← dst - src	ER	ER	28	*	*	*	*	1	*	4	3
		ER	IM	29							4	3

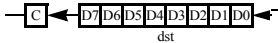
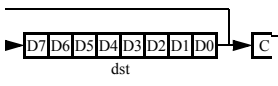

Table 133. eZ8 CPU Instruction Summary (Continued)

Assembly Mnemonic	Symbolic Operation	Address Mode		Opcode(s) (Hex)	Flags						Fetch Cycles	Instr. Cycles
		dst	src		C	Z	S	V	D	H		
SWAP dst	dst[7:4] ↔ dst[3:0]	R		F0	X	*	*	X	-	-	2	2
		IR		F1							2	3
TCM dst, src	(NOT dst) AND src	r	r	62	-	*	*	0	-	-	2	3
		r	lr	63							2	4
		R	R	64							3	3
		R	IR	65							3	4
		R	IM	66							3	3
		IR	IM	67							3	4
TCMX dst, src	(NOT dst) AND src	ER	ER	68	-	*	*	0	-	-	4	3
		ER	IM	69							4	3
TM dst, src	dst AND src	r	r	72	-	*	*	0	-	-	2	3
		r	lr	73							2	4
		R	R	74							3	3
		R	IR	75							3	4
		R	IM	76							3	3
		IR	IM	77							3	4
TMX dst, src	dst AND src	ER	ER	78	-	*	*	0	-	-	4	3
		ER	IM	79							4	3
TRAP Vector	SP ← SP - 2 @SP ← PC SP ← SP - 1 @SP ← FLAGS PC ← @Vector		Vector	F2	-	-	-	-	-	-	2	6
WDT				5F	-	-	-	-	-	-	1	2

Flags Register

The Flags Register contains the status information regarding the most recent arithmetic, logical, bit manipulation or rotate and shift operation. The Flags Register contains six bits of status information that are set or cleared by CPU operations. Four of the bits (C, V, Z and S) can be tested for use with conditional jump instructions. Two Flags (H and D) cannot be tested and are used for Binary-Coded Decimal (BCD) arithmetic.

The two remaining bits, User Flags (F1 and F2), are available as general-purpose status bits. User Flags are unaffected by arithmetic operations and must be set or cleared by instructions. The User Flags cannot be used with conditional Jumps. They are undefined at initial power-up and are unaffected by Reset. [Figure 58](#) displays the Flags and their bit positions in the Flags Register.

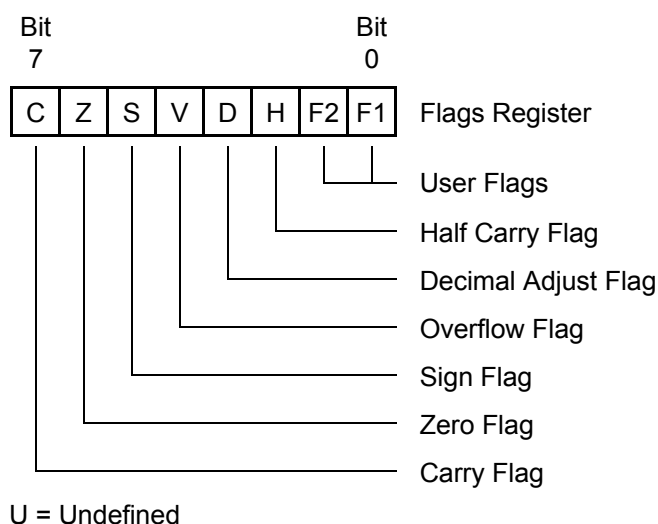

Figure 58. Flags Register

Interrupts, the Software Trap (TRAP) instruction, and Illegal Instruction Traps all write the value of the Flags Register to the stack. Executing an Interrupt Return (IRET) instruction restores the value saved on the stack into the Flags Register.



Opcode Maps

A description of the opcode map data and the abbreviations are provided in [Figure 59](#) and [Table 134](#) on page 262. [Figure 60](#) on page 263 and [Figure 61](#) on page 264 provide information on each of the eZ8[™] CPU instructions.

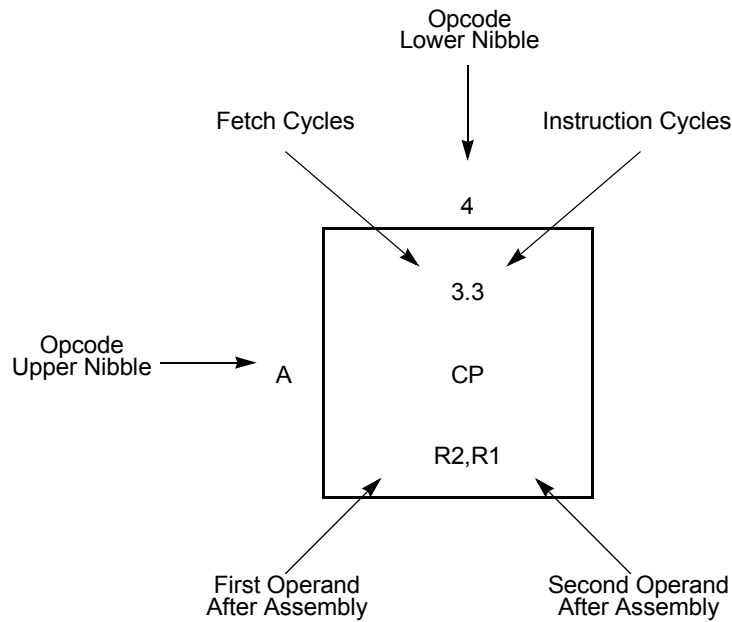

Figure 59. Opcode Map Cell Description

Table 134. Opcode Map Abbreviations

Abbreviation	Description	Abbreviation	Description
b	Bit position	IRR	Indirect Register Pair
cc	Condition code	p	Polarity (0 or 1)
X	8-bit signed index or displacement	r	4-bit Working Register
DA	Destination address	R	8-bit register
ER	Extended Addressing register	r1, R1, lr1, lrr1, IR1, rr1, RR1, IRR1, ER1	Destination address
IM	Immediate data value	r2, R2, lr2, lrr2, IR2, rr2, RR2, IRR2, ER2	Source address
lr	Indirect Working Register	RA	Relative
IR	Indirect register	rr	Working Register Pair
lrr	Indirect Working Register Pair	RR	Register Pair



		Lower Nibble (Hex)																
		0	1	2	3	4	5	6	7	8	9	A	B	C	D	E	F	
Upper Nibble (Hex)	0	1.2 BRK	2.2 SRP IM	2.3 ADD r1,r2	2.4 ADD r1,lr2	3.3 ADD R2,R1	3.4 ADD IR2,R1	3.3 ADD R1,IM	3.4 ADD IR1,IM	4.3 ADDX ER2,ER1	4.3 ADDX IM,ER1	2.3 DJNZ r1,X	2.2 JR cc,X	2.2 LD r1,IM	3.2 JP cc,DA	1.2 INC r1	1.2 NOP	
	1	2.2 RLC R1	2.3 RLC IR1	2.3 ADC r1,r2	2.4 ADC r1,lr2	3.3 ADC R2,R1	3.4 ADC IR2,R1	3.3 ADC R1,IM	3.4 ADC IR1,IM	4.3 ADCX ER2,ER1	4.3 ADCX IM,ER1							See 2nd Opcode Map
	2	2.2 INC R1	2.3 INC IR1	2.3 SUB r1,r2	2.4 SUB r1,lr2	3.3 SUB R2,R1	3.4 SUB IR2,R1	3.3 SUB R1,IM	3.4 SUB IR1,IM	4.3 SUBX ER2,ER1	4.3 SUBX IM,ER1							1.2 ATM
	3	2.2 DEC R1	2.3 DEC IR1	2.3 SBC r1,r2	2.4 SBC r1,lr2	3.3 SBC R2,R1	3.4 SBC IR2,R1	3.3 SBC R1,IM	3.4 SBC IR1,IM	4.3 SBCX ER2,ER1	4.3 SBCX IM,ER1							
	4	2.2 DA R1	2.3 DA IR1	2.3 OR r1,r2	2.4 OR r1,lr2	3.3 OR R2,R1	3.4 OR IR2,R1	3.3 OR R1,IM	3.4 OR IR1,IM	4.3 ORX ER2,ER1	4.3 ORX IM,ER1							
	5	2.2 POP R1	2.3 POP IR1	2.3 AND r1,r2	2.4 AND r1,lr2	3.3 AND R2,R1	3.4 AND IR2,R1	3.3 AND R1,IM	3.4 AND IR1,IM	4.3 ANDX ER2,ER1	4.3 ANDX IM,ER1							1.2 WDT
	6	2.2 COM R1	2.3 COM IR1	2.3 TCM r1,r2	2.4 TCM r1,lr2	3.3 TCM R2,R1	3.4 TCM IR2,R1	3.3 TCM R1,IM	3.4 TCM IR1,IM	4.3 TCMX ER2,ER1	4.3 TCMX IM,ER1							1.2 STOP
	7	2.2 PUSH R2	2.3 PUSH IR2	2.3 TM r1,r2	2.4 TM r1,lr2	3.3 TM R2,R1	3.4 TM IR2,R1	3.3 TM R1,IM	3.4 TM IR1,IM	4.3 TMX ER2,ER1	4.3 TMX IM,ER1							1.2 HALT
	8	2.5 DECW RR1	2.6 DECW IRR1	2.5 LDE r1,r2	2.9 LDEI lr1,lr2	3.2 LDX r1,ER2	3.3 LDX lr1,ER2	3.4 LDX IRR2,R1	3.5 LDX IRR2,IR1	3.4 LDX r1,rr2,X	3.4 LDX rr1,rr2,X							1.2 DI
	9	2.2 RL R1	2.3 RL IR1	2.5 LDE r2,lr1	2.9 LDEI lr2,lr1	3.2 LDX r2,ER1	3.3 LDX lr2,ER1	3.4 LDX R2,IRR1	3.5 LDX IRR2,IRR1	3.3 LEA r1,r2,X	3.5 LEA rr1,rr2,X							1.2 EI
	A	2.5 INCW RR1	2.6 INCW IRR1	2.3 CP r1,r2	2.4 CP r1,lr2	3.3 CP R2,R1	3.4 CP IR2,R1	3.3 CP R1,IM	3.4 CP IR1,IM	4.3 CPX ER2,ER1	4.3 CPX IM,ER1							1.4 RET
	B	2.2 CLR R1	2.3 CLR IR1	2.3 XOR r1,r2	2.4 XOR r1,lr2	3.3 XOR R2,R1	3.4 XOR IR2,R1	3.3 XOR R1,IM	3.4 XOR IR1,IM	4.3 XORX ER2,ER1	4.3 XORX IM,ER1							1.5 IRET
	C	2.2 RRC R1	2.3 RRC IR1	2.5 LDC r1,lr2	2.9 LDCI lr1,lr2	2.3 JP IRR1	2.9 LDC lr1,lr2		3.4 LD r1,r2,X	3.2 PUSHX ER2								1.2 RCF
	D	2.2 SRA R1	2.3 SRA IR1	2.5 LDC r2,lr1	2.9 LDCI lr2,lr1	2.6 CALL IRR1	2.2 BSWAP R1	3.3 CALL DA	3.4 LD r2,r1,X	3.2 POPX ER1								1.2 SCF
	E	2.2 RR R1	2.3 RR IR1	2.2 BIT p,b,r1	2.3 LD r1,lr2	3.2 LD R2,R1	3.3 LD IR2,R1	3.2 LD R1,IM	3.3 LD IR1,IM	4.2 LDX ER2,ER1	4.2 LDX IM,ER1							1.2 CCF
	F	2.2 SWAP R1	2.3 SWAP IR1	2.6 TRAP Vector	2.3 LD lr1,r2	2.8 MULT RR1	3.3 LD R2,IR1	3.3 BTJ p,b,r1,X	3.4 BTJ p,b,lr1,X									

Figure 60. First Opcode Map

		Lower Nibble (Hex)															
		0	1	2	3	4	5	6	7	8	9	A	B	C	D	E	F
Upper Nibble (Hex)	0																
	1																
	2																
	3																
	4																
	5																
	6																
	7		3.2 PUSH IM														
	8																
	9																
	A			3.3 CPC r1,r2	3.4 CPC r1,lr2	4.3 CPC R2,R1	4.4 CPC IR2,R1	4.3 CPC R1,IM	4.4 CPC IR1,IM	5.3 CPCX ER2,ER1	5.3 CPCX IM,ER1						
	B																
	C		3.2 SRL R1	3.3 SRL IR1													
	D																
	E										5.4 LDWX ER2,ER1						
	F																

Figure 61. Second Opcode Map after 1FH

Packaging

Figure 62 displays the 40-pin Plastic Dual-inline Package (PDIP) available for the Z8X1601, Z8X2401, Z8X3201, Z8X4801, and Z8X6401 devices.

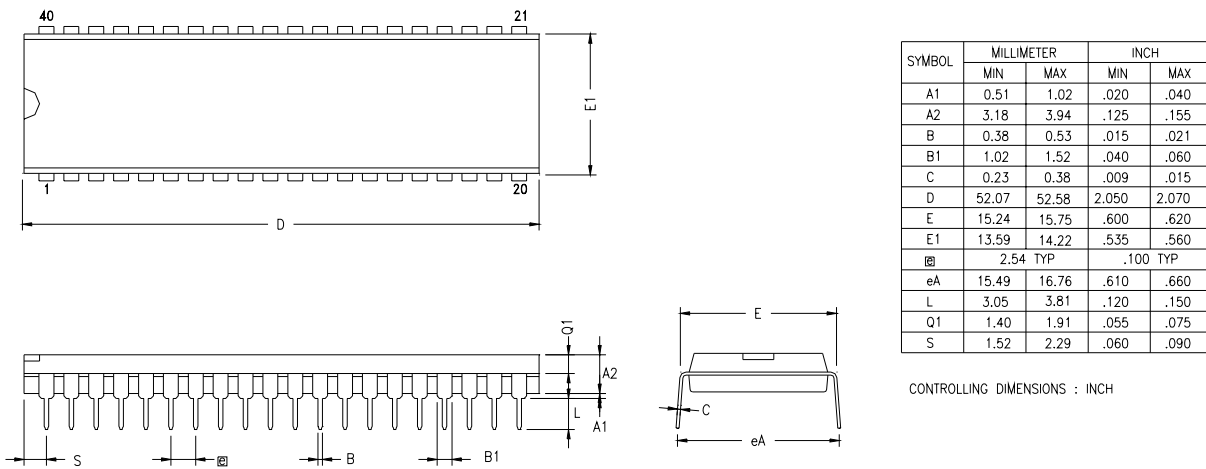

Figure 62. 40-Lead Plastic Dual-Inline Package (PDIP)

Figure 63 displays the 44-pin Low Profile Quad Flat Package (LQFP) available for the Z8X1621, Z8X2421, Z8X3221, Z8X4821, and Z8X6421 devices.

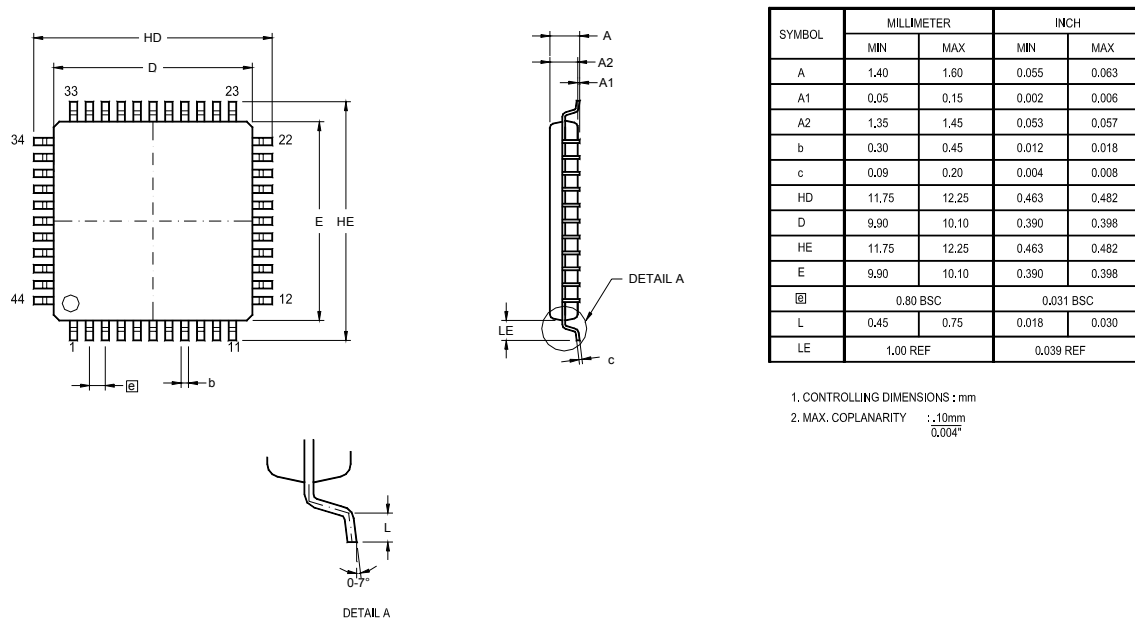

Figure 63. 44-Lead Low-Profile Quad Flat Package (LQFP)

Figure 64 displays the 44-pin Plastic Lead Chip Carrier (PLCC) package available for the Z8X1621, Z8X2421, Z8X3221, Z8X4821, and Z8X6421 devices.

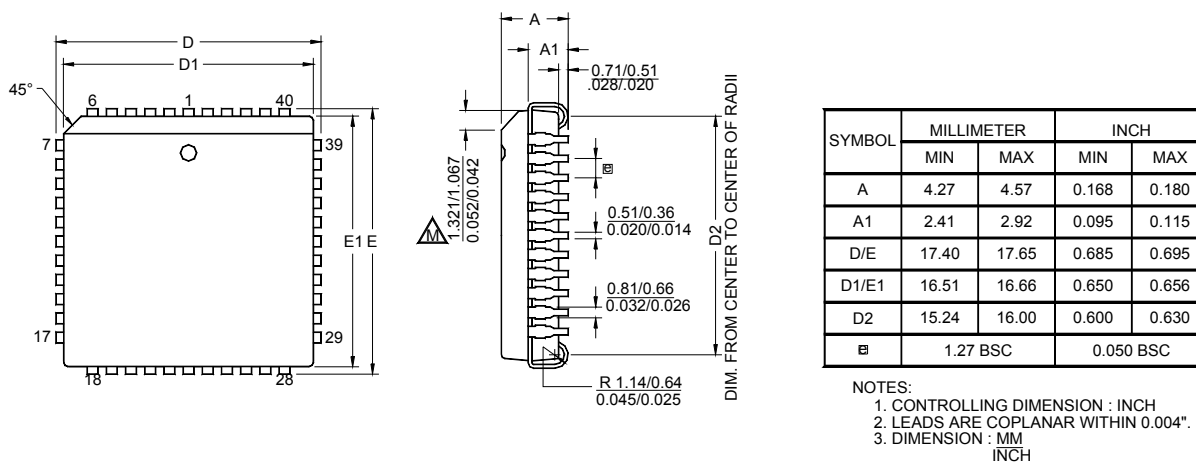

Figure 64. 44-Lead Plastic Lead Chip Carrier Package (PLCC)

Figure 64 displays the 64-pin Low-Profile Quad Flat Package (LQFP) available for the Z8X1622, Z8X2422, Z8X3222, Z8X4822, and Z8X6422 devices.

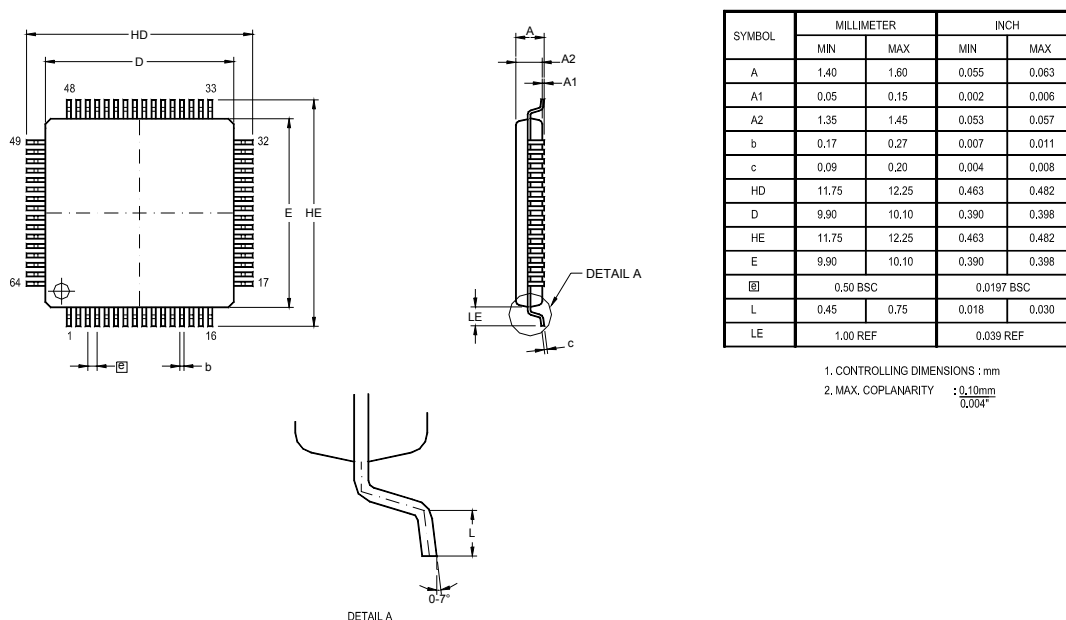

Figure 65. 64-Lead Low-Profile Quad Flat Package (LQFP)

Figure 66 displays the 68-pin Plastic Lead Chip Carrier (PLCC) package available for the Z8X1622, Z8X2422, Z8X3222, Z8X4822, and Z8X6422 devices.

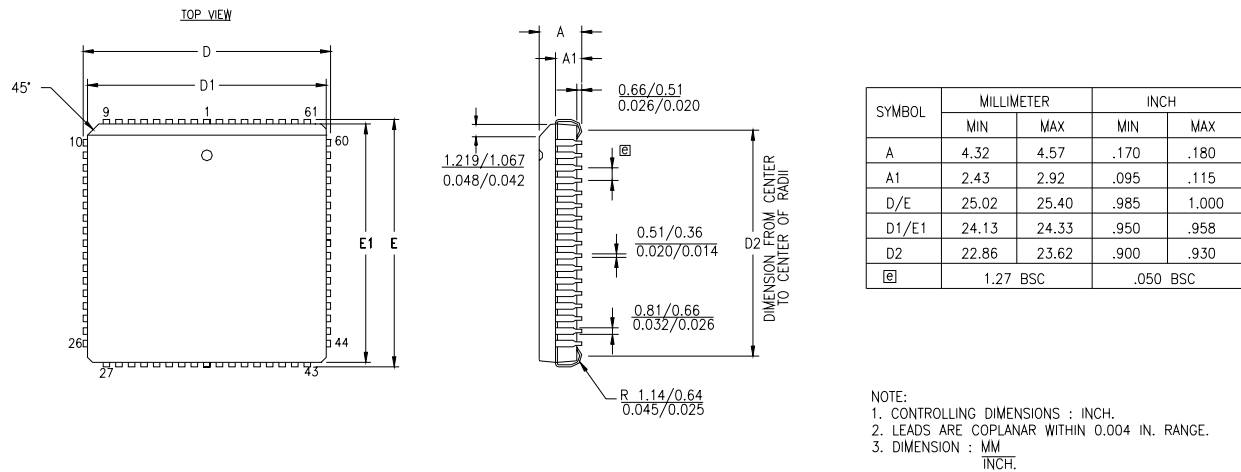

Figure 66. 68-Lead Plastic Lead Chip Carrier Package (PLCC)

Figure 67 displays the 80-pin Quad Flat Package (QFP) available for the Z8X4823 and Z8X6423 devices.

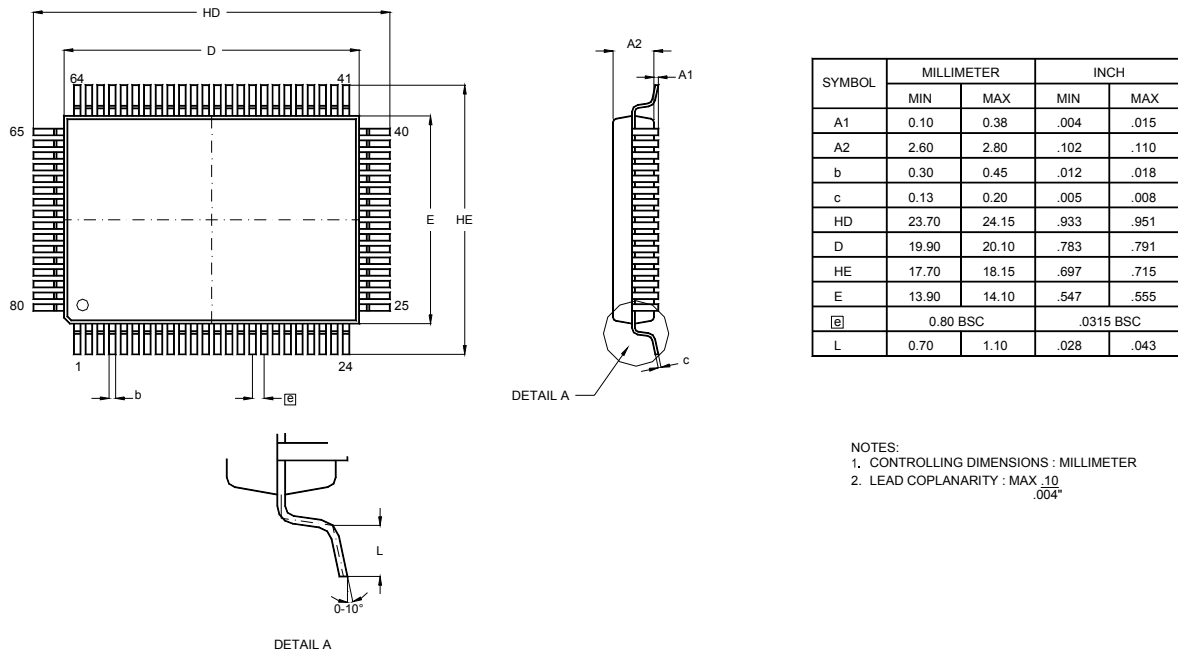

Figure 67. 80-Lead Quad-Flat Package (QFP)

Ordering Information

Part Number	Flash	RAM	I/O Lines	Interrupts	16-Bit Timers w/PWM	10-Bit A/D Channels	I ² C	SPI	UARTs with IrDA	Description
Z8F642x with 64 KB Flash, 10-Bit Analog-to-Digital Converter										
Standard Temperature: 0 °C to 70 °C										
Z8F6421PM020SC	64 KB	4 KB	29	23	3	8	1	1	2	PDIP 40-pin package
Z8F6421AN020SC	64 KB	4 KB	31	23	3	8	1	1	2	LQFP 44-pin package
Z8F6421VN020SC	64 KB	4 KB	31	23	3	8	1	1	2	PLCC 44-pin package
Z8F6422AR020SC	64 KB	4 KB	46	24	4	12	1	1	2	LQFP 64-pin package
Z8F6422VS020SC	64 KB	4 KB	46	24	4	12	1	1	2	PLCC 68-pin package
Z8F6423FT020SC	64 KB	4 KB	60	24	4	12	1	1	2	QFP 80-pin package
Extended Temperature: -40 °C to +105 °C										
Z8F6421PM020EC	64 KB	4 KB	29	23	3	8	1	1	2	PDIP 40-pin package
Z8F6421AN020EC	64 KB	4 KB	31	23	3	8	1	1	2	LQFP 44-pin package
Z8F6421VN020EC	64 KB	4 KB	31	23	3	8	1	1	2	PLCC 44-pin package
Z8F6422AR020EC	64 KB	4 KB	46	24	4	12	1	1	2	LQFP 64-pin package
Z8F6422VS020EC	64 KB	4 KB	46	24	4	12	1	1	2	PLCC 68-pin package
Z8F6423FT020EC	64 KB	4 KB	60	24	4	12	1	1	2	QFP 80-pin package
Automotive/Industrial Temperature: -40 °C to +125 °C										
Z8F6421PM020AC	64 KB	4 KB	29	23	3	8	1	1	2	PDIP 40-pin package
Z8F6421AN020AC	64 KB	4 KB	31	23	3	8	1	1	2	LQFP 44-pin package
Z8F6421VN020AC	64 KB	4 KB	31	23	3	8	1	1	2	PLCC 44-pin package
Z8F6422AR020AC	64 KB	4 KB	46	24	4	12	1	1	2	LQFP 64-pin package
Z8F6422VS020AC	64 KB	4 KB	46	24	4	12	1	1	2	PLCC 68-pin package
Z8F6423FT020AC	64 KB	4 KB	60	24	4	12	1	1	2	QFP 80-pin package



Part Number	Flash	RAM	I/O Lines	Interrupts	16-Bit Timers w/PWM	10-Bit A/D Channels	I ² C	SPI	UARTs with IrDA	Description
Z8F482x with 48 KB Flash, 10-Bit Analog-to-Digital Converter										
Standard Temperature: 0 °C to 70 °C										
Z8F4821PM020SC	48 KB	4 KB	29	23	3	8	1	1	2	PDIP 40-pin package
Z8F4821AN020SC	48 KB	4 KB	31	23	3	8	1	1	2	LQFP 44-pin package
Z8F4821VN020SC	48 KB	4 KB	31	23	3	8	1	1	2	PLCC 44-pin package
Z8F4822AR020SC	48 KB	4 KB	46	24	4	12	1	1	2	LQFP 64-pin package
Z8F4822VS020SC	48 KB	4 KB	46	24	4	12	1	1	2	PLCC 68-pin package
Z8F4823FT020SC	48 KB	4 KB	60	24	4	12	1	1	2	QFP 80-pin package
Extended Temperature: -40 °C to +105 °C										
Z8F4821PM020EC	48 KB	4 KB	29	23	3	8	1	1	2	PDIP 40-pin package
Z8F4821AN020EC	48 KB	4 KB	31	23	3	8	1	1	2	LQFP 44-pin package
Z8F4821VN020EC	48 KB	4 KB	31	23	3	8	1	1	2	PLCC 44-pin package
Z8F4822AR020EC	48 KB	4 KB	46	24	4	12	1	1	2	LQFP 64-pin package
Z8F4822VS020EC	48 KB	4 KB	46	24	4	12	1	1	2	PLCC 68-pin package
Z8F4823FT020EC	48 KB	4 KB	60	24	4	12	1	1	2	QFP 80-pin package
Automotive/Industrial Temperature: -40 °C to +125 °C										
Z8F4821PM020AC	48 KB	4 KB	29	23	3	8	1	1	2	PDIP 40-pin package
Z8F4821AN020AC	48 KB	4 KB	31	23	3	8	1	1	2	LQFP 44-pin package
Z8F4821VN020AC	48 KB	4 KB	31	23	3	8	1	1	2	PLCC 44-pin package
Z8F4822AR020AC	48 KB	4 KB	46	24	4	12	1	1	2	LQFP 64-pin package
Z8F4822VS020AC	48 KB	4 KB	46	24	4	12	1	1	2	PLCC 68-pin package
Z8F4823FT020AC	48 KB	4 KB	60	24	4	12	1	1	2	QFP 80-pin package



Part Number	Flash	RAM	I/O Lines	Interrupts	16-Bit Timers w/PWM	10-Bit A/D Channels	I ² C	SPI	UARTs with IrDA	Description
Z8F322x with 32 KB Flash, 10-Bit Analog-to-Digital Converter										
Standard Temperature: 0 °C to 70 °C										
Z8F3221PM020SC	32 KB	2 KB	29	23	3	8	1	1	2	PDIP 40-pin package
Z8F3221AN020SC	32 KB	2 KB	31	23	3	8	1	1	2	LQFP 44-pin package
Z8F3221VN020SC	32 KB	2 KB	31	23	3	8	1	1	2	PLCC 44-pin package
Z8F3222AR020SC	32 KB	2 KB	46	24	4	12	1	1	2	LQFP 64-pin package
Z8F3222VS020SC	32 KB	2 KB	46	24	4	12	1	1	2	PLCC 68-pin package
Extended Temperature: –40 °C to 105 °C										
Z8F3221PM020EC	32 KB	2 KB	29	23	3	8	1	1	2	PDIP 40-pin package
Z8F3221AN020EC	32 KB	2 KB	31	23	3	8	1	1	2	LQFP 44-pin package
Z8F3221VN020EC	32 KB	2 KB	31	23	3	8	1	1	2	PLCC 44-pin package
Z8F3222AR020EC	32 KB	2 KB	46	24	4	12	1	1	2	LQFP 64-pin package
Z8F3222VS020EC	32 KB	2 KB	46	24	4	12	1	1	2	PLCC 68-pin package
Automotive/Industrial Temperature: –40 °C to 125°C										
Z8F3221PM020AC	32 KB	2 KB	29	23	3	8	1	1	2	PDIP 40-pin package
Z8F3221AN020AC	32 KB	2 KB	31	23	3	8	1	1	2	LQFP 44-pin package
Z8F3221VN020AC	32 KB	2 KB	31	23	3	8	1	1	2	PLCC 44-pin package
Z8F3222AR020AC	32 KB	2 KB	46	24	4	12	1	1	2	LQFP 64-pin package
Z8F3222VS020AC	32 KB	2 KB	46	24	4	12	1	1	2	PLCC 68-pin package



Part Number	Flash	RAM	I/O Lines	Interrupts	16-Bit Timers w/PWM	10-Bit A/D Channels	I ² C	SPI	UARTs with IrDA	Description
Z8F242x with 24 KB Flash, 10-Bit Analog-to-Digital Converter										
Standard Temperature: 0 °C to 70 °C										
Z8F2421PM020SC	24 KB	2 KB	29	23	3	8	1	1	2	PDIP 40-pin package
Z8F2421AN020SC	24 KB	2 KB	31	23	3	8	1	1	2	LQFP 44-pin package
Z8F2421VN020SC	24 KB	2 KB	31	23	3	8	1	1	2	PLCC 44-pin package
Z8F2422AR020SC	24 KB	2 KB	46	24	4	12	1	1	2	LQFP 64-pin package
Z8F2422VS020SC	24 KB	2 KB	46	24	4	12	1	1	2	PLCC 68-pin package
Extended Temperature: –40 °C to 105 °C										
Z8F2421PM020EC	24 KB	2 KB	29	23	3	8	1	1	2	PDIP 40-pin package
Z8F2421AN020EC	24 KB	2 KB	31	23	3	8	1	1	2	LQFP 44-pin package
Z8F2421VN020EC	24 KB	2 KB	31	23	3	8	1	1	2	PLCC 44-pin package
Z8F2422AR020EC	24 KB	2 KB	46	24	4	12	1	1	2	LQFP 64-pin package
Z8F2422VS020EC	24 KB	2 KB	46	24	4	12	1	1	2	PLCC 68-pin package
Automotive/Industrial Temperature: –40 °C to 125 °C										
Z8F2421PM020AC	24 KB	2 KB	29	23	3	8	1	1	2	PDIP 40-pin package
Z8F2421AN020AC	24 KB	2 KB	31	23	3	8	1	1	2	LQFP 44-pin package
Z8F2421VN020AC	24 KB	2 KB	31	23	3	8	1	1	2	PLCC 44-pin package
Z8F2422AR020AC	24 KB	2 KB	46	24	4	12	1	1	2	LQFP 64-pin package
Z8F2422VS020AC	24 KB	2 KB	46	24	4	12	1	1	2	PLCC 68-pin package



Part Number	Flash	RAM	I/O Lines	Interrupts	16-Bit Timers w/PWM	10-Bit A/D Channels	I ² C	SPI	UARTs with IrDA	Description
Z8F162x with 16 KB Flash, 10-Bit Analog-to-Digital Converter										
Standard Temperature: 0 °C to 70 °C										
Z8F1621PM020SC	16 KB	2 KB	29	23	3	8	1	1	2	PDIP 40-pin package
Z8F1621AN020SC	16 KB	2 KB	31	23	3	8	1	1	2	LQFP 44-pin package
Z8F1621VN020SC	16 KB	2 KB	31	23	3	8	1	1	2	PLCC 44-pin package
Z8F1622AR020SC	16 KB	2 KB	46	24	4	12	1	1	2	LQFP 64-pin package
Z8F1622VS020SC	16 KB	2 KB	46	24	4	12	1	1	2	PLCC 68-pin package
Extended Temperature: -40 °C to +105 °C										
Z8F1621PM020EC	16 KB	2 KB	29	23	3	8	1	1	2	PDIP 40-pin package
Z8F1621AN020EC	16 KB	2 KB	31	23	3	8	1	1	2	LQFP 44-pin package
Z8F1621VN020EC	16 KB	2 KB	31	23	3	8	1	1	2	PLCC 44-pin package
Z8F1622AR020EC	16 KB	2 KB	46	24	4	12	1	1	2	LQFP 64-pin package
Z8F1622VS020EC	16 KB	2 KB	46	24	4	12	1	1	2	PLCC 68-pin package
Automotive/Industrial Temperature: -40 °C to +125 °C										
Z8F1621PM020AC	16 KB	2 KB	29	23	3	8	1	1	2	PDIP 40-pin package
Z8F1621AN020AC	16 KB	2 KB	31	23	3	8	1	1	2	LQFP 44-pin package
Z8F1621VN020AC	16 KB	2 KB	31	23	3	8	1	1	2	PLCC 44-pin package
Z8F1622AR020AC	16 KB	2 KB	46	24	4	12	1	1	2	LQFP 64-pin package
Z8F1622VS020AC	16 KB	2 KB	46	24	4	12	1	1	2	PLCC 68-pin package
Z8F64200100KITG										Development Kit
ZUSBSC00100ZACG										USB Smart Cable Accessory Kit
ZUSBOPTSC01ZACG										Opto-Isolated USB Smart Cable Accessory Kit

Note: Replace C with G for lead-free packaging.

For technical and customer support, hardware and software development tools, refer to the Zilog[®] website at www.zilog.com. The latest released version of ZDS can be downloaded from this website.

Part Number Suffix Designations

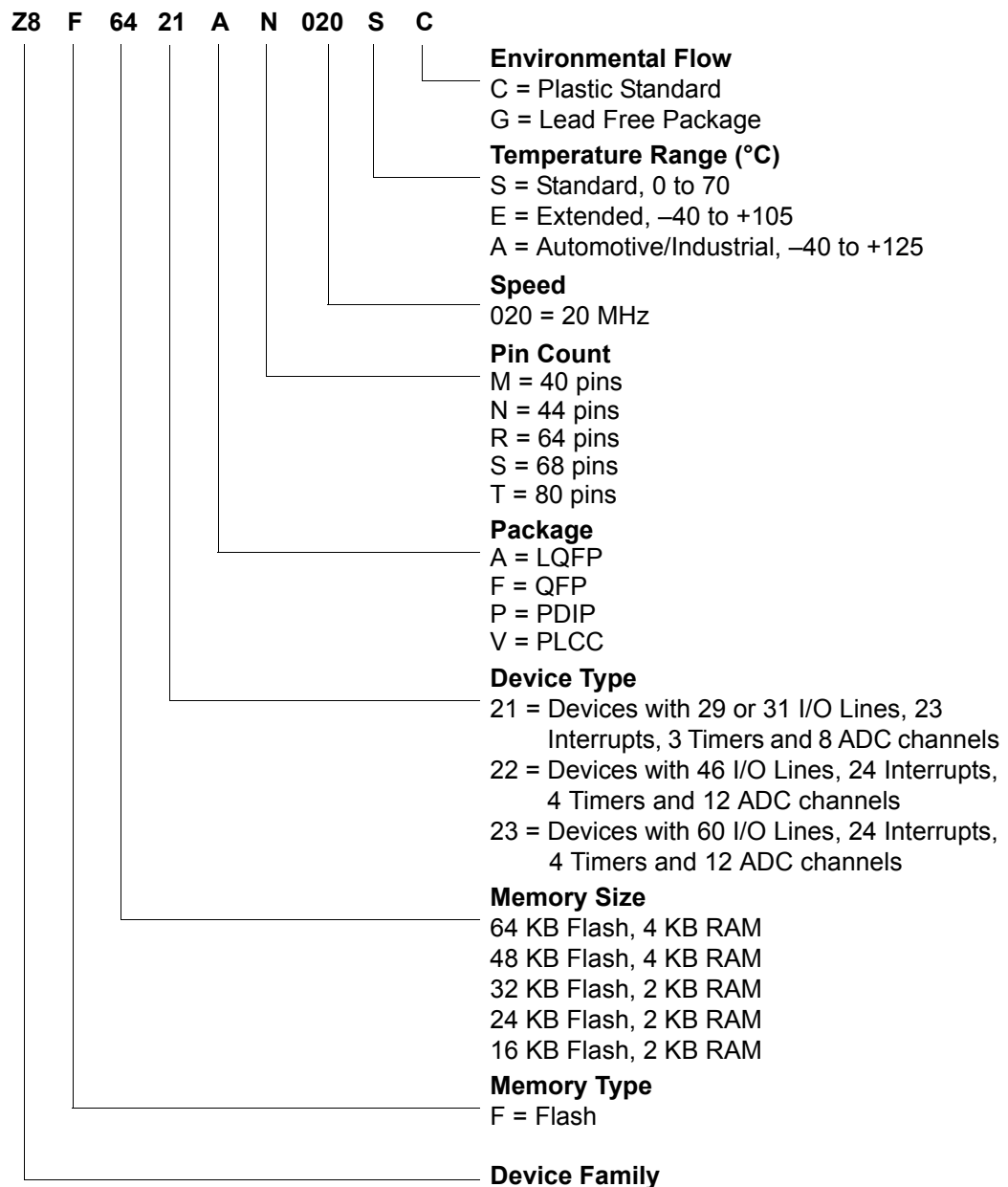



Example: Part number Z8F6421AN020SC is an 8-bit microcontroller product in an LQFP package, using 44 pins, operating with a maximum 20 MHz external clock frequency over a 0 °C to +70 °C temperature range and built using the Plastic-Standard environmental flow.

Index

Symbols

244
% 244
@ 244

Numerics

10-bit ADC 4
40-lead plastic dual-inline package 265
44-lead low-profile quad flat package 266
44-lead plastic lead chip carrier package 267
64-lead low-profile quad flat package 267
68-lead plastic lead chip carrier package 268
80-lead quad flat package 269

A

absolute maximum ratings 215
AC characteristics 231
ADC 246
 architecture 175
 automatic power-down 176
 block diagram 176
 continuous conversion 177
 control register 179
 control register definitions 179
 data high byte register 180
 data low bits register 180
 DMA control 178
 electrical characteristics and timing 229
 operation 176
 single-shot conversion 177
ADCCTL register 179
ADCDH register 180
ADC DL register 180
ADCX 246
ADD 246
add - extended addressing 246
add with carry 246
add with carry - extended addressing 246

additional symbols 244
address space 19
ADDX 246
analog signals 15
analog-to-digital converter (ADC) 175
AND 248
ANDX 248
arithmetic instructions 246
assembly language programming 241
assembly language syntax 242

B

B 244
b 243
baud rate generator, UART 113
BCLR 246
binary number suffix 244
BIT 246
bit 243
 clear 246
 manipulation instructions 246
 set 246
 set or clear 246
 swap 247
 test and jump 249
 test and jump if non-zero 249
 test and jump if zero 249
bit jump and test if non-zero 249
bit swap 249
block diagram 3
block transfer instructions 247
BRK 249
BSET 246
BSWAP 247, 249
BTJ 249
BTJNZ 249
BTJZ 249

C

CALL procedure 249
capture mode 95
capture/compare mode 95

cc 243
CCF 247
characteristics, electrical 215
clear 248
clock phase (SPI) 132
CLR 248
COM 248
compare 95
compare - extended addressing 246
compare mode 95
compare with carry 246
compare with carry - extended addressing 246
complement 248
complement carry flag 247
condition code 243
continuous conversion (ADC) 177
continuous mode 94
control register definition, UART 114
control register, I2C 158
counter modes 94
CP 246
CPC 246
CPCX 246
CPU and peripheral overview 3
CPU control instructions 247
CPX 246
Customer Feedback Form 287
customer feedback form 276

D

DA 243, 246
data register, I2C 156
DC characteristics 217
debugger, on-chip 199
DEC 246
decimal adjust 246
decrement 246
decrement and jump non-zero 249
decrement word 246
DECW 246
destination operand 244
device, port availability 57
DI 247

direct address 243
direct memory access controller 165
disable interrupts 247
DJNZ 249
DMA
 address high nibble register 169
 configuring DMA0-1 data transfer 166
 configuring for DMA_ADC data transfer 167
 control of ADC 178
 control register 167
 control register definitions 167
 controller 5
 DMA_ADC address register 171
 DMA_ADC control register 172
 DMA_ADC operation 166
 end address low byte register 170
 I/O address register 168
 operation 165
 start/current address low byte register 170
 status register 173
DMAA_STAT register 173
DMAACTL register 172
DMAxCTL register 167
DMAxEND register 170
DMAxH register 169
DMAxI/O address (DMAxIO) 169
DMAxIO register 169
DMAxSTART register 170
dst 244

E

EI 247
electrical characteristics 215
 ADC 229
 flash memory and timing 228
 GPIO input data sample timing 232
 watch-dog timer 228
enable interrupt 247
ER 243
extended addressing register 243
external pin reset 51
external RC oscillator 227
eZ8 CPU features 3

eZ8 CPU instruction classes 245
eZ8 CPU instruction notation 242
eZ8 CPU instruction set 241
eZ8 CPU instruction summary 250

F

FCTL register 190
features, Z8 Encore! 1
first opcode map 263
FLAGS 244
flags register 244
flash
 controller 4
 option bit address space 195
 option bit configuration - reset 195
 program memory address 0001H 197
flash memory
 arrangement 184
 byte programming 187
 code protection 186
 configurations 183
 control register definitions 190
 controller bypass 189
 electrical characteristics and timing 228
 flash control register 190
 flash status register 190
 frequency high and low byte registers 192
 mass erase 189
 operation 185
 operation timing 186
 page erase 188
 page select register 191
FPS register 191
FSTAT register 190

G

gated mode 95
general-purpose I/O 57
GPIO 4, 57
 alternate functions 59
 architecture 58
 control register definitions 61

input data sample timing 232
interrupts 60
port A-H address registers 61
port A-H alternate function sub-registers 63
port A-H control registers 62
port A-H data direction sub-registers 63
port A-H high drive enable sub-registers 64
port A-H input data registers 66
port A-H output control sub-registers 64
port A-H output data registers 66
port A-H Stop Mode Recovery sub-registers 65
port availability by device 57
port input timing 232
port output timing 233

H

H 244
HALT 247
halt mode 56, 247
hexadecimal number prefix/suffix 244

I

I2C 4
 10-bit address read transaction 154
 10-bit address transaction 151
 10-bit addressed slave data transfer format 151
 10-bit receive data format 154
 7-bit address transaction 149
 7-bit address, reading a transaction 153
 7-bit addressed slave data transfer format 148, 149, 150
 7-bit receive data transfer format 153
 baud high and low byte registers 160, 161, 163
 C status register 157
 control register definitions 156
 controller 143
 controller signals 14
 interrupts 145
 operation 144
 SDA and SCL signals 145
 stop and start conditions 147
I2CBRH register 160, 161, 163

I2CBRL register 161
I2CCTL register 158
I2CDATA register 157
I2CSTAT register 157
IM 243
immediate data 243
immediate operand prefix 244
INC 246
increment 246
increment word 246
INCW 246
indexed 243
indirect address prefix 244
indirect register 243
indirect register pair 243
indirect working register 243
indirect working register pair 243
infrared encoder/decoder (IrDA) 125
instruction set, ez8 CPU 241
instructions
 ADC 246
 ADCX 246
 ADD 246
 ADDX 246
 AND 248
 ANDX 248
 arithmetic 246
 BCLR 246
 BIT 246
 bit manipulation 246
 block transfer 247
 BRK 249
 BSET 246
 BSWAP 247, 249
 BTJ 249
 BTJNZ 249
 BTJZ 249
 CALL 249
 CCF 247
 CLR 248
 COM 248
 CP 246
 CPC 246
 CPCX 246
 CPU control 247
 CPX 246
 DA 246
 DEC 246
 DECW 246
 DI 247
 DJNZ 249
 EI 247
 HALT 247
 INC 246
 INCW 246
 IRET 249
 JP 249
 LD 248
 LDC 248
 LDCI 247, 248
 LDE 248
 LDEI 247
 LDX 248
 LEA 248
 load 248
 logical 248
 MULT 246
 NOP 247
 OR 248
 ORX 248
 POP 248
 POPX 248
 program control 249
 PUSH 248
 PUSHX 248
 RCF 247
 RET 249
 RL 249
 RLC 249
 rotate and shift 249
 RR 249
 RRC 249
 SBC 246
 SCF 247
 SRA 249
 SRL 250
 SRP 247
 STOP 248

- SUB 246
- SUBX 246
- SWAP 250
- TCM 247
- TCMX 247
- TM 247
- TMX 247
- TRAP 249
- watch-dog timer refresh 248
- XOR 249
- XORX 249
- instructions, eZ8 classes of 245
- interrupt control register 79
- interrupt controller 5, 67
 - architecture 67
 - interrupt assertion types 70
 - interrupt vectors and priority 70
 - operation 69
 - register definitions 71
 - software interrupt assertion 70
- interrupt edge select register 78
- interrupt port select register 78
- interrupt request 0 register 71
- interrupt request 1 register 72
- interrupt request 2 register 73
- interrupt return 249
- interrupt vector listing 67
- interrupts
 - not acknowledge 145
 - receive 145
 - SPI 135
 - transmit 145
 - UART 111
- introduction 1
- IR 243
- Ir 243
- IrDA
 - architecture 125
 - block diagram 125
 - control register definitions 128
 - operation 126
 - receiving data 127
 - transmitting data 126
- IRET 249
- IRQ0 enable high and low bit registers 74
- IRQ1 enable high and low bit registers 75
- IRQ2 enable high and low bit registers 76
- IRR 243
- Irr 243
- J**
 - JP 249
 - jump, conditional, relative, and relative conditional 249
- L**
 - LD 248
 - LDC 248
 - LDCI 247, 248
 - LDE 248
 - LDEI 247, 248
 - LDX 248
 - LEA 248
 - load 248
 - load constant 247
 - load constant to/from program memory 248
 - load constant with auto-increment addresses 248
 - load effective address 248
 - load external data 248
 - load external data to/from data memory and auto-increment addresses 247
 - load external to/from data memory and auto-increment addresses 248
 - load instructions 248
 - load using extended addressing 248
 - logical AND 248
 - logical AND/extended addressing 248
 - logical exclusive OR 249
 - logical exclusive OR/extended addressing 249
 - logical instructions 248
 - logical OR 248
 - logical OR/extended addressing 248
 - low power modes 55
 - LQFP
 - 44 lead 266
 - 64 lead 267

M

- master interrupt enable 69
- master-in, slave-out and-in 131
- memory
 - program 20
- MISO 131
- mode
 - capture 95
 - capture/compare 95
 - continuous 94
 - counter 94
 - gated 95
 - one-shot 94
 - PWM 94
- modes 95
- MULT 246
- multiply 246
- multiprocessor mode, UART 109

N

- NOP (no operation) 247
- not acknowledge interrupt 145
- notation
 - b 243
 - cc 243
 - DA 243
 - ER 243
 - IM 243
 - IR 243
 - Ir 243
 - IRR 243
 - Irr 243
 - p 243
 - R 243
 - r 243
 - RA 243
 - RR 243
 - rr 243
 - vector 243
 - X 243
- notational shorthand 243

O

- OCD
 - architecture 199
 - auto-baud detector/generator 202
 - baud rate limits 202
 - block diagram 199
 - breakpoints 203
 - commands 204
 - control register 209
 - data format 202
 - DBG pin to RS-232 Interface 200
 - debug mode 201
 - debugger break 249
 - interface 200
 - serial errors 203
 - status register 210
 - timing 234
- OCD commands
 - execute instruction (12H) 208
 - read data memory (0DH) 207
 - read OCD control register (05H) 206
 - read OCD revision (00H) 205
 - read OCD status register (02H) 205
 - read program counter (07H) 206
 - read program memory (0BH) 207
 - read program memory CRC (0EH) 208
 - read register (09H) 206
 - step instruction (10H) 208
 - stuff instruction (11H) 208
 - write data memory (0CH) 207
 - write OCD control register (04H) 206
 - write program counter (06H) 206
 - write program memory (0AH) 207
 - write register (08H) 206
- on-chip debugger 5
- on-chip debugger (OCD) 199
- on-chip debugger signals 16
- on-chip oscillator 211
- one-shot mode 94
- opcode map
 - abbreviations 262
 - cell description 261
 - first 263
 - second after 1FH 264

Operational Description 103
OR 248
ordering information 270
ORX 248
oscillator signals 15

P

p 243
packaging
 LQFP
 44 lead 266
 64 lead 267
 PDIP 265
 PLCC
 44 lead 267
 68 lead 268
 QFP 269
part number description 275
part selection guide 2
PC 244
PDIP 265
peripheral AC and DC electrical characteristics 226
PHASE=0 timing (SPI) 133
PHASE=1 timing (SPI) 134
pin characteristics 16
PLCC
 44 lead 267
 68-lead 268
polarity 243
POP 248
pop using extended addressing 248
POPX 248
port availability, device 57
port input timing (GPIO) 232
port output timing, GPIO 233
power supply signals 16
power-down, automatic (ADC) 176
power-on and voltage brown-out 226
power-on reset (POR) 49
program control instructions 249
program counter 244
program memory 20
PUSH 248

push using extended addressing 248
PUSHX 248
PWM mode 94
PxADDR register 61
PxCTL register 62

Q

QFP 269

R

R 243
r 243
RA
 register address 243
RCF 247
receive
 10-bit data format (I2C) 154
 7-bit data transfer format (I2C) 153
 IrDA data 127
receive interrupt 145
receiving UART data-interrupt-driven method 108
receiving UART data-pollled method 107
register 140, 169, 243
 ADC control (ADCCTL) 179
 ADC data high byte (ADCDH) 180
 ADC data low bits (ADC DL) 180
 baud low and high byte (I2C) 160, 161, 163
 baud rate high and low byte (SPI) 142
 control (SPI) 137
 control, I2C 158
 data, SPI 137
 DMA status (DMAA_STAT) 173
 DMA_ADC address 171
 DMA_ADC control DMAACTL) 172
 DMAx address high nibble (DMAxH) 169
 DMAx control (DMAxCTL) 167
 DMAx end/address low byte (DMAxEND) 170
 DMAx start/current address low byte register (DMAxSTART) 170
 flash control (FCTL) 190
 flash high and low byte (FFREQH and FRE-EQL) 192

- flash page select (FPS) 191
- flash status (FSTAT) 190
- GPIO port A-H address (PxADDR) 61
- GPIO port A-H alternate function sub-registers 63
- GPIO port A-H control address (PxCTL) 62
- GPIO port A-H data direction sub-registers 63
- I2C baud rate high (I2CBRH) 160, 161, 163
- I2C control (I2CCTL) 158
- I2C data (I2CDATA) 157
- I2C status 157
- I2C status (I2CSTAT) 157
- I2Cbaud rate low (I2CBRL) 161
- mode, SPI 140
- OCD control 209
- OCD status 210
- SPI baud rate high byte (SPIBRH) 142
- SPI baud rate low byte (SPIBRL) 142
- SPI control (SPICTL) 138
- SPI data (SPIDATA) 137
- SPI status (SPISTAT) 139
- status, I2C 157
- status, SPI 139
- UARTx baud rate high byte (UxBRH) 121
- UARTx baud rate low byte (UxBRL) 121
- UARTx Control 0 (UxCTL0) 117, 120
- UARTx control 1 (UxCTL1) 118
- UARTx receive data (UxRXD) 115
- UARTx status 0 (UxSTAT0) 115
- UARTx status 1 (UxSTAT1) 117
- UARTx transmit data (UxTXD) 114
- watch-dog timer control (WDTCTL) 100
- watch-dog timer reload high byte (WDTH) 102
- watch-dog timer reload low byte (WDTL) 102
- watch-dog timer reload upper byte (WDTU) 102
- register file 19
- register file address map 23
- register pair 243
- register pointer 244
- reset
 - and STOP mode characteristics 48
 - carry flag 247
 - controller 5
 - sources 48
- RET 249
- return 249
- RL 249
- RLC 249
- rotate and shift instructions 249
- rotate left 249
- rotate left through carry 249
- rotate right 249
- rotate right through carry 249
- RP 244
- RR 243, 249
- rr 243
- RRC 249
- S**
- SBC 246
- SCF 247
- SDA and SCL (IrDA) signals 145
- second opcode map after 1FH 264
- serial clock 131
- serial peripheral interface (SPI) 129
- set carry flag 247
- set register pointer 247
- shift right arithmetic 249
- shift right logical 250
- signal descriptions 14
- single-shot conversion (ADC) 177
- SIO 5
- slave data transfer formats (I2C) 151
- slave select 132
- software trap 249
- source operand 244
- SP 244
- SPI
 - architecture 129
 - baud rate generator 136
 - baud rate high and low byte register 142
 - clock phase 132
 - configured as slave 130
 - control register 137
 - control register definitions 137
 - data register 137

- error detection 135
- interrupts 135
- mode fault error 135
- mode register 140
- multi-master operation 134
- operation 130
- overrun error 135
- signals 131
- single master, multiple slave system 130
- single master, single slave system 129
- status register 139
- timing, PHASE = 0 133
- timing, PHASE=1 134
- SPI controller signals 14
- SPI mode (SPIMODE) 140
- SPIBRH register 142
- SPIBRL register 142
- SPICTL register 138
- SPIDATA register 137
- SPIMODE register 140
- SPISTAT register 139
- SRA 249
- src 244
- SRL 250
- SRP 247
- stack pointer 244
- status register, I2C 157
- STOP 248
- STOP mode 55, 248
- STOP mode recovery
 - sources 52
 - using a GPIO port pin transition 53
 - using watchdog timer time-out 52
- SUB 246
- subtract 246
- subtract - extended addressing 246
- subtract with carry 246
- subtract with carry - extended addressing 246
- SUBX 246
- SWAP 250
- swap nibbles 250
- symbols, additional 244
- system and core resets 48

T

- TCM 247
- TCMX 247
- Technical Support 287
- test complement under mask 247
- test complement under mask - extended addressing 247
- test under mask 247
- test under mask - extended addressing 247
- timer signals 15
- timers 5, 81
 - architecture 81
 - block diagram 82
 - capture mode 86, 95
 - capture/compare mode 89, 95
 - compare mode 87, 95
 - continuous mode 83, 94
 - counter mode 84
 - counter modes 94
 - gated mode 88, 95
 - one-shot mode 82, 94
 - operating mode 82
 - PWM mode 85, 94
 - reading the timer count values 90
 - reload high and low byte registers 91
 - timer control register definitions 90
 - timer output signal operation 90
- timers 0-3
 - control 0 registers 93
 - control 1 registers 94
 - high and low byte registers 90, 92
- TM 247
- TMX 247
- transmit
 - IrDA data 126
- transmit interrupt 145
- transmitting UART data-interrupt-driven method 106
- transmitting UART data-pollled method 105
- TRAP 249

U

- UART 4

- architecture 103
- asynchronous data format without/with parity 105
- baud rate generator 113
- baud rates table 122
- control register definitions 114
- controller signals 15
- data format 104
- interrupts 111
- multiprocessor mode 109
- receiving data using interrupt-driven method 108
- receiving data using the polled method 107
- transmitting data using the interrupt-driven method 106
- transmitting data using the polled method 105
- x baud rate high and low registers 120
- x control 0 and control 1 registers 117
- x status 0 and status 1 registers 115, 116

- UxBRH register 121
- UxBRL register 121
- UxCTL0 register 117, 120
- UxCTL1 register 118
- UxRXD register 115
- UxSTAT0 register 115
- UxSTAT1 register 117
- UxTXD register 114

V

- vector 243
- voltage brown-out reset (VBR) 50

W

- watch-dog timer
 - approximate time-out delay 98
 - approximate time-out delays 97
 - CNTL 50
 - control register 100
 - electrical characteristics and timing 228
 - interrupt in normal operation 98
 - interrupt in STOP mode 98
 - operation 97

- refresh 98, 248
- reload unlock sequence 99
- reload upper, high and low registers 101
- reset 51
- reset in normal operation 99
- reset in STOP mode 99
- time-out response 98
- WDTCTL register 100
- WDTH register 102
- WDTL register 102
- working register 243
- working register pair 243
- WTDU register 102

X

- X 243
- XOR 249
- XORX 249

Z

- Z8 Encore!
 - block diagram 3
 - features 1
 - introduction 1
 - part selection guide 2



Customer Support

For answers to technical questions about the product, documentation, or any other issues with Zilog's offerings, please visit Zilog's Knowledge Base at <http://www.zilog.com/kb>.

For any comments, detail technical questions, or reporting problems, please visit Zilog's Technical Support at <http://support.zilog.com>.