

- 1
- 2
- 3
- 4
- 5
- 6
- 7
- 8
- 9
- 10
- 11
- 12
- 13
- 14
- 15
- 16
- 17
- 18

**MATERIAL**

Transparent polyamide based (PA-T) technopolymer. Highly resistant to shocks, solvents, oils with additives, aliphatic and aromatic hydrocarbons, petrol, naphtha, phosphoric esters.  
Avoid contact with alcohol or detergents containing alcohol.

**SCREWS, NUTS AND WASHERS**

Zinc-plated steel.

**PACKING RINGS**

Step-shaped for the seal on the reservoir walls and NBR synthetic rubber O-ring screw underhead.  
Suggested roughness of the packing ring application surface Ra = 3 µm.

**SENSOR BRACKET**

Watertight in glass-fibre reinforced polyamide based (PA) technopolymer, black colour, with MAX temperature sensor (80°C).  
For a correct assembly see Warnings (on page 1789).

**SWIVELLING CONNECTOR**

With built-in cable gland and contact holder. Front or axial output (high or low) ensuring protection against water sprays (protection class IP 65 according to table EN 60529 on page A-18).

**CONTRAST SCREEN**

White lacquered aluminium. The housing, in the appropriate external rear slot, guarantees the best protection from direct contact with fluid. It can be taken out from the inclined side, before assembly to allow the insertion of level lines or words.

**STANDARD EXECUTIONS**

- **HCV-ST-NO**: with electric contact normally open (NO).
- **HCV-ST-NC**: with electric contact normally closed (NC).

**MAXIMUM CONTINUOUS WORKING TEMPERATURE**

90°C (with oil).

**FEATURES AND PERFORMANCES**

In addition to the visual control, HCV-ST column level indicator, generates an electric signal when the temperature reaches the pre-set degrees (80°C).  
Ultrasound welding to guarantee a perfect seal.  
Maximum fluid level visibility even from side positions.  
Lens effect for a better visibility of the fluid level.

**TECHNICAL DATA**

In laboratory tests carried out with mineral oil type CB68 (according to ISO 3498) at 23°C for a limited period of time, the weld stood up to: 18 bar (HCV.76), 18 bar (HCV.127) and 12 bar (HCV.254).

For use with other fluids and under different pressure and temperature conditions, please contact ELESA Technical Department.

In any case we suggest to verify the suitability of the product under the actual working conditions.

**SPECIAL EXECUTIONS ON REQUEST**

- Level indicators with stainless steel screws, nuts and washers.
- Level indicators HCV.76 with screws M12.
- Level indicators for use with fluids containing alcohol.
- UV resistant transparent technopolymer level indicators.
- MAX temperature electrical sensor with trigger threshold at 70°C or 90°C.



ELESA Original design

**FUNCTIONING OF THE MAX TEMPERATURE SENSOR**

- **HCV-ST-NO**: the electrical contact closes when the pre-set temperature is reached at 80°C.
- **HCV-ST-NC**: the electrical contact opens when the pre-set temperature at 80°C is reached.

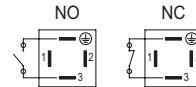

Electrical features	MAX temperature sensor	
Power supply	AC/DC	
Electric contacts	NO normally open NC normally closed	
Voltage / Maximum current	250 Vac - 2 A	(resistive loads)
	115 Vac- 3A	
	24 Vdc - 3 A	
	12 Vdc - 4 A	
Minimum current	500 mA	
Cable gland	Pg 7 (for cables in sheath with Ø 6 or 7 mm)	
Conductors cross-section	Max. 1.5 mm <sup>2</sup>	

**CONNECTOR ASSEMBLY INSTRUCTIONS**

1. Remove the connector from the indicator by unscrewing the set screw placed on the connector, take the contact holders out and loosen the cable gland.
2. Slip on the cable into the connector (standard connector) and connect the wires to the terminals 3 and earth of the contact holder.
3. Assemble by pressing the contact holder into the connector in the required position.
4. Screw the connectors to the indicator and then tighten the cable glands.

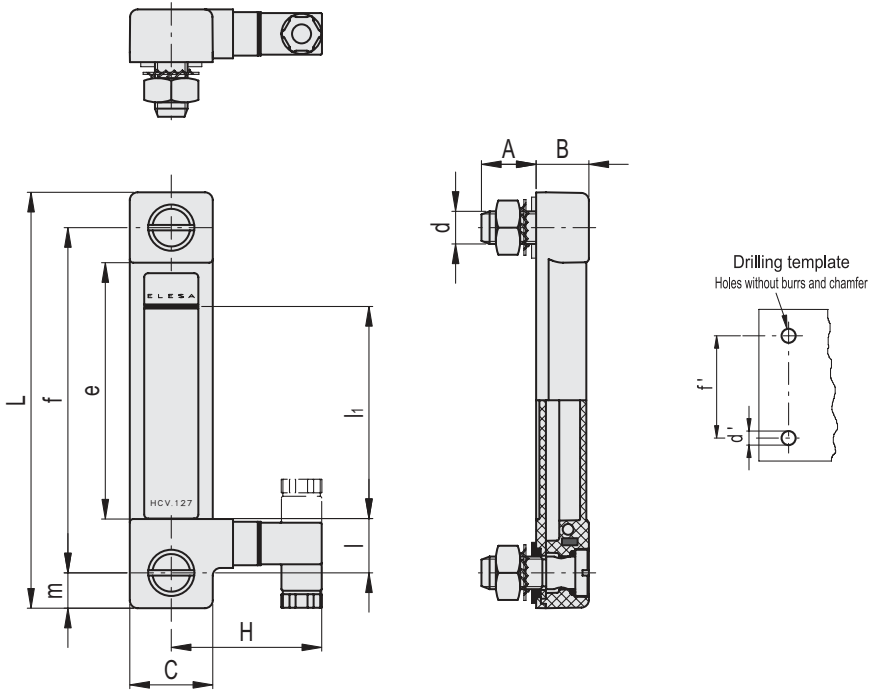
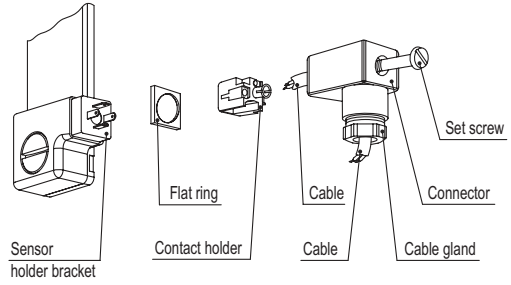

Conversion Table	
1 mm = 0.039 inch	
mm	inch
76	2.99
127	5.00
254	10.00

Code	Description	f	d	A	B	C	H	L	e	l	li	m	d <sup>±0.2</sup>	f <sub>±0.2</sub>	C# [Nm]	⚖️
11041	HCV.76-ST-NO-M10	76	M10	20	19.5	30.5	55	102	43.5	20	26.5	13	10.5	76	12	133
11042	HCV.76-ST-NC-M10	76	M10	20	19.5	30.5	55	102	43.5	20	26.5	13	10.5	76	12	133
11112	HCV.127-ST-NO-M12	127	M12	20	19.5	30.5	55	153	97	20	78.5	13	12.5	127	12	149
11113	HCV.127-ST-NC-M12	127	M12	20	19.5	30.5	55	153	97	20	78.5	13	12.5	127	12	149
11122	HCV.254-ST-NO-M12	254	M12	20	19.5	30.5	55	280	224	20	205.5	13	12.5	254	12	176
11123	HCV.254-ST-NC-M12	254	M12	20	19.5	30.5	55	280	224	20	205.5	13	12.5	254	12	176

# Maximum tightening torque.

