



FEATURES:

- Wide 4:1 Input Voltage Range
- High efficiency up to 88%
- 1500 & 2250VDC Isolation
- Over Current Protection
- Design to meet EN50155
- Operating Temperature -40°C to +85°C
- Output Over Voltage protection
- Continuous Short Circuit Protection
- Input Under Voltage Protection

Models
Single output



Model	Input Voltage (V)	Output Voltage (V)	Output Current max (mA)	Isolation (VDC)	Max Capacitive Load (uF)	Efficiency (%)
AM6CW-2403S-NZ	9-36	3.3	1500	1500	1800	79
AM6CW-2405S-NZ	9-36	5	1200	1500	1000	83
AM6CW-2409S-NZ	9-36	9	667	1500	680	85
AM6CW-2412S-NZ	9-36	12	500	1500	470	87
AM6CW-2415S-NZ	9-36	15	400	1500	220	87
AM6CW-2424S-NZ	9-36	24	250	1500	100	88
AM6CW-4803S-NZ	18-75	3.3	1500	1500	1800	79
AM6CW-4805S-NZ	18-75	5	1200	1500	1000	83
AM6CW-4812S-NZ	18-75	12	500	1500	470	87
AM6CW-4815S-NZ	18-75	15	400	1500	220	88
AM6CW-4824S-NZ	18-75	24	250	1500	100	88
AM6CW-11005SH22-NZ	40-160	5	1200	2250	1000	80
AM6CW-11012SH22-NZ	40-160	12	500	2250	470	84
AM6CW-11015SH22-NZ	40-160	15	400	2250	220	85
AM6CW-11024SH22-NZ	40-160	24	250	2250	100	86

Models
Dual output

Model	Input Voltage (V)	Output Voltage (V)	Output Current max (mA)	Isolation (VDC)	Max Capacitive Load(uF)	Efficiency (%)
AM6CW-2405D-NZ	9-36	±5	±600	1500	±470	83
AM6CW-2412D-NZ	9-36	±12	±250	1500	±100	87
AM6CW-2415D-NZ	9-36	±15	±200	1500	±100	87
AM6CW-2424D-NZ	9-36	±24	±125	1500	±100	87
AM6CW-4805D-NZ	18-75	±5	±600	1500	±470	83
AM6CW-4812D-NZ	18-75	±12	±250	1500	±100	87
AM6CW-4815D-NZ	18-75	±15	±200	1500	±100	88
AM6CW-11005DH22-NZ	40-160	±5	±600	2250	±470	80
AM6CW-11012DH22-NZ	40-160	±12	±250	2250	±100	84
AM6CW-11015DH22-NZ	40-160	±15	±200	2250	±100	85

Note:
 * Add suffix “-ST” for optional screw terminal bottom plate.
 ** Add suffix “-STD” for optional DIN Rail screw terminal bottom plate.
 *** For 110V input models, add suffix “-K” for optional heatsink.
 **** For 110V input models, add suffix “-K-ST” for optional heat sink with screw terminal bottom plate.
 ***** For 110V input models, add suffix “-K-STD” for optional heat sink with DIN Rail screw terminal bottom plate.
 ***** -ST and -STD bottom plates come with the reverse polarity protection and will reduce the efficiency by 2%.
 ***** For 24V and 48V input models with -ST or -STD option, the input under voltage protection threshold and minimum input voltage will increase by 1V.

NOTE: All specifications in this datasheet are measured at an ambient temperature of 25°C, humidity<75%, nominal input voltage and at rated output load unless otherwise specified.

Input Specifications

Parameters	Nominal	Typical	Maximum	Units
Voltage range	24	9-36	40	VDC
	48	18-75	80	
	110	40-160	170	
Filter	Pi			
Absolute maximum rating (1s)	24		-0.7 - 50	VDC
	48		-0.7 - 100	
	110		-0.7 - 180	
No load input current	24		12	mA
	48, 110		8	
Input reflected current	24, 48	20		mA
	110	25		
Input under voltage turn off	24	6.5		VDC
	48	15.5		
	110	33		
Startup time	110	10		ms

Isolation Specifications

Parameters	Conditions	Typical	Rated	Units
Tested I/O voltage	60 sec, <1mA		1500 & 2250	VDC
Tested I, O / Case voltage	60 sec, <1mA, 110Vin models		1600	VDC
Resistance	500VDC		>1000	MOhm
Capacitance	I/O, 100KHz/0.1V	1000		pF

Output Specifications

Parameters	Conditions	Typical	Maximum	Units
Voltage accuracy		±1	±3	%
Over voltage protection		110-160		% of Vout
Over current protection	24 & 48Vin models	110-190		% of Iout
	110Vin models	120-210		% of Iout
Short Circuit protection	Continuous			
Short circuit restart	Auto-Recovery			
Line voltage regulation	Full load, LL to HL, single output	±0.2	±0.5	% of Vin
	Full load, LL to HL, dual output	±0.5	±1	% of Vin
Load voltage regulation	0-100% load, 110Vin single output	±0.5	±1	%
	5- 100% load, 24/48Vin single output	±0.5	±1	%
	5% to 100% load, dual output	±0.5	±1.5	%
Cross Regulation	24/48Vin, output1 50% load, output2 10-100% load		±5	%
	110Vin, output1 50% load, output2 25-100% load		±10	%
Temperature coefficient	100% load		±0.03	%/°C
Ripple & Noise*	24/48Vin, 20MHz bandwidth, 5-100% load	60	85	mV p-p
	110Vin, 20MHz bandwidth, 5-100% load	50	100	mV p-p
Transient recovery time	25% load step change	300	500	µS
Transient recovery deviation	25% load step change		±8	%

* Please refer to the application note for specific detail.

General Specifications

Parameters	Conditions	Typical	Maximum	Units
Switching frequency*	100% load	300		KHz
Operating temperature	See derating graph	-40 to +85		°C
Storage temperature		-55 to +125		°C
Cooling	Free air convection			
Humidity			95	% RH
Case material	Aluminum Alloy			
Weight	Pin mountable	12.5		g
	With optional -ST mounting plate:	36		
	With optional -STD mounting plate:	56		
	With optional -K Pin mountable	17		
	With optional -ST-K mounting plate:	40		
	With optional -STD-K mounting plate:	59		

Dimensions (L x W x H)	Pin mountable With optional -ST mounting plate: With optional -STD mounting plate: With optional -K Pin mountable With optional -ST-K mounting plate: With optional -STD-K mounting plate:	1 x 1 x 0.46inches, 25.40 x 25.40 x 11.70mm 2.99 x 1.24 x 0.84inches, 76.00 x 31.50 x 21.20mm 2.99 x 1.24 x 1.02inches, 76.00 x 31.50 x 25.80mm 1 x 1 x 0.64inches, 25.40 x 25.40 x 16.20mm 2.99 x 1.24 x 0.99inches, 76.00 x 31.50 x 25.20mm 2.99 x 1.24 x 1.17inches, 76.00 x 31.50 x 29.80mm
MTBF	>1,000,000 hours (MIL-HDBK -217F, Ground Benign, t=+25°C)	
Soldering temperature	1.5mm from case for 10 sec	300 °C

Environmental Specifications

Parameters		
Vibration	Test mode	IEC61373 - Category 1, Grade B

Safety Specifications

Parameters	
Approvals	CE, UL EN/IEC/UL60950-1 Design to meet EN62368 (except 110Vin single output models), EN50155
EMI - Conducted and radiated emission	EN55032, class A (24 & 48Vin models only, without external components) EN55032, class B (24 & 48Vin models with EMC circuit 3-B) (110Vin models with EMC circuit 1 or 2-B) EN50121-3-2 150kHz-500kHz 99dBuV (24 & 48Vin models with EMC circuit 3-B) * EN55016-2-1 500kHz-30MHz 93dBuV (24 & 48Vin models with EMC circuit 3-B) * EN50121-3-2 30MHz-230MHz 40dBuV/m at 10m (24 & 48Vin models with EMC circuit 3-B) * EN55016-2-1 230MHz-1GHz 47dBuV/m at 10m (24 & 48Vin models with EMC circuit 3-B) *
Electrostatic Discharge Immunity	IEC61000-4-2, Contact ±4KV, Criteria B (24 & 48Vin models only) IEC61000-4-2, Contact ±6KV, Air ±8KV, Criteria B (110Vin models only) EN50121-3-2 Contact ±6KV, Air ±8KV, Criteria A (24 & 48Vin models only) EN50121-3-2 Contact ±6KV, Air ±8KV, Criteria B (110Vin models only) *
RF, Electromagnetic Field Immunity	IEC61000-4-3, 10V/m, Criteria A (24 & 48Vin models only) IEC61000-4-3, 20V/m, Criteria A (110Vin models only) EN50121-3-2 20V/m, Criteria A *
Electrical Fast Transient/Burst Immunity	IEC61000-4-4, ±2KV, Criteria B (24 & 48Vin models only, with EMC circuit 3-A) IEC61000-4-4, ±4KV, Criteria B (110Vin models only, with EMC circuit 1 or 2-A) EN50121-3-2 ±2kV, 5/50ns, 5KHz, Criteria A (24 & 48Vin models with EMC circuit 3-A) *
Surge Immunity	IEC61000-4-5, L-L ±2KV, Criteria B, (24 & 48Vin models only, with EMC circuit 3-A) IEC61000-4-5, L-L ±2KV, L-G ±4KV, Criteria B (110Vin models only, with EMC circuit 1) EN50121-3-2 L-L ±1KV (42Ω 0.5μF) (24 & 48Vin models only, with EMC circuit 3-A) EN50121-3-2 L-L ±1KV (42Ω 0.5μF), L-G ±2KV (42Ω 0.5μF), Criteria B (110Vin models only) *
RF, Conducted Disturbance Immunity	IEC61000-4-6, 3 Vrms, Criteria A (24 & 48Vin models only) IEC61000-4-6, 10 Vrms, Criteria A (110Vin models only) EN50121-3-2 0.15MHz-80MHz 10Vr.m.s, Criteria A*
Voltage dips, short interruptions, and voltage variations	IEC61000-4-29, 0-70%, Criteria B (24 & 48Vin models only)

* For 110Vin models, EN50155, EN50121-3-2 and EN55016-2-1 are measured with a 100μF/200V input capacitor or AMFW72-13NZ.

Derating

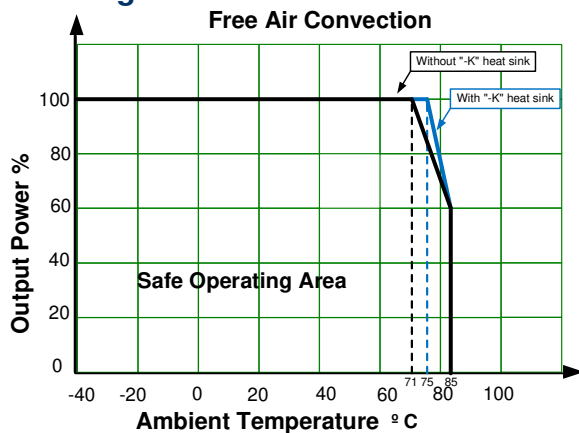

Dimensions
24, 48Vin models

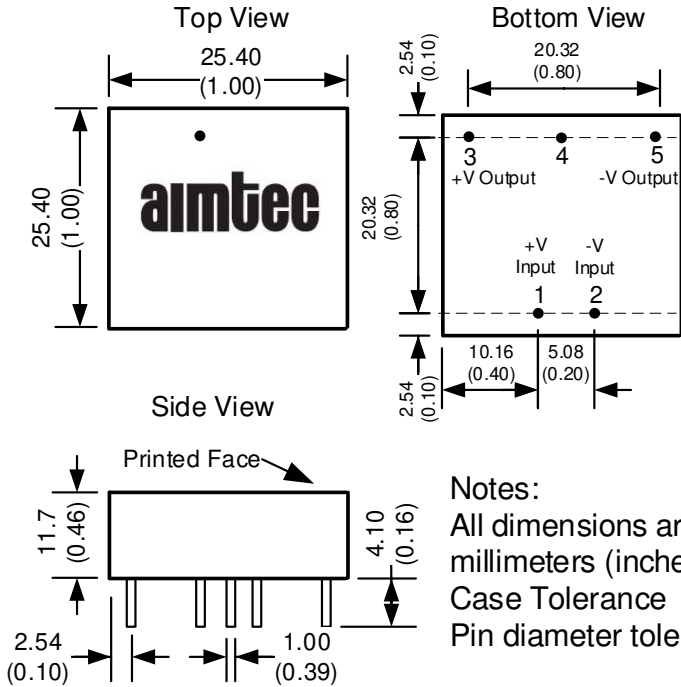

Notes:
All dimensions are typical in millimeters (inches).
Case Tolerance ± 0.5 (± 0.02)
Pin diameter tolerance ± 0.1 (± 0.004)

Pin Out Specifications

24, 48Vin models		
Pin	Single	Dual
1	+V Input	+V Input
2	-V Input	-V Input
3	+V Output	+V Output
4	No pin	Common
5	-V Output	-V Output

110Vin models

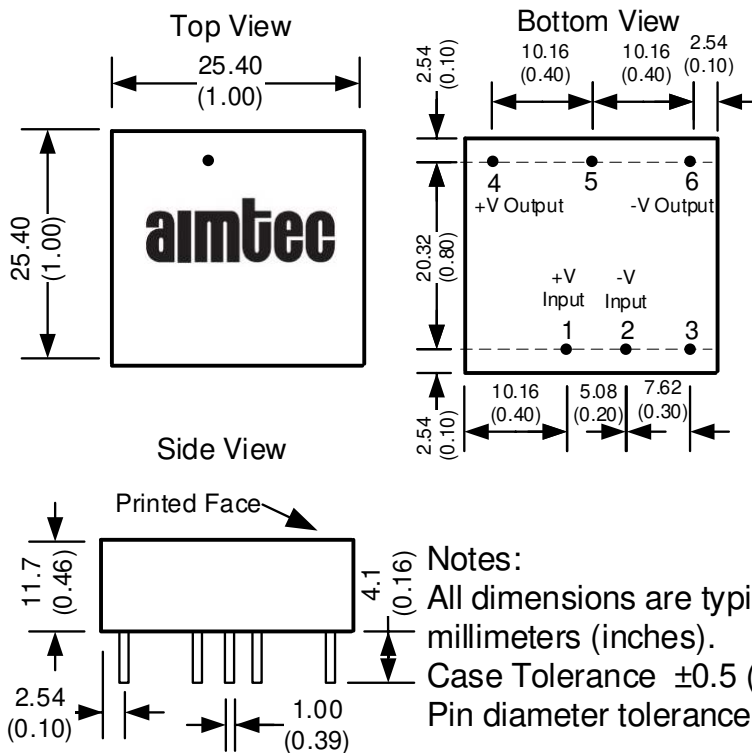

Notes:
All dimensions are typical in millimeters (inches).
Case Tolerance ± 0.5 (± 0.02)
Pin diameter tolerance ± 0.1 (± 0.004)

110Vin models		
Pin	Single	Dual
1	+ V input	+ V input
2	- V input	- V input
3	No pin	On/Off Control
4	+ V output	+ V output
5	No pin	Common
6	- V output	- V output

Heatsink Option: AM6CW-NZ-K
110Vin models

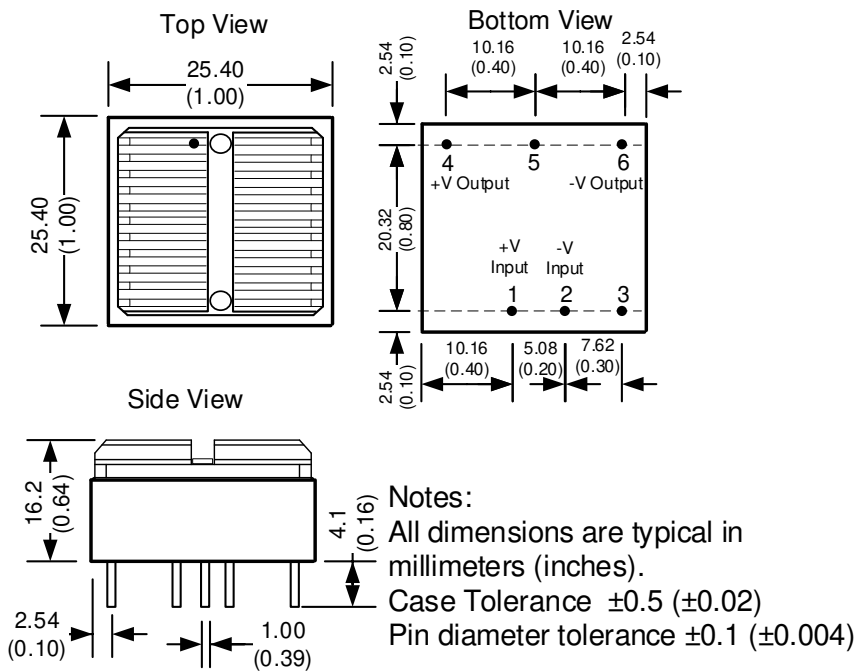

110Vin models		
Pin	Single	Dual
1	+ V input	+ V input
2	- V input	- V input
3	No pin	On/Off Control
4	+ V output	+ V output
5	No pin	Common
6	- V output	- V output

Screw Terminal Option: AM6CW-NZ-ST

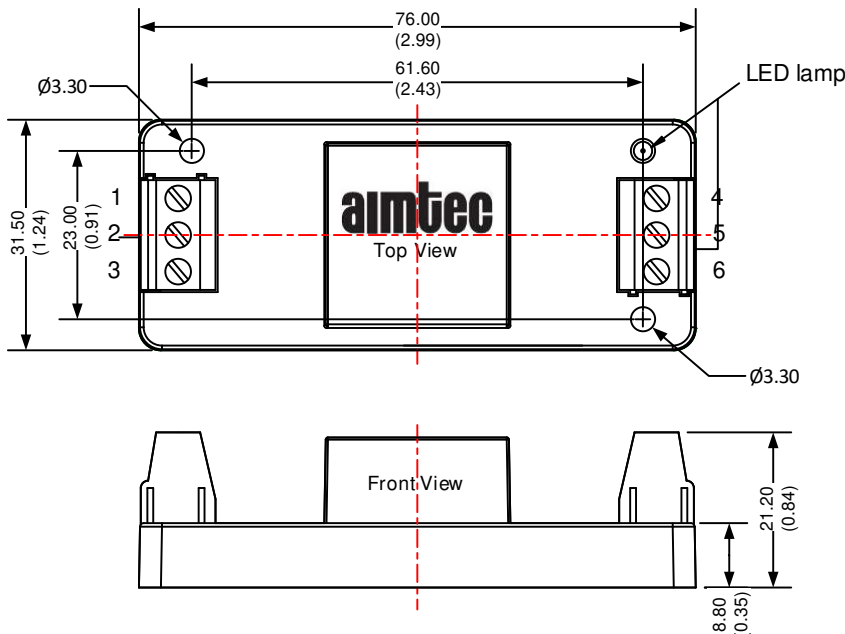

Note:
Unit: mm (inch)
Wire range: 24-12 AWG
Tightening torque: Max 0.4 N*m
General tolerances: ± 0.50 (± 0.02)

24, 48Vin models		
Pin	Single	Dual
1	NC	NC
2	-V Input	-V Input
3	+V Input	+V Input
4	-V Output	-V Output
5	NC	Common
6	+V Output	+V Output

110Vin models		
Pin	Single	Dual
1	NC	On/Off Control
2	-V Input	-V Input
3	+V Input	+V Input
4	-V Output	-V Output
5	NC	Common
6	+V Output	+V Output

Screw Terminal with heatsink Option: AM6CW-NZ-K-ST

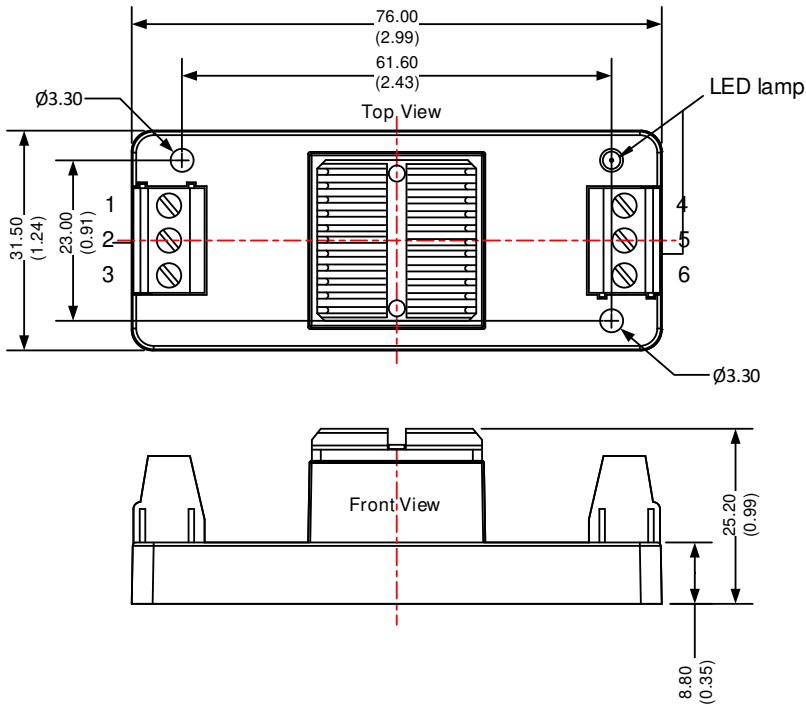

110Vin models		
Pin	Single	Dual
1	NC	On/Off Control
2	-V Input	-V Input
3	+V Input	+V Input
4	-V Output	-V Output
5	NC	Common
6	+V Output	+V Output

Note:
 Unit: mm (inch)
 Wire range: 24-12 AWG
 Tightening torque: Max 0.4 N*m
 General tolerances: ± 0.50 (± 0.02)

DIN-RAIL Option: AM6CW-NZ-STD

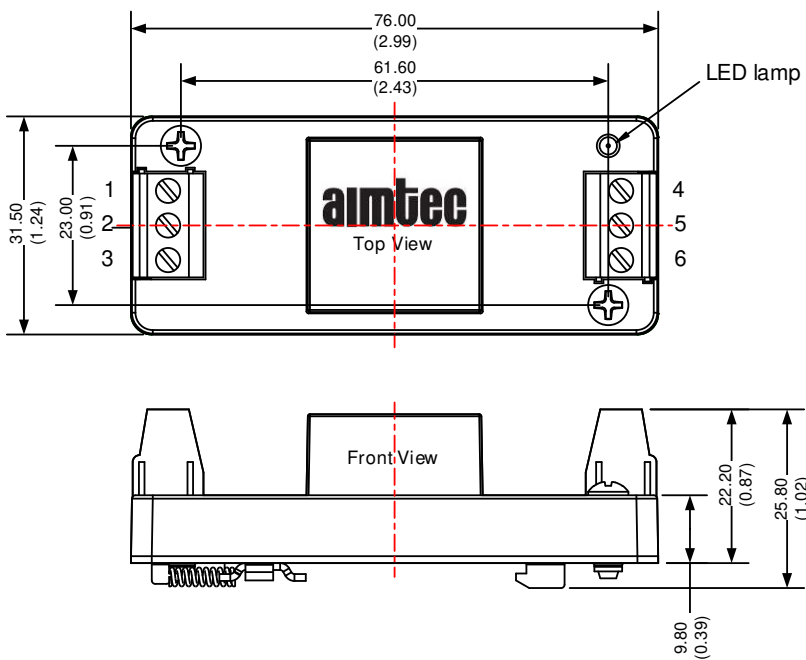

24, 48Vin models		
Pin	Single	Dual
1	NC	NC
2	-V Input	-V Input
3	+V Input	+V Input
4	-V Output	-V Output
5	NC	Common
6	+V Output	+V Output

110Vin models		
Pin	Single	Dual
1	NC	On/Off Control
2	-V Input	-V Input
3	+V Input	+V Input
4	-V Output	-V Output
5	NC	Common
6	+V Output	+V Output

Note:
 Unit: mm (inch)
 Mounting rail: TS35
 Wire range: 24-12 AWG
 Tightening torque: Max 0.4 N*m
 General tolerances: ± 0.50 (± 0.02)

DIN-RAIL with heatsink Option: AM6CW-NZ-K-STD

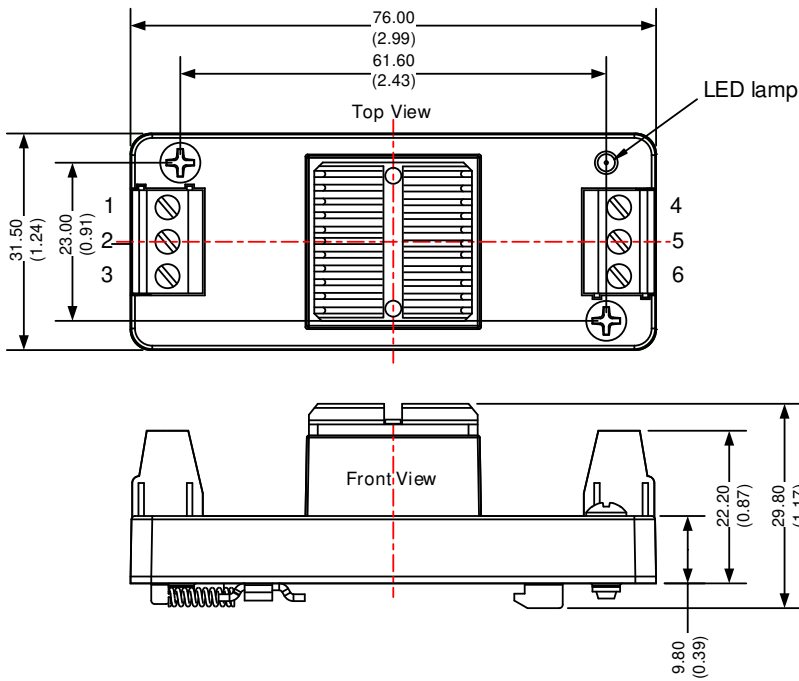

110Vin models		
Pin	Single	Dual
1	NC	On/Off Control
2	-V Input	-V Input
3	+V Input	+V Input
4	-V Output	-V Output
5	NC	Common
6	+V Output	+V Output

Note:
Unit: mm (inch)
Mounting rail: TS35
Wire range: 24-12 AWG
Tightening torque: Max 0.4 N*m
General tolerances: ±0.50 (±0.02)

Typical application circuit

Single output models

Dual output models

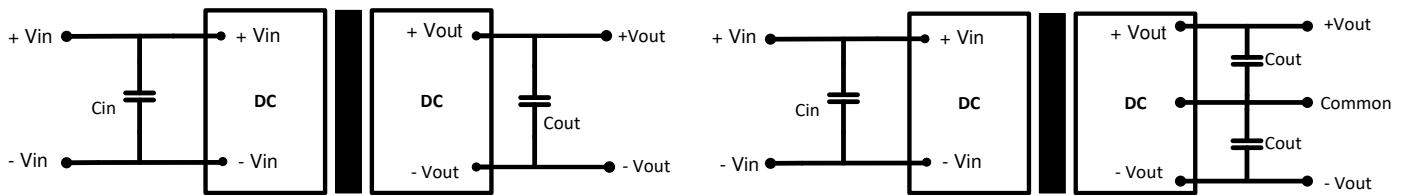

Vin	Cin	Cout
24V	100µF	10µF
48V, 110V	10-47µF	10µF

Recommended EMC circuit 1 (110Vin models)

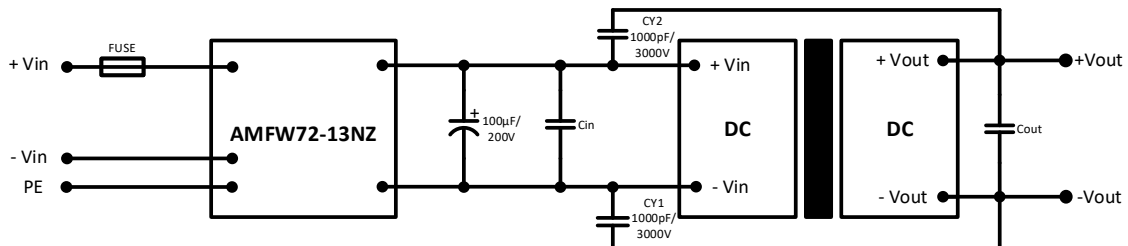

Recommended EMC circuit 2 (110Vin models)

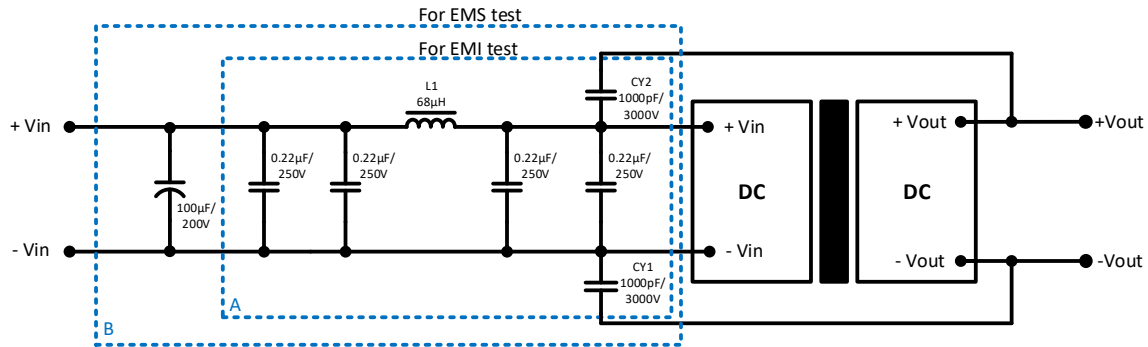

Recommended EMC circuit 3 (24 & 48 Vin models)

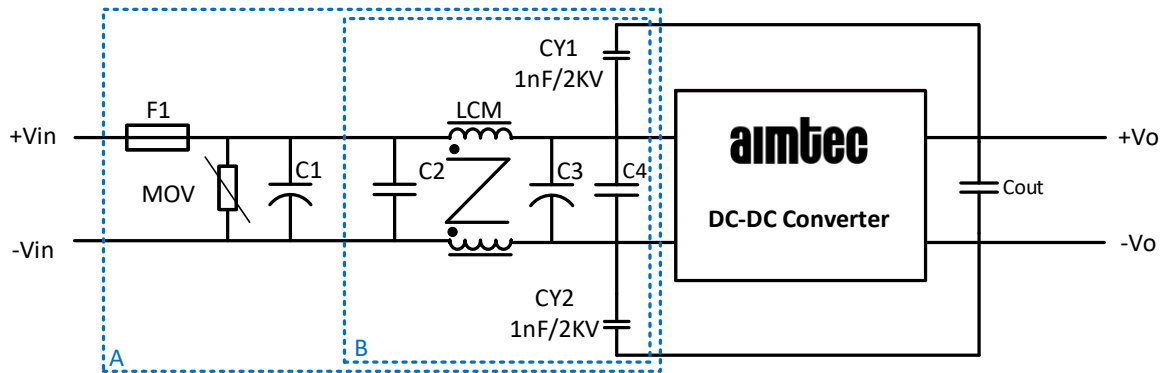

Notes: Part A for EMI filtering and Part B is used for EMS filtering.

Vin	MOV	C1	C2	C3	C4	LCM
24V	S20K30	680 µF / 50V	1 µF / 50V	330 µF / 50V	4.7 µF / 50V	4.7mH
48V	S14K60	680 µF / 100V	1 µF / 100V	330 µF / 100V	4.7 µF / 100V	4.7mH

NOTE: 1. Datasheets are updated as needed and as such, specifications are subject to change without notice. Once printed or downloaded, datasheets are no longer controlled by Aimtec; refer to www.aimtec.com for the most current product specifications. 2. Product labels shown, including safety agency certifications on labels, may vary based on the date manufactured. 3. Mechanical drawings and specifications are for reference only. 4. All specifications are measured at an ambient temperature of 25°C, humidity < 75%, nominal input voltage and at rated output load unless otherwise specified. 5. Aimtec may not have conducted destructive testing or chemical analysis on all internal components and chemicals at the time of publishing this document. CAS numbers and other limited information are considered proprietary and may not be available for release. 6. This product is not designed for use in critical life support systems, equipment used in hazardous environments, nuclear control systems or other such applications which necessitate specific safety and regulatory standards other than the ones listed in this datasheet. 7. Warranty is in accordance with Aimtec's standard Terms of Sale available at www.aimtec.com.