

Device Features

- +5V/680mA at operating bias condition
- Gain = 27.3 dB @ 1850 MHz
- P1dB = 33.1 dBm @ 1850MHz
- LTE 10M ACLR = 23.5dBm Output Power at -50dBc @ 1850MHz
- Intergrated interstage matching
- Green/RoHS2-compliant QFN5x5 SMT package



Product Description

The BMT332 is a high dynamic range two-stage power amplifier housed in RoHS2 compliant 20 pin, 5x5mm QFN package. The BMT332 uses a high reliability InGaP/GaAs HBT process technology. The BMT332 is designed for use where high linearity and gain is required. The BMT332 is able to deliver over 23 dBm output power from 700 to 2400MHz while maintaining superior ACLR performance with a few external matching components. All devices are 100% RF/DC screened.

Applications

- Base station /Repeaters Infrastructure
- Commercial/Industrial/Military wireless system
- LTE / WCDMA /CDMA Wireless Infrastructure

Application Circuits

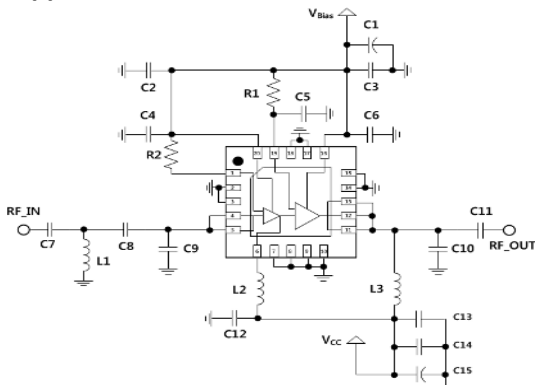

*External matching circuit: refer to the page 5 to 20.

Electrical Specifications

Device performance _ measured on a BeRex evaluation board at 25°C, Vc=5V, 50 Ω system.

Parameter	Conditions	Min	Typ	Max	Unit
Operational Frequency Range		700		2400	MHz
Test Frequency			1850		MHz
Gain		25.8	27.3		dB
Input Return Loss			-30.0		dB
Output Return Loss			-11.5		dB
Output IP3	23 dBm/tone, Δf=1 MHz	46.0	49.0		dBm
Output P1dB		32.1	33.1		dBm
LTE 10M ACLR*		22.5	23.5		dBm
WCDMA ACLR*		22.7	23.7		dBm
Noise Figure			5.6		dB

*ACLR Channel Power measured at -50dBc.

- LTE set-up: 3GPP LTE, FDD E-TM3.1, 10MHz BW, ±5MHz offset, PAR 9.75 @0.01% Prob.

- WCDMA set-up: 3GPP WCDMA, TM1+64DPCH, +5MHz offset, PAR 9.78 at 0.01% Prob.

Recommended Operating Conditions

Parameter	Min	Typ	Max	Unit
Bandwidth	700		2400	MHz
I _{bias} @ (I _{REF1&2} + I _{B1&2})	27	33	39	mA
I _c @ (I _{c1} + I _{c2})	550	680	810	mA
V _{CC} /V _{Bias}	4.75	5.0	5.25	V
R _{TH}		7.9		°C/W
Operating Case Temperature	-40		+85	°C

Electrical specifications are measured at specified test conditions.

Specifications are not guaranteed over all recommended operating conditions.

Absolute Maximum Ratings

Parameter	Rating	Unit
Storage Temperature	-55 to +155	°C
Junction Temperature	+180	°C
Supply Voltage	+6	V
Supply Current	2000	mA
Input RF Power	23	dBm

*Operation of this device above any of these parameters may result in permanent damage.

Typical Performance (V_{CC} & $V_{Bias} = +5V$, $I_{CQ} = 680mA$, $T_a = 25^\circ C$)

Parameter	Frequency						Unit
	850	1750	1850	1960	2140	2350	
Gain	33.5	28.0	27.3	26.7	26.0	24.0	dB
S11	-18.0	-30.0	-30.0	-26.0	-17.0	-17.0	dB
S22	-14.5	-11.5	-11.5	-12.0	-11.0	-12.5	dB
OIP3	50.0	50.0	49.0	49.0	47.5	47.5	dBm
P1dB	33.6	33.2	33.1	33.1	33.2	33.1	dBm
LTE 10M ACLR	23.4	23.4	23.5	23.2	23.8	23.2	dBm
WCDMA ACLR	23.5	23.7	23.7	23.5	24.0	23.5	dBm
Noise Figure	7.0	5.6	5.6	5.5	5.5	5.3	dB

V-I Characteristics

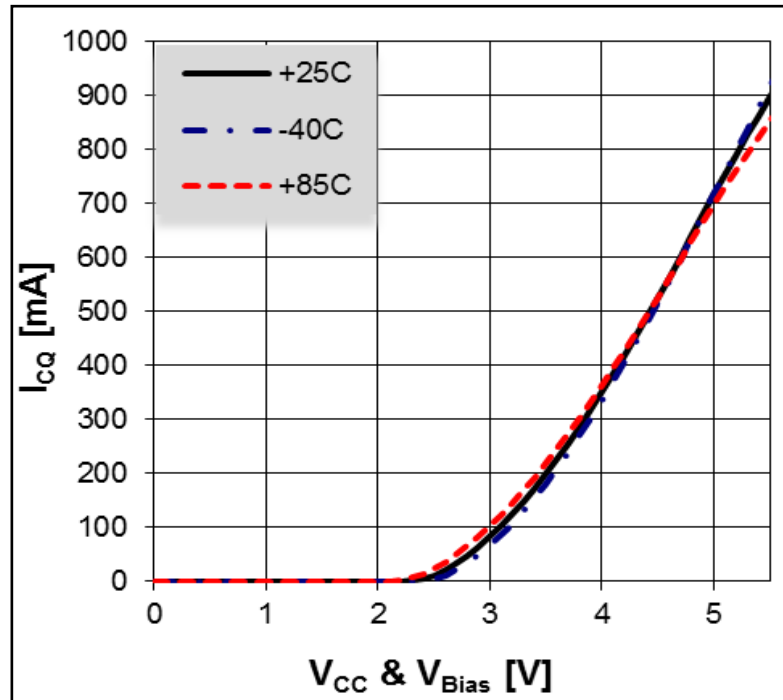

Pin Configuration

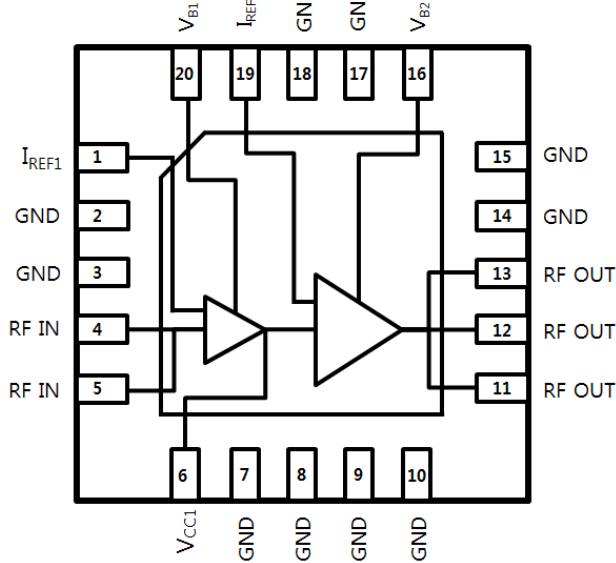

Pin No.	Label
1	I_{REF1}
4,5	RF IN
6	V_{CC1}
11,12,13	RF OUT/ V_{CC2}
16	V_{B2}
19	I_{REF2}
20	V_{B1}
2,3,7,8,9,10,14,	GND
Backside Paddle	GND

BeRex Evaluation Board

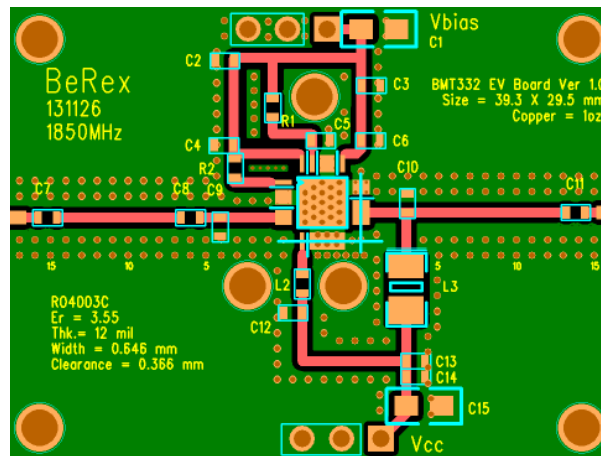
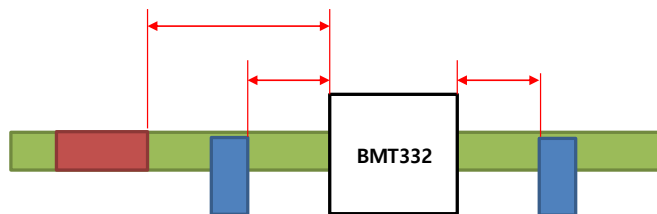
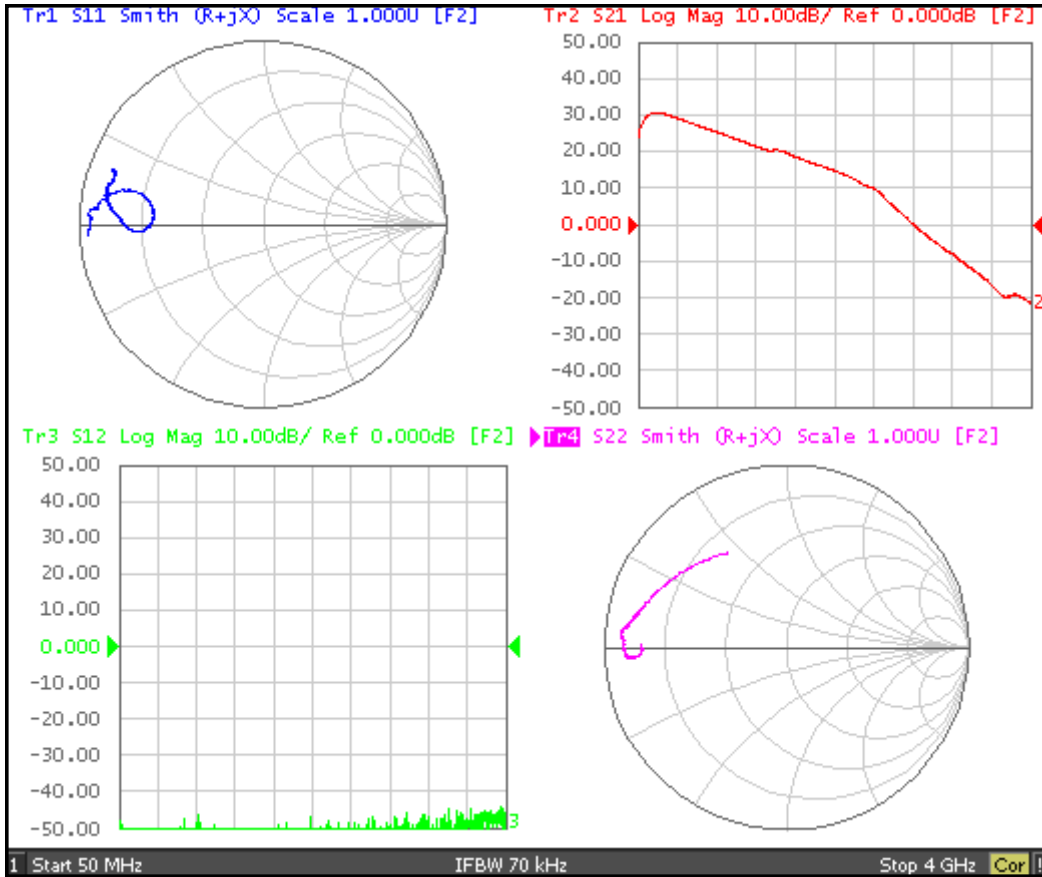

Figure about the reference position of components



Typical Device Data

S-parameters (V_{cc} & V_{Bias} = +5V, I_{cq} = 680mA, T_a = 25°C)



S-Parameter

(V_{cc} & V_{Bias} = 5.0V, I_{cq} = 680mA, T_a = 25 °C, calibrated to device leads)

Freq [MHz]	S11 [Mag]	S11 [Ang]	S21 [Mag]	S21 [Ang]	S12 [Mag]	S12 [Ang]	S22 [Mag]	S22 [Ang]
100	0.913	173.761	24.816	32.166	0.003	79.828	0.801	-178.428
500	0.619	171.121	26.921	-92.025	0.001	-44.058	0.869	-176.093
1000	0.701	-177.176	15.441	-178.364	0.002	59.383	0.879	-177.489
1500	0.784	177.684	10.073	107.582	0.001	119.430	0.895	179.724
2000	0.826	174.821	5.629	28.494	0.001	52.589	0.901	177.048
2500	0.877	167.581	2.533	-60.751	0.002	52.748	0.909	174.926
3000	0.856	164.082	0.614	-113.048	0.003	73.959	0.876	171.808
3500	0.863	160.570	0.198	-148.521	0.002	48.291	0.800	161.758
4000	0.868	160.252	0.085	179.517	0.004	44.770	0.607	121.233

Application Circuit: 850 MHz

Schematic Diagram	BOM	Marks		
	C1	1206	10uF	Tantalum
	C2	0603	N/A	
	C3	0603	68pF	
	C4	0603	1nF	
	C5	0603	N/A	
	C6	0603	3.3pF	
	C7	0603	100pF	
	C8	0603	5pF	
	C9	0603	N/A	
	C10	0603	10pF	High Q
	C11	0603	100pF	
	C12	0603	1uF	
	C13	0603	100pF	
	C14	0603	1nF	
	C15	1206	10uF	Tantalum
L1	0603	5.6nH		
L2	0603	22nH		
L3	1008	22nH	Coil	
R1	0603	100 Ω	±5%	
R2	0603	270 Ω	±5%	

PCB Diagram	Notice																					
	<p>Below information is subject to change as conditions of the substrate.</p> <table border="1"> <thead> <tr> <th>Reference</th> <th>Object</th> <th>Distance</th> </tr> </thead> <tbody> <tr> <td>Input pin</td> <td>L1</td> <td>8.0mm</td> </tr> <tr> <td>Input pin</td> <td>C8</td> <td>5.3mm</td> </tr> <tr> <td>Output pin</td> <td>C10</td> <td>9.0mm</td> </tr> <tr> <td>Pin 16</td> <td>C3</td> <td>7.2mm</td> </tr> <tr> <td>Pin 16</td> <td>C6</td> <td>2.0mm</td> </tr> <tr> <td>Pin 20</td> <td>C4</td> <td>5.0mm</td> </tr> </tbody> </table>	Reference	Object	Distance	Input pin	L1	8.0mm	Input pin	C8	5.3mm	Output pin	C10	9.0mm	Pin 16	C3	7.2mm	Pin 16	C6	2.0mm	Pin 20	C4	5.0mm
	Reference	Object	Distance																			
Input pin	L1	8.0mm																				
Input pin	C8	5.3mm																				
Output pin	C10	9.0mm																				
Pin 16	C3	7.2mm																				
Pin 16	C6	2.0mm																				
Pin 20	C4	5.0mm																				
	<ol style="list-style-type: none"> Pin 16 & 20 is used for Vce of the inner bias circuit. To eliminate bias line resonance you need above 10mm transmission line and adjust the position of C2, C3, C4, C5 and C6. Also you can adjust spectrum regrowth about bandwidth of signals which you want. C10 : We recommend High-Q capacitor for better output power performance. In this document we used '10pF(251R14S100JV4, EIA 0603) of Johanson Technology. You could change C7 from 100 pF to 0 Ω or a line if you have other DC block front of 																					

Typical Performance
 (V_{CC} & V_{Bias} = +5V, I_{cq} = 680mA, T_a = 25°C)

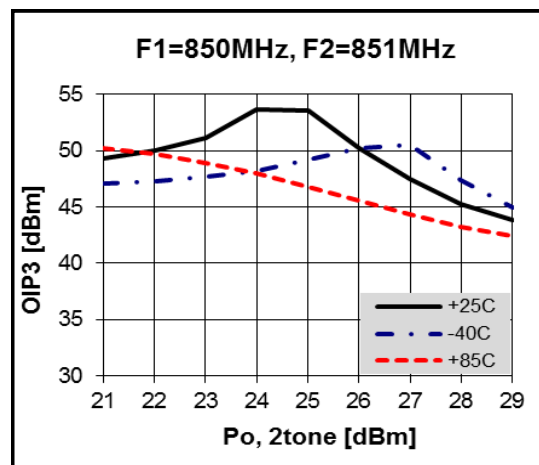
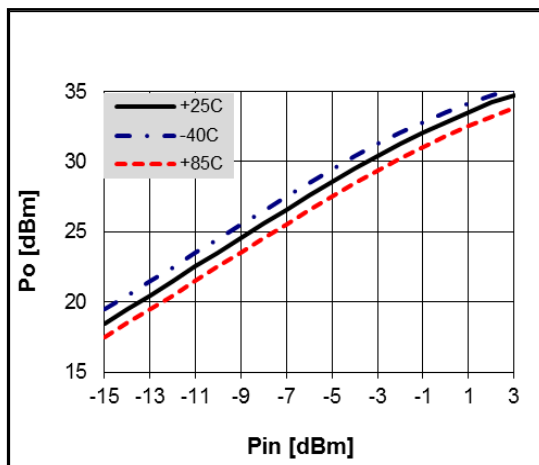
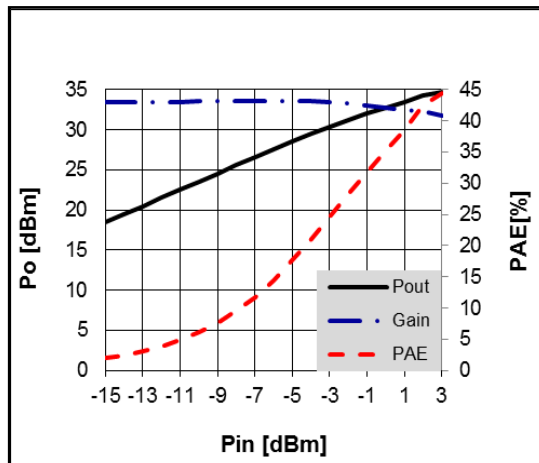
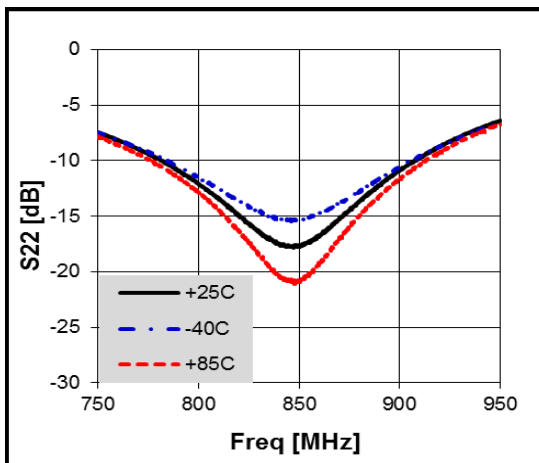
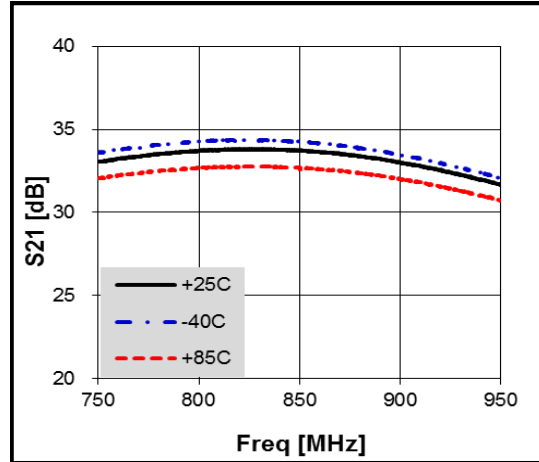
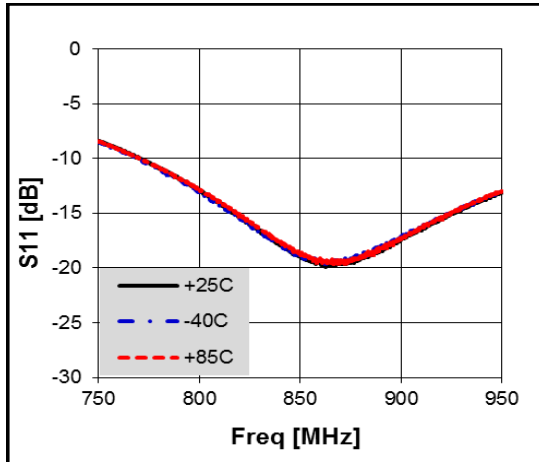

700-2400 MHz 2W High Linearity 5V 2-Stage Power Amplifier

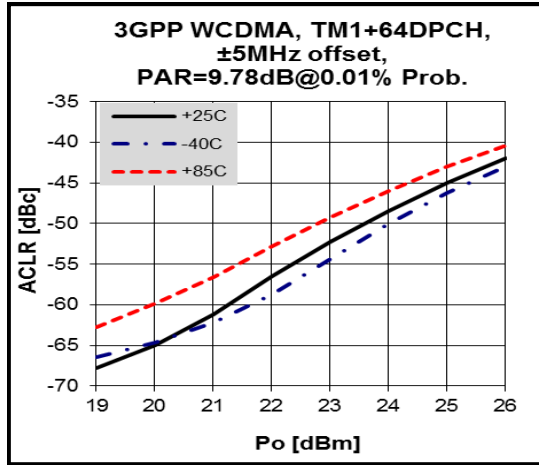

3GPP WCDMA TM1 +64DPCH 1FA

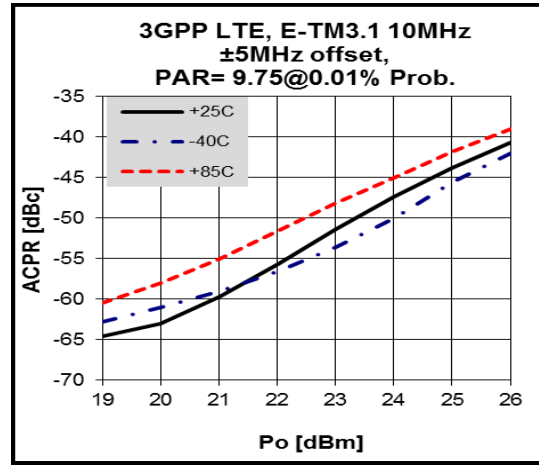

3GPP LTE E-TM3.1 10MHz

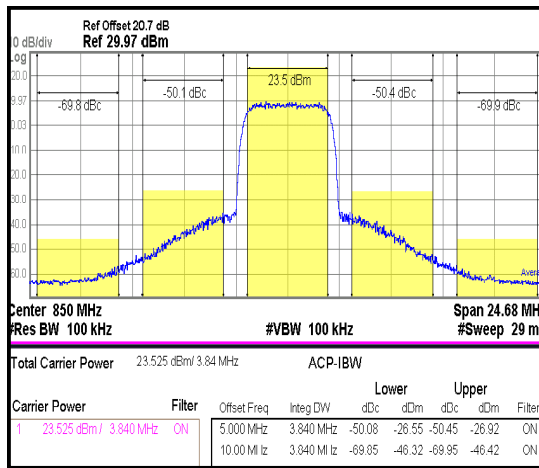

3GPP WCDMA TM1 +64DPCH 4FA

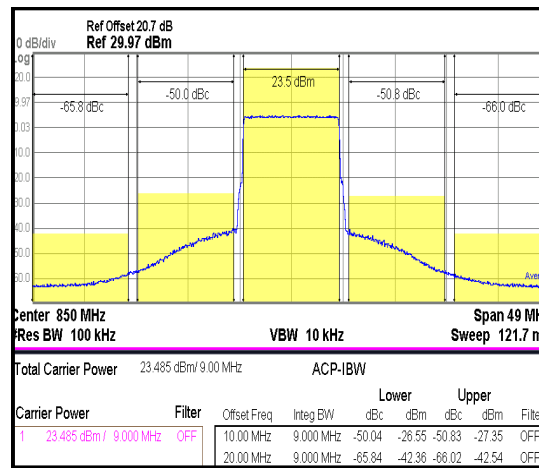

3GPP LTE E-TM3.1 20MHz

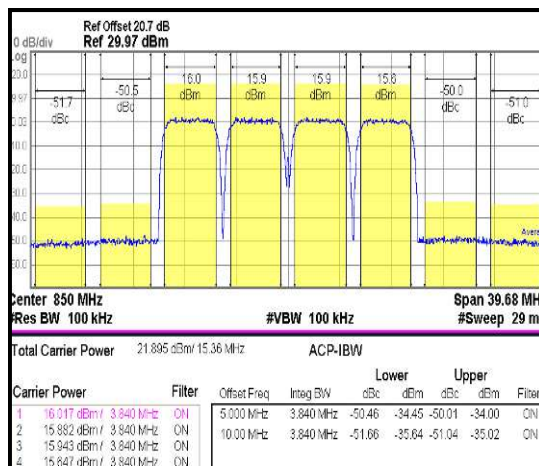

3GPP WCDMA TM1 +64DPCH 4FA

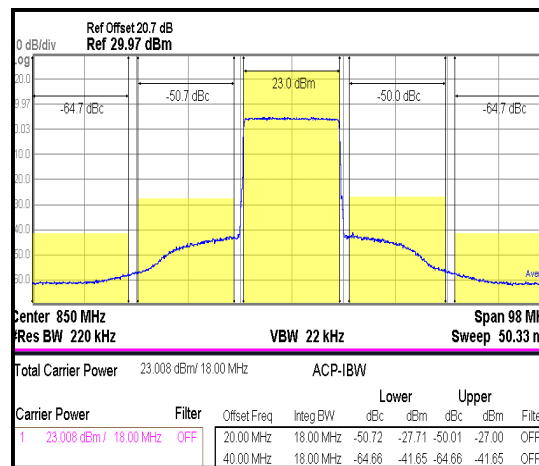

3GPP LTE E-TM3.1 20MHz

Application Circuit: 1750 MHz

Schematic Diagram	BOM	Marks		
	C1	1206	N/A	
	C2	0603	1nF	
	C3	0603	1nF	
	C4	0603	N/A	
	C5	0603	1nF	
	C6	0603	2pF	
	C7	0603	0 Ω	±5%
	C8	0603	3.3pF	
	C9	0603	2.7pF	
	C10	0603	4.3pF	High Q
	C11	0603	3.9pF	
	C12	0603	1uF	
	C13	0603	100pF	
	C14	0603	1nF	
	C15	1206	10uF	Tantalum
L1	0603	N/A		
L2	0603	12nH		
L3	1008	22nH	Coil	
R1	0603	100 Ω	±5%	
R2	0603	270 Ω	±5%	

PCB Diagram	Notice																								
	<p>Below information is subject to change as conditions of the substrate.</p> <table border="1"> <thead> <tr> <th>Reference</th> <th>Object</th> <th>Distance</th> </tr> </thead> <tbody> <tr> <td>Input pin</td> <td>C8</td> <td>5.5mm</td> </tr> <tr> <td>Input pin</td> <td>C9</td> <td>4.4mm</td> </tr> <tr> <td>Output pin</td> <td>C10</td> <td>2.8mm</td> </tr> <tr> <td>Pin 16</td> <td>C3</td> <td>7.2mm</td> </tr> <tr> <td>Pin 16</td> <td>C6</td> <td>2.0mm</td> </tr> <tr> <td>Pin 19</td> <td>C5</td> <td>1.0mm</td> </tr> <tr> <td>Pin 20</td> <td>C2</td> <td>10.6mm</td> </tr> </tbody> </table> <p>1. Pin 16 & 20 is used for Vce of the inner bias circuit. To eliminate bias line resonance you need above 10mm transmission line and adjust the position of C2, C3, C4, C5 and C6. Also you can adjust spectrum regrowth about bandwidth of signals which you want.</p> <p>2. C10 : We recommend High-Q capacitor for better output power performance. In this document we used '4.3pF(251R14S4R3BV4, EIA 0603) of Johanson Technology.</p>	Reference	Object	Distance	Input pin	C8	5.5mm	Input pin	C9	4.4mm	Output pin	C10	2.8mm	Pin 16	C3	7.2mm	Pin 16	C6	2.0mm	Pin 19	C5	1.0mm	Pin 20	C2	10.6mm
	Reference	Object	Distance																						
Input pin	C8	5.5mm																							
Input pin	C9	4.4mm																							
Output pin	C10	2.8mm																							
Pin 16	C3	7.2mm																							
Pin 16	C6	2.0mm																							
Pin 19	C5	1.0mm																							
Pin 20	C2	10.6mm																							

Typical Performance

(V_{CC} & V_{Bias} = +5V, I_{cq} = 680mA, T_a = 25°C)

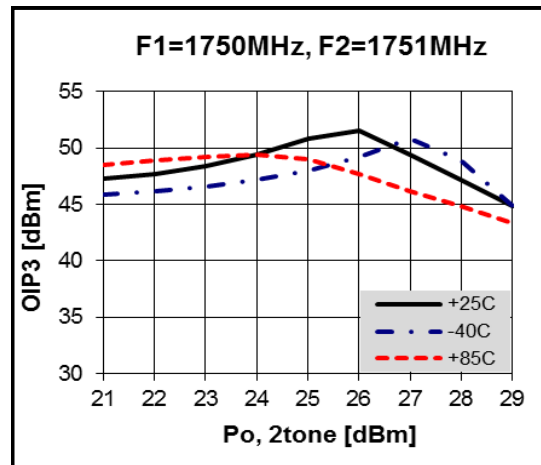
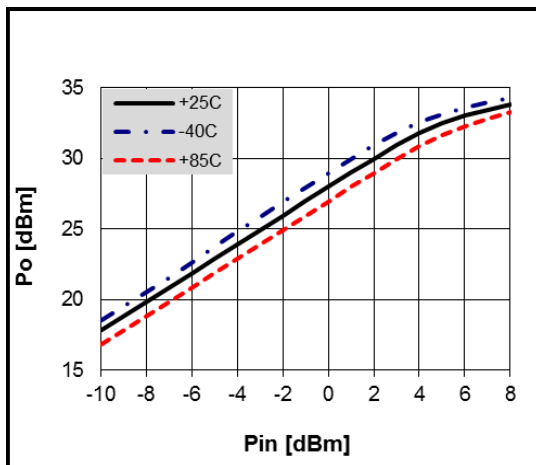
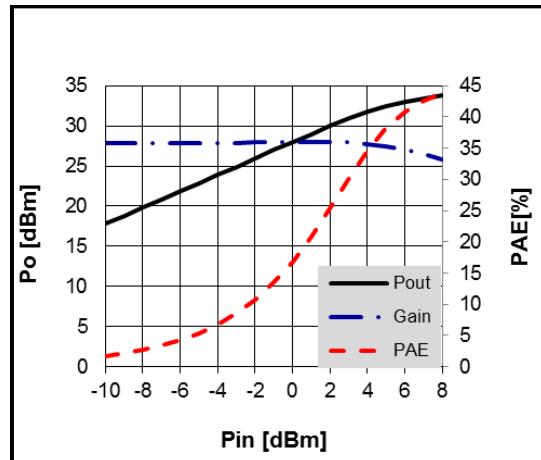
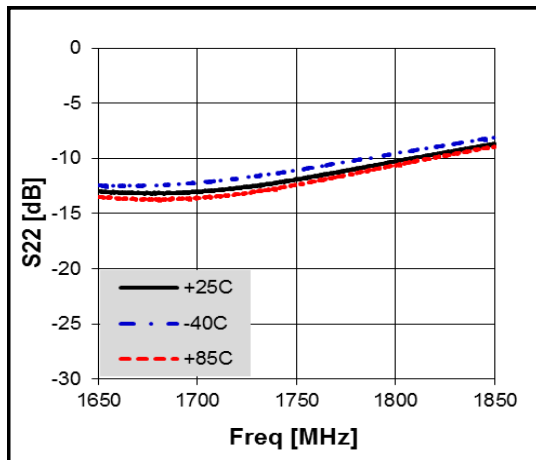
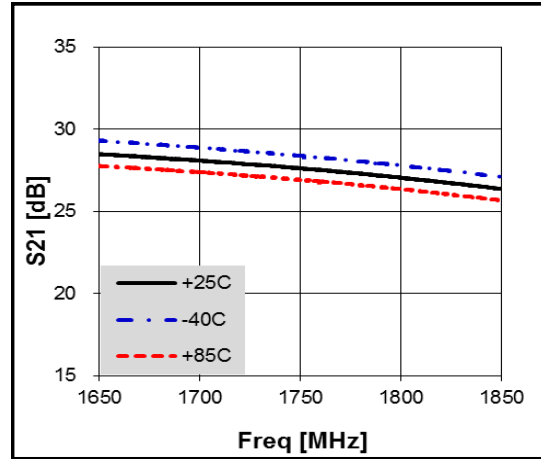
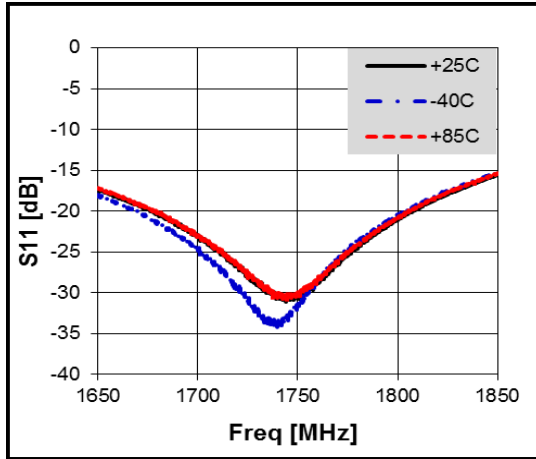

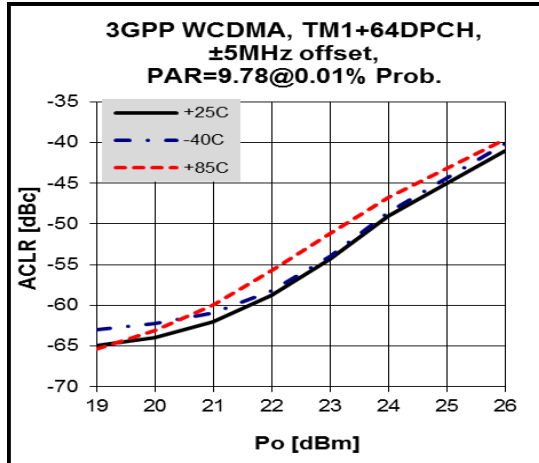
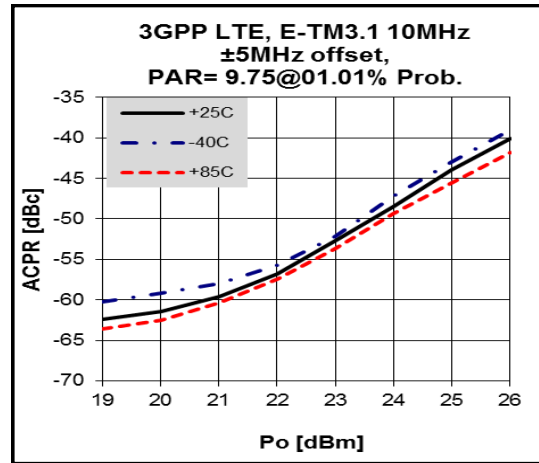
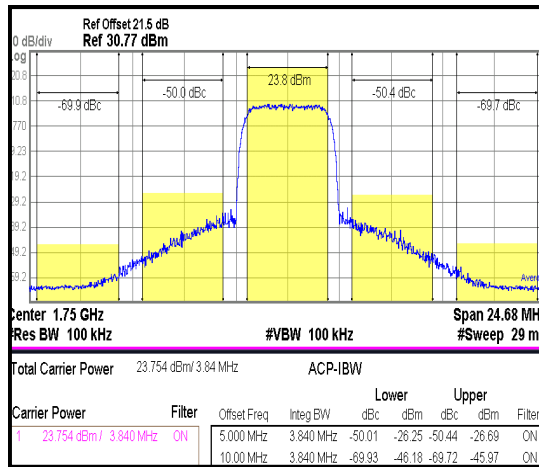
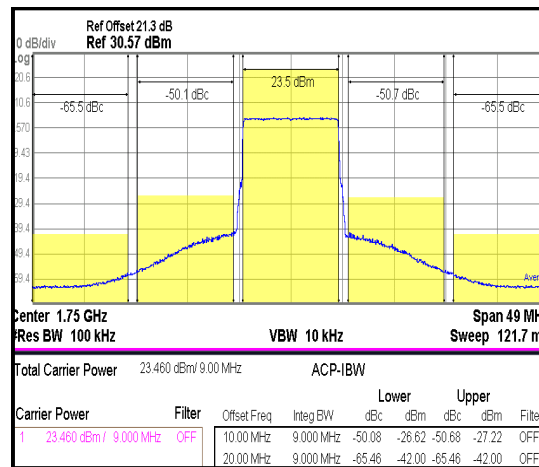
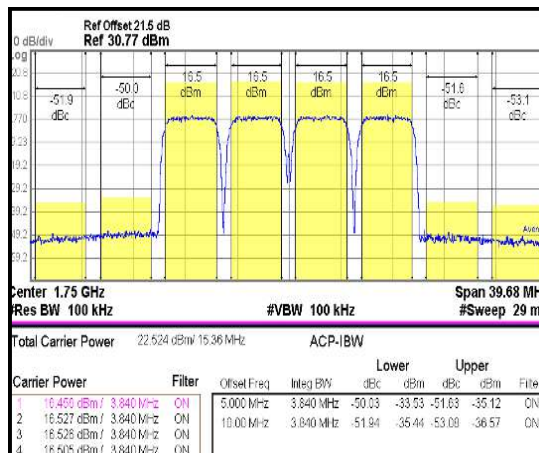
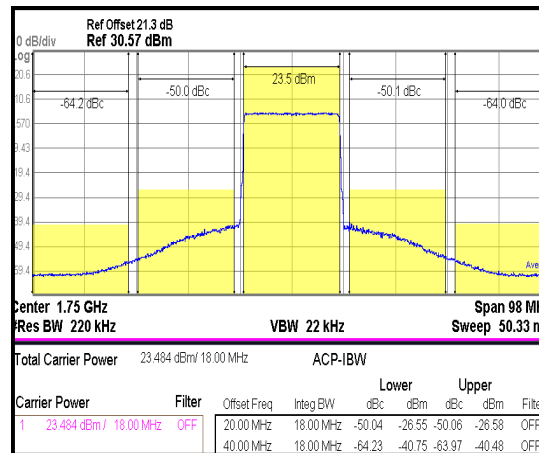
700-2400 MHz 2W High Linearity 5V 2-Stage Power Amplifier

3GPP WCDMA TM1 +64DPCH 1FA

3GPP LTE E-TM3.1 10MHz

3GPP WCDMA TM1 +64DPCH 4FA

3GPP LTE E-TM3.1 20MHz

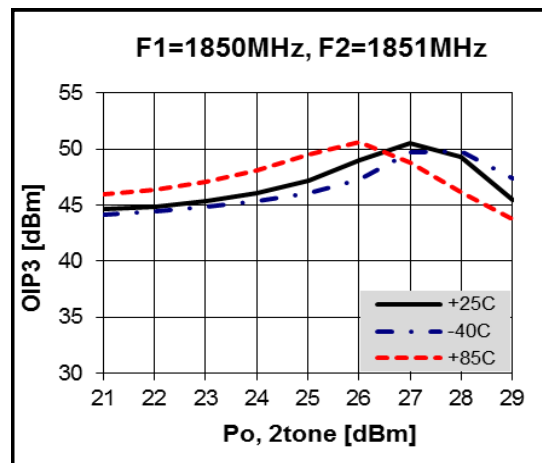
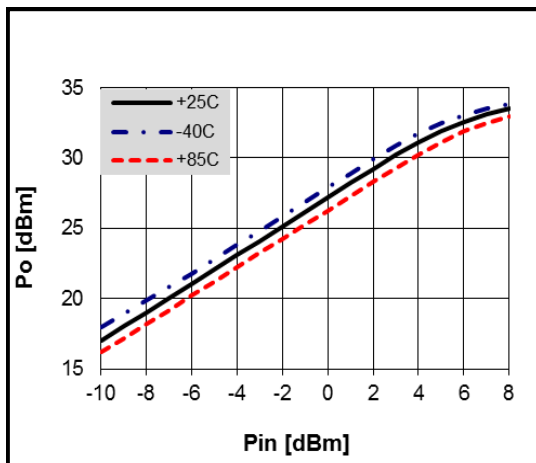
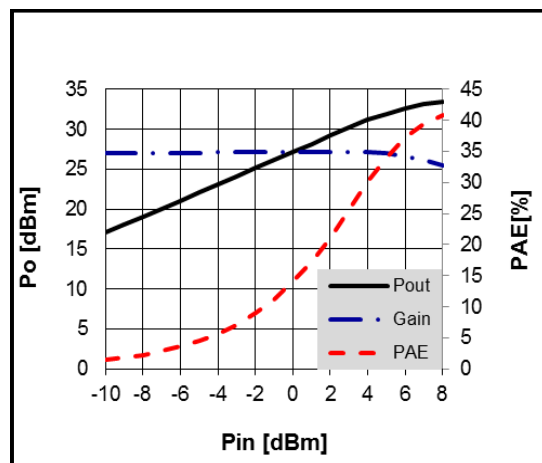
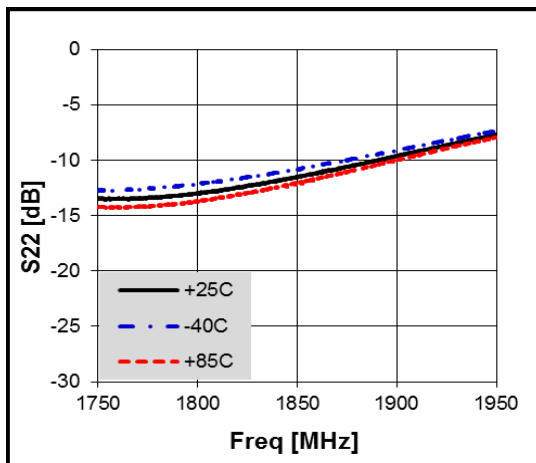
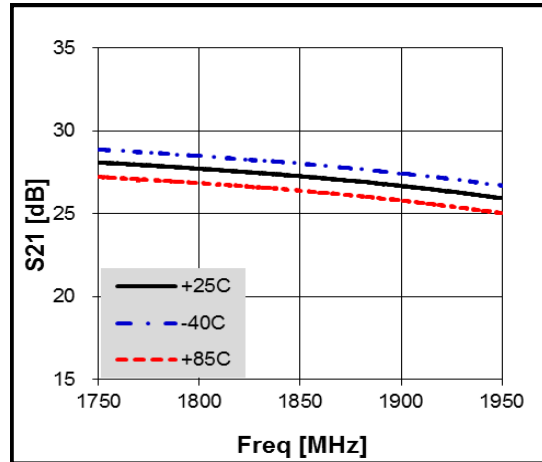
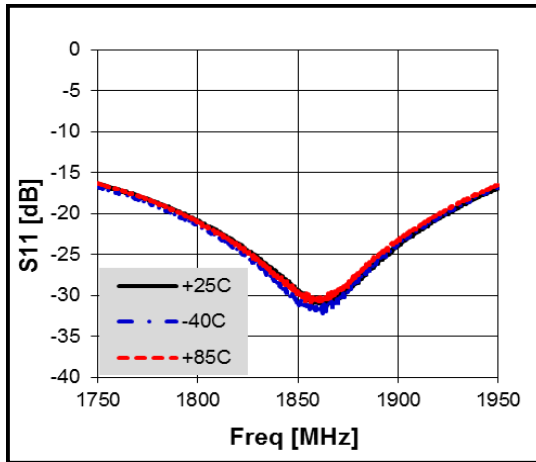
3GPP WCDMA TM1 +64DPCH 4FA

3GPP LTE E-TM3.1 20MHz

Application Circuit: 1850 MHz

Schematic Diagram	BOM	Marks		
	C1	1206	N/A	
	C2	0603	1nF	
	C3	0603	1nF	
	C4	0603	N/A	
	C5	0603	1nF	
	C6	0603	3pF	
	C7	0603	0 Ω	±5%
	C8	0603	3.3pF	
	C9	0603	2.7pF	
	C10	0603	4.3pF	High Q
	C11	0603	3.9pF	
	C12	0603	1uF	
	C13	0603	100pF	
	C14	0603	1nF	
	C15	1206	10uF	Tantalum
L1	0603	N/A		
L2	0603	12nH		
L3	1008	12nH	Coil	
R1	0603	100 Ω	±5%	
R2	0603	270 Ω	±5%	

PCB Diagram	Notice																								
	<p>Below information is subject to change as conditions of the substrate.</p> <table border="1"> <thead> <tr> <th>Reference</th> <th>Object</th> <th>Distance</th> </tr> </thead> <tbody> <tr> <td>Input pin</td> <td>C8</td> <td>5.0mm</td> </tr> <tr> <td>Input pin</td> <td>C9</td> <td>3.5mm</td> </tr> <tr> <td>Output pin</td> <td>C10</td> <td>2.5mm</td> </tr> <tr> <td>Pin 16</td> <td>C3</td> <td>5.5mm</td> </tr> <tr> <td>Pin 16</td> <td>C6</td> <td>2.0mm</td> </tr> <tr> <td>Pin 19</td> <td>C5</td> <td>1.0mm</td> </tr> <tr> <td>Pin 20</td> <td>C2</td> <td>10.6mm</td> </tr> </tbody> </table> <p>1. Pin 16 & 20 is used for Vce of the inner bias circuit. To eliminate bias line resonance you need above 10mm transmission line and adjust the position of C2, C3, C4, C5 and C6. Also you can adjust spectrum regrowth about bandwidth of signals which you want.</p> <p>2. C10 : We recommend High-Q capacitor for better output power performance. In this document we used '4.3pF(251R14S4R3BV4, EIA 0603) of Johanson Technology.</p> <p>3. C7 : Non-critical 0 Ω.</p>	Reference	Object	Distance	Input pin	C8	5.0mm	Input pin	C9	3.5mm	Output pin	C10	2.5mm	Pin 16	C3	5.5mm	Pin 16	C6	2.0mm	Pin 19	C5	1.0mm	Pin 20	C2	10.6mm
	Reference	Object	Distance																						
Input pin	C8	5.0mm																							
Input pin	C9	3.5mm																							
Output pin	C10	2.5mm																							
Pin 16	C3	5.5mm																							
Pin 16	C6	2.0mm																							
Pin 19	C5	1.0mm																							
Pin 20	C2	10.6mm																							

Typical Performance
 (V_{CC} & V_{Bias} = +5V, I_{CQ} = 680mA, T_a = 25°C)



700-2400 MHz 2W High Linearity 5V 2-Stage Power Amplifier

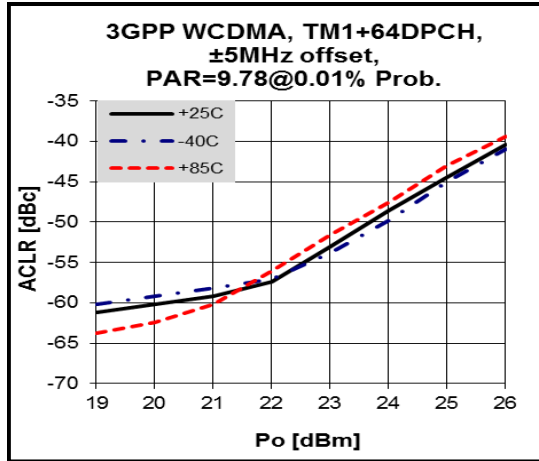

3GPP WCDMA TM1 +64DPCH 1FA

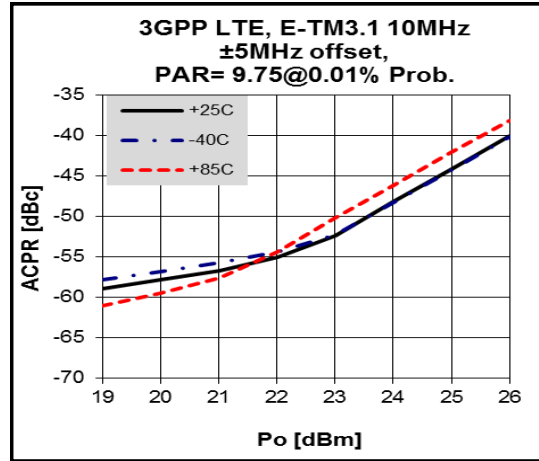

3GPP LTE E-TM3.1 10MHz

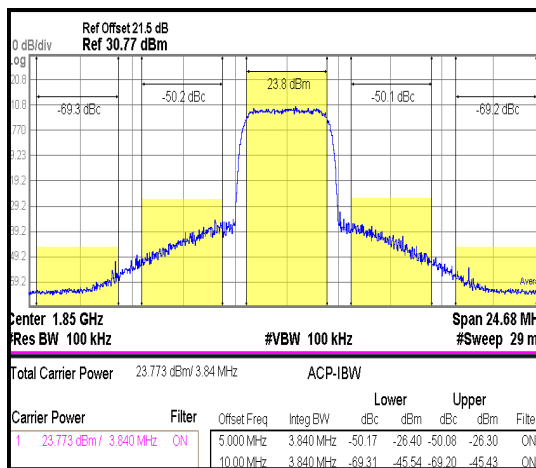

3GPP WCDMA TM1 +64DPCH 4FA

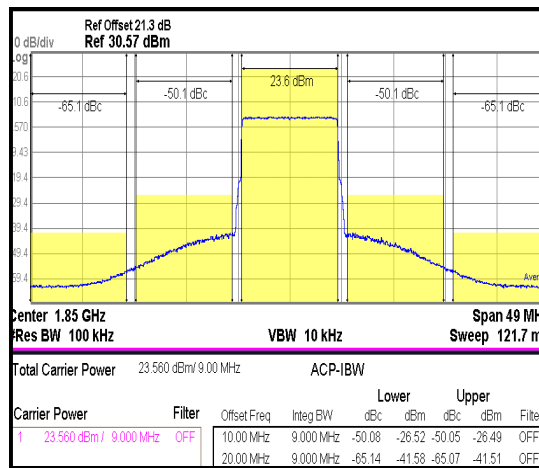

3GPP LTE E-TM3.1 20MHz

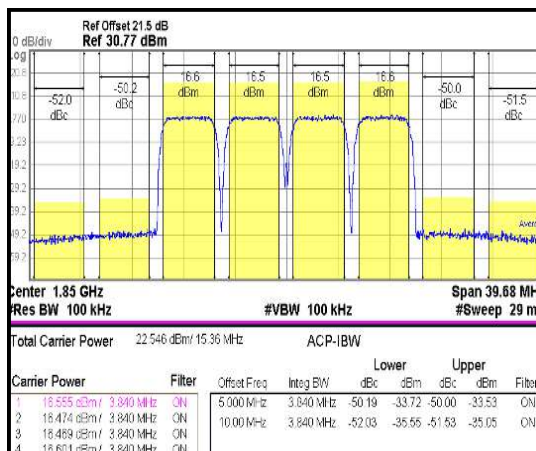

3GPP WCDMA TM1 +64DPCH 4FA

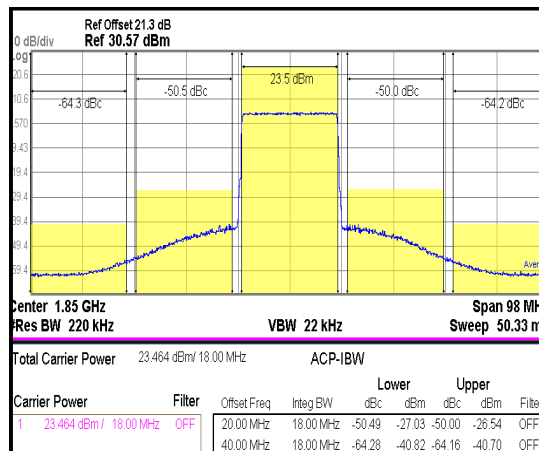

3GPP LTE E-TM3.1 20MHz

Application Circuit: 1960 MHz

Schematic Diagram	BOM	Marks		
	C1	1206	N/A	
	C2	0603	1nF	
	C3	0603	1nF	
	C4	0603	N/A	
	C5	0603	1nF	
	C6	0603	2pF	
	C7	0603	0 Ω	±5%
	C8	0603	3.3pF	
	C9	0603	2.7pF	
	C10	0603	4.3pF	High Q
	C11	0603	3.9pF	
	C12	0603	1uF	
	C13	0603	100pF	
	C14	0603	1nF	
	C15	1206	10uF	Tantalum
L1	0603	N/A		
L2	0603	12nH		
L3	1008	12nH	Coil	
R1	0603	100 Ω	±5%	
R2	0603	270 Ω	±5%	

PCB Diagram	Notice																								
	<p>Below information is subject to change as conditions of the substrate.</p> <table border="1"> <thead> <tr> <th>Reference</th> <th>Object</th> <th>Distance</th> </tr> </thead> <tbody> <tr> <td>Input pin</td> <td>C8</td> <td>5.0mm</td> </tr> <tr> <td>Input pin</td> <td>C9</td> <td>3.1mm</td> </tr> <tr> <td>Output pin</td> <td>C10</td> <td>2.0mm</td> </tr> <tr> <td>Pin 16</td> <td>C3</td> <td>5.0mm</td> </tr> <tr> <td>Pin 16</td> <td>C6</td> <td>2.0mm</td> </tr> <tr> <td>Pin 19</td> <td>C5</td> <td>1.0mm</td> </tr> <tr> <td>Pin 20</td> <td>C2</td> <td>10.6mm</td> </tr> </tbody> </table>	Reference	Object	Distance	Input pin	C8	5.0mm	Input pin	C9	3.1mm	Output pin	C10	2.0mm	Pin 16	C3	5.0mm	Pin 16	C6	2.0mm	Pin 19	C5	1.0mm	Pin 20	C2	10.6mm
	Reference	Object	Distance																						
Input pin	C8	5.0mm																							
Input pin	C9	3.1mm																							
Output pin	C10	2.0mm																							
Pin 16	C3	5.0mm																							
Pin 16	C6	2.0mm																							
Pin 19	C5	1.0mm																							
Pin 20	C2	10.6mm																							
	<ol style="list-style-type: none"> Pin 16 & 20 is used for Vce of the inner bias circuit. To eliminate bias line resonance you need above 10mm transmission line and adjust the position of C2, C3, C4, C5 and C6. Also you can adjust spectrum regrowth about bandwidth of signals which you want. C10 : We recommend High-Q capacitor for better output power performance. In this document we used '4.3pF(251R14S4R3BV4, EIA 0603) of Johanson Technology. C7 : Non-critical 0 Ω. 																								

Typical Performance
 (V_{CC} & V_{Bias} = +5V, I_{cq} = 680mA, T_a = 25°C)

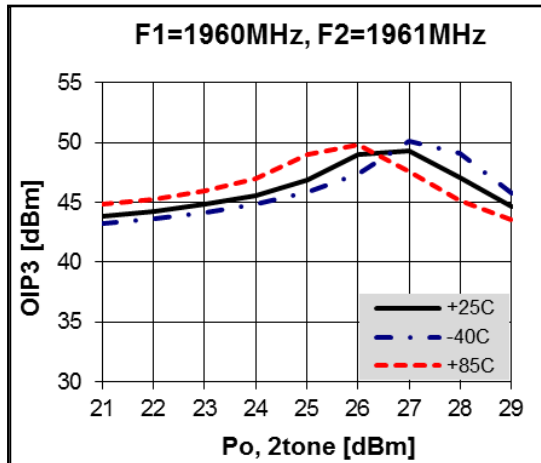
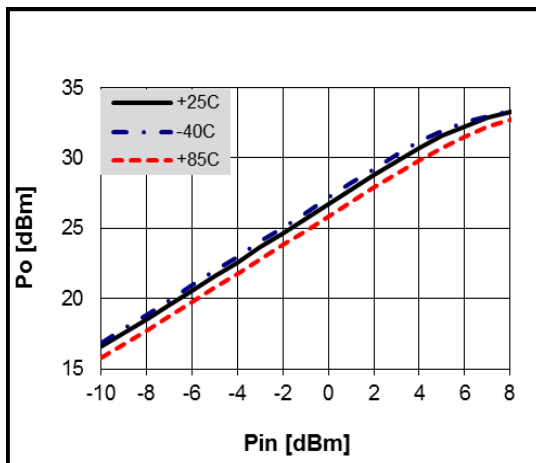
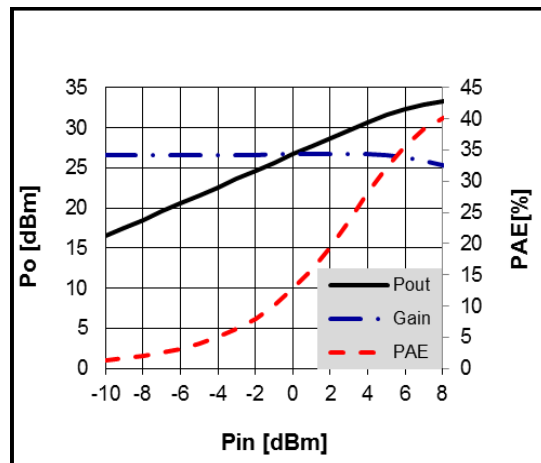
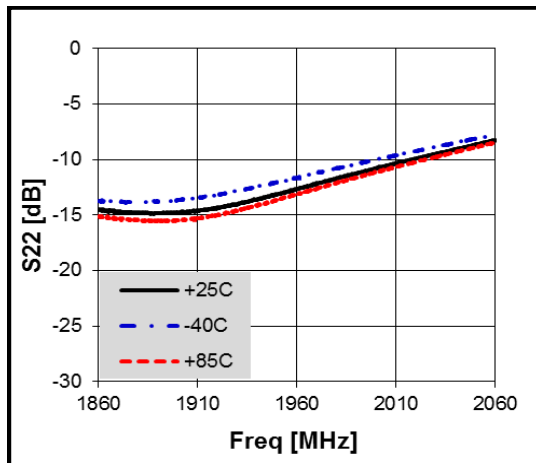
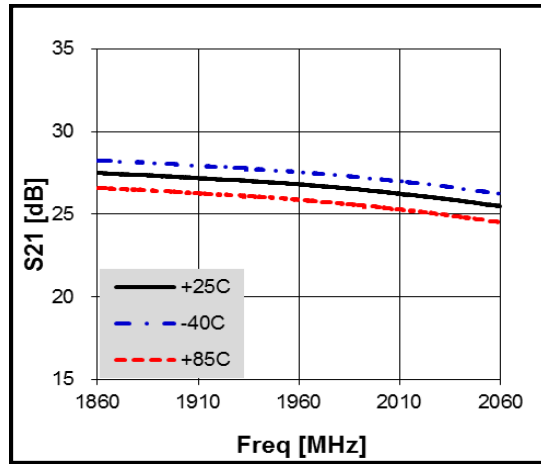
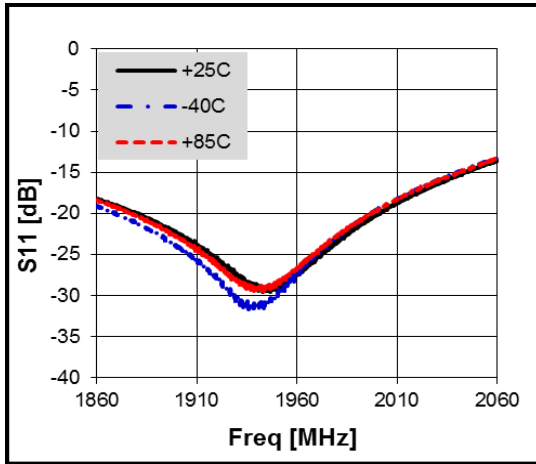

700-2400 MHz 2W High Linearity 5V 2-Stage Power Amplifier

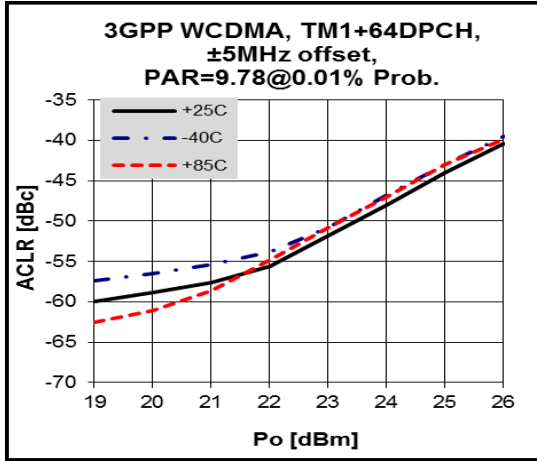

3GPP WCDMA TM1 +64DPCH 1FA

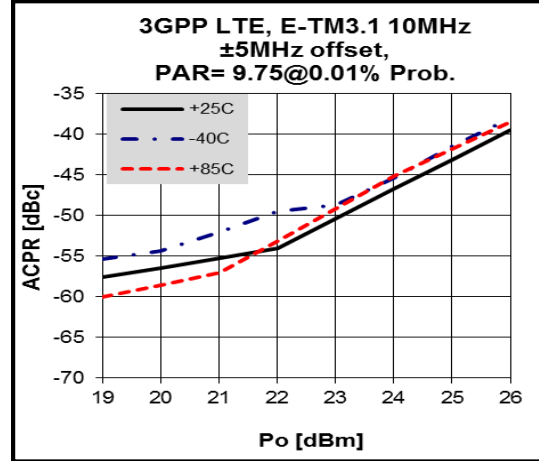

3GPP LTE E-TM3.1 10MHz

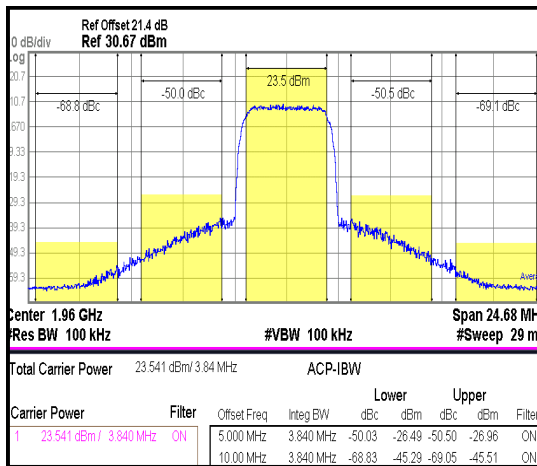

3GPP WCDMA TM1 +64DPCH 4FA

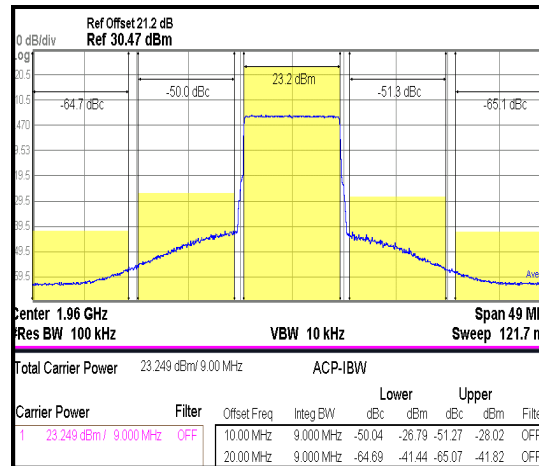

3GPP LTE E-TM3.1 20MHz

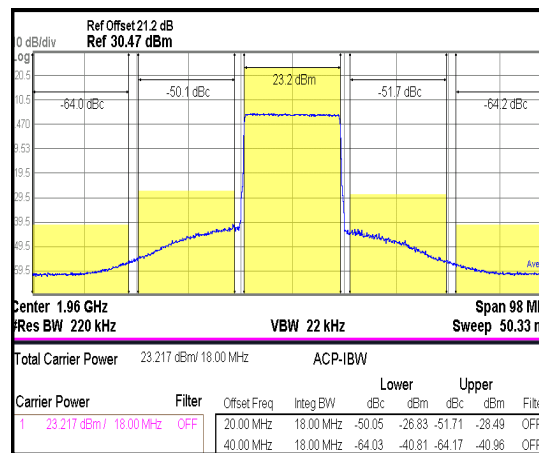
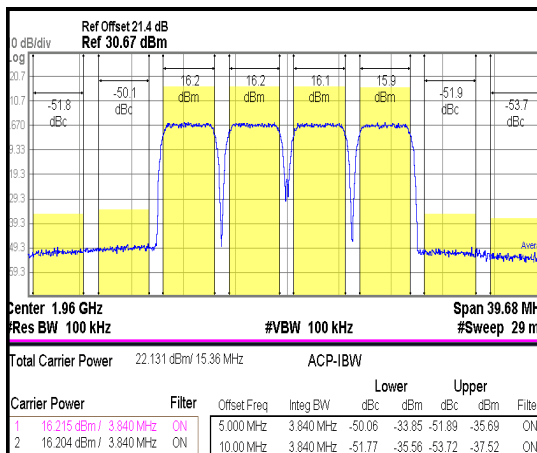

Application Circuit: 2140 MHz

Schematic Diagram	BOM	Marks	
	C1	1206 10uF	Tantalum
	C2	0603 N/A	
	C3	0603 1nF	
	C4	0603 1nF	
	C5	0603 1nF	
	C6	0603 3pF	
	C7	0603 0 Ω	±5%
	C8	0603 3pF	
	C9	0603 2.7pF	
	C10	0603 3.9pF	High Q
	C11	0603 4.3pF	
	C12	0603 1uF	
	C13	0603 100pF	
	C14	0603 1nF	
	C15	1206 10uF	Tantalum
L1	0603 N/A		
L2	0603 12nH		
L3	1008 10nH	Coil	
R1	0603 100 Ω	±5%	
R2	0603 270 Ω	±5%	

PCB Diagram	Notice																								
<p>BeRex 131126 2140MHz</p> <p>BMT332 EV Board Ver 1.0 Size = 39.3 X 29.5 mm Copper = 1oz.</p> <p>R04003C Er = 3.55 Thk. = 12 mil Width = 0.646 mm Clearance = 0.366 mm</p>	<p>Below information is subject to change as conditions of the substrate.</p> <table border="1"> <thead> <tr> <th>Reference</th> <th>Object</th> <th>Distance</th> </tr> </thead> <tbody> <tr> <td>Input pin</td> <td>C8</td> <td>4.1mm</td> </tr> <tr> <td>Input pin</td> <td>C9</td> <td>2.2mm</td> </tr> <tr> <td>Output pin</td> <td>C10</td> <td>1.8mm</td> </tr> <tr> <td>Pin 16</td> <td>C3</td> <td>3.0mm</td> </tr> <tr> <td>Pin 16</td> <td>C6</td> <td>2.0mm</td> </tr> <tr> <td>Pin 19</td> <td>C5</td> <td>1.0mm</td> </tr> <tr> <td>Pin 20</td> <td>C4</td> <td>5.0mm</td> </tr> </tbody> </table> <p>1. Pin 16 & 20 is used for Vce of the inner bias circuit. To eliminate bias line resonance you need above 10mm transmission line and adjust the position of C2, C3, C4, C5 and C6. Also you can adjust spectrum regrowth about bandwidth of signals which you want.</p> <p>2. C10 : We recommend High-Q capacitor for better output power performance. In this document we used '3.9pF(251R14S3R9BV4, EIA 0603) of Johanson Technology.</p> <p>3. C7 : Non-critical 0 Ω.</p>	Reference	Object	Distance	Input pin	C8	4.1mm	Input pin	C9	2.2mm	Output pin	C10	1.8mm	Pin 16	C3	3.0mm	Pin 16	C6	2.0mm	Pin 19	C5	1.0mm	Pin 20	C4	5.0mm
	Reference	Object	Distance																						
	Input pin	C8	4.1mm																						
	Input pin	C9	2.2mm																						
	Output pin	C10	1.8mm																						
	Pin 16	C3	3.0mm																						
	Pin 16	C6	2.0mm																						
	Pin 19	C5	1.0mm																						
	Pin 20	C4	5.0mm																						

Typical Performance
 (V_{CC} & V_{Bias} = +5V, I_{CQ} = 680mA, T_a = 25°C)

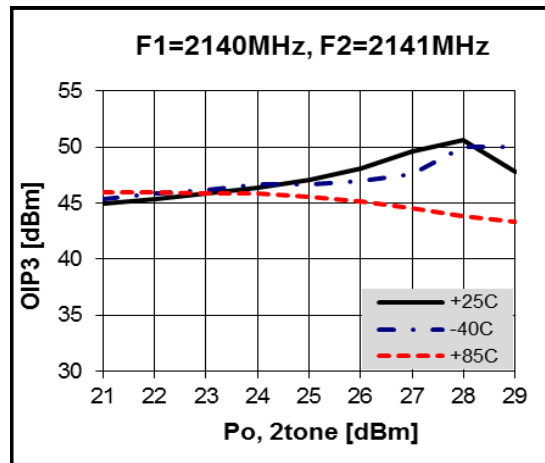
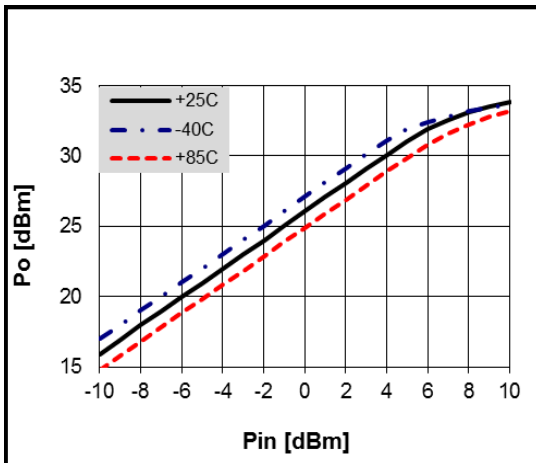
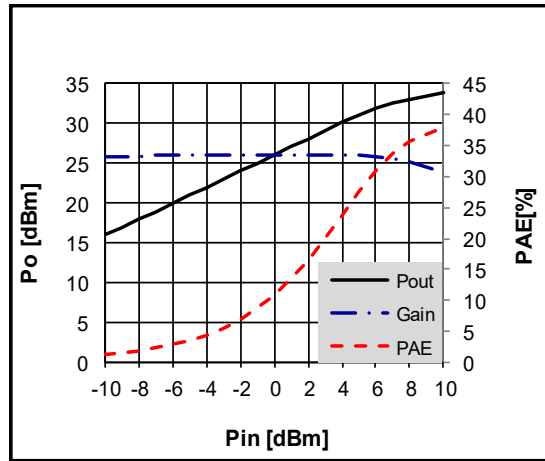
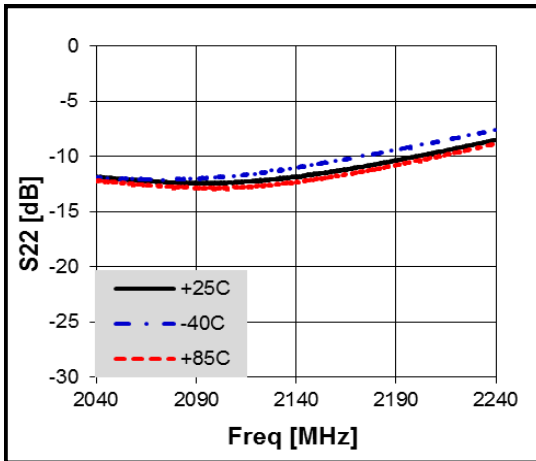
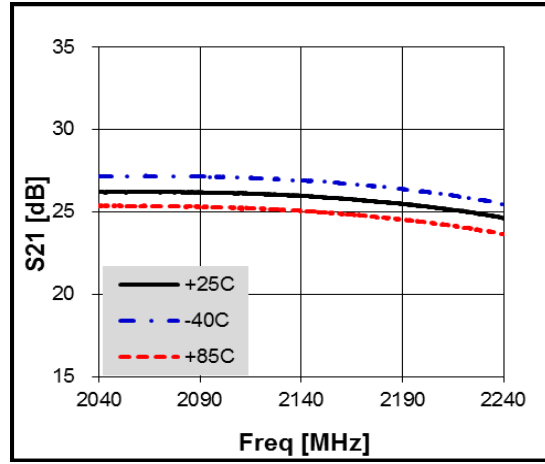
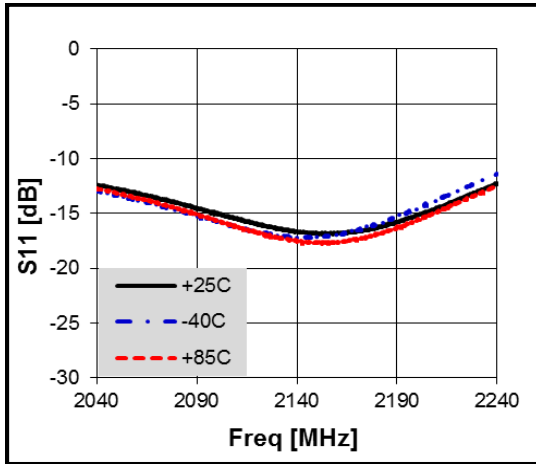

700-2400 MHz 2W High Linearity 5V 2-Stage Power Amplifier

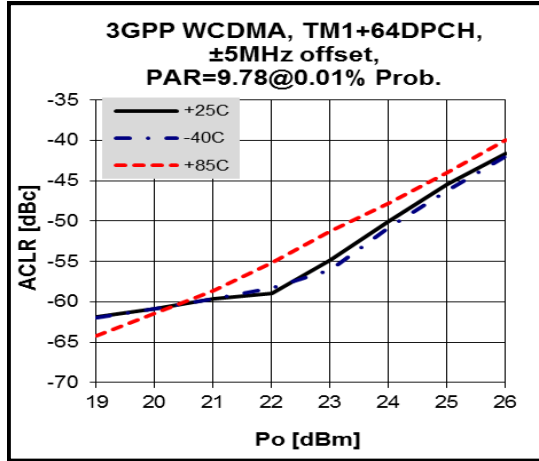

3GPP WCDMA TM1 +64DPCH 1FA

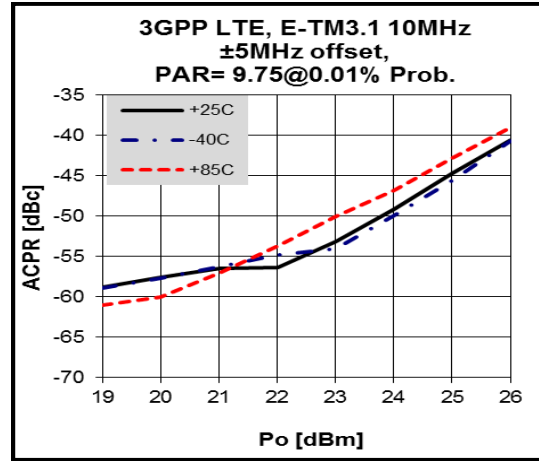

3GPP LTE E-TM3.1 10MHz

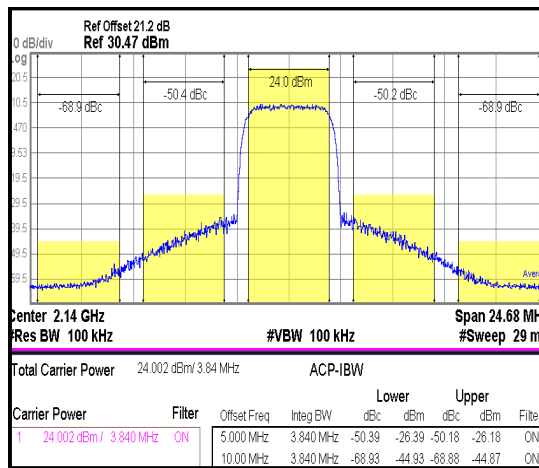

3GPP WCDMA TM1 +64DPCH 4FA

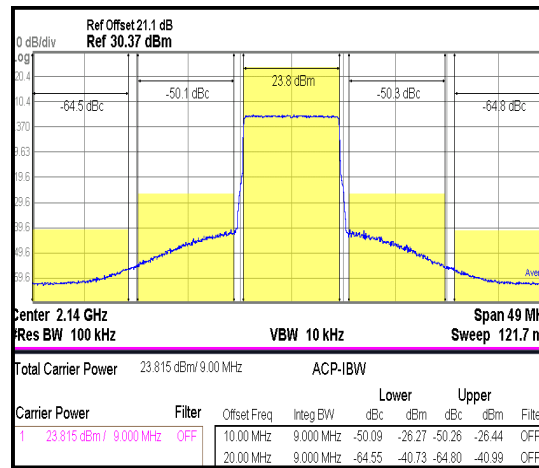

3GPP LTE E-TM3.1 20MHz

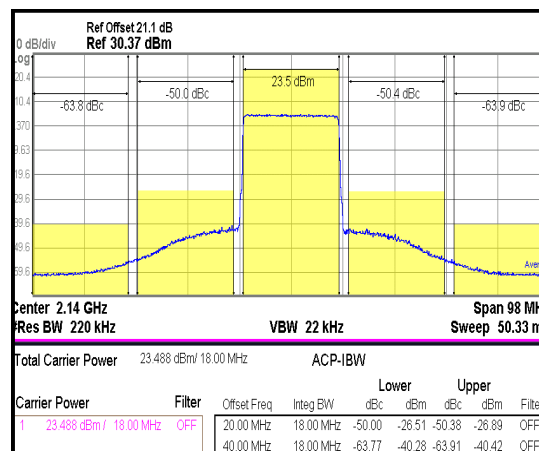
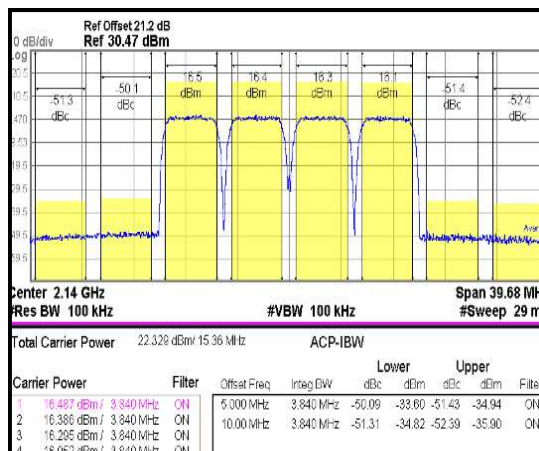

Application Circuit: 2350 MHz

Schematic Diagram	BOM	Marks		
	C1	1206	10uF	Tantalum
	C2	0603	N/A	
	C3	0603	N/A	
	C4	0603	0.75pF	
	C5	0603	1nF	
	C6	0603	1nF	
	C7	0603	0 Ω	±5%
	C8	0603	2.2pF	
	C9	0603	2.7pF	
	C10	0603	3.3pF	High Q
	C11	0603	22pF	
	C12	0603	1uF	
	C13	0603	100pF	
	C14	0603	1nF	
	C15	1206	10uF	Tantalum
L1	0603	N/A		
L2	0603	15nH		
L3	1008	10nH	Coil	
R1	0603	100 Ω	±5%	
R2	0603	270 Ω	±5%	

PCB Diagram	Notice																					
	<p>Below information is subject to change as conditions of the substrate.</p> <table border="1"> <thead> <tr> <th>Reference</th> <th>Object</th> <th>Distance</th> </tr> </thead> <tbody> <tr> <td>Input pin</td> <td>C8</td> <td>3.6mm</td> </tr> <tr> <td>Input pin</td> <td>C9</td> <td>0.6mm</td> </tr> <tr> <td>Output pin</td> <td>C10</td> <td>1.3mm</td> </tr> <tr> <td>Pin 16</td> <td>C6</td> <td>2.0mm</td> </tr> <tr> <td>Pin 19</td> <td>C5</td> <td>1.0mm</td> </tr> <tr> <td>Pin 20</td> <td>C4</td> <td>5.0mm</td> </tr> </tbody> </table> <p>1. Pin 16 & 20 is used for Vce of the inner bias circuit. To eliminate bias line resonance you need above 10mm transmission line and adjust the position of C2, C3, C4, C5 and C6. Also you can adjust spectrum regrowth about bandwidth of signals which you want.</p> <p>2. C10 : We recommend High-Q capacitor for better output power performance. In this document we used '3.3pF(251R14S3R3BV4, EIA 0603) of Johanson Technology.</p> <p>3. C7 : Non-critical 0 Ω.</p>	Reference	Object	Distance	Input pin	C8	3.6mm	Input pin	C9	0.6mm	Output pin	C10	1.3mm	Pin 16	C6	2.0mm	Pin 19	C5	1.0mm	Pin 20	C4	5.0mm
	Reference	Object	Distance																			
Input pin	C8	3.6mm																				
Input pin	C9	0.6mm																				
Output pin	C10	1.3mm																				
Pin 16	C6	2.0mm																				
Pin 19	C5	1.0mm																				
Pin 20	C4	5.0mm																				

Typical Performance
 (V_{CC} & V_{Bias} = +5V, I_{CQ} = 680mA, T_a = 25°C)

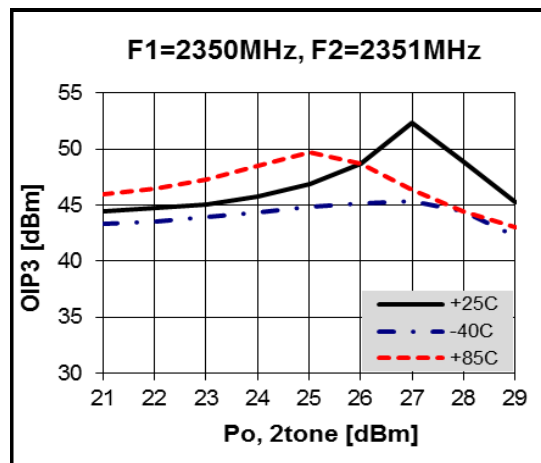
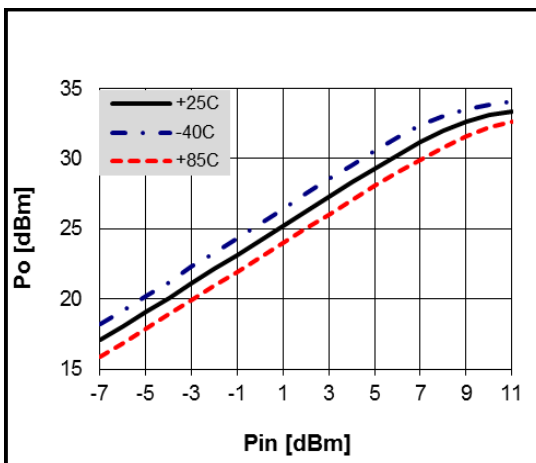
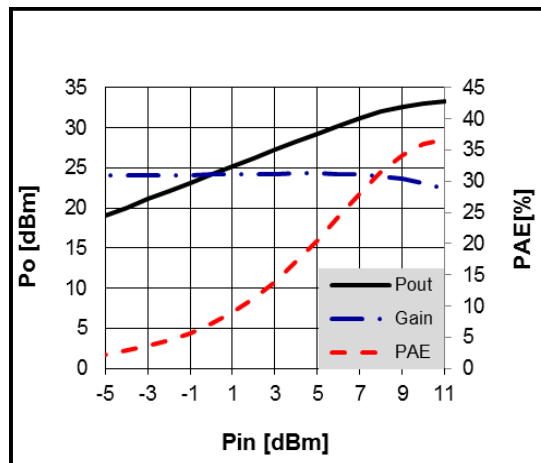
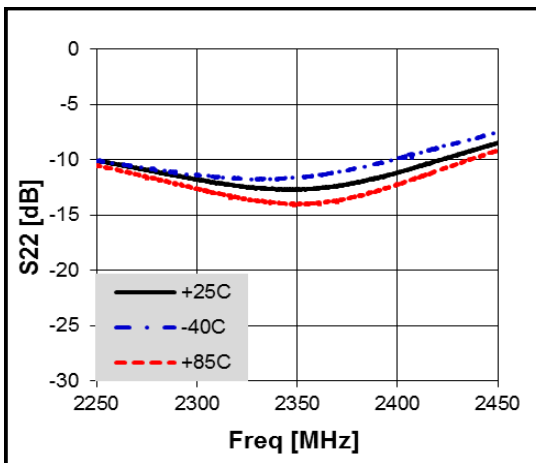
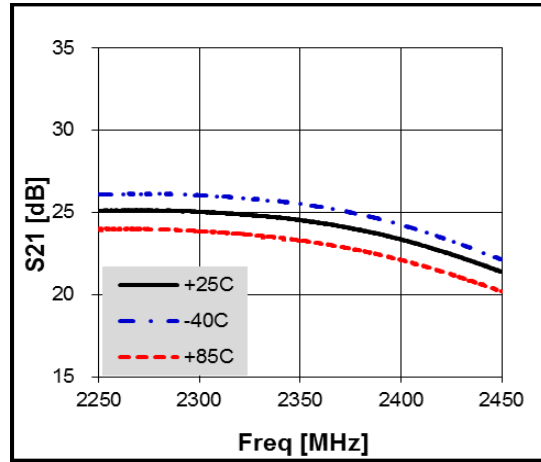
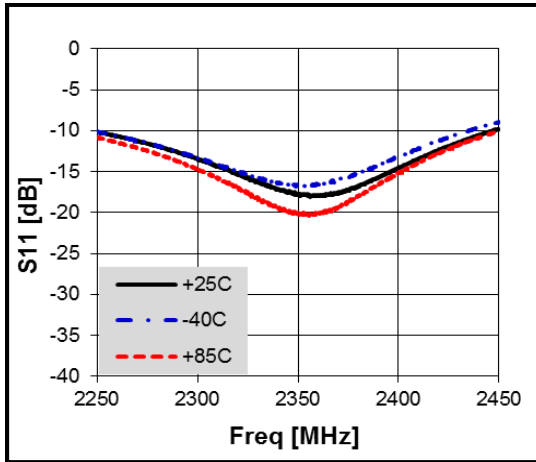

700-2400 MHz 2W High Linearity 5V 2-Stage Power Amplifier

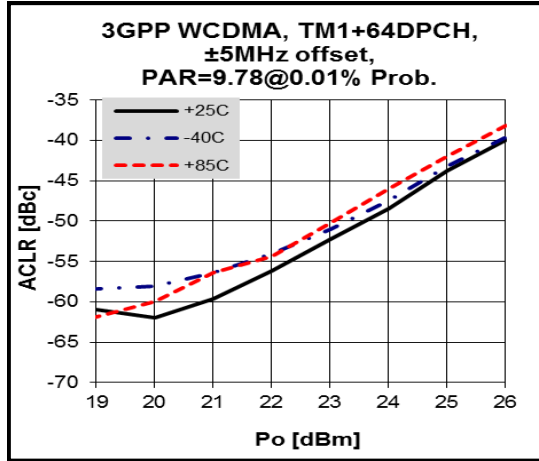

3GPP WCDMA TM1 +64DPCH 1FA

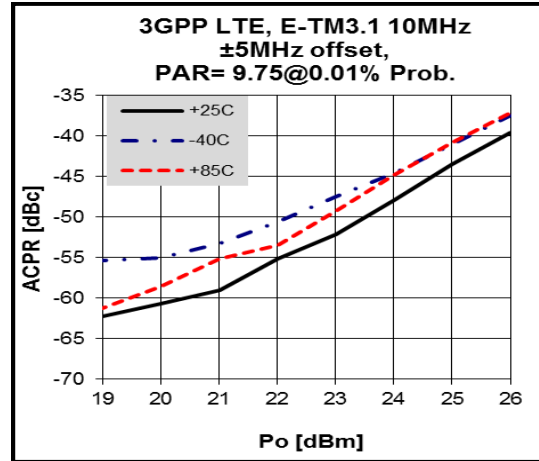

3GPP LTE E-TM3.1 10MHz

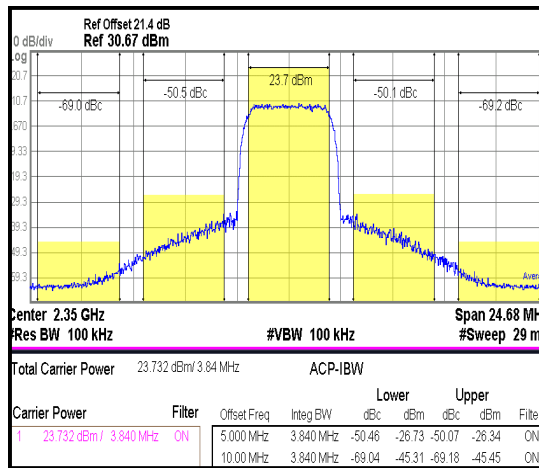

3GPP WCDMA TM1 +64DPCH 4FA

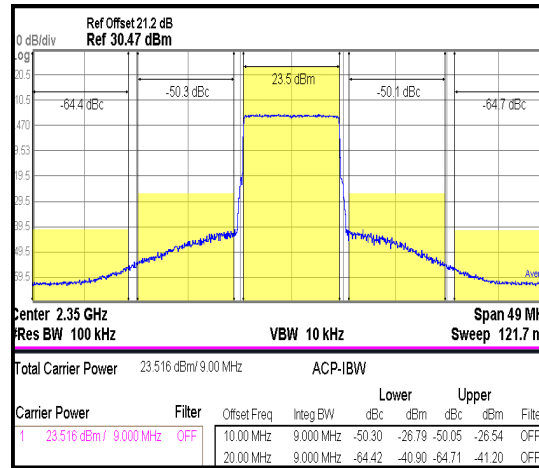

3GPP LTE E-TM3.1 20MHz

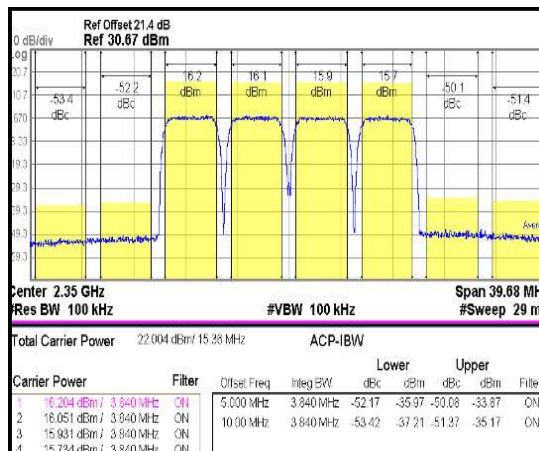

3GPP WCDMA TM1 +64DPCH 4FA

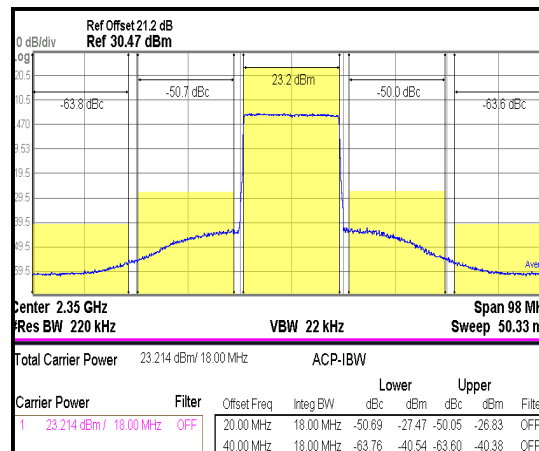

3GPP LTE E-TM3.1 20MHz

Typical Performance (Pout vs. Icc)

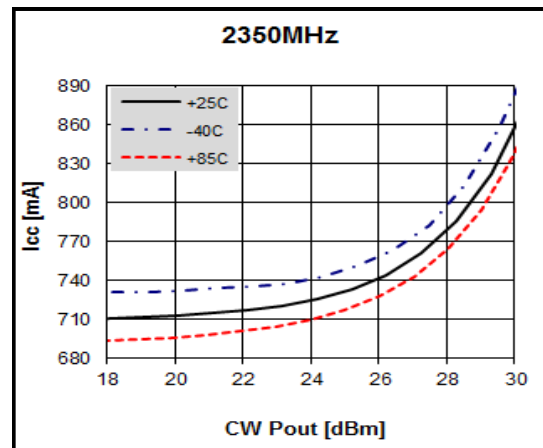
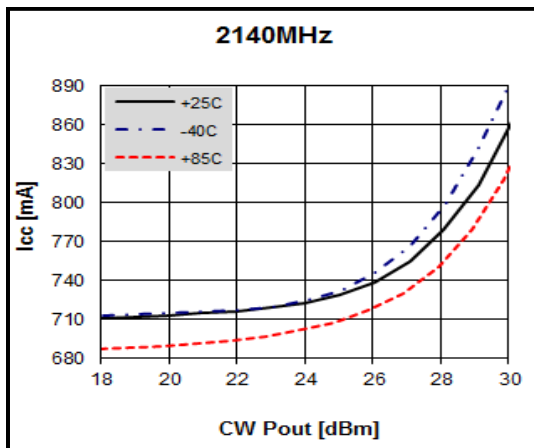
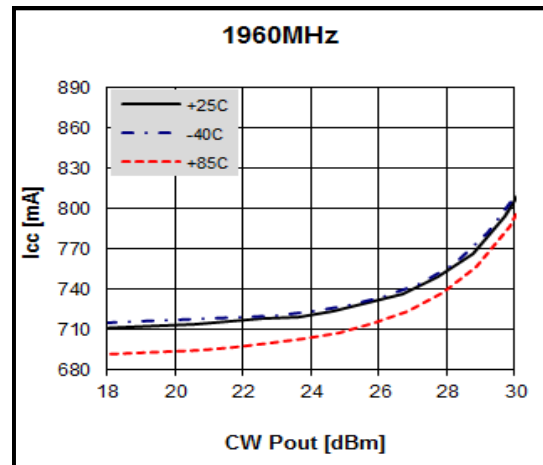
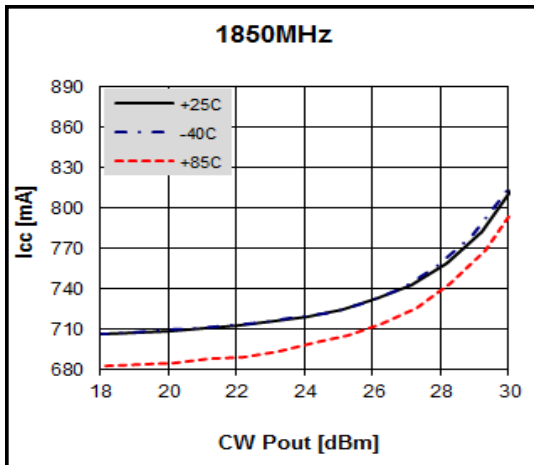
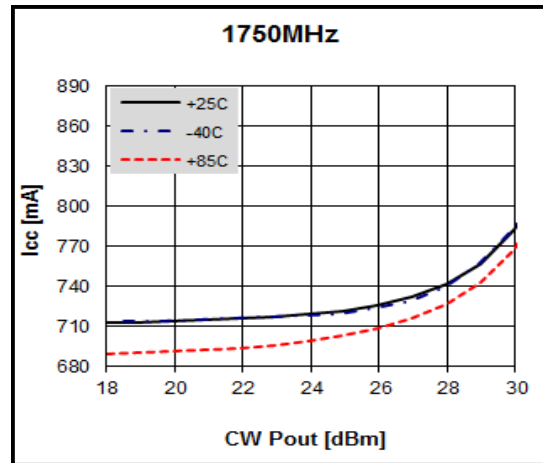
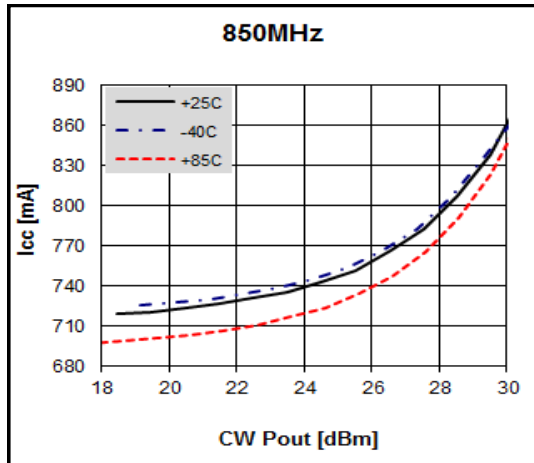
 (V_{CC} & V_{Bias} = +5V, I_{CQ} = 680mA, T_a = 25°C)

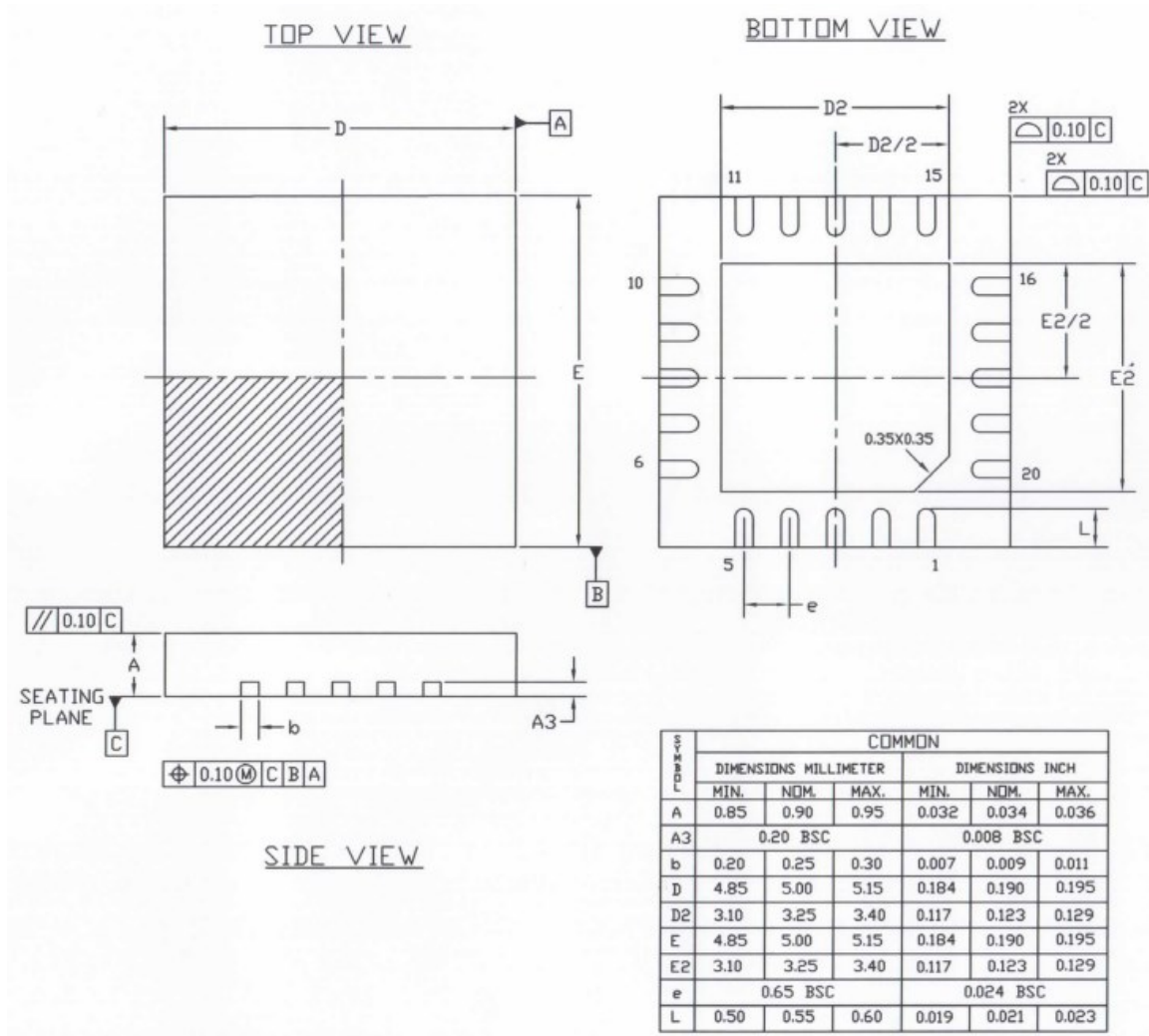
Package Outline Dimension

NOTES :

1. DIMENSION AND TOLERANCING CONFORM TO ASME Y14.5M-1994.
2. CONTROLLING DIMENSIONS : MILLIMETER. CONVERTED INCH DIMENSION ARE NOT NECESSARILY EXACT.
3. DIMENSION b APPLIES TO METALLIZED TERMINAL AND IS MEASURED BETWEEN 0.15 AND 0.30 MM. FROM TERMINAL TIP.
4. INSULATION THICKNESS, CLEARANCE OF OVERLAP ARE USER DEFINED.
5. INSULATION NOT COMPLETELY SHOWN FOR REASONS OF CLARITY.

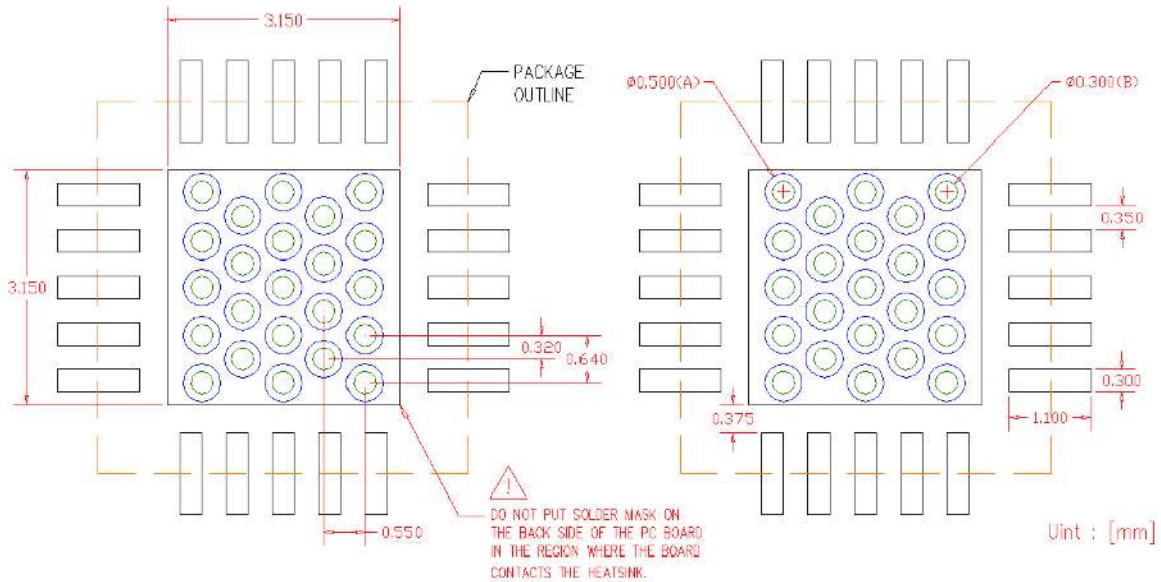
Suggested PCB Land Pattern and PAD Layout



• Notes

1. Use 1 oz. copper minimum for top and bottom layer metal.
2. A heatsink underneath the area of the PCB for the mounted device is required for proper thermal operation.
3. Ground / thermal vias are critical for the proper performance of this device.

Package Marking

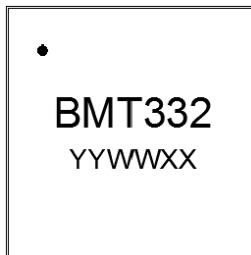

YY = Year, WW = Working Week,
XX = Wafer No.

PCB Mounting

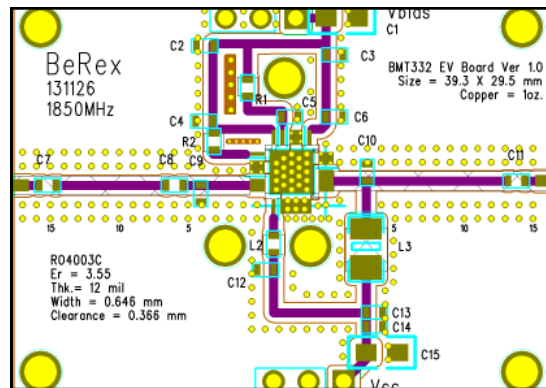

Tape & Reel

QFN 5x5

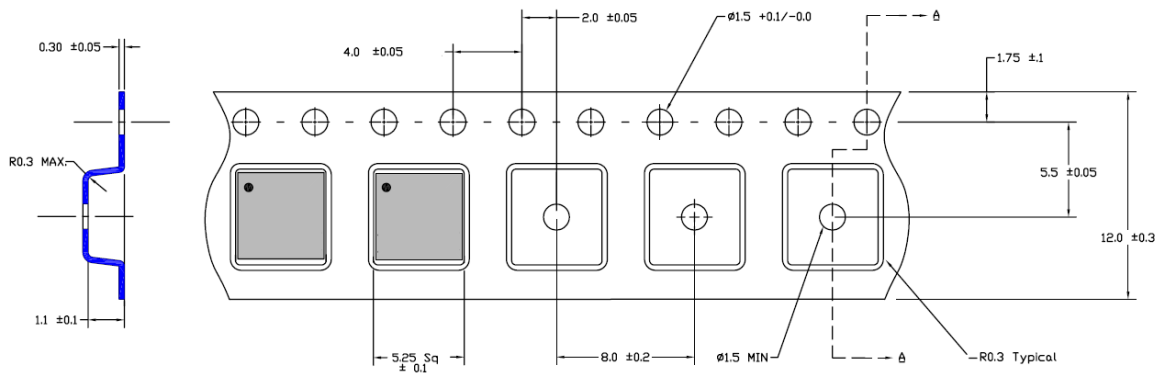

Packaging information :

Tape width(mm) : 12

Reel Size (inches) : 7

Device Cavity Pitch(mm) : 8

Devices Per Reel : 1000

Lead plating finish

100% Tin Matte finish

(All BeRex products undergoes a 1 hour, 150 degree C, Anneal bake to eliminate thin whisker growth concerns.)

MSL / ESD Rating

ESD Rating: Class 1C
Value: Passes $\geq 1000V$ to $< 2000 V$
Test: Human Body Model (HBM)
Standard: JEDEC Standard JS-001-2012

ESD Rating: Class C3
Value: Passes $>1000V$
Test: Charged Device Model (CDM)
Standard: JEDEC Standard JESD22-C101F

MSL Rating: Level 1 at $+260^{\circ}C$ convection reflow
Standard: JEDEC Standard J-STD-020



Proper ESD procedures should be followed when handling this device.

RoHS Compliance

This part is compliant with Restrictions on the Use of Certain Hazardous Substances in Electrical and Electronic Equipment (RoHS) Directive 2011/65/EU as amended by Directive 2015/863/EU.

This product also is compliant with a concentration of the Substances of Very High Concern (SVHC) candidate list which are contained in a quantity of less than 0.1%(w/w) in each components of a product and/or its packaging placed on the European Community market by the BeRex and Suppliers.

NATO CAGE code:

2	N	9	6	F
---	---	---	---	---