

DRAWING MADE IN THIRD ANGLE PROJECTION

PART NUMBER	REV	FIRST USED	FEED TYPE
567429-1	B	LEADMAKER	MECH
567429-2	B	AMP-O-LECTRIC	MECH

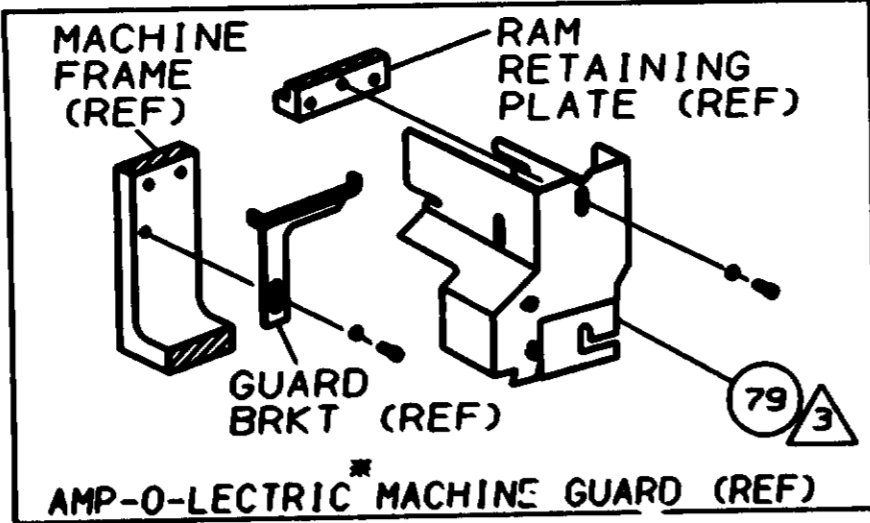
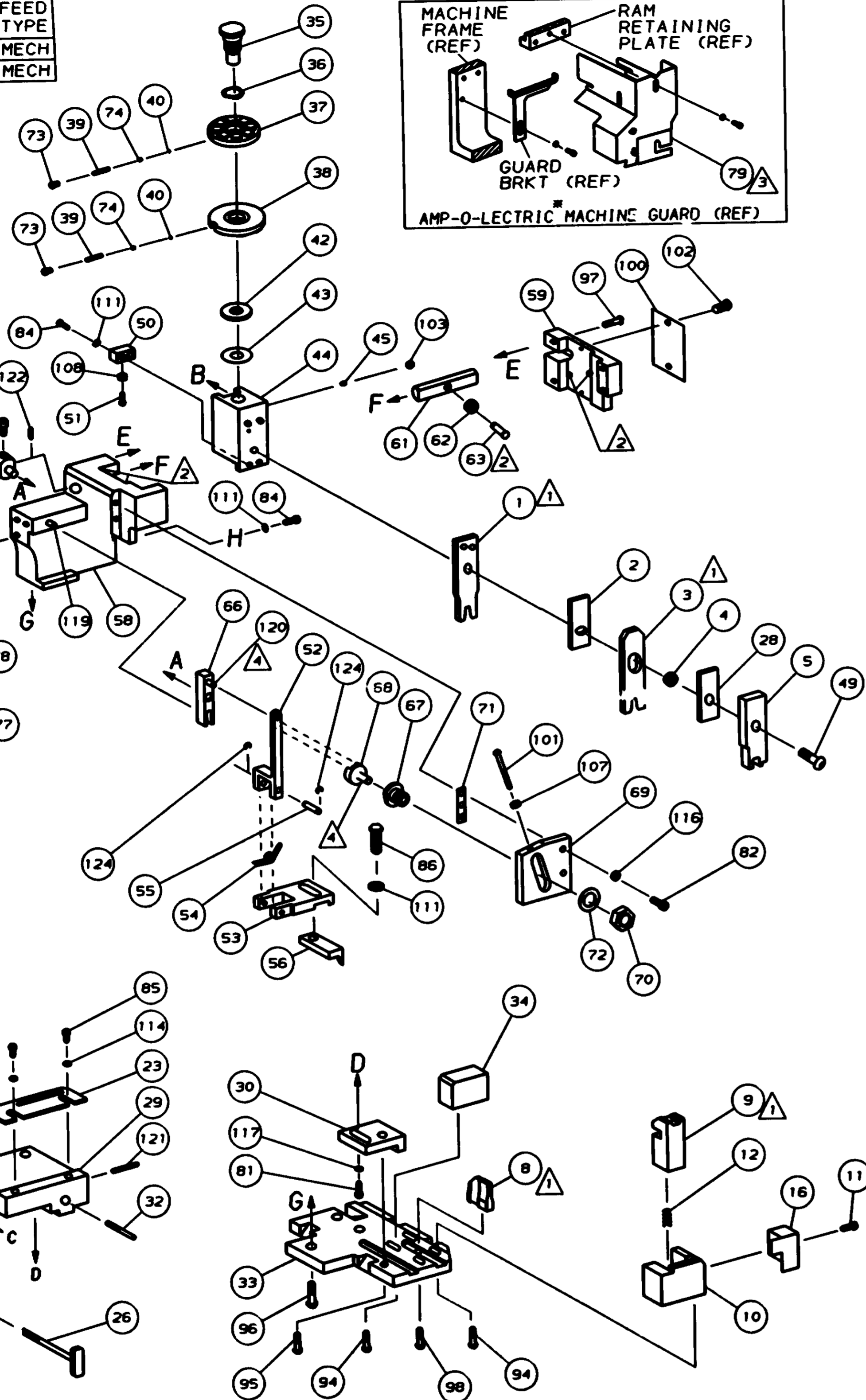
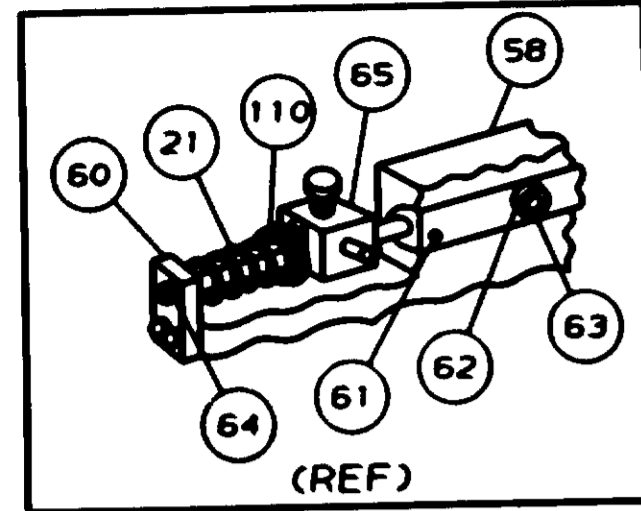

- 1 RECOMMENDED SPARE PARTS.
- 2 GREASE LIGHTLY.
- 3 GUARD MUST BE IN PLACE WHEN OPERATING APPLICATOR IN AMP-O-LECTRIC MACHINE.
- 4 LUBRICATE DAILY USING NO. 20 MACHINE OIL.
- 5. ITEMS WITH QTY OF REF SPECIFIED (EXCEPT ITEM 79) ARE USED ON ITEM 46.

REF	REF	-	A	21045-3	RING, RET "C" (#.187) FD FING PIN	124
1	1	-	A	5-21028-1	PIN, SLT SPR (#.125x.50) ADJ ROD	122
1	1	-	A	4-21028-0	PIN, SLT SPR (#.093x.75) ST GDE PL	121
REF	REF	-	A	1-21030-1	PIN, DOWEL (#.187x.50) LEVER	120
REF	REF	-	A	1-21030-6	PIN, DOWEL (#.187x.1.25) HOUSING	119
1	1	-	A	21024-5	WASHER, LOCK (#10) ADJ BLOCK	117
REF	REF	-	A	21024-5	WASHER, LOCK (#10) ADJ PLATE	116
REF	REF	-	A	21024-5	WASHER, LOCK (#10) FEED GDE ROD	115
2	2	-	A	21024-2	WASHER, LOCK (#4) FRONT STP GUIDE	114
1	1	-	A	21024-4	WASHER, LOCK (#8) STRIPPER	111
REF	REF	-	A	21899-4	WASHER, FLAT (#5/16) SCREW ADJ	110
1	REF	-	A	21899-2	WASHER, FLAT (NO.10) LUB ASSY	109
1	1	-	A	21018-5	NUT, HEX (NO. 6) HOLDDOWN	108
REF	REF	-	A	21018-5	NUT, HEX (6-32) FEED ADJ	107
1	1	-	A	456567-1	SCR, SHLD (#.188x.12) STRIP	104
1	1	-	A	21009-2	SCR, SKT SET (1/4-20x.25 LW) RAM	103
2	2	-	A	21017-2	SCR, DRIVE (#2x.19) ID PLATE	102
REF	REF	-	A	6-23715-5	SCR, PAN HD (6-32x.1.50) FEED ADJ	101
1	1	-	B	461264-1	PLATE, IDENTIFICATION	100
2	2	-	A	2-21002-9	SCR, BHC (10-32x.75) DRAG	99
1	1	-	A	22733-8	SCR, BHC (8-32x.38 LW) ANVIL	98
REF	REF	-	A	2-21002-9	SCR, BHC (10-32x.75) CAP	97
REF	REF	-	A	2-22733-8	SCR, BHC (1/4-20x.62) HOUSING	96
REF	REF	-	A	2-21002-7	SCR, BHC (10-32x.50) SG ADJ BLOCK	95
2	4	-	A	2-21002-2	SCR, BHC (8-32x.50) SHEAR	94
2	2	-	A	2-21002-1	SCR, BHC (8-32x.38) R STRIP GUIDE	93
1	1	-	A	1-21002-7	SCR, BHC (6-32x.38) CAM	91
1	1	-	A	2-22603-0	SCR, HEX HD (8-32x.31) FEED FINGER	86
2	2	-	A	1-21000-3	SCR, SHC (4-40x.25) F ST GUIDE	85
3	3	-	A	2-21000-7	SCR, SHC (8-32x.50) STRIPPER	84
REF	REF	-	A	3-21000-7	SCR, SHC (10-32x.75) FEED ROD GD	83
REF	REF	-	A	3-21000-6	SCR, SHC (10-32x.62) FD ADJ BLK	82
2	1	-	A	3-21000-4	SCR, SHC (10-32x.38) SG ADJ BLK	81
REF	REF	-	A	3-21000-4	SCR, SHC (10-32x.38) PIVOT BLK	80
REF	-	-	B	455749-1	GUARD, WINDOW	79
1	REF	-	C	1-465184-0	LUBRICATOR ASSY	78
REF	REF	-	A	22014-1	OIL, LUBRICATING	77
1	1	-	A	690603-1	SPRING, ASSIST	74
2	2	-	A	23030-1	SCR, SHC (6-32x.25) CP DISC	73
REF	REF	-	A	458109-1	WASHER, SPECIAL	72
REF	REF	-	A	690517-1	SPACER	71
2	2	-	A	690603-1	SPRING, ASSIST	74
2	2	-	A	23030-1	SCR, SHC (6-32x.25) CP DISC	73
REF	REF	-	A	458109-1	WASHER, SPECIAL	72
REF	REF	-	A	690517-1	SPACER	71

REF	REF	-	B	22594-8	NUT, HEX (1/2-20)	70
REF	REF	-	B	240628-1	PLATE, ADJUSTMENT	69
REF	REF	-	B	240626-1	SHAFT, PIVOT	68
REF	REF	-	B	240633-1	BUSHING	67
REF	REF	-	A	455680-1	LEVER, INTERMEDIATE	66
REF	REF	-	B	240629-1	BLOCK, PIVOT	65
REF	REF	-	A	240632-2	SCREW, ADJ FEED ROD	64
REF	REF	-	B	240659-3	PIN, CAM ROLLER	63
REF	REF	-	B	240658-1	ROLLER, CAM	62
REF	REF	-	B	454398-2	ROD, FEED	61
REF	REF	-	A	454178-1	GUIDE, FEED ROD	60
REF	REF	-	C	454220-1	CAP, RAM	59
REF	REF	-	D	454485-1	HOUSING	58
1	1	-	B	690542-2	PAWL, FEED	56
REF	REF	-	B	240624-1	PIN, FEED FINGER	55
REF	REF	-	B	691499-1	SPRING, FEED FINGER	54
REF	REF	-	B	690541-1	FINGER, FEED	53
REF	REF	-	A	455679-1	LEVER, TERMINAL FEED ARM	52
1	1	-	A	811242-2	BUMPER, HOLDDOWN	51
1	1	-	A	690753-1	SPACER, TONKER	50
1	1	-	A	7-21002-9	BOLT, CRIMPER (5/16x1.00)	49
1	-	-	B	690602-5	CAM, PRE-FEED 1/8 ST	48
-	1	-	B	690501-4	CAM, POST-FEED 1/8 ST	47
1	1	-	B	459456-1	APPLICATOR, BASIC (SUBASSY)	46
1	1	-	A	690191-1	PLUG, NYLON	45
1	1	-	C	455673-1	RAM	44
1	1	-	A	690125-1	WASHER, LAMINATED	43
1	1	-	A	690124-1	WASHER, RAM	42
2	2	-	A	23241-6	BALL, STEEL	40
2	2	-	A	690170-1	SPRING, COMPRESSION	39
1	1	-	C	690142-1	DISC, INSULATION	38
1	1	-	B	8-455829-7	DISC, WIRE	37
1	1	-	A	22480-5	WASHER, SPRING	36
1	1	-	B	690212-1	POST, RAM	35
1	1	-	B	690786-1	SUPPORT, TERMINAL	34
REF	REF	-	D	455675-1	PLATE, BASE	33
1	1	-	A	690432-3	SCREW, ADJUSTMENT	32
REF	REF	-	B	455689-1	BLOCK, STRIP GUIDE ADJ	30
1	1	-	C	455671-1	PLATE, STRIP GUIDE	29
1	1	-	C	455888-4	SPACER, FRONT SHEAR DEP	28
2	2	-	A	1-22284-0	SPRING, DRAG	27
1	1	-	B	690546-1	LEVER, DRAG RELEASE	26
1	1	-	B	240792-1	DRAG, TERMINAL	25
1	1	-	D	6-690504-3	GUIDE, STRIP (REAR)	24
1	1	-	A	690438-1	GUIDE, STRIP (FRONT)	23
-	1	-	B	690472-2	STRIPPER	22
REF	REF	-	A	4-22284-9	SPRING, FEED RETURN	21
1	-	-	B	458950-1	STRIPPER, WIRE STOP	20
1	-	-	B	458949-1	STRIPPER	19
1	1	-	B	691667-1	GUARD, CHIP (FRONT)	16
1	1	-	B	354091-1	DEPRESSOR, SHEAR (FRONT)	5
1	1	-	B	238011-7	SPACER, BLOCK CRIMPER	4
1	1	-	C	3-683453-7	CRIMPER, INSULATION	3
1	1	-	C	1-455888-4	SPACER, CRIMPER	2
1	1	-	C	2-456401-0	CRIMPER, WIRE	1

* Trademark of AMP Incorporated

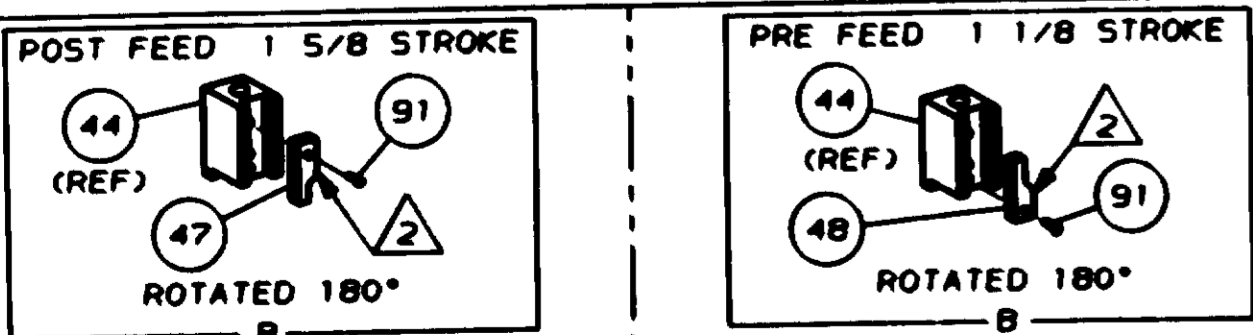

CRIMPING DATA			
PAD LTR	CRIMP HEIGHT	WIRE SIZE	WIRE STRIP LENGTH
A	.035	22	
B	.031	24	
C	.029	26	
D	.028	28	
CRIMP SIZE	TYPE	FEED	APPL INST
WIRE	.042	F	.220 A1 8040
INSUL	.065	F	

TERMINAL NAME: 22DF AMPLITE CONTACT

WIRE RANGE	INSULATION RANGE	SET UP GAGE	LAYOUT
28-22	.075-.085	458637-1	L1434

LOC A
DIST 66
LEADMAKER
T TERMINATING UNIT

AMP-O-LECTRIC
K TERMINATING UNIT
MACHINE NO. 565435-5

REVISION OF EACH ASSY NO (WHEN BLANK, USE DNG REVISION)

QTY REQD PER ASSY

PARTS LIST

MATERIAL

HT TR

FIN

DIMENSIONS IN INCHES. DO NOT SCALE PRINT. TOLERANCES UNLESS OTHERWISE SPECIFIED.

DR: P. MATHIAS 10/27/91 APP: -

CHK: 1-24-92 REL: 1-27-92

C: ERISMAN M: MCPHERSON

NAME: SIDE FEED HDM APPLICATOR MACHINE REF MINI APPL

SCALE: NIS DNG NO: 567429 SHEET 1 of 1 REV B

THIS DRAWING IS A CONTROLLED DOCUMENT FOR AMP INCORPORATED. IT IS SUBJECT TO CHANGE AND THE CONTROLLER HAS THE RIGHT TO REVOKE AUTHORITY TO USE THIS DRAWING WITHOUT NOTICE. ORGANIZATION SHOULD BE CONTACTED FOR THE LATEST REVISION.

THIS INFORMATION IS CONFIDENTIAL AND IS DISCLOSED TO YOU ON THE CONDITION THAT YOU WILL NOT DISCLOSE IT TO OTHER THAN AMP PERSONNEL WITHOUT THE WRITTEN AUTHORIZATION FROM AMP INCORPORATED, ADMINSTRATIVE, PH.