

F²MC-16L/LX Family EMULATOR
RAM MONITOR BOARD
MB2147-80
OPERATION MANUAL

PREFACE

Thank you for purchasing the F²MC-16L/16LX family emulator RAM monitor board(model MB2147-80).

The MB2147-80 is a development support tool to be used in combination with the F²MC-16L/16LX emulator (MB2147-01), PGA-256P adpter board(MB2147-10), and PGA-299P adpter board (MB2147-20) to develop and evaluate application products based on the Fujitsu F²MC-16L/16LX family of microcontrollers.

This manual is intended for engineers who use the MB2147-80 (hereafter called the RAM monitor board) to develop applied products based on Fujitsu's F²MC-16L/16LX Family microcontrollers. The manual describes how to handle the RAM monitor board and its functions as well as setting procedures. Be sure to read it before using the RAM monitor board.

* : F²MC is the abbreviation of FUJITSU Flexible Microcontroller.

■ Using the product safety

This manual contains important information required for using the MB2147-80 safely. Be sure to read through the manual before using the product and follow the instructions contained therein to use it correctly.

In particular, carefully read "Caution of the products described in this manual" at the beginning of this manual and Chapter 6 "Restrictions" to understand the requirements for safe use of the product before using it.

After reading the manual, keep it handy for future reference.

■ Product operating environment

Use the product at an operating temperature between 5 °C and 35 °C and at an operating humidity between 20% to 80%. Avoid using it in a hot or humid environment and prevent condensation.

The product is a frameless PC board unit with all electronic components exposed. Therefore, do not put anything on the product, do not touch or let an electrically charged material contact a metal part of it. Once the product has been powered, try to keep those objects away from it which may short-circuit it or easily catch fire and burn. Use the product as horizontal as possible and avoid operating it at a place exposed to strong vibration, dust, or explosive gas.

Note that using the product not in the above operating environment may unexpectedly cause personal injury to the user (or another person if present near the product) or physical damage to properties around the product.

You should also keep the packaging materials used for shipping the product. They work well as they are when you transport the product again, for example, if it becomes out of order and needs to be repaired.

■ Organization of this manual

This manual consists of the following six chapters. Be sure to read them all before using the product.

Chapter 1 Product Overview and Handling Precautions

This chapter provides an overview of the RAM monitor board and its handling precautions.

Chapter 2 Product Description

This chapter describes the configuration of the hardware system incorporating the RAM monitor board and shows the names of its components as well as the major specifications.

Chapter 3 Functions

This chapter describes the functions of the RAM monitor board.

Chapter 4 Connections

This chapter explains how to connect the RAM monitor board. Read this chapter before turning the power supply on.

Chapter 5 Usage

This chapter explains how to set the RAM monitor board. Read this chapter before turning the power supply on.

Chapter 6 Restrictions

This chapter describes restrictions on using the RAM monitor board. Read this chapter before turning the power supply on.

■ Related manuals

You should refer to the following manuals as well:

- F²MC-16L/16LX EMULATOR MB2147-01 HARDWARE MANUAL
- ADAPTER BOARD HARDWARE MANUAL
- PROBE HEADER INSTRUCTION MANUAL
- PROBE CABLE INSTRUCTION MANUAL
- SOFTUNE WORKBENCH OPERATION MANUAL

■ Caution of the products described in this manual

The following precautions apply to the product described in this manual.



Indicates a potentially hazardous situation which, if not avoided appropriately, could result in death or serious injury and/or a fault in the user's system.

Electric shock, Damage	Before performing any operation described in this manual, turn off all the power supplies to the system. Performing such an operation with the power on may cause an electric shock or device fault.
Electric shock, Damage	Once the product has been turned on, do not touch any metal part of it. Doing so may cause an electric shock or device fault.



CAUTION

Indicates a potentially hazardous situation which, if not avoided appropriately, may result in minor or moderate injury and/or damage to the product or the equipment to which the product is connected, to software resources such as data, or to other properties.

Cuts, Damage	Before moving the product, be sure to turn off all the power supplies and unplug the cables. Watch your steps when carrying the product. Do not use the product at an unstable location such as a place exposed to strong vibration or a sloping surface. Doing so may let the product fall, resulting in an injury or fault.
Cuts	The product has some sharp-pointed or edged parts inevitably exposed, such as Monitor pins. Use meticulous care in handling the product not to get injured with such pointed parts.
Damage	Turn the power off before setting switches or jumper plugs.
Damage	Neither put anything on or apply shock to the product. Once the product has been powered, do not carry it. Doing either may cause a fault due to a load or shock.
Damage	Since the product contains many electronic components, keep it away from direct sunlight, high temperature, and high humidity to prevent condensation. Do not use or store the product where it is exposed to much dust or a strong magnetic or electric field for an extended period of time. An adverse operating or storage environment can cause a fault.
Damage	Use the product within the ranges of its general specifications. Operating it outside the range of any general specification may cause a fault.
Damage	To prevent electrostatic breakdown, do not let your finger or an object touch any metal part of the connector. Before handling the product, touch a metal object (such as a door knob) to discharge static electricity from your body.
Damage	Turn off all the power to the system before performing any operation described in this manual. Failure to do so may result in an electric shock or device fault.
Damage	Be sure to turn the power off before plugging or unplugging the RAM monitor board or adapter board. When unplugging the RAM monitor board or adapter board, remove it with uniform force without forcing only one position.
Damage	When stored, the product should be kept in its packaging box as it has no housing. Re-transporting the product may damage it to cause a fault. Keep the packaging materials used for shipment of the product and use them when re-transporting it.

- The contents of this document are subject to change without notice. Customers are advised to consult with FUJITSU sales representatives before ordering.
- The information, such as descriptions of function and application circuit examples, in this document are presented solely for the purpose of reference to show examples of operations and uses of FUJITSU semiconductor device; FUJITSU does not warrant proper operation of the device with respect to use based on such information. When you develop equipment incorporating the device based on such information, you must assume any responsibility arising out of such use of the information. FUJITSU assumes no liability for any damages whatsoever arising out of the use of the information.
- Any information in this document, including descriptions of function and schematic diagrams, shall not be construed as license of the use or exercise of any intellectual property right, such as patent right or copyright, or any other right of FUJITSU or any third party or does FUJITSU warrant non-infringement of any third-party's intellectual property right or other right by using such information. FUJITSU assumes no liability for any infringement of the intellectual property rights or other rights of third parties which would result from the use of information contained herein.
- The products described in this document are designed, developed and manufactured as contemplated for general use, including without limitation, ordinary industrial use, general office use, personal use, and household use, but are not designed, developed and manufactured as contemplated (1) for use accompanying fatal risks or dangers that, unless extremely high safety is secured, could have a serious effect to the public, and could lead directly to death, personal injury, severe physical damage or other loss (i.e., nuclear reaction control in nuclear facility, aircraft flight control, air traffic control, mass transport control, medical life support system, missile launch control in weapon system), or (2) for use requiring extremely high reliability (i.e., submersible repeater and artificial satellite).
Please note that FUJITSU will not be liable against you and/or any third party for any claims or damages arising in connection with above-mentioned uses of the products.
- Any semiconductor devices have an inherent chance of failure. You must protect against injury, damage or loss from such failures by incorporating safety design measures into your facility and equipment such as redundancy, fire protection, and prevention of over-current levels and other abnormal operating conditions.
- If any products described in this document represent goods or technologies subject to certain restrictions on export under the Foreign Exchange and Foreign Trade Law of Japan, the prior authorization by Japanese government will be required for export of those products from Japan.

CONTENTS

Chapter 1 Product Overview and Handling Precautions	1
1.1 Overview	2
1.2 Checking the Items Packaged	3
1.3 Options	4
1.4 Notes on Use	5
Chapter 2 Product Description	7
2.1 System Configuration	8
2.2 Appearance and Part Names.....	9
2.3 General Specifications	10
Chapter 3 Functions	11
3.1 Function Specifications	12
3.2 Switch and Jumper Plug Specifications	13
3.3 Connector Specifications	14
Chapter 4 Connections	15
4.1 Connecting the RAM Monitor Board to Emulator	16
4.2 Connecting the RAM Monitor Board to the Adapter Board	17
Chapter 5 Usage	19
5.1 Setting the Ch1 / Ch2 Bank Switches	20
5.2 Setting Each Channel	21
5.3 Observing Monitor Data	22
5.4 Setup of Jumper Plug	23
Chapter 6 Restrictions	25

Chapter 1 Product Overview and Handling Precautions

This chapter provides an overview of the RAM monitor board and its handling precautions.

- 1.1 Overview
- 1.2 Checking the Items Packaged
- 1.3 Options
- 1.4 Notes on Use

1.1 Overview

This RAM monitor board is a development support tool for developing and evaluating hardware and software products which use the Fujitsu's F²MC-16L/16LX family of microcontrollers.

■ Overview

This product is an option to the F²MC-16L/16LX emulator (hereafter called the emulator), serving for supporting the development of user systems based on the Fujitsu F²MC-16L/16LX family of microcontrollers.

The RAM monitor board has the following major features;

- Used connected between the emulator and the adapter board (optional items).
- Monitors the status of data access to specific addresses of four channels and outputs access data to the monitor pins.
- Capable of specifying a measurement target bank for channels 1 and 2 (abbreviated ch1 and ch2) (the measurement target bank is common to ch1 and ch2).
- Measurement target for channels 3 and 4 (abbreviated ch3 and ch4) : Bank 00 fixed.
- Capable of setting the read, write, and read/write status for each channel

1.2 Checking the Items Packaged

Before using the RAM monitor board, check that the package contains the following items:

■ Checking the items packaged

Before using the RAM monitor board, check that the package contains the following items :

- RAM monitor board : 1
- Handling description (This manual in English and a Japanese version) : 1each

Note : Keep the packaging materials used for shipment of the product and use them when re-transporting it to prevent it from being damaged.

1.3 Options

Table 1.3-1 lists the options for RAM monitor board. Purchase them as required.

■ Options

Table 1.3-1 Options

Name	Part number
F ² MC-16L/16LX Emulator	MB2147-01
Adapter board *1	MB2147-xx
Probe cable *2	MB2132-xxx
Probe header *2	MB2147-xxx

*1 : The adapter board is an interface board that connects the emulator to the user system. Select and purchase the adapter board compatible with the evaluation MCU to be used. For selecting the adapter board, consult the Fujitsu sales representative or support division. For handling and using the adapter board and its safety precautions, refer to the "ADAPTER HARDWARE MANUAL."

*2 : The probe cable is an FPC cable for connection between the user system and the emulator. The probe header is a board that connects the user system to the emulator using a flat cable. Select and purchase the probe cable and probe header compatible with the package of the production MCU to be used. For selecting the probe header and probe cable, consult the Fujitsu sales representative or support division. For handling and using the probe cable and probe header and their safety precautions, refer to the "PROBE CABLE INSTRUCTION MANUAL" and "PROBE HEADER INSTRUCTION MANUAL."

1.4 Notes on Use

Take the precautions below when using the RAM monitor board.

■ Handling precautions

- Do not put anything on the RAM monitor board
- Be sure to turn the power off before plugging or unplugging any cable.
- Turn the power off before plugging or unplugging the RAM monitor board or adapter board.
- Turn the power off before setting switches or jumper plugs.
- To prevent electrostatic breakdown, do not let your finger or an object touch any metal part of the RAM monitor board, such as connector pins.
- The RAM monitor board has many sharp-pointed or edged parts exposed such as monitor pins. Handle the board with meticulous care not to get injured.

Note : To set up and use the RAM monitor board, follow the instructions in this manual.

■ Storing precautions

- Do not put anything on the RAM monitor board. When stored, the product should be kept in the packing box as it has no housing.
- Do not apply shock to the RAM monitor board.
- Keep the device away from direct sunlight, high temperature, and high humidity to prevent condensation.
- Since the product contains many electronic components, do not store it where it is exposed to a strong electric or magnetic field for an extended period of time.

Table 1.4-1 lists the operating and storage temperatures and humidities.

Table 1.4-1 Operating and storage environments

	Temperature	Humidity
During operation	5 °C to 35 °C	20% to 80% (No condensation allowed)
During storage	0 °C to 70 °C	20% to 80% (No condensation allowed)

Memo

Chapter 2 Product Description

This chapter describes the configuration of the hardware system incorporating the RAM monitor board and shows the names of its components as well as the major specifications.

- 2.1 System Configuration
- 2.2 Appearance and Part Names
- 2.3 General Specifications

2.1 System Configuration

The RAM monitor board is used in combination with the emulator and the adapter board and connected to the user system.

■ System configuration

Figure 2.1-1 shows the system configuration for the RAM monitor board.

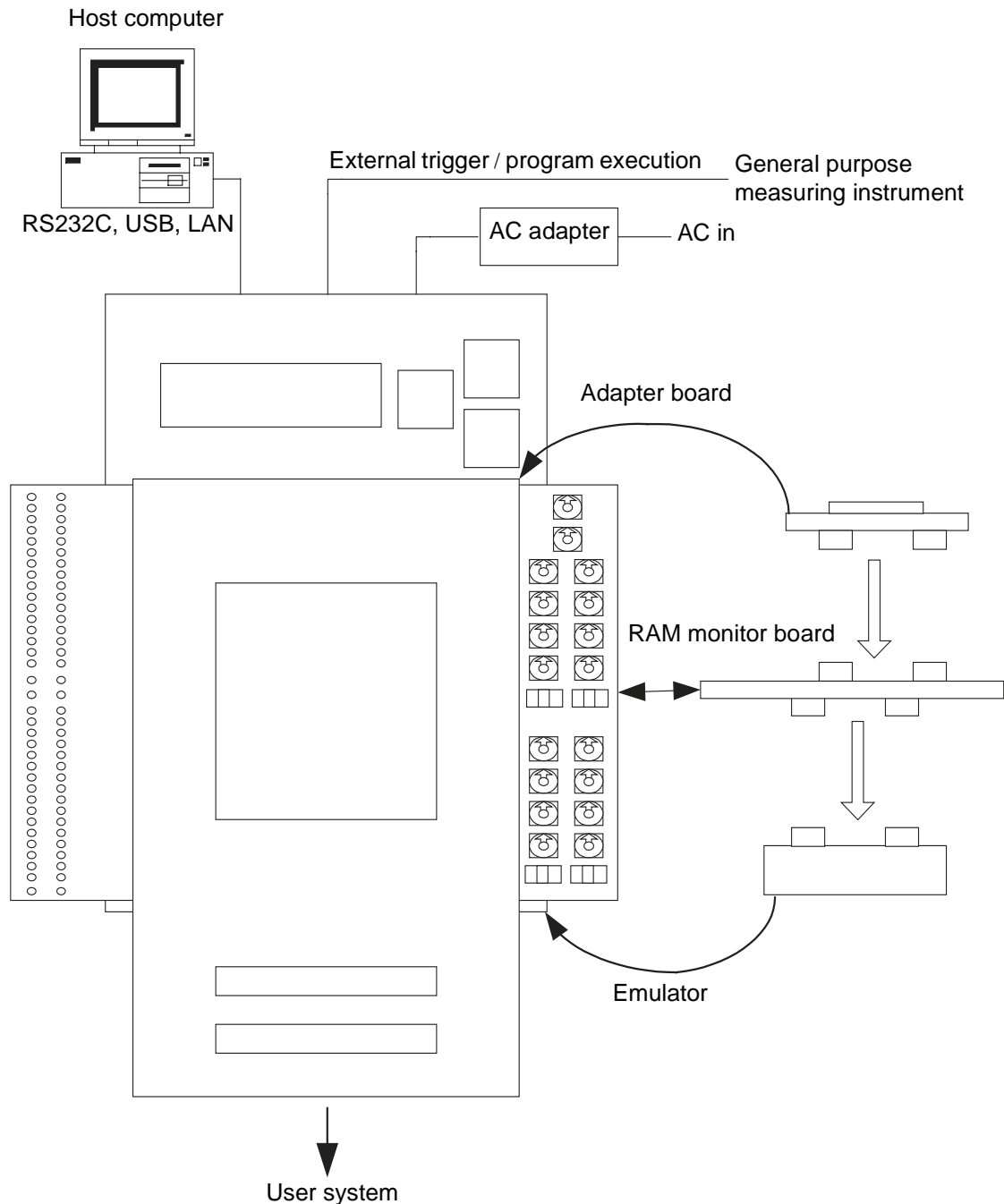

Figure 2.1-1 System configuration diagram

To use the emulator and adapter board, you need the host computer and emulator debugger software separately from this product. For connecting the adapter board to the user system, refer to the hardware manual for the adapter board. For information on the specifications of the emulator and adapter board, refer to their hardware manuals and instruction manuals.

2.2 Appearance and Part Names

Figure 2.2-1 gives an external view of the RAM monitor board to identify each part of it.

■ Appearance and part names

Figure 2.2-1 gives an external view of the RAM monitor board to identify each part of it. The RAM monitor board illustrated in Figure 2.2-1 is in the factory default states.

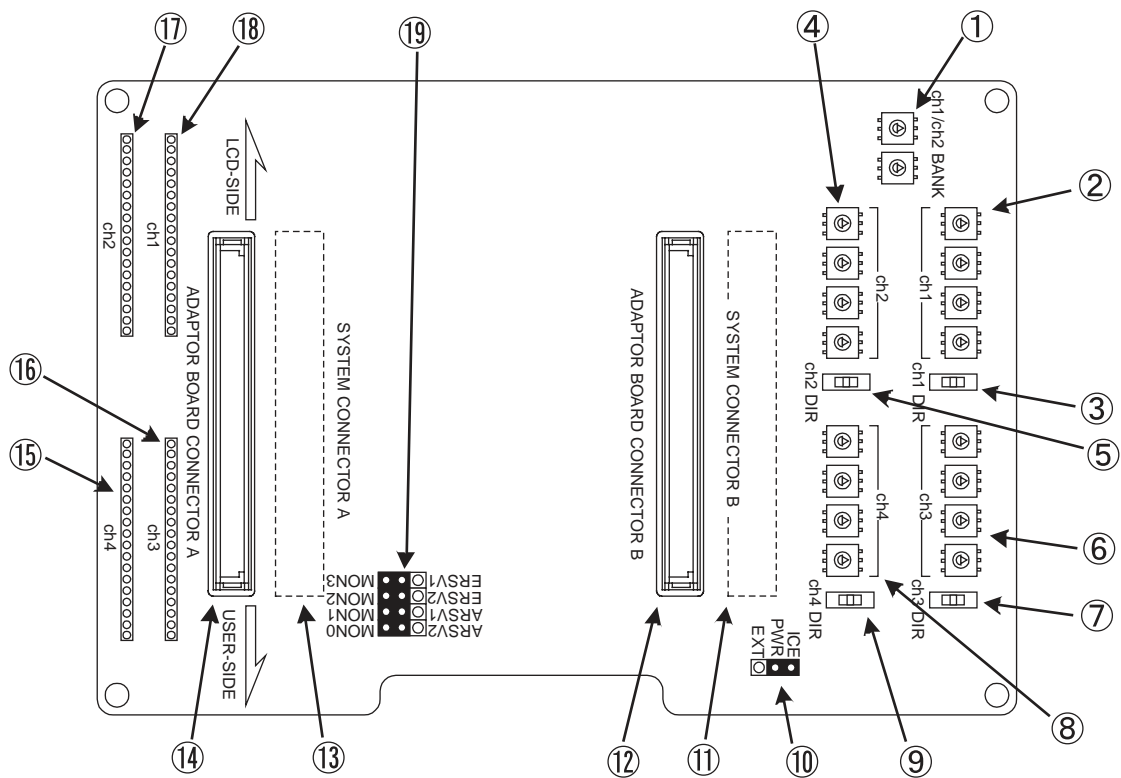

Number	Contents	Number	Contents
①	Ch1/ch2 BANK switch	⑫	Adapter board connector B
②	Ch1switch	⑬	System connector A
③	Ch1 DIR switch	⑭	Adapter board connector A
④	Ch2 switch	⑮	Ch4 monitor pin
⑤	Ch2 DIR switch	⑯	Ch3 monitor pin
⑥	Ch3 switch	⑰	Ch2 monitor pin
⑦	Ch3 DIR switch	⑱	Ch1 monitor pin
⑧	Ch4 switch	⑲	ARSV2 • MON0 switching jumper plug ARSV1 • MON1 switching jumper plug ERSV2 • MON2 switching jumper plug ERSV1 • MON3 switching jumper plug
⑨	Ch4 DIR switch		
⑩	PWR jumper plug		
⑪	System connector B		

Figure 2.2-1 External view

2.3 General Specifications

Table 2.3-1 lists the general specifications of the RAM monitor board.

■ General specifications

Table 2.3-1 lists the general specifications of the RAM monitor board.

Table 2.3-1 General specifications

Item	Specifications	
Name	F ² MC-16L/16LX Emulator RAM monitor board.	
Part number	MB2147-80	
Power supplies	RAM monitor board Power supply	+ 5V (Supplied from emulator)
Operating frequency	33 MHz max.	
Operating temperature	5 °C to 35 °C	
Operating humidity	20 % to 80 % (No condensation allowed)	
Dimensions	170 mm (W) × 150 mm (D) × 22 mm (H)	
Weight	145.6 g	

Note : Operating the device outside the range of any general specification may cause the device to malfunction. Use the device in the ranges of its general specifications.

Chapter 3 Functions

This chapter describes the functions of the RAM monitor board.

3.1 Function Specifications

3.2 Switch and Jumper Plug Specifications

3.3 Connector Specifications

3.1 Function Specifications

Table 3.1-1 lists the function specifications of the RAM monitor board.

■ Function specifications

Table 3.1-1 lists the major function specifications of the RAM monitor board.

Table 3.1-1 RAM monitor board functional specifications

Item	Description	
Emulator / adapter board connectors	Equipped with the connectors for accepting the emulator and adapter board.	
RAM monitor function	Extracts data on access to specific addresses of four channels and outputs it to the monitor pins in real time. Of all the four channels, two are addressed in fixed bank 00 and the other two are addressed in the same bank specified by the user.	
	Ch1	Bank selectable (Different banks cannot be specified for ch1 and ch2.)
	Ch2	Bank selectable (Different banks cannot be specified for ch1 and ch2.)
	Ch3	Bank 00 fixed
	Ch4	Bank 00 fixed
	Capable of specifying an attribute (read, write, or read/write) of access to the measurement target address for each channel.	

3.2 Switch and Jumper Plug Specifications

The table below lists the specifications of the switches and jumper plugs on the RAM monitor board.

■ Switch and jumper plug specifications

Table 3.2-1 lists the specifications of the switches and jumper plugs.

Table 3.2-1 Switch and jumper plug specifications

Item	Description
Ch1 / ch2 BANK switches	Select a bank for ch1 and ch2.
Ch1 switch	Select an address (A[15:0]) for ch1.
Ch1 DIR switch	Specifies the read, write, or read / write status for ch1.
Ch2 switch	Select an address (A[15:0]) for ch2.
Ch2 DIR switch	Specifies the read, write, or read / write status for ch2.
Ch3 switch	Select an address (A[15:0]) for ch3.
Ch3 DIR switch	Specifies the read, write, or read / write status for ch3.
Ch4 switch	Select an address (A[15:0]) for ch4.
Ch4 DIR switch	Specifies the read, write, or read / write status for ch4.
PWR jumper plug	Not used. Leave this factory-set.
ARSV2 • MON0 switching jumper plug	Not used. Leave this factory-set.
ARSV1 • MON1 switching jumper plug	Not used. Leave this factory-set.
ERSV2 • MON2 switching jumper plug	Not used. Leave this factory-set.
ERSV1 • MON3 switching jumper plug	Not used. Leave this factory-set.

3.3 Connector Specifications

The table below lists the specifications of the connectors on the RAM monitor board.

■ Connector specifications

Table 3.3-1 lists the specifications of the connectors.
The output circuit of a monitor pin is shown in Fig. 3.3-1.

Table 3.3-1 Connector specifications

Item	Description
Adapter board connector A/B	Accepts the adapter board. As the connector structure allows reverse plugging, pay attention to the silk-screen indication on the RAM monitor board when connecting the adapter board.
System connector A/B	Accepts the emulator. As the connector structure allows reverse plugging, pay attention to the silk-screen indication on the RAM monitor board when connecting the emulator.
Ch1 monitor pin	Monitors the status of data access to the address specified in ch1. Ground pins are provided at both ends.
Ch2 monitor pin	Monitors the status of data access to the address specified in ch2. Ground pins are provided at both ends.
Ch3 monitor pin	Monitors the status of data access to the address specified in ch3. Ground pins are provided at both ends.
Ch4 monitor pin	Monitors the status of data access to the address specified in ch4. Ground pins are provided at both ends.

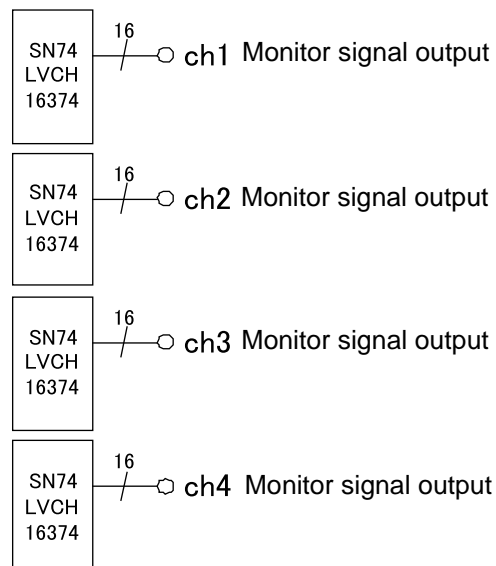

- Output directly from SN74LVCH16374 (TI product, VCC : 3.3V) with no additional circuit.

Figure 3.3-1 Monitor signal output circuit

Chapter 4 Connections

This chapter explains how to connect individual devices before turning their power on.

4.1 Connecting the RAM Monitor Board to the Emulator

4.2 Connecting the RAM Monitor Board to the Adapter Board

Note : Shut off power to the entire system before starting the operations described in this chapter. Performing such operations with the power on may result in electric shock or device faults.

4.2 Connecting the RAM Monitor Board to the Adapter Board

Connect the RAM monitor board to the adapter board as illustrated in Figure 4.2-1.

■ Connecting the RAM monitor board to the adapter board

- The RAM monitor board and the adapter board can be reversely plugged due to their connector structures. When connecting them, pay attention to the silk-screen indication on the RAM monitor board.
- Orient the RAM monitor board and the adapter board as illustrated above, then fit the connectors on the emulator deep into the system connectors A and B on (the solder side of) the RAM monitor board.

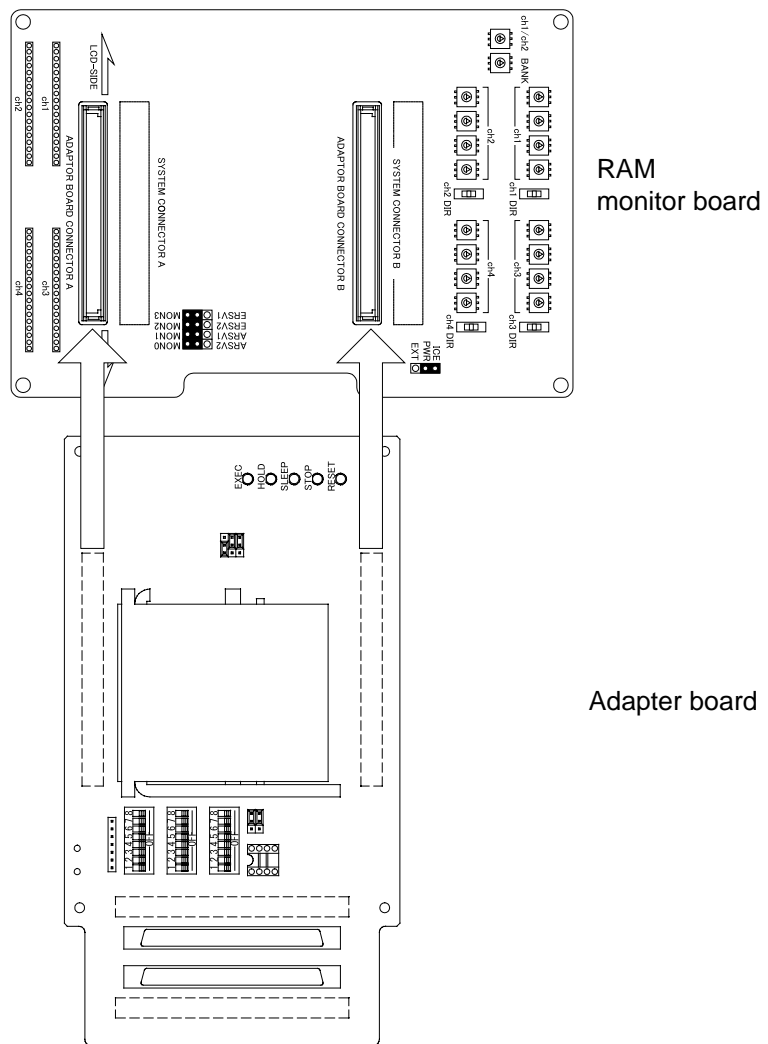

Figure 4.2-1 Connecting the RAM monitor board to the adapter board

Note : Turn the power off before plugging or unplugging the adapter board.

When unplugging the adapter board, remove it with uniform force without applying force to one point.

Memo

Chapter 5 Usage

This chapter describes the basic setup procedures to be followed before turning the power on and the power-on and shutdown procedures as well.

Be sure to read this chapter before turning the power on.

5.1 Setting the ch1/ch2 Bank Switches

5.2 Setting Each Channel

5.3 Observing Monitor Data

5.4 Setup of Jumper Plug

Note : Shut off power to the entire system before starting the operations described in this chapter. Performing such operations with the power on may result in electric shock or device faults.

5.1 Setting the Ch1/Ch2 Bank Switches

Ch1 / Ch2 Bank switch is describes.

■ Setting the ch1 / ch2 bank switches

Figure 5.1-1 shows the factory settings of the ch1/ch2 bank switches.

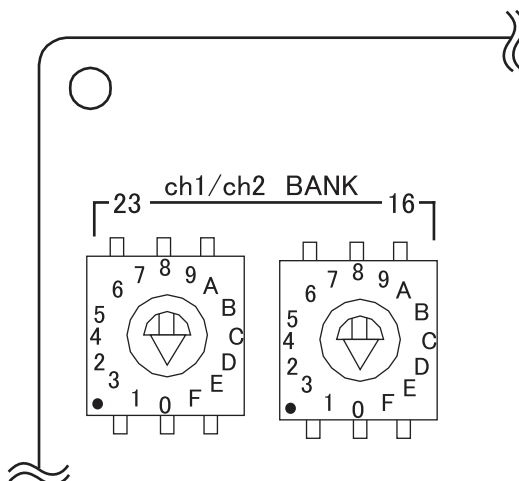

Figure 5.1-1 Setting the ch1/ch2 bank switches

Use two 0H-FH rotary switches to set the measurement target bank for ch1 and ch2. Use a standard screwdriver to set the arrow (triangle) notched in each knob to a desired digit. Note that the switches silk-printed 23 and 16 represent the high-order and low-order settings, respectively.

5.2 Setting Each Channel

This section describes how to set measurement addresses.

■ Each setup of channel

Figure 5.2-1 shows the factory settings of the switches for setting individual channels; Table 5.2-1 summarizes the functions of the switches.

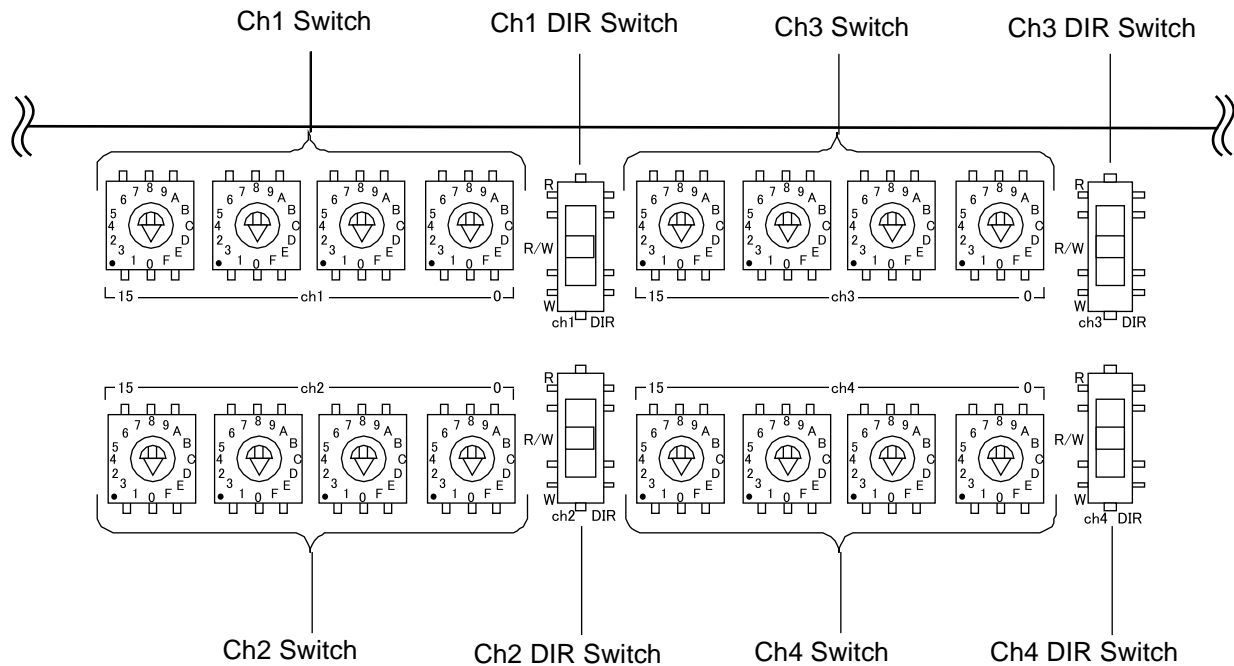

Figure 5.2-1 Setting each channel

Table 5.2-1 Setting each channel

Switch	Description
Ch1 switch Ch2 switch Ch3 switch Ch4 switch	Four 0H-FH rotary switches to set the measurement address for each channel. Use, for example, a standard screwdriver to set the arrow (triangle) notched in each knob to a desired digit. The switches silk-printed 15 and 0 represent the high-order and low-order settings, respectively.
Ch1 DIR switch Ch2 DIR switch Ch3 DIR switch Ch4 DIR switch	Set the status for each channel. R : Measure only read access. R/W : Measure read/write access. W : Measure only write access.

5.3 Observing Monitor Data

Connector a general-purpose measuring instrument to monitor pins to observe monitor data.

■ Connection to monitor pins

Connect a general-purpose measuring instrument to the monitor pins for each channel to observe monitor data.

Figure 5.3-1 shows the layout of the monitor pins for individual channels.

- Ground pins are located (silk-printed GND) at both ends of the array of monitor pins for each channel.
- Silk-printed numbers 15 and 0 represent the MSB and LSB of monitor data.

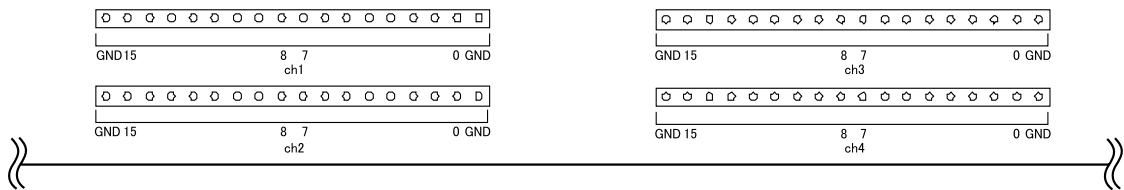

Figure 5.3-1 Assignment of the monitor pin of each channel

5.4 Setup of Jumper Plugs

This section describes the settings of jumper plugs.

■ Setup of jumper plugs

Figure 5.4-1 shows the factory settings of the jumper plugs. Do not touch the settings of the jumper plugs, or leave them factory-set.

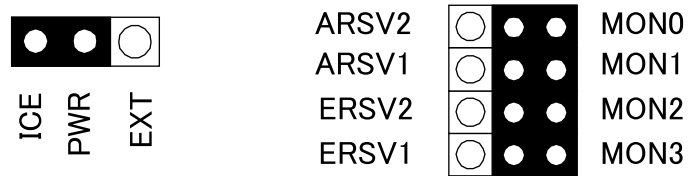

Figure 5.4-1 Setup of jumper plugs

Memo

Chapter 6 Restrictions

This chapter lists precautions and important notes on use of this product.

■ Restrictions

Listed below are general restrictions on the RAM monitor board:

- The RAM monitor function is not masked even during breaks. If a RAM-monitored address is accessed under control of the emulator during a break, therefore, the data accessed at this time is output. Output data from the RAM monitor board is thus valid only during execution of a user program.
- When the evaluation MCU is in its native mode, read access to its internal RAM / resource cannot be measured as data read at that time is not output as trace data.
- Neither internal ROM code access nor register read access can be measured as data read at that time is not output as trace data.
- When external memory access occurs, data bus information at access to the specified address is output to monitor pins. Pay attention to the location of valid data.
- Only write access can be measured when the measurement target is emulation memory.

Memo

SS01-71041-1E

FUJITSU SEMICONDUCTOR • SUPPORT SYSTEM

F²MC-16L/LX Family EMULATOR
RAM MONITOR BOARD
MB2147-80
OPERATION MANUAL

February 2005 the first edition

Published **FUJITSU LIMITED** Electronic Devices

Edited Business Promotion Dept.

FUJITSU