

# Magnetic Sensor Series

## Current Sensor IC

### BM14270AMUV-LB

#### General Description

This is the product guarantees long time support in industrial market.  
 BM14270AMUV-LB is coreless non-contact type current sensor of the magnetic detection using MI sensor. It's possible to measure the current line in non-contact, and therefore it's possible to measure current without loss.

#### Features

- Long Time Support Product for Industrial Applications
- Current Sensor using MI Element
- I<sup>2</sup>C Interface
- 14bit Digital Output

#### Applications

- Industrial Equipment
- Meter for the Power Measurement
- UPS
- Power Conditioner

#### Key Specifications

- Input Voltage Range: 2.7 V to 5.5 V
- Operating Current (20 SPS): 70  $\mu$ A(Typ)
- Magnetic Measurable Range:  $\pm$ 280  $\mu$ T(Typ)
- Magnetic Sensitivity: 0.045  $\mu$ T/LSB(Typ)
- Operating Temperature Range: -40 °C to +125 °C

#### Package

VQFN20QV3535

W(Typ) x D(Typ) x H(Max)

3.50 mm x 3.50 mm x 1.00 mm

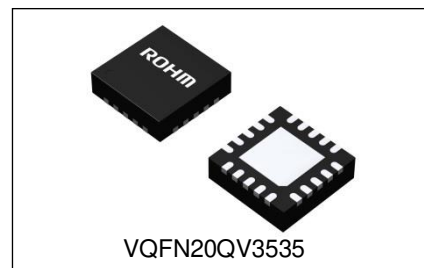

#### Typical Application Circuit and Block Diagram

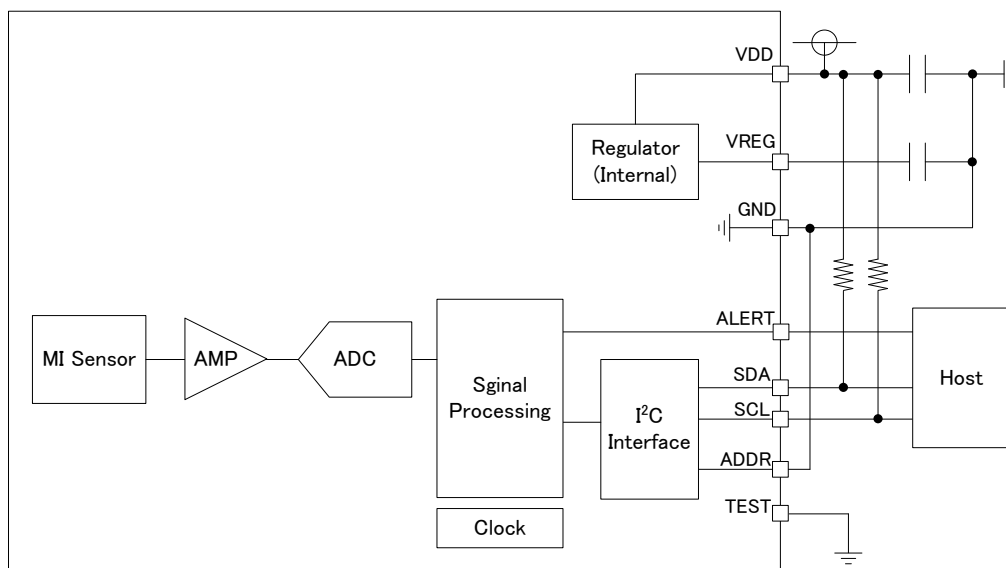

○Product structure : Silicon integrated circuit ○This product has no designed protection against radioactive rays

## Contents

General Description .....	1
Features .....	1
Applications .....	1
Key Specifications.....	1
Package .....	1
Typical Application Circuit and Block Diagram .....	1
Pin Configuration .....	3
Pin Description.....	3
Absolute Maximum Ratings .....	4
Thermal Resistance .....	4
Recommended Operating Conditions .....	5
Magnetic, Electrical Characteristics .....	5
Example of the Current Measurement Configuration .....	6
Typical Performance Curves.....	7
I <sup>2</sup> C Bus Timing Characteristics .....	8
I <sup>2</sup> C Bus Communication .....	8
I <sup>2</sup> C Bus Slave Address .....	9
Register Map .....	9
Control Sequence .....	11
Application Example.....	14
I/O Equivalence Circuits .....	15
Operational Notes .....	16
Ordering Information .....	18
Marking Diagram.....	18
Physical Dimension and Packing Information .....	19
Revision History.....	20

Pin Configuration

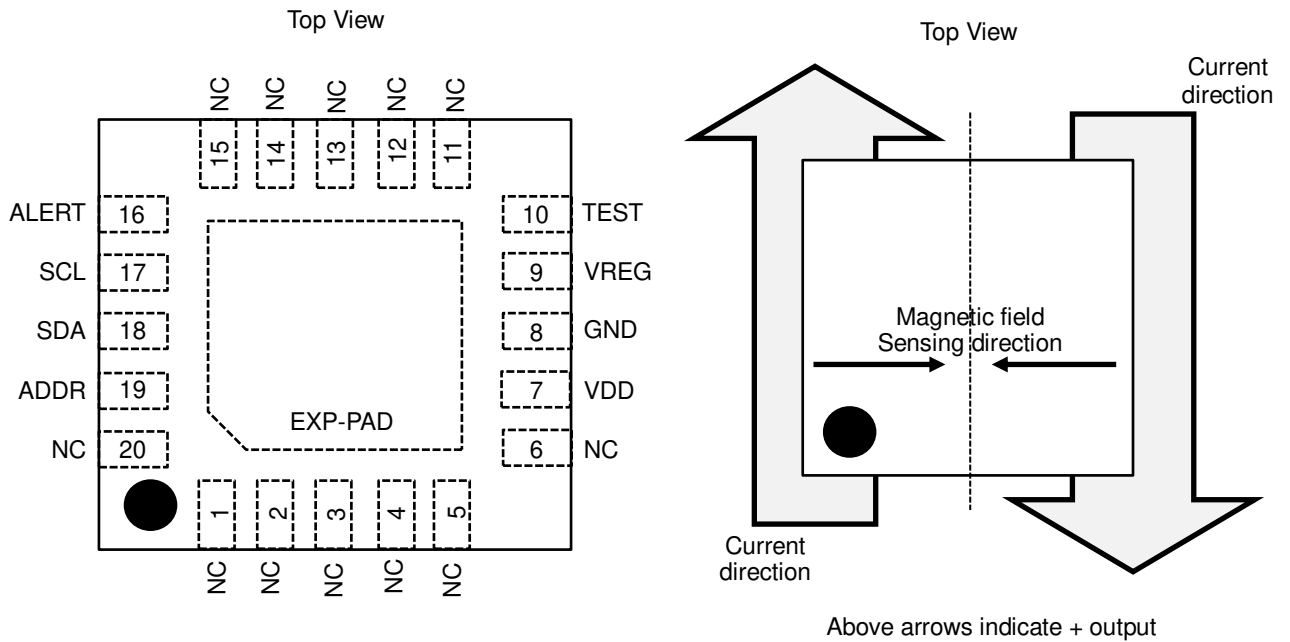

Above arrows indicate + output

Pin Description

Pin No.	Pin Name	Function
1	NC	No connection (Set to open)
2	NC	No connection (Set to open)
3	NC	No connection (Set to open)
4	NC	No connection (Set to open)
5	NC	No connection (Set to open)
6	NC	No connection (Set to open)
7	VDD	Power supply <sup>(Note 1)</sup>
8	GND	Ground
9	VREG	Internal regulator output <sup>(Note 2)</sup>
10	TEST	Test pin <sup>(Note 3)</sup>
11	NC	No connection (Set to open)
12	NC	No connection (Set to open)
13	NC	No connection (Set to open)
14	NC	No connection (Set to open)
15	NC	No connection (Set to open)
16	ALERT	ALERT output pin
17	SCL	I <sup>2</sup> C signal clock input
18	SDA	I <sup>2</sup> C signal data I/O
19	ADDR	I <sup>2</sup> C programmable address bit <sup>(Note 4)</sup>
20	NC	No connection (Set to open)
-	EXP-PAD	The EXP-PAD connect to GND or floating

(Note 1) Dispose a bypass capacitor between VDD and GND as close as possible to the IC.  
 (Note 2) Dispose a bypass capacitor between VREG and GND as close as possible to the IC.  
 Set a bypass capacitor of 0.22 μF between VREG and GND.  
 (Note 3) Connect to GND.  
 (Note 4) Connect to VDD or GND.

**Absolute Maximum Ratings (Ta=25 °C)**

Parameter	Symbol	Rating	Unit
Supply Voltage	V <sub>DD</sub>	7.0	V
Input Voltage	V <sub>IN</sub>	-0.3 to V <sub>DD</sub> +0.3	V
Storage Temperature Range	T <sub>stg</sub>	-40 to +150	°C
Maximum Junction Temperature	T <sub>jmax</sub>	150	°C
Maximum Exposed Field	M <sub>ef</sub>	-1000 to +1000	mT

**Caution 1:** Operating the IC over the absolute maximum ratings may damage the IC. The damage can either be a short circuit between pins or an open circuit between pins and the internal circuitry. Therefore, it is important to consider circuit protection measures, such as adding a fuse, in case the IC is operated over the absolute maximum ratings.

**Caution 2:** Should by any chance the maximum junction temperature rating be exceeded the rise in temperature of the chip may result in deterioration of the properties of the chip. In case of exceeding this absolute maximum rating, design a PCB with thermal resistance taken into consideration by increasing board size and copper area so as not to exceed the maximum junction temperature rating.

**Thermal Resistance** (Note 5)

Parameter	Symbol	Thermal Resistance (Typ)		Unit
		1s (Note 7)	2s2p (Note 8)	
VQFN20QV3535				
Junction to Ambient	θ <sub>JA</sub>	181.9	50.5	°C/W
Junction to Top Characterization Parameter (Note 6)	Ψ <sub>JT</sub>	19	7	°C/W

(Note 5) Based on JESD51-2A (Still-Air).

(Note 6) The thermal characterization parameter to report the difference between junction temperature and the temperature at the top center of the outside surface of the component package.

(Note 7) Using a PCB board based on JESD51-3.

(Note 8) Using a PCB board based on JESD51-5, 7.

Layer Number of Measurement Board	Material	Board Size
Single	FR-4	114.3 mm x 76.2 mm x 1.57 mmt

Top	
Copper Pattern	Thickness
Footprints and Traces	70 μm

Layer Number of Measurement Board	Material	Board Size	Thermal Via (Note 9)	
			Pitch	Diameter
4 Layers	FR-4	114.3 mm x 76.2 mm x 1.6 mmt	1.20 mm	Φ0.30 mm

Top		2 Internal Layers		Bottom	
Copper Pattern	Thickness	Copper Pattern	Thickness	Copper Pattern	Thickness
Footprints and Traces	70 μm	74.2 mm x 74.2 mm	35 μm	74.2 mm x 74.2 mm	70 μm

(Note 9) This thermal via connects with the copper pattern of all layers.

## Recommended Operating Conditions

Parameter	Symbol	Min	Typ	Max	Unit
Supply Voltage	V <sub>DD</sub>	2.7	5.0	5.5	V
I <sup>2</sup> C Clock Frequency	f <sub>SCL</sub>	-	-	400	kHz
Operating Temperature	Topr	-40	+25	+125	°C

Magnetic, Electrical Characteristics (Unless otherwise specified V<sub>DD</sub>=5.0 V Ta=25 °C)

Parameter	Symbol	Min	Typ	Max	Unit	Conditions
Current Consumption						
Operating Average Current	I <sub>DD</sub>	-	70	140	μA	Output Data Rate = 20 SPS
Power Down Mode Current	I <sub>SS</sub>	-	5	10	μA	ALL Power Down
Logic						
Low-level Input Voltage	V <sub>IL</sub>	GND	-	0.3 x V <sub>DD</sub>	V	
High-level Input Voltage	V <sub>IH</sub>	0.7 x V <sub>DD</sub>	-	V <sub>DD</sub>	V	
Low-level Input Current	I <sub>IL</sub>	-10	-	0	μA	V <sub>IL</sub> = GND
High-level Input Current	I <sub>IH</sub>	0	-	10	μA	V <sub>IH</sub> = V <sub>DD</sub>
Low-level Output Voltage	V <sub>OL</sub>	GND	-	0.2 x V <sub>DD</sub>	V	I <sub>LOAD</sub> = -0.3 mA
High-level Output Voltage	V <sub>OH</sub>	0.8 x V <sub>DD</sub>	-	V <sub>DD</sub>	V	I <sub>LOAD</sub> = 0.3 mA
Serial Communication						
Low-level Input Current	I <sub>IL2</sub>	-10	-	0	μA	V <sub>IL</sub> = GND
High-level Input Current	I <sub>IH2</sub>	0	-	10	μA	At HiZ, V <sub>IH</sub> = V <sub>DD</sub>
Low-level Output Voltage	V <sub>OL2</sub>	GND	-	0.2 x V <sub>DD</sub>	V	I <sub>LOAD</sub> = -3 mA
Magnetic Sensor						
Measurable Range	R <sub>M</sub>	-	±280	-	μT	
Linearity <sup>(Note 10)</sup>	L <sub>IN</sub>	-	0.5	2	%FS	
Output Offset	V <sub>OFS</sub>	-	0	-	LSB	
Magnetic Sensitivity	D <sub>ELTAV</sub>	-	0.045	-	μT/LSB	
Measurement Time	t <sub>MS</sub>	-	0.35	-	ms	

(Note 10) Linearity = Output Error / R<sub>M</sub> = (output - ideal output) / R<sub>M</sub>

**Example of the Current Measurement Configuration**

This product has two different sensors of the magnetic field detection direction. It is configuration to output difference of the magnetic field which two sensors detected. (Out = A - B)

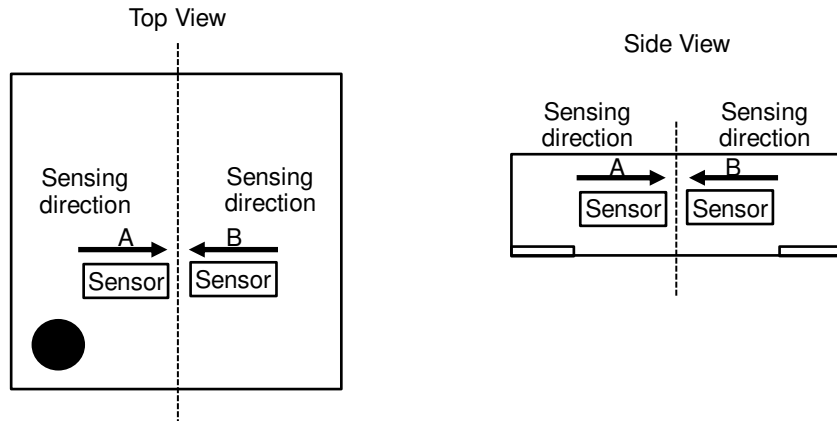

Figure 1. Sensor Configuration

This product locates on the board pattern such as follows, then the magnetic field of the different direction is applied to two sensors and can detect magnetic field depending on current. In addition, the disturbance magnetic field is applied to the same direction for two sensors, and can cancel disturbance magnetic field in the operating range.

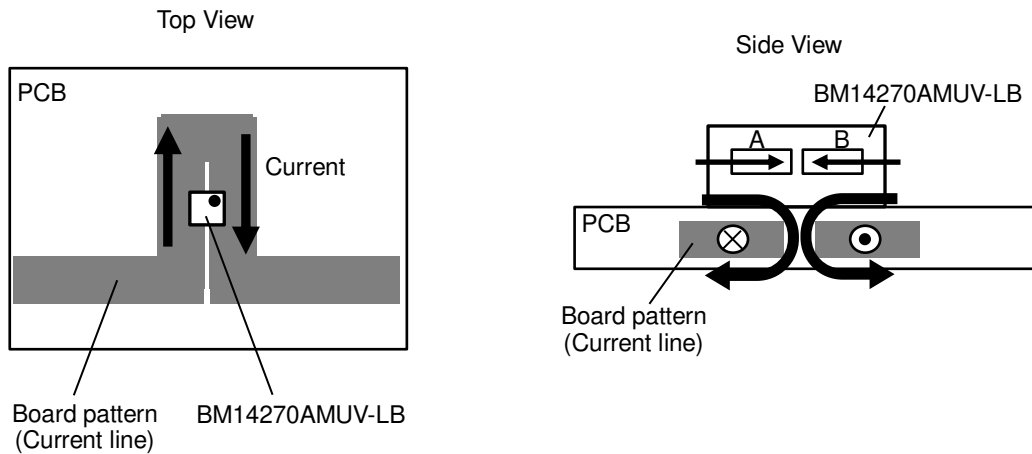

Figure 2. Example of the Board Pattern

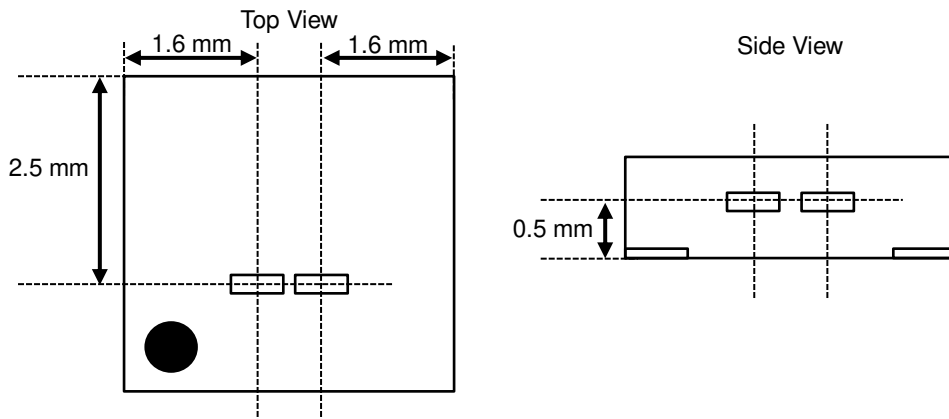

Figure 3. Position of the Sensor (Reference)

Typical Performance Curves

(Unless otherwise specified,  $V_{DD} = 5.0\text{ V}$ ,  $GND = 0.0\text{ V}$ ,  $T_a = 25\text{ }^\circ\text{C}$ )

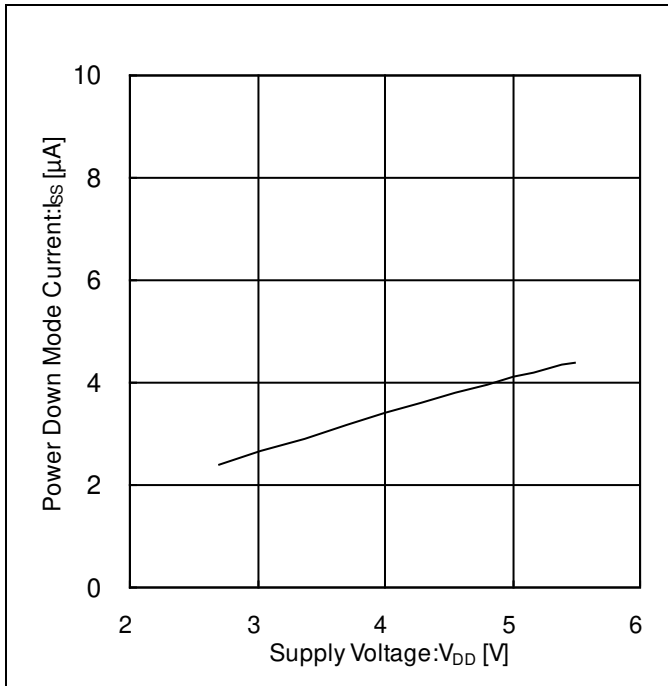

Figure 4. Power Down Mode Current vs Supply Voltage

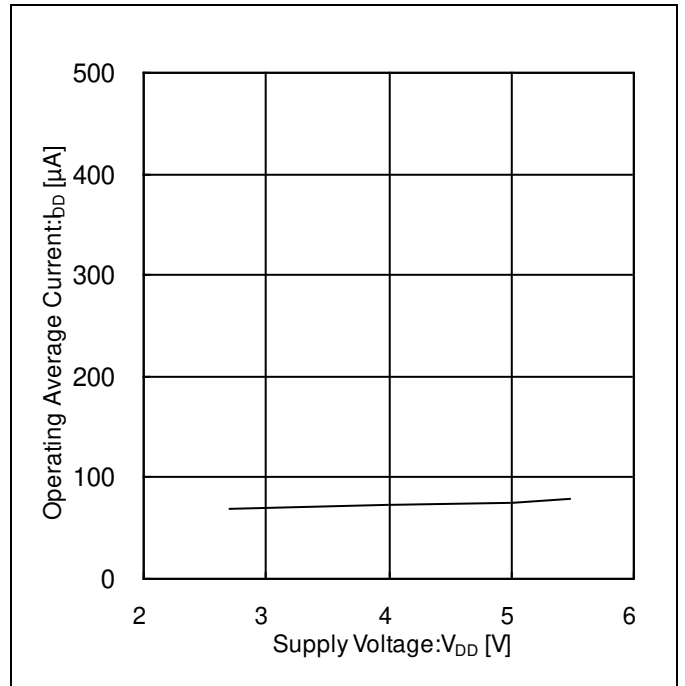

Figure 5. Operating Average Current vs Supply Voltage (20 SPS)

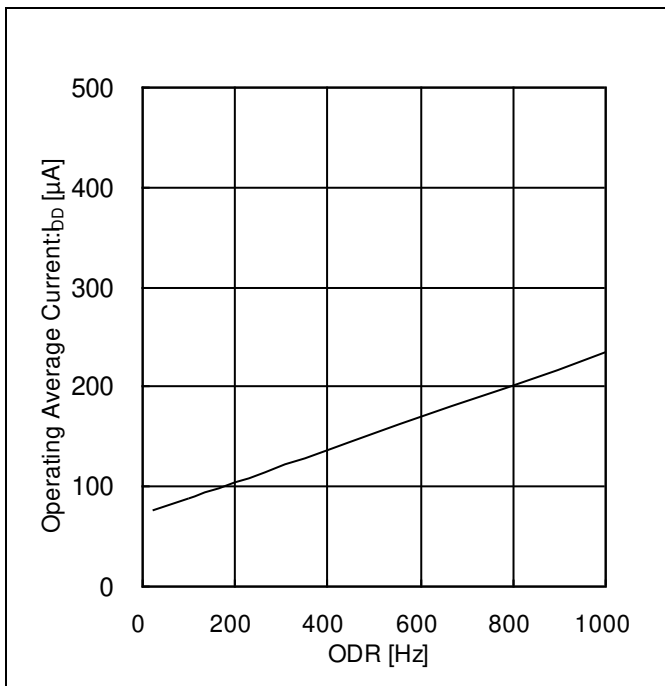

Figure 6. Operating Average Current vs ODR

I<sup>2</sup>C Bus Timing Characteristics (Unless otherwise specified V<sub>DD</sub> = 5.0 V, T<sub>a</sub> = 25 °C)

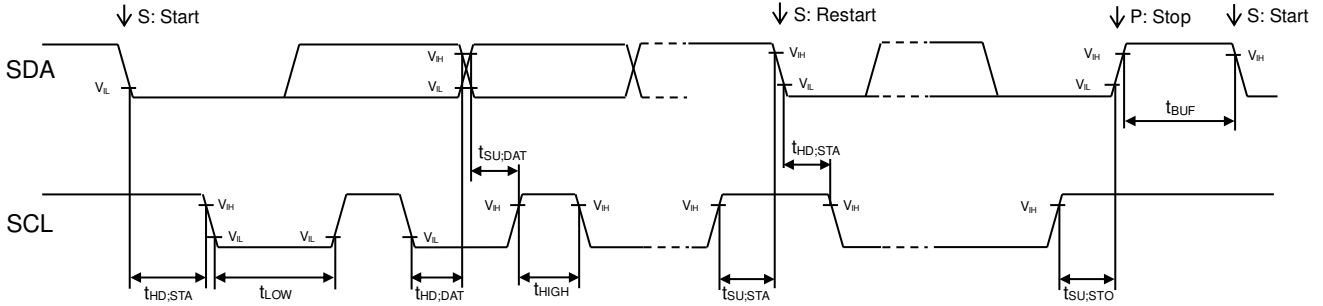

Figure 7. I<sup>2</sup>C Timing Chart

Parameter	Symbol	Min	Typ	Max	Unit	Conditions
SCL Clock Frequency	f <sub>SCL</sub>	0	-	400	kHz	
'L' Period of the SCL Clock	t <sub>LOW</sub>	1.3	-	-	μs	
'H' Period of the SCL Clock	t <sub>HIGH</sub>	0.6	-	-	μs	
Setup Time for Repeated START Condition	t <sub>SU,STA</sub>	0.6	-	-	μs	
Hold Time (Repeated) START Condition	t <sub>HD,STA</sub>	0.6	-	-	μs	
Data Setup Time	t <sub>SU,DAT</sub>	100	-	-	ns	
Data Hold Time	t <sub>HD,DAT</sub>	0	-	-	μs	
Setup Time for STOP Condition	t <sub>SU,STO</sub>	0.6	-	-	μs	
Bus Free Time between a STOP and START Condition	t <sub>BUF</sub>	1.3	-	-	μs	

I<sup>2</sup>C Bus Communication

1. Main write format

(1) Indicate register address

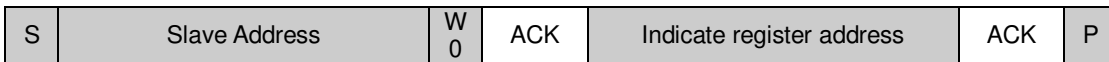

(2) Write to data register after indicating register address

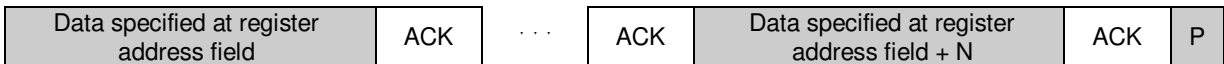
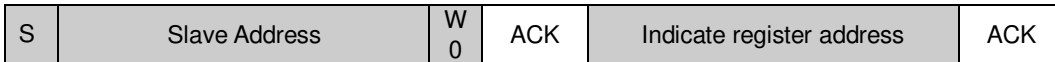

2. Main read format

(1) Read data after indicate register address

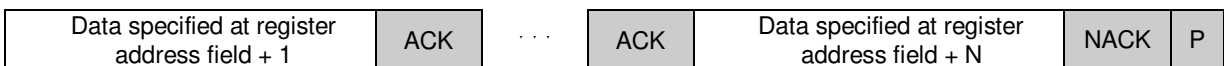
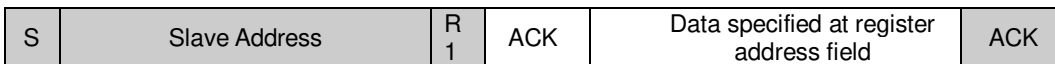
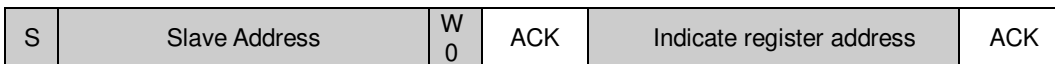

(2) Read data from the specified register

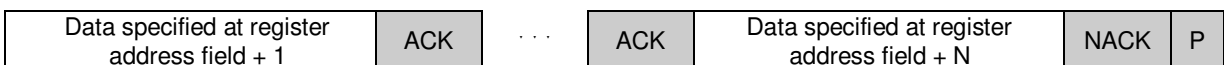
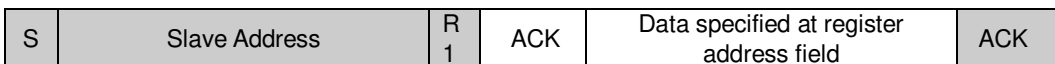

from master to slave

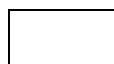

from slave to master



**I<sup>2</sup>C Bus Slave Address**

Selectable 2 I<sup>2</sup>C Slave Addresses by setting ADDR pin  
(ADDR=L: 0001110, ADDR=H: 0001111)

**Register Map** *(Note 11)*

Address	Register Name	R/W	D7	D6	D5	D4	D3	D2	D1	D0
0x0F	STA1	R	RD_ DRDY	0	0	0	0	0	0	0
0x10	DATA	R	DATA [7:0]							
0x11		R	DATA [15:8]							
0x1B	CNTL1	RW	PC1	0	RST_ LV	ODR [1:0]		0	FS1	0
0x1C	CNTL2	RW	0	0	0	0	ALERT_ EN	0	0	0
0x1D	CNTL3	RW	0	FORCE	0	0	0	0	0	0
0x5C	CNTL4	W	RSTB_LV [7:0]							
0x5D		W	RSTB_LV [15:8]							

*(Note 11)* Do not write any commands to other addresses except above. Do not write '1' to the fields in which value is '0' in above table.

It is the following conditions to be able to access each register.

Condition	Accessible Register
Supply Power	CNTL1 CNTL4
Supply Power (CNTL1) PC1=1 (CNTL1) RST_LV=0 (CNTL4) RSTB_LV=1	STA1 CNTL2 CNTL3
Supply Power (CNTL1) PC1=1 (CNTL1) RST_LV=0 (CNTL4) RSTB_LV=1 (CNTL3) FORCE=1 after first access	DATA

Register Map - continued

(0x0F) Status Register

Fields	Function
RD_DRDY	This bit informs the preparation status of the measured data 0: Waiting for end of measurement 1: Ready OK

default value 0x00

(0x10/0x11) Output Data Register

Fields	Function
DATA [7:0]	Output value LSB
DATA [15:8]	Output value MSB

default value 0xFFFF

signed 16 bit -8192d(0xE000) to +8191d(0x1FFF)

(0x1B) Control setting1 Register

Fields	Function
PC1	Power Control 0: Power Down 1: Active
RST_LV	Logic reset control 0: Reset release 1: Reset Reset release at RST_LV(CNTL1)=0 & RSTB_LV(CNTL4)=1
ODR [1:0]	Measurement output data rates 00: 20 Hz Mode 01: 100 Hz Mode 10: 200 Hz Mode 11: 1 kHz Mode
FS1	Measurement mode setting 0: Continuous mode 1: Single mode

default value 0x22

(0x1C) Control setting2 Register

Fields	Function
ALERT_EN	Select output signal of ALERT pin 0: No output 1: DRDY signal(Output RD_DRDY from pin)

default value 0x00

(0x1D) Control setting3 Register

Fields	Function
FORCE	AD start measurement trigger at continuous mode (FS1=0) and single mode (FS1=1) 1: Start measurement  Register is automatic clear "0" after write data "1" Write data "0" is invalid If write data "1" on measurement way, stop and restart measurement

default value 0x00

(0x5C/0x5D) Control setting4 Register

Fields	Function
RSTB_LV [7:0]	Reserved (ignore write data)
RSTB_LV [15:8]	RSTB_LV=1 by write access (ignore write data) Reset release at RST_LV(CNTL1)=0 & RSTB_LV(CNTL4)=1 RSTB_LV=0 by write PC1(CNTL1)=0

default value 0x00

Control Sequence

1. Control Sequence

1.1 Power supply start-up sequence

Do the command control by I<sup>2</sup>C after all powers are supplied.

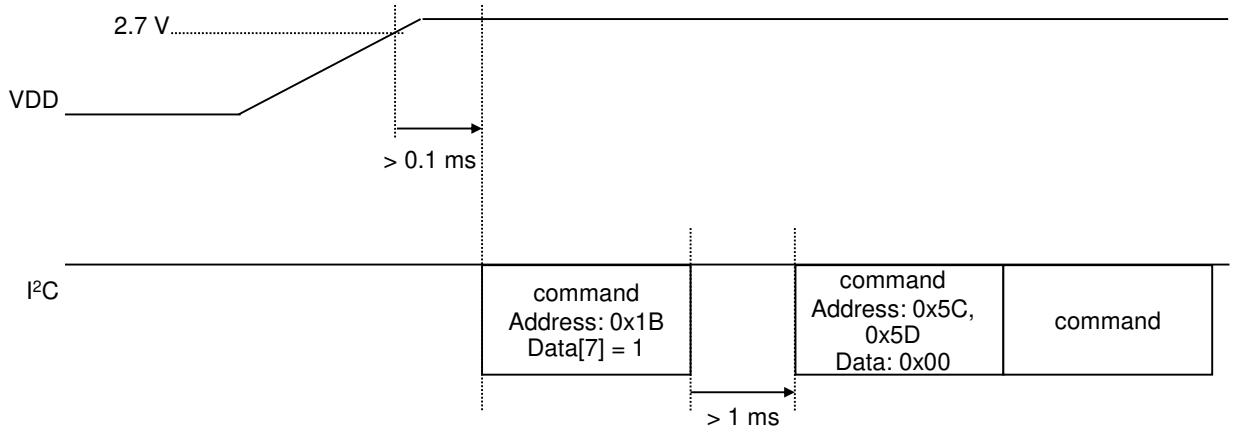

Figure 8. Timing Chart at Power ON

1.2 Power supply end sequence

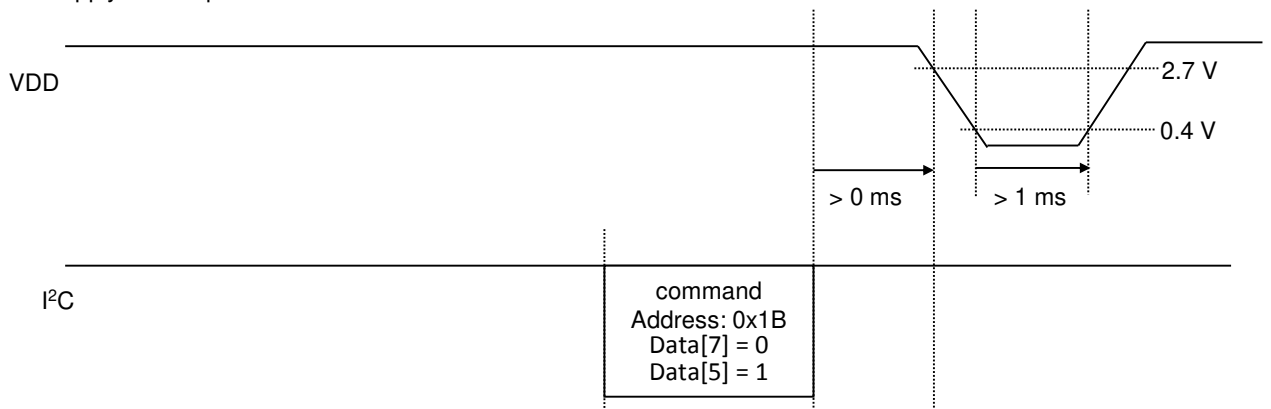

Figure 9. Timing Chart at Power OFF

Control Sequence - continued

2. Measurement sequence

There are the following two kinds of measurement modes

Continuous Mode	BM14270AMUV-LB is measured at specified cycle (ODR=20 Hz, 100 Hz, 200 Hz, 1 kHz) .
Single Mode	BM14270AMUV-LB is measured by the measurement request from the host.

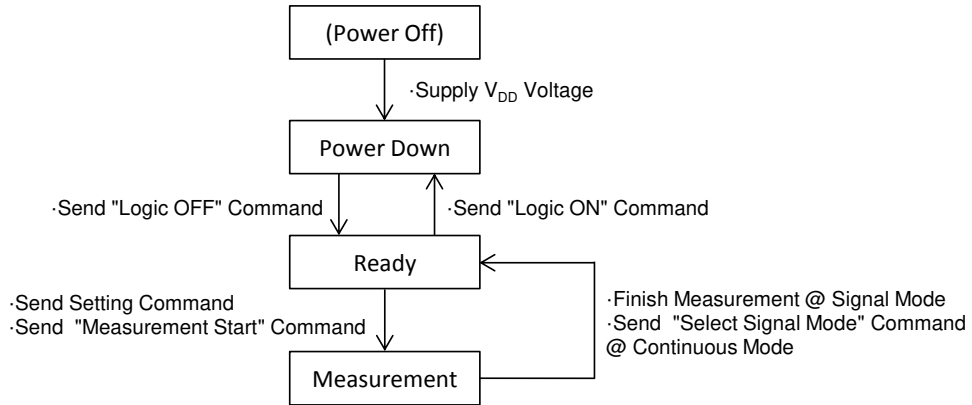

Figure 10. State Transition of Each Mode

2.1 Continuous Mode

(Send command example)

	Register Name	Address	Data
Step1	CNTL1	0x1B	0x80
	CNTL4	0x5C	0x00
Step2	CNTL2	0x1C	0x08
Step3	CNTL3	0x1D	0x40
Step4	STA1	0x0F	Read
	DATA	0x10	
		0x11	

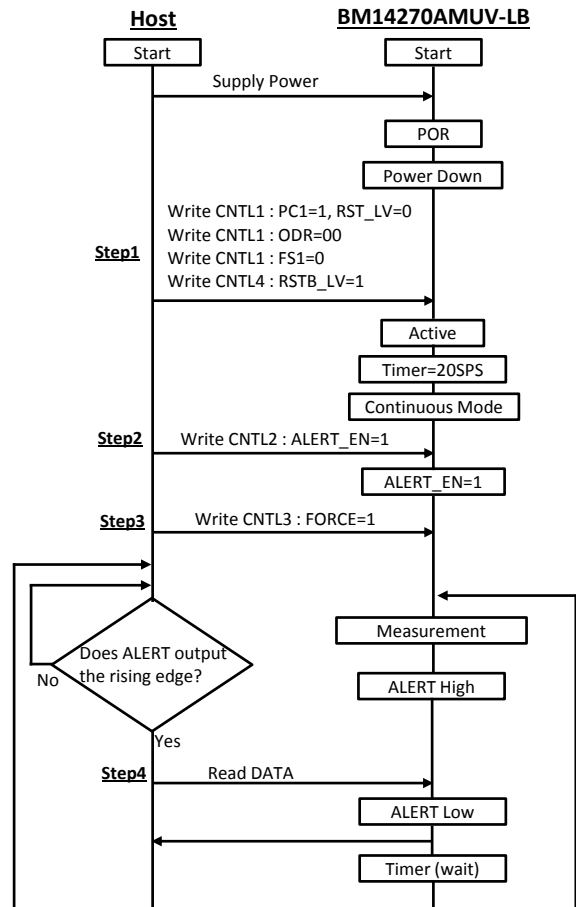

Figure 11. Sequence of Continuous Mode

Control Sequence - continued

2.2 Single Mode

(Send command example)

	Register Name	Address	Data
Step1	CNTL1	0x1B	0x82
	CNTL4	0x5C 0x5D	0x00
Step2	CNTL2	0x1C	0x08
Step3	CNTL3	0x1D	0x40
Step4	STA1	0x0F	Read
	DATA	0x10 0x11	

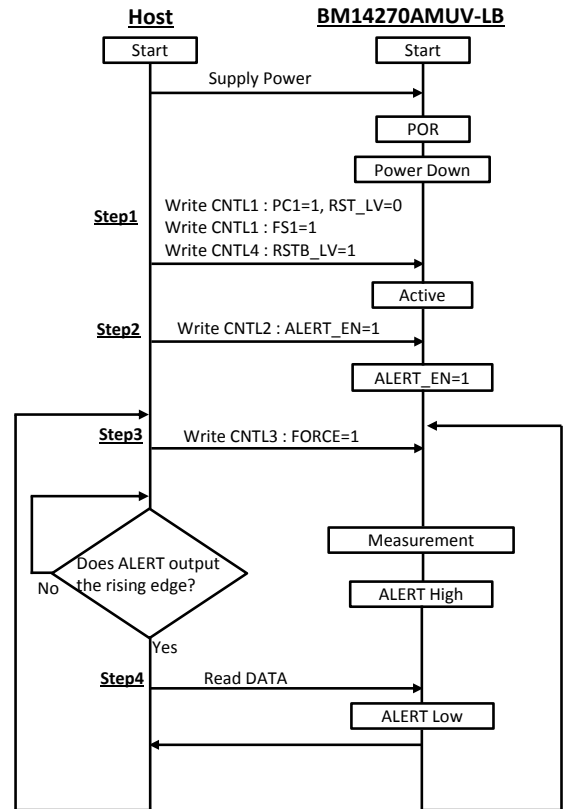

Figure 12. Sequence of Single Mode

Application Example

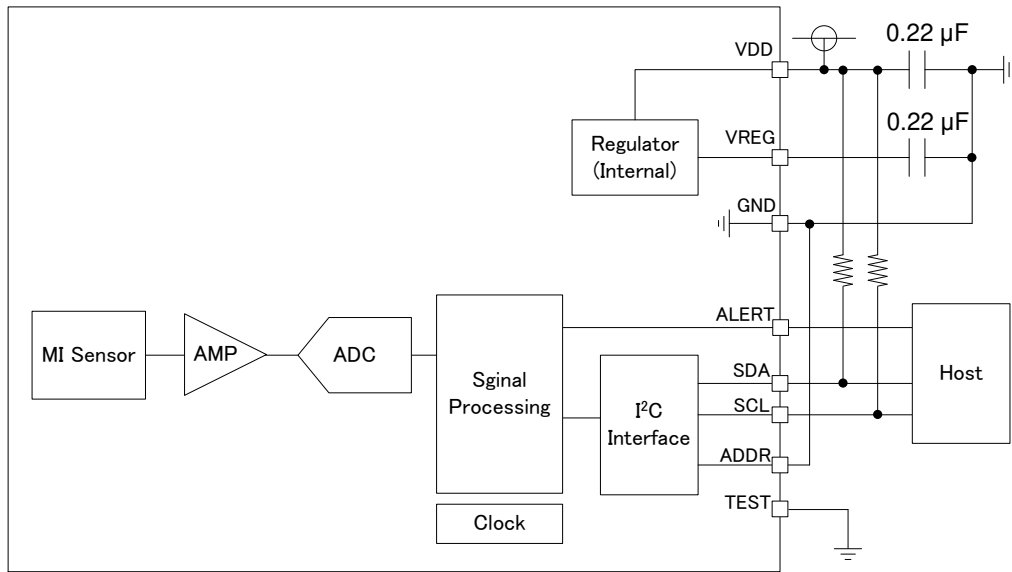

Figure 13. Example of Application Circuit

(Note) Sensor property may change due to around magnetic parts. We recommend calibrating the sensitivity and origin point of magnetic sensors after mounting.

I/O Equivalence Circuits

Pin Name	Equivalent Circuit Diagram	Pin Name	Equivalent Circuit Diagram
SCL		SDA	
ALERT		ADDR	
TEST		VREG	

## Operational Notes

### 1. Reverse Connection of Power Supply

Connecting the power supply in reverse polarity can damage the IC. Take precautions against reverse polarity when connecting the power supply, such as mounting an external diode between the power supply and the IC's power supply pins.

### 2. Power Supply Lines

Design the PCB layout pattern to provide low impedance supply lines. Furthermore, connect a capacitor to ground at all power supply pins. Consider the effect of temperature and aging on the capacitance value when using electrolytic capacitors.

### 3. Ground Voltage

Ensure that no pins are at a voltage below that of the ground pin at any time, even during transient condition.

### 4. Ground Wiring Pattern

When using both small-signal and large-current ground traces, the two ground traces should be routed separately but connected to a single ground at the reference point of the application board to avoid fluctuations in the small-signal ground caused by large currents. Also ensure that the ground traces of external components do not cause variations on the ground voltage. The ground lines must be as short and thick as possible to reduce line impedance.

### 5. Recommended Operating Conditions

The function and operation of the IC are guaranteed within the range specified by the recommended operating conditions. The characteristic values are guaranteed only under the conditions of each item specified by the electrical characteristics.

### 6. Inrush Current

When power is first supplied to the IC, it is possible that the internal logic may be unstable and inrush current may flow instantaneously due to the internal powering sequence and delays, especially if the IC has more than one power supply. Therefore, give special consideration to power coupling capacitance, power wiring, width of ground wiring, and routing of connections.

### 7. Testing on Application Boards

When testing the IC on an application board, connecting a capacitor directly to a low-impedance output pin may subject the IC to stress. Always discharge capacitors completely after each process or step. The IC's power supply should always be turned off completely before connecting or removing it from the test setup during the inspection process. To prevent damage from static discharge, ground the IC during assembly and use similar precautions during transport and storage.

### 8. Inter-pin Short and Mounting Errors

Ensure that the direction and position are correct when mounting the IC on the PCB. Incorrect mounting may result in damaging the IC. Avoid nearby pins being shorted to each other especially to ground, power supply and output pin. Inter-pin shorts could be due to many reasons such as metal particles, water droplets (in very humid environment) and unintentional solder bridge deposited in between pins during assembly to name a few.

### 9. Unused Input Pins

Input pins of an IC are often connected to the gate of a MOS transistor. The gate has extremely high impedance and extremely low capacitance. If left unconnected, the electric field from the outside can easily charge it. The small charge acquired in this way is enough to produce a significant effect on the conduction through the transistor and cause unexpected operation of the IC. So unless otherwise specified, unused input pins should be connected to the power supply or ground line.



Operational Notes – continued

10. Regarding the Input Pin of the IC

This IC contains P+ isolation and P substrate layers between adjacent elements in order to keep them isolated. P-N junctions are formed at the intersection of the P layers with the N layers of other elements, creating a parasitic diode or transistor. For example (refer to figure below):

- When GND > Pin A and GND > Pin B, the P-N junction operates as a parasitic diode.
- When GND > Pin B, the P-N junction operates as a parasitic transistor.

Parasitic diodes inevitably occur in the structure of the IC. The operation of parasitic diodes can result in mutual interference among circuits, operational faults, or physical damage. Therefore, conditions that cause these diodes to operate, such as applying a voltage lower than the GND voltage to an input pin (and thus to the P substrate) should be avoided.

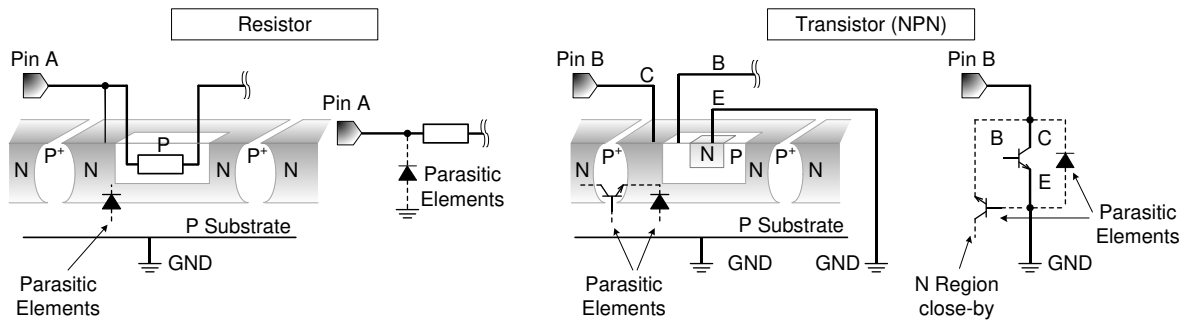
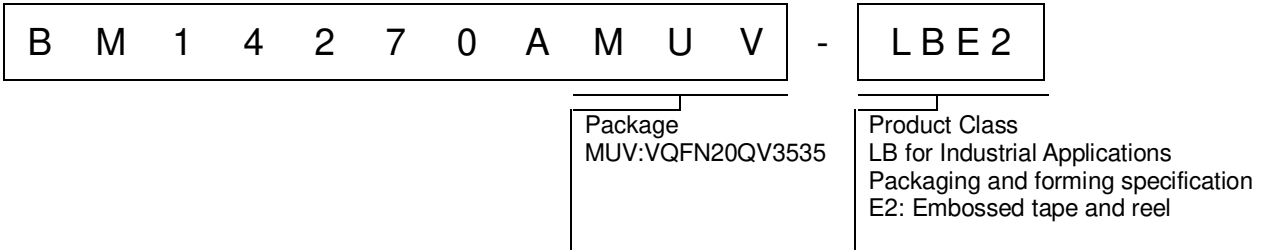

Figure 14. Example of IC Structure

11. Ceramic Capacitor

When using a ceramic capacitor, determine a capacitance value considering the change of capacitance with temperature and the decrease in nominal capacitance due to DC bias and others.

Ordering Information



Marking Diagram

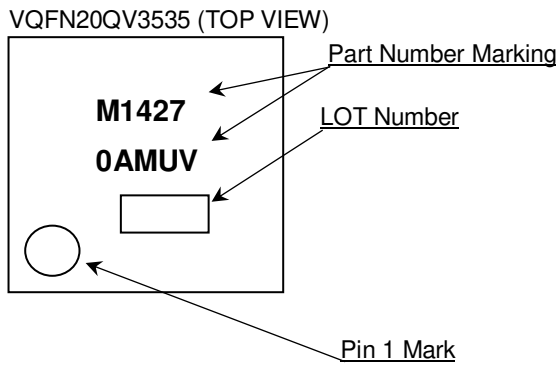

Physical Dimension and Packing Information

Package Name	VQFN20QV3535
--------------	--------------

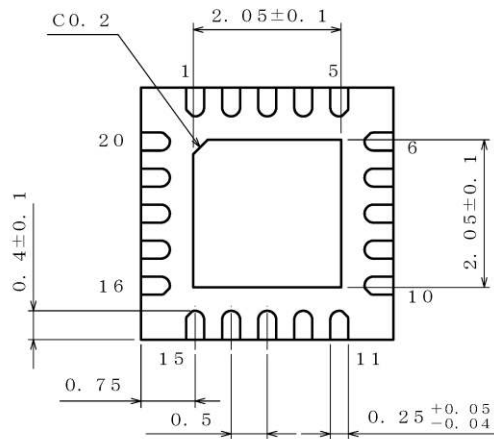
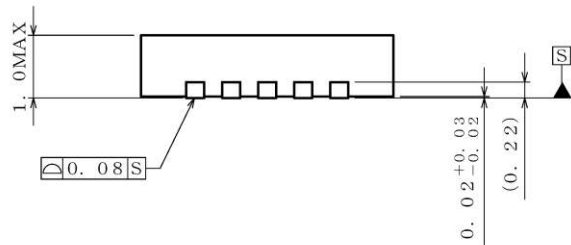
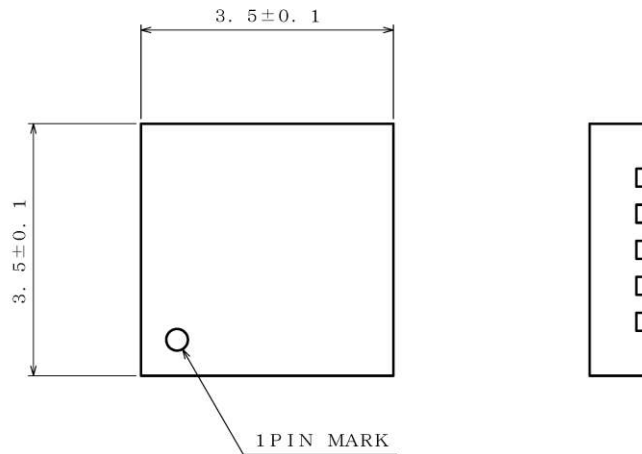

(UNIT : mm)  
 PKG : VQFN20QV3535  
 Drawing No. EX422-5001-1

< Tape and Reel Information >

Tape	Embossed carrier tape
Quantity	2500pcs
Direction of feed	E2 The direction is the pin 1 of product is at the upper left when you hold reel on the left hand and you pull out the tape on the right hand

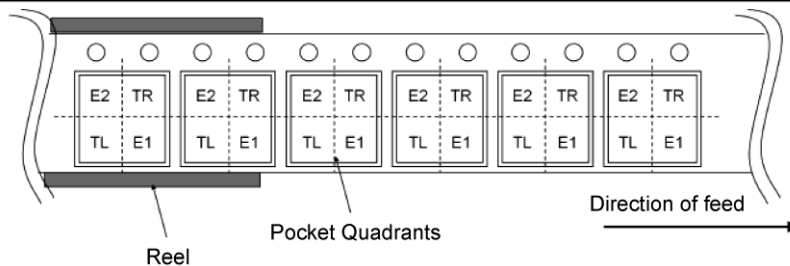

**Revision History**

Date	Revision	Changes
10.Oct.2019	001	New Release

# Notice

## Precaution on using ROHM Products

1. If you intend to use our Products in devices requiring extremely high reliability (such as medical equipment <sup>(Note 1)</sup>, aircraft/spacecraft, nuclear power controllers, etc.) and whose malfunction or failure may cause loss of human life, bodily injury or serious damage to property ("Specific Applications"), please consult with the ROHM sales representative in advance. Unless otherwise agreed in writing by ROHM in advance, ROHM shall not be in any way responsible or liable for any damages, expenses or losses incurred by you or third parties arising from the use of any ROHM's Products for Specific Applications.

(Note1) Medical Equipment Classification of the Specific Applications

JAPAN	USA	EU	CHINA
CLASS III	CLASS III	CLASS II b	CLASS III
CLASS IV		CLASS III	

2. ROHM designs and manufactures its Products subject to strict quality control system. However, semiconductor products can fail or malfunction at a certain rate. Please be sure to implement, at your own responsibilities, adequate safety measures including but not limited to fail-safe design against the physical injury, damage to any property, which a failure or malfunction of our Products may cause. The following are examples of safety measures:
  - [a] Installation of protection circuits or other protective devices to improve system safety
  - [b] Installation of redundant circuits to reduce the impact of single or multiple circuit failure
3. Our Products are not designed under any special or extraordinary environments or conditions, as exemplified below. Accordingly, ROHM shall not be in any way responsible or liable for any damages, expenses or losses arising from the use of any ROHM's Products under any special or extraordinary environments or conditions. If you intend to use our Products under any special or extraordinary environments or conditions (as exemplified below), your independent verification and confirmation of product performance, reliability, etc. prior to use, must be necessary:
  - [a] Use of our Products in any types of liquid, including water, oils, chemicals, and organic solvents
  - [b] Use of our Products outdoors or in places where the Products are exposed to direct sunlight or dust
  - [c] Use of our Products in places where the Products are exposed to sea wind or corrosive gases, including Cl<sub>2</sub>, H<sub>2</sub>S, NH<sub>3</sub>, SO<sub>2</sub>, and NO<sub>2</sub>
  - [d] Use of our Products in places where the Products are exposed to static electricity or electromagnetic waves
  - [e] Use of our Products in proximity to heat-producing components, plastic cords, or other flammable items
  - [f] Sealing or coating our Products with resin or other coating materials
  - [g] Use of our Products without cleaning residue of flux (Exclude cases where no-clean type fluxes is used. However, recommend sufficiently about the residue.); or Washing our Products by using water or water-soluble cleaning agents for cleaning residue after soldering
  - [h] Use of the Products in places subject to dew condensation
4. The Products are not subject to radiation-proof design.
5. Please verify and confirm characteristics of the final or mounted products in using the Products.
6. In particular, if a transient load (a large amount of load applied in a short period of time, such as pulse, is applied, confirmation of performance characteristics after on-board mounting is strongly recommended. Avoid applying power exceeding normal rated power; exceeding the power rating under steady-state loading condition may negatively affect product performance and reliability.
7. De-rate Power Dissipation depending on ambient temperature. When used in sealed area, confirm that it is the use in the range that does not exceed the maximum junction temperature.
8. Confirm that operation temperature is within the specified range described in the product specification.
9. ROHM shall not be in any way responsible or liable for failure induced under deviant condition from what is defined in this document.

## Precaution for Mounting / Circuit board design

1. When a highly active halogenous (chlorine, bromine, etc.) flux is used, the residue of flux may negatively affect product performance and reliability.
2. In principle, the reflow soldering method must be used on a surface-mount products, the flow soldering method must be used on a through hole mount products. If the flow soldering method is preferred on a surface-mount products, please consult with the ROHM representative in advance.

For details, please refer to ROHM Mounting specification

**Precautions Regarding Application Examples and External Circuits**

1. If change is made to the constant of an external circuit, please allow a sufficient margin considering variations of the characteristics of the Products and external components, including transient characteristics, as well as static characteristics.
2. You agree that application notes, reference designs, and associated data and information contained in this document are presented only as guidance for Products use. Therefore, in case you use such information, you are solely responsible for it and you must exercise your own independent verification and judgment in the use of such information contained in this document. ROHM shall not be in any way responsible or liable for any damages, expenses or losses incurred by you or third parties arising from the use of such information.

**Precaution for Electrostatic**

This Product is electrostatic sensitive product, which may be damaged due to electrostatic discharge. Please take proper caution in your manufacturing process and storage so that voltage exceeding the Products maximum rating will not be applied to Products. Please take special care under dry condition (e.g. Grounding of human body / equipment / solder iron, isolation from charged objects, setting of ionizer, friction prevention and temperature / humidity control).

**Precaution for Storage / Transportation**

1. Product performance and soldered connections may deteriorate if the Products are stored in the places where:
  - [a] the Products are exposed to sea winds or corrosive gases, including Cl<sub>2</sub>, H<sub>2</sub>S, NH<sub>3</sub>, SO<sub>2</sub>, and NO<sub>2</sub>
  - [b] the temperature or humidity exceeds those recommended by ROHM
  - [c] the Products are exposed to direct sunshine or condensation
  - [d] the Products are exposed to high Electrostatic
2. Even under ROHM recommended storage condition, solderability of products out of recommended storage time period may be degraded. It is strongly recommended to confirm solderability before using Products of which storage time is exceeding the recommended storage time period.
3. Store / transport cartons in the correct direction, which is indicated on a carton with a symbol. Otherwise bent leads may occur due to excessive stress applied when dropping of a carton.
4. Use Products within the specified time after opening a humidity barrier bag. Baking is required before using Products of which storage time is exceeding the recommended storage time period.

**Precaution for Product Label**

A two-dimensional barcode printed on ROHM Products label is for ROHM's internal use only.

**Precaution for Disposition**

When disposing Products please dispose them properly using an authorized industry waste company.

**Precaution for Foreign Exchange and Foreign Trade act**

Since concerned goods might be fallen under listed items of export control prescribed by Foreign exchange and Foreign trade act, please consult with ROHM in case of export.

**Precaution Regarding Intellectual Property Rights**

1. All information and data including but not limited to application example contained in this document is for reference only. ROHM does not warrant that foregoing information or data will not infringe any intellectual property rights or any other rights of any third party regarding such information or data.
2. ROHM shall not have any obligations where the claims, actions or demands arising from the combination of the Products with other articles such as components, circuits, systems or external equipment (including software).
3. No license, expressly or implied, is granted hereby under any intellectual property rights or other rights of ROHM or any third parties with respect to the Products or the information contained in this document. Provided, however, that ROHM will not assert its intellectual property rights or other rights against you or your customers to the extent necessary to manufacture or sell products containing the Products, subject to the terms and conditions herein.

**Other Precaution**

1. This document may not be reprinted or reproduced, in whole or in part, without prior written consent of ROHM.
2. The Products may not be disassembled, converted, modified, reproduced or otherwise changed without prior written consent of ROHM.
3. In no event shall you use in any way whatsoever the Products and the related technical information contained in the Products or this document for any military purposes, including but not limited to, the development of mass-destruction weapons.
4. The proper names of companies or products described in this document are trademarks or registered trademarks of ROHM, its affiliated companies or third parties.

### General Precaution

1. Before you use our Products, you are requested to carefully read this document and fully understand its contents. ROHM shall not be in any way responsible or liable for failure, malfunction or accident arising from the use of any ROHM's Products against warning, caution or note contained in this document.
2. All information contained in this document is current as of the issuing date and subject to change without any prior notice. Before purchasing or using ROHM's Products, please confirm the latest information with a ROHM sales representative.
3. The information contained in this document is provided on an "as is" basis and ROHM does not warrant that all information contained in this document is accurate and/or error-free. ROHM shall not be in any way responsible or liable for any damages, expenses or losses incurred by you or third parties resulting from inaccuracy or errors of or concerning such information.