

MLX92352/MLX92351

3-Axis Programmable Hall Effect Latch/Switch
Datasheet

1. Features and Benefits

- Triaxis® Hall Technology
- Dual Hall outputs
 - Two independent X, Y or Z magnetically sensitive open drain outputs
 - Quadrature outputs (90° phase shift) for pitch-independent design
 - Programmable independent magnetic thresholds and temperature coefficient
- High ESD capability and EMC robustness for PCB-less applications
- Programmable magnetic Latch, Unipolar or Omnipolar Switch functions
- Speed, Direction or Pulse output functions
- Selectable power-on state using start-up feedback to avoid miscounting
- Wide magnetic range from 0.5mT to 40mT
- Wide operating voltage range 2.7V to 60V
- 48V board net compatibility
- Low current consumption of 1.9mA
- Packages, RoHS compliant
 - VA-4L (PCB-less)
 - TSOT23-5L (SMD)
- AEC-Q100 and ASIL A capable device
- Integrated protections
 - Reverse supply voltage protection
 - Output short circuit protection by Thermal protection
 - Under-voltage reset

2. Application Examples

- Linear speed & direction control: power liftgate, closures with anti-pinch
- Incremental rotary encoding: cadence sensor for e-bikes, DC motor indexing, fan & pump motors
- Dual linear position detection: piston, lever, stalks, valves
- Angular position detection: knobs, jog wheels

3. Description

The MLX92352/1 is a monolithic sensor IC sensitive to magnetic field applied to X, Y and Z axes of the package. Any axes combination ZX, ZY, XY, XX, YY or ZZ on its open drain outputs is possible. It provides the customer ultimate configurability with its 90 degrees phase shift for a pitch independent magnetic design.

The device enables PCB-less module designs to save on your total cost of ownership without the need of external passive components. The MLX92352/1 withstands 15kV HBM, 8kV System ESD and it has high EMC robustness.

The MLX92352/1 can be programmed to act as magnetic latch, unipolar switch or omnipolar switch. The magnetic thresholds B_{OP} and B_{RP} can be programmed independently for each axis. Furthermore, the MLX92352/1 processes digitally the magnetic signal and outputs Speed, Direction or Pulse on its outputs.

The MLX92352/1 can be used to detect the rotation speed and direction of a ring magnet when configured as a dual magnetic latch. It can also switch on two independent magnet positions for complex position designs.

Customers can benefit from the end-of-line (EoL) programming capability of the MLX92352 to trim mechanical tolerances away or alternatively choose a pre-programmed MLX92351 device. Programming is available with the PTC04 or EVB2.

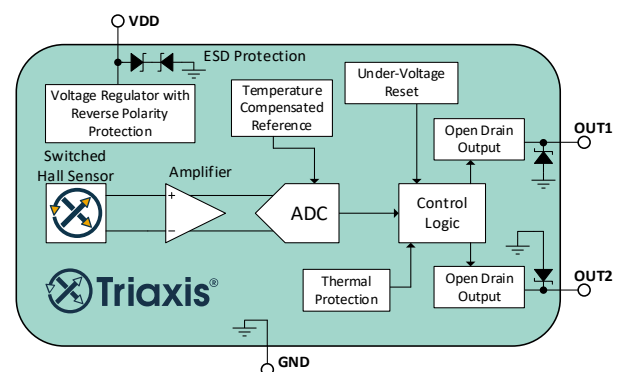

MLX92352/1 functional diagram

Contents

1. FEATURES AND BENEFITS	1
2. APPLICATION EXAMPLES	1
3. DESCRIPTION	1
4. ORDERING INFORMATION	3
5. PIN DEFINITIONS AND DESCRIPTIONS	4
5.1. Pin Definition for SE package	4
5.2. Pin Definition for VA package	4
6. GLOSSARY OF TERMS	5
7. ABSOLUTE MAXIMUM RATINGS	5
8. GENERAL ELECTRICAL SPECIFICATIONS	6
9. VERSION SPECIFIC PARAMETERS	8
9.1. MLX92352LVA-BAB-000-BU/ MLX92352LSE-BAA-000-BU	8
10. DETAILED DESCRIPTION	9
10.1. Start-Up feedback	9
10.2. Thermal protection function	10
10.3. Brownout reset function	10
10.4. Output functions	11
10.4.1. Speed/Speed	11
10.4.2. Speed/Direction	12
10.4.3. Pulse/Direction.....	12
11. MAGNETIC BEHAVIOR	14
11.1. Active magnetic pole definition	14
11.2. Latch Sensor	15
11.3. Unipolar Switch Sensor	15
11.4. Omnipolar Switch Sensor	16
11.5. Indexing magnet reference positions	17
11.5.1. TSOT-5L package.....	17
11.5.2. VA package.....	18
12. TYPICAL APPLICATION SCHEMATIC	19
13. PACKAGE INFORMATION	20
13.1. TSOT-5L (SE Package)	20
13.1.1. TSOT-5L – Package dimensions	20
13.1.2. TSOT-5L – Sensitive spot.....	20
13.1.3. TSOT-5L – Package marking.....	21
13.2. VA package	22
13.2.1. VA – Package dimensions	22
13.2.2. VA – Sensitive spot.....	22
13.2.3. VA – Package marking.....	23
14. STANDARD INFORMATION	24
14.1. Storage and handling of plastic encapsulated ICs	24
14.2. Assembly of encapsulated ICs	24
14.3. Environment and sustainability	24
15. ESD PRECAUTIONS	24
16. CONTACT	25
17. DISCLAIMER	25

MLX92352/MLX92351

3-Axis Programmable Hall Effect Latch/Switch
Datasheet

4. Ordering Information

Product	Temperature	Package	Option Code	Packing Form	Definition
MLX92352	L	VA	BAB-000	BU	Customer EoL programmable 4-wire sensor
MLX92352	L	SE	BAA-000	RE	Customer EoL programmable 4-wire sensor

Legend:

Product	MLX92351 – Factory Pre-Programmed 4-wire sensor MLX92352 – Customer EoL Programmable 4-wire sensor
Temperature Code:	L: T _A from -40°C to 150°C
Package Code:	“VA” for VA package “SE” for TSOT-5L
Option Code:	BAA = X/Y/Z-axis sensitive sensor BAB = Z/X-axis sensitive sensor BAC = Z/Y-axis sensitive sensor BAD = X/Y-axis sensitive sensor BAE = Z-axis sensitive sensor BAF = X-axis sensitive sensor BAG = Y-axis sensitive sensor
Packing Form:	BU: Bulk RE: Reel
Ordering Example:	MLX92352LVA-BAB-000-BU

MLX92352/MLX92351

3-Axis Programmable Hall Effect Latch/Switch
Datasheet

5. Pin Definitions and Descriptions

5.1. Pin Definition for SE package

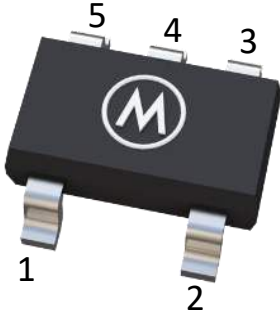

Pin #	Name	Description
1	OUT2	Open-Drain Output 2
2	OUT1	Open-Drain Output 1
3	VDD	Power Supply
4	GND	Ground pin
5	GND	Ground pin

Note: Both GND pins should be connected (pin 4 and pin 5)

5.2. Pin Definition for VA package

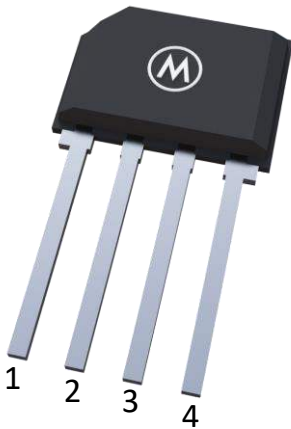

Pin #	Name	Description
1	OUT1	Open-Drain Output 1
2	VDD	Power Supply
3	GND	Ground pin
4	OUT2	Open-Drain Output 2

6. Glossary of Terms

Term	Definition
Gauss (G), Tesla (T)	Units for the magnetic flux density – 1 mT = 10 G
TC	Temperature Coefficient of the magnetic threshold (in ppm/°C)
ADC	Analog-to-Digital Converter
B _{OP}	Operating magnetic threshold
B _{RP}	Release magnetic threshold

7. Absolute Maximum Ratings

Parameter	Symbol	Value	Unit
Supply voltage ⁽¹⁾	V _{DD}	70	V
Reverse supply voltage ⁽¹⁾	V _{DDREV}	-40	V
Output voltage ⁽¹⁾	V _{OUT}	70	V
Reverse output voltage	V _{OUTREV}	-0.5	V
Output current	I _{OUT}	30	mA
Reverse output current	I _{OUTREV}	-50	mA
Maximum junction temperature ⁽²⁾	T _J	+175	°C
ESD – HBM ⁽³⁾	-	15	kV
ESD – CDM ⁽⁴⁾	-	1	kV
ESD – System ⁽⁵⁾	-	8	kV

Exceeding the absolute maximum ratings may cause permanent damage. Exposure to absolute maximum-rated conditions for extended periods may affect device reliability.

¹ For maximum 1 hour

² Guaranteed by 1000 hours HTOL

³ Human Body Model according AEC-Q100-002 standard

⁴ Charged Device Model according AEC-Q100-011 standard

⁵ Unpowered Contact discharge (150pF/330Ω), GND connected to the horizontal coupling plane, ISO10605

8. General Electrical Specifications

Operating conditions $V_{DD} = 2.7V$ to $60V$, $T_A = -40^{\circ}C$ to $150^{\circ}C$ (unless otherwise specified)

Electrical Parameter	Symbol	Condition	Min	Typ ⁽¹⁾	Max	Unit
Brownout reset threshold	V_{BOR}		–	–	2.6	V
Brownout duration	t_{BO}	²	–	–	1.4	s
Under Voltage Reset threshold	V_{UVR}		–	–	2.1	V
Under Voltage Reset reaction time ⁽³⁾	t_{UVR}	V_{DD} drop to 1.5V	–	1	–	μs
Output leakage	I_{OFF}	$V_{OUT} = 12V^{(3)}$	–	–	1	μA
		$V_{OUT} = 60V$	–	–	10	μA
Output saturation voltage	V_{OL}	$I_{OL} = 10mA^{(2)}$	–	0.15	0.4	V
		$I_{OL} = 20mA$	–	0.3	0.8	V
Output resistance	R_{OL}	$I_{OL} = 20mA$	–	15	40	Ω
Output rise time ^(3,4)	t_R	$R_{PU} = 4.7k\Omega$, $V_{DD} = 12V$, $V_{PU} = 5V$, $C_{LOAD} = 50pF$	0.3	0.5	1	μs
Output fall time ^(3,4)	t_F	$R_{PU} = 4.7k\Omega$, $V_{DD} = 12V$, $V_{PU} = 5V$, $C_{LOAD} = 50pF$	0.2	0.4	1	μs
Power-On time ^(5,6,7)	t_{ON}	$V_{DD} = 5V$, $\Delta V_{DD}/\Delta t \geq 2V/\mu s$ dual axis configuration	–	75	110	μs
		$V_{DD} = 5V$, $\Delta V_{DD}/\Delta t \geq 2V/\mu s$ single axis configuration	–	60	95	μs
		$V_{DD} = 5V$, $\Delta V_{DD}/\Delta t \geq 2V/\mu s$ dual axis configuration with Fast Start-Up enabled	–	60	95	μs
		$V_{DD} = 5V$, $\Delta V_{DD}/\Delta t \geq 2V/\mu s$ single axis configuration with Fast Start-Up enabled	–	50	75	μs

¹ Unless otherwise specified the typical values are defined at $T_A = +25^{\circ}C$ and $V_{DD} = 12V$

² Guaranteed by correlation with production test at $T_A = 150^{\circ}C$ and verified by characterization

³ Guaranteed by design and verified by characterization, not production tested

⁴ R_{PU} and V_{PU} are respectively the external pull-up resistor and pull-up power supply

⁵ The Power-On Time represents the time from reaching $V_{DD} = 2.7V$ to the first refresh of $OUT1$ and $OUT2$ state

⁶ Power-On Slew Rate is not critical for proper device start-up.

⁷ Using Fast Start-up option may add up to $\pm 2mT$ of additional offset for the first magnetic conversion.

MLX92352/MLX92351

3-Axis Programmable Hall Effect Latch/Switch
Datasheet

Electrical Parameter	Symbol	Condition	Min	Typ ⁽¹⁾	Max	Unit
Power-On state	–	Output state during t_{ON}	High			–
Maximum switching frequency ⁽²⁾	F_{SW_MAX}	Triangular magnetic field with $B_{PEAK} \geq 10 \times B_{OP}$; single axis, magnetic latch	37	42	–	kHz
		Triangular magnetic field with $B_{PEAK} \geq 10 \times B_{OP}$; dual axis, magnetic latch	21	24	–	kHz
Propagation delay ⁽²⁾	t_{PD}	Triangular magnetic field with $B_{PEAK} \geq 10 \times B_{OP}$, $F_B = 10 \text{kHz}$; single axis, magnetic latch	–	18	–	μs
		Triangular magnetic field with $B_{PEAK} \geq 10 \times B_{OP}$, $F_B = 10 \text{kHz}$; dual axis, magnetic latch	–	25	–	μs
Output jitter (p-p) ⁽²⁾	t_{JITTER}	Triangular magnetic field with $B_{PEAK} \geq 10 \times B_{OP}$, $F_B = 10 \text{kHz}$; single axis, magnetic latch	–	9	–	μs
		Triangular magnetic field with $B_{PEAK} \geq 10 \times B_{OP}$, $F_B = 10 \text{kHz}$; dual axis, magnetic latch	–	22	–	μs
Start-up feedback High-level input voltage	V_{SFB_IH}		1.4	–	–	V
Start-up feedback Low-level input voltage	V_{SFB_IL}		–	–	0.8	V
Supply current	I_{DD}		–	1.9	2.4	mA
Supply current in Thermal Protection	I_{DD_TPROT}		–	0.43	0.75	mA
Reverse supply current	I_{DDREV}	$V_{DD} = -30\text{V}$	-1	–	–	mA
Thermal Protection threshold	T_{PROT}		–	200	–	$^{\circ}\text{C}$
VA package thermal resistance	R_{THJA}	Single layer PCB, JEDEC standard test boards, still air (LFPM=0)	–	170	–	$^{\circ}\text{C/W}$
SE package thermal resistance	R_{THJA}	Single layer PCB, JEDEC standard test boards, still air (LFPM=0)	–	300	–	$^{\circ}\text{C/W}$

¹ Unless otherwise specified the typical values are defined at $T_A = +25^{\circ}\text{C}$ and $V_{DD} = 12\text{V}$

² Guaranteed by design and verified by characterization, not production tested

MLX92352/MLX92351

3-Axis Programmable Hall Effect Latch/Switch
Datasheet

9. Version Specific Parameters

9.1. MLX92352LVA-BAB-000-BU/ MLX92352LSE-BAA-000-BU

Operating conditions $V_{DD} = 2.7V$ to $60V$, $T_A = -40^{\circ}C$ to $150^{\circ}C$ (unless otherwise specified)

Magnetic Parameter	Symbol	Condition	Min	Typ ⁽¹⁾	Max	Unit
Operating point Output 1	B _{OP_OUT1}	T _A = -40°C	0.7	2	3.3	mT
		T _A = 25°C	1.1	2	2.9	
		T _A = 150°C	0.7	2	3.3	
Release point Output 1	B _{RP_OUT1}	T _A = -40°C	-3.3	-2	-0.7	mT
		T _A = 25°C	-2.9	-2	-1.1	
		T _A = 150°C	-3.3	-2	-0.7	
Operating point Output 2	B _{OP_OUT2}	T _A = -40°C	-3.3	-2	-0.7	mT
		T _A = 25°C	-2.9	-2	-1.1	
		T _A = 150°C	-3.3	-2	-0.7	
Release point Output 2	B _{RP_OUT2}	T _A = -40°C	0.7	2	3.3	mT
		T _A = 25°C	1.1	2	2.9	
		T _A = 150°C	0.7	2	3.3	
Temperature coefficient ⁽²⁾	TC			0		ppm/°C

	Sensitive axis	Magnetic function	Active pole	Output polarity	Output function	Direction pin polarity ⁽³⁾	Start-up feedback	Fast Start-up
Output 1	X	Latch	South	-	Speed	-	No	No
Output 2	Z	Latch	North	-	Speed			

¹ Unless otherwise specified the typical values are defined at $T_A = +25^{\circ}C$ and $V_{DD} = 12V$

² The Temperature Coefficient is calculated using following formula:

$$TC = \frac{B_{XPTA2} - B_{XPTA1}}{B_{XPTA1} \times (T_{A2} - T_{A1})} \times 10^6, ppm/^{\circ}C$$

where:

$$T_{A1} = 25^{\circ}C, T_{A2} = 150^{\circ}C$$

In case of magnetic Latch application: B_{XPTA1} (B_{XPTA2}) = B_{OP} - B_{RP} at T_{A1} (T_{A2})

In case of magnetic Switch application: B_{XPTA1} (B_{XPTA2}) = B_{OP} or B_{RP} at T_{A1} (T_{A2})

³ The Direction pin polarity is valid for the indexing magnet reference positions in chapter 11.5

10. Detailed Description

10.1. Start-Up feedback

The start-up feedback function essentially turns the two outputs into inputs during the Power-On time. After the elapse of t_{ON} the chip will use the externally provided state to set the references of the magnetic comparators to B_{OP} or B_{RP} for the corresponding magnetic axis. After t_{ON} the output state will correspond to the applied magnetic field. If the applied magnetic field is not leading to a change of the output state the state will remain the same as the one externally provided during power-on.

The Start-Up feedback function is particularly useful in applications where the power supply of the chip is controlled by an MCU. This function is enabling the possibility to recover the state of the chip to the last known state prior the power-down of the chip. The Start-Up feedback function can be enabled/disabled by the customers during end-of-line programming for MLX92352 or pre-programmed for MLX92351.

A typical application schematic is shown below.

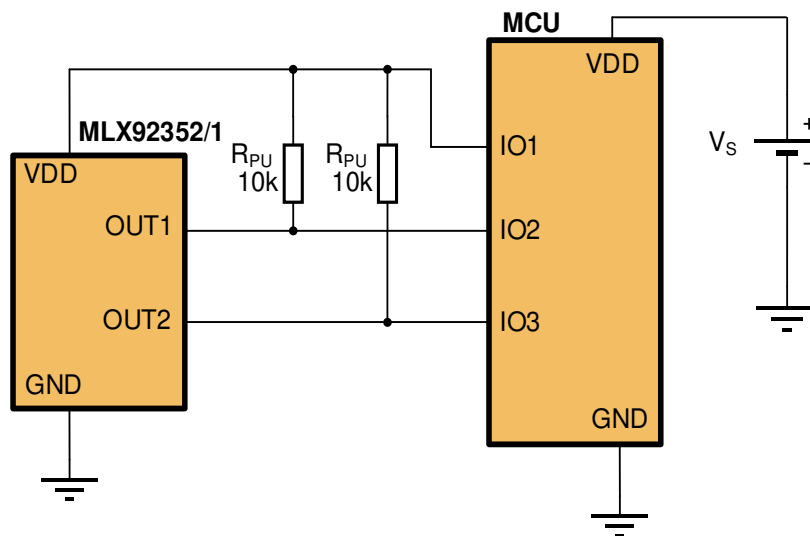

IO1 pin of the MCU should be a push-pull type. IO2 and IO3 pins should be open drain type in order to avoid an excessive current through the MCU's IO pins and MLX92352/1 outputs in case of output state conflict during t_{ON} . If open drain type of IO pins is not available, push-pull IO pins can be used with the following procedure. High state can be achieved by setting the IO pin to an input. For low state, the IO pin should be configured to an output with logic state low.

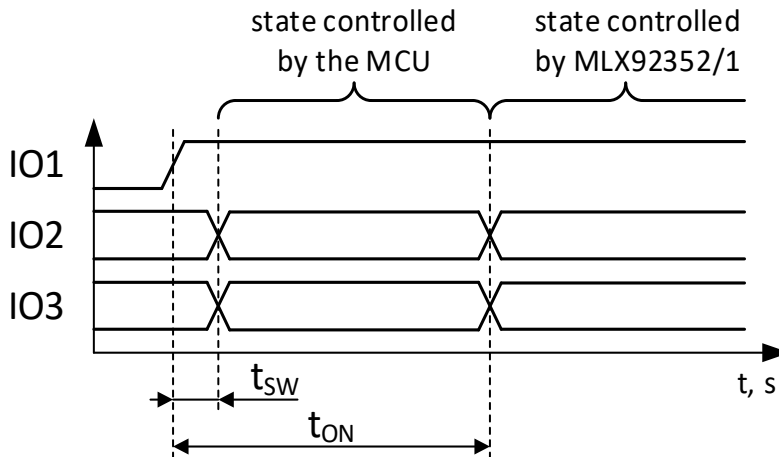

In the timing diagram above t_{SW} is the time from applying power to MLX92352/1 to providing a valid state on OUT1 and OUT2 from the MCU. This time should not exceed $10\mu s$, it can be zero or negative, there is no limit in this direction. Therefore, it is permitted to provide a valid Start-Up state to the chip before providing the supply voltage.

After t_{ON} , IO2 and IO3 pins should be switched to input and the state of the pins can be read. The state is controlled by MLX92352/1 after t_{ON} .

10.2. Thermal protection function

The Thermal Protection function is constantly monitoring the junction temperature (T_J) of the device. If T_J is higher than the Thermal Protection threshold (T_{PROT}) the current consumption of the device is reduced to I_{DD_TPROT} , both outputs are switched off and the magnetic measurements are disabled. Once T_J drops and stays below the T_{PROT} threshold for 200ms, the device resumes normal operation. The Thermal Protection function is used for overload protection of the outputs (e.g. short circuit to VDD).

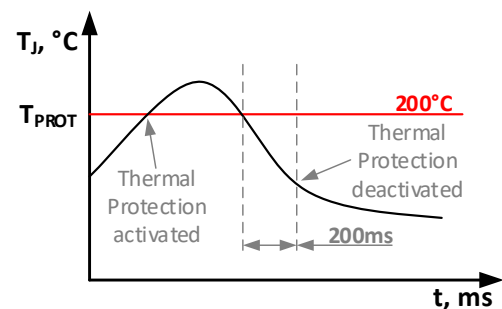

10.3. Brownout reset function

MLX92352/1 can tolerate a supply voltage drop below V_{BOR} , but above V_{UVR} , for a limited amount of time t_{BO} without resetting. If t_{BO} is exceeded, the device will enter reset state. In order for the device to exit the reset state the V_{DD} should be higher than V_{BOR} . If the supply voltage drops below V_{UVR} for more than t_{UVR} the MLX92352/1 is reset.

MLX92352/MLX92351

3-Axis Programmable Hall Effect Latch/Switch
Datasheet

10.4. Output functions

The MLX92352/1 can provide to its outputs unprocessed result from the comparison of the applied magnetic field and the pre-programmed magnetic thresholds. This type of output function is called Speed/Speed.

The chip can also provide to its outputs processed versions of the magnetic signal called Speed/Direction and Pulse/Direction. These functions are using the result from the magnetic comparison and further processing it to extract the information for the rotation direction.

Speed/Speed, Speed/Direction and Pulse/Direction output functions are typically used with magnetic Latch configuration.

The output functions can be configured by the user for MLX92352 or by Melexis for MLX92351 versions.

10.4.1. Speed/Speed

The effect of the Speed/Speed function over the output behavior is demonstrated on the diagram below. It is shown how the state of the outputs is changing in relation to the position of the magnet for this particular configuration (Z/X, South Pole active Latch). In Speed/Speed mode the MLX92352/1 effectively outputs a quadrature signal. The direction of the rotation/movement, the position (number of poles passed by) and the speed of the rotation/movement of the magnet can be extracted using further analysis of the signal from the two outputs.

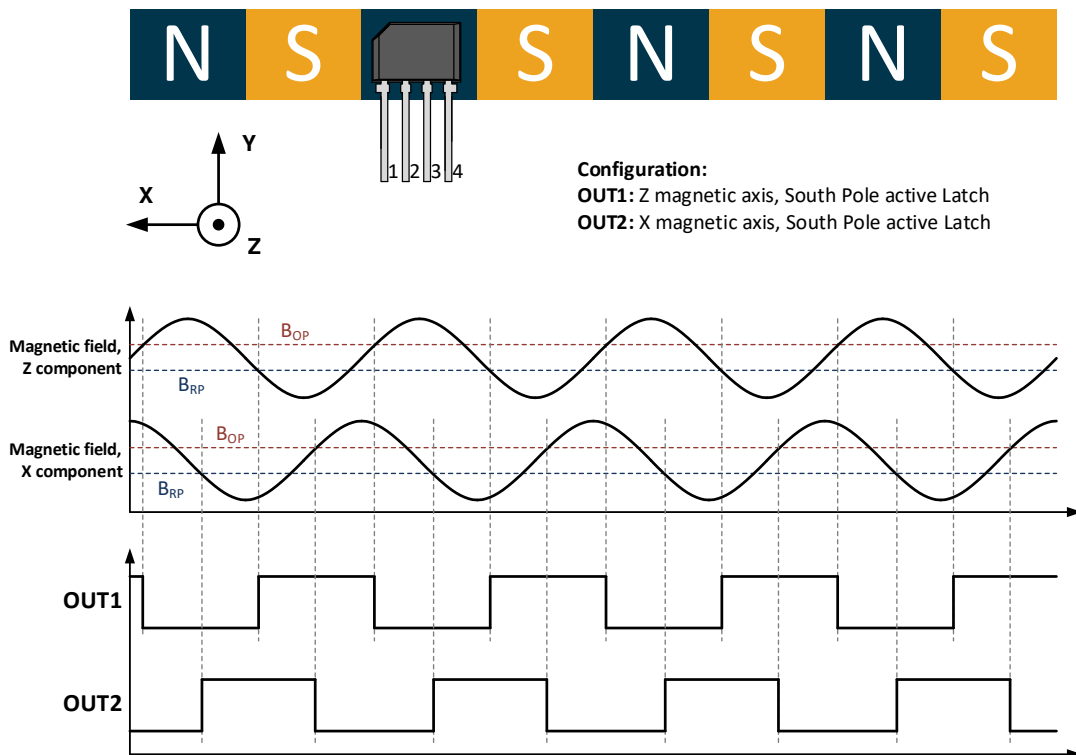

The MLX92352/1 provides the flexibility to assign the two outputs to any magnetic axis with arbitrary magnetic thresholds for each axis, including arbitrary combination of South Pole and North Pole active Latch.

10.4.2. Speed/Direction

The Speed/Direction functionality is shown on the diagram below. The chip is using one of the magnetic axis to output the Speed signal. The Speed signal is typically used to count the number of pole-pairs passed by the chip and the rotational/linear speed of the magnet. The Direction signal is generated using both magnetic axis in order to evaluate the direction of the movement of the magnet.

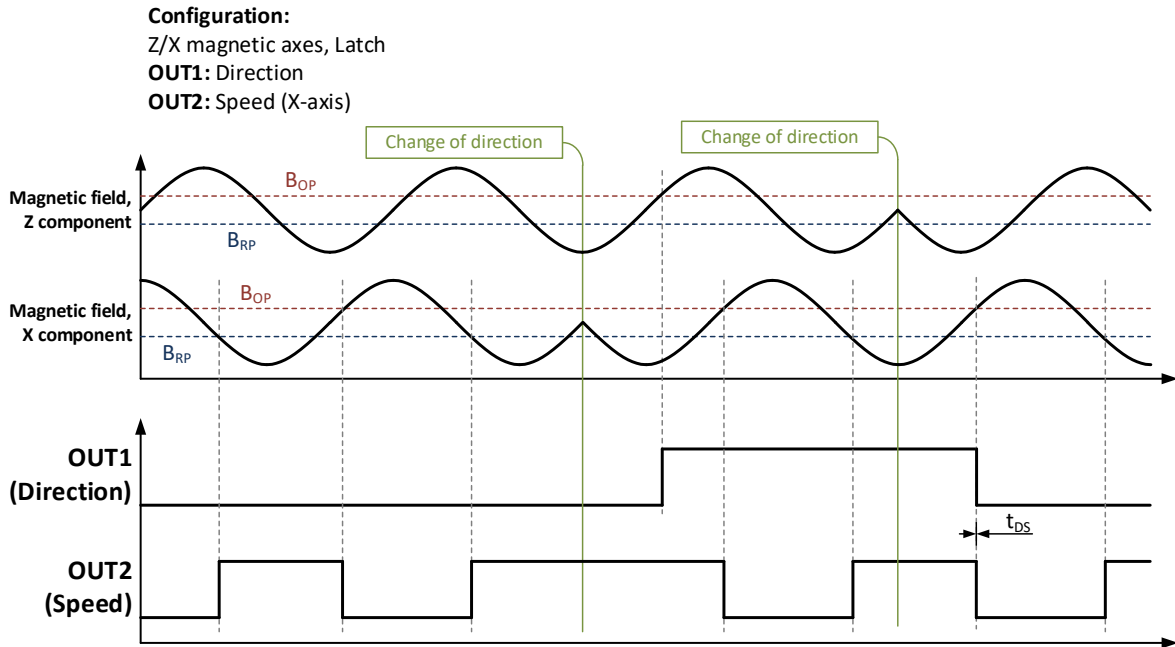

The Speed and Direction signals can be inverted independently. Similar to Speed/Speed an arbitrary combination of magnetic axis can be configured for Speed/Direction function. Speed and Direction signals can be assigned to any of the two outputs. The Direction signal is always updated before the Speed signal. The delay of the Speed signal with respect to the Direction signal (t_{DS}) is typically $4\mu s$.

10.4.3. Pulse/Direction

The Pulse/Direction functionality is demonstrated on the diagram below. The major difference between Pulse/Direction and Speed/Direction is the usage of both magnetic axes to generate the Pulse signal. In this way, two times the angular/linear resolution is achieved with the same magnet versus the Speed/Direction function. The Pulse signal is typically used to count the number of poles passed by the chip and the rotational/linear speed of the magnet. The Direction signal is generated using both magnetic axis in order to evaluate the direction of the movement of the magnet.

MLX92352/MLX92351

3-Axis Programmable Hall Effect Latch/Switch
Datasheet

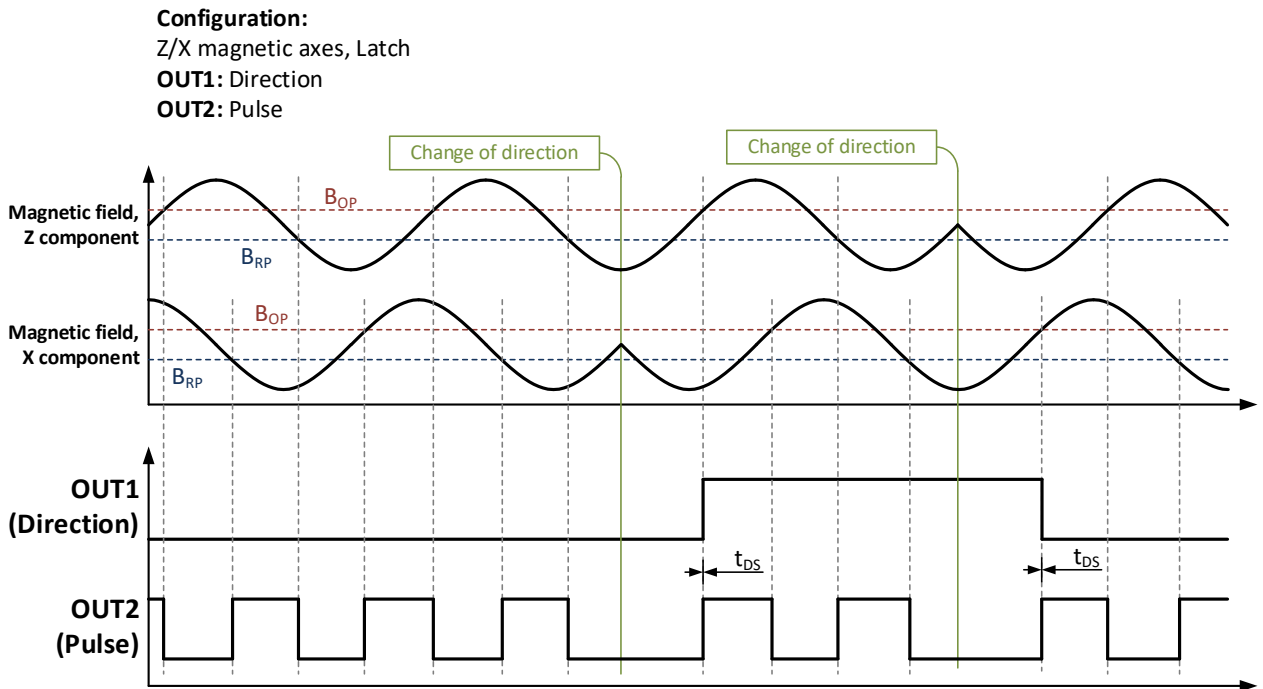

The Pulse and Direction signals can be inverted independently. Similar to Speed/Speed an arbitrary combination of magnetic axis can be configured for Pulse/Direction function. Pulse and Direction signals can be assigned to any of the two outputs. The Direction signal is always updated before the Pulse signal. The delay of the Pulse signal with respect to the Direction signal (t_{DS}) is typically $4\mu s$.

MLX92352/MLX92351

3-Axis Programmable Hall Effect Latch/Switch
Datasheet

11. Magnetic Behavior

The MLX92352/1 can be programmed to act as magnetic Latch, Unipolar Switch or Omnipolar Switch. The magnetic function, thresholds and active magnetic axis can be programmed individually for each output. The magnetic behavior can be configured by the user for MLX92352 or by Melexis for MLX92351 versions.

11.1. Active magnetic pole definition

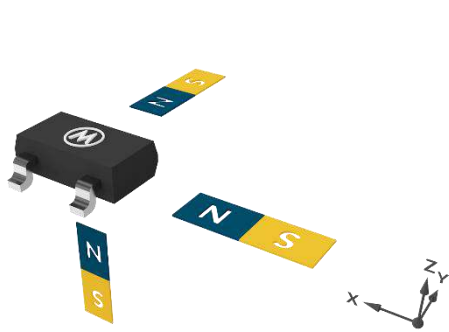

SE package
North Pole Active for X,Y and Z axis

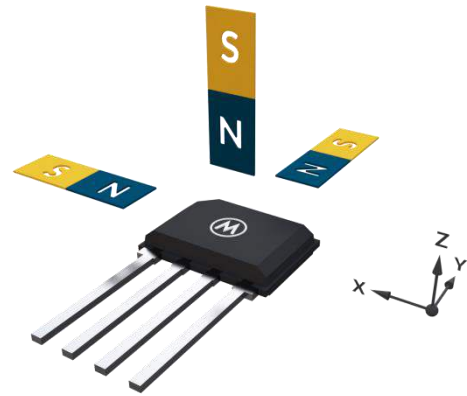

VA package
North Pole Active for X,Y and Z axis

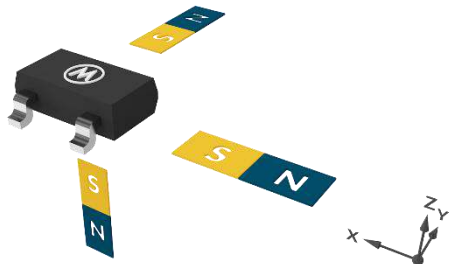

SE package
South Pole Active for X,Y and Z axis

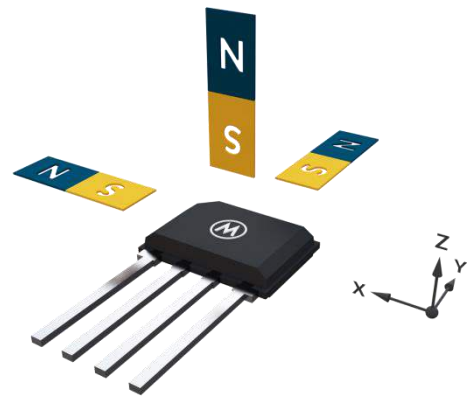

VA package
South Pole Active for X,Y and Z axis

11.2. Latch Sensor

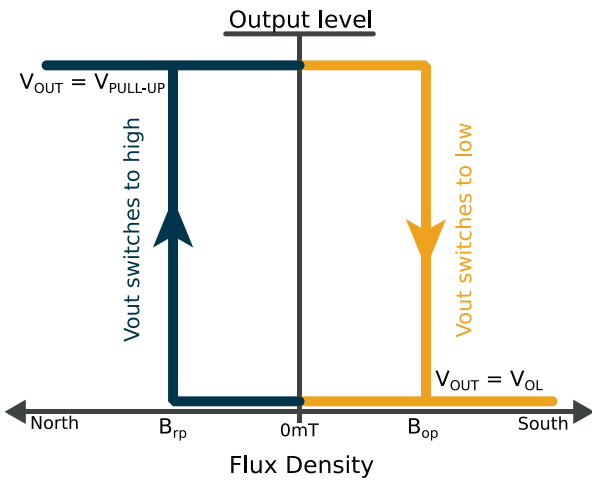

South Pole Active Latch

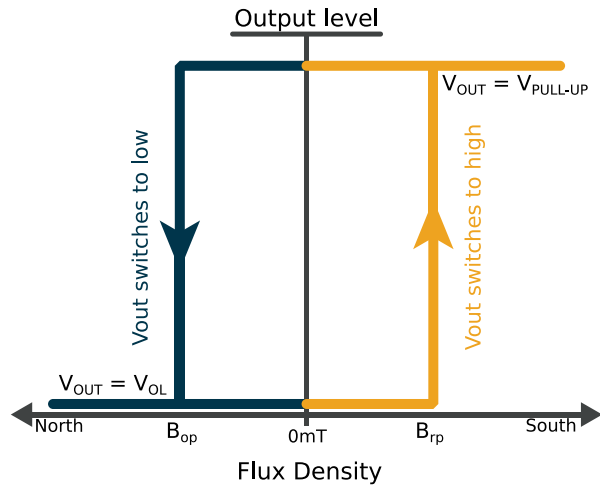

North Pole Active Latch

11.3. Unipolar Switch Sensor

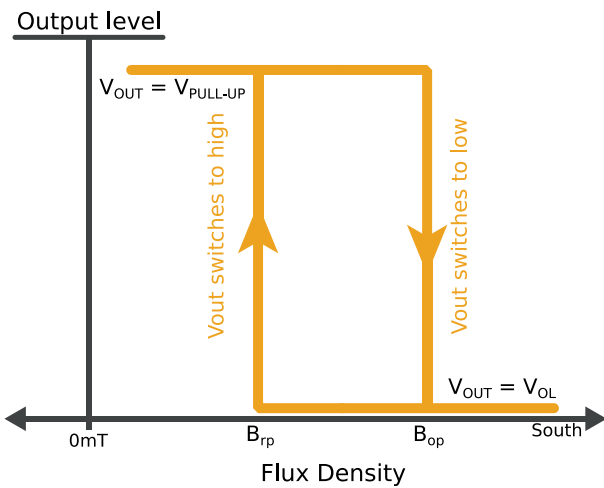

Direct South Pole Active Switch

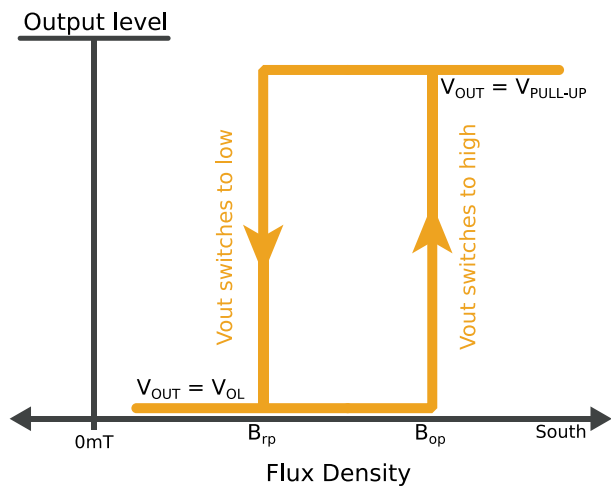

Inverted South Pole Active Switch

MLX92352/MLX92351

3-Axis Programmable Hall Effect Latch/Switch
Datasheet

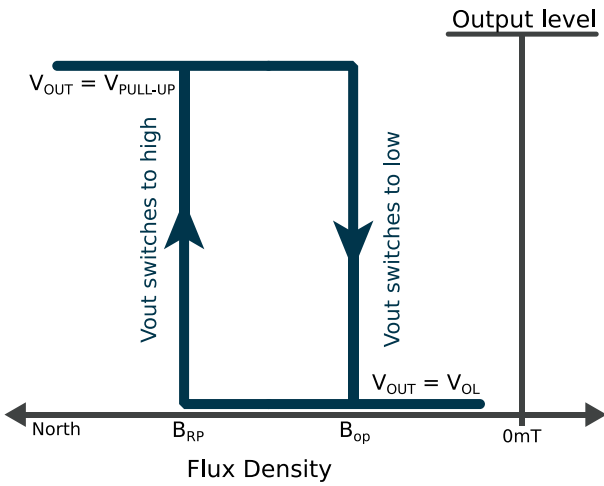

Direct North Pole Active Switch

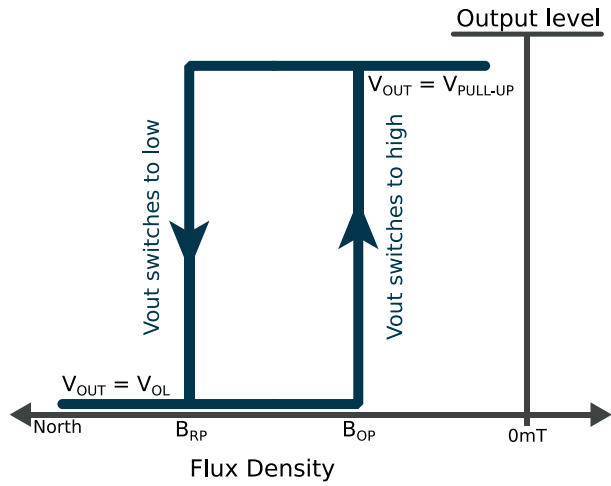

Inverted North Pole Active Switch

11.4. Omnipolar Switch Sensor

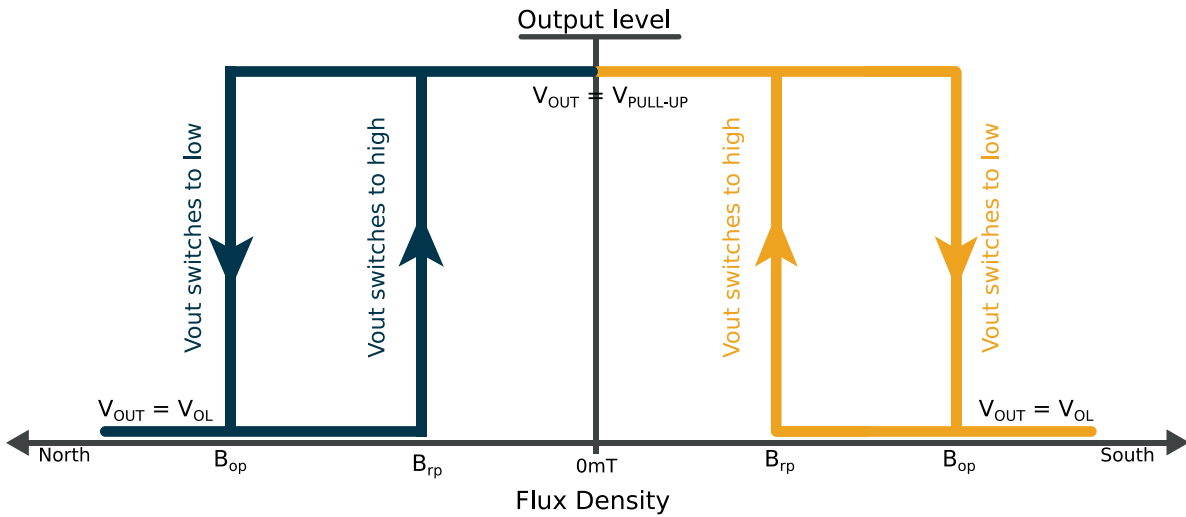

Direct Omnipolar Switch

MLX92352/MLX92351

3-Axis Programmable Hall Effect Latch/Switch
Datasheet

11.5. Indexing magnet reference positions

11.5.1. TSOT-5L package

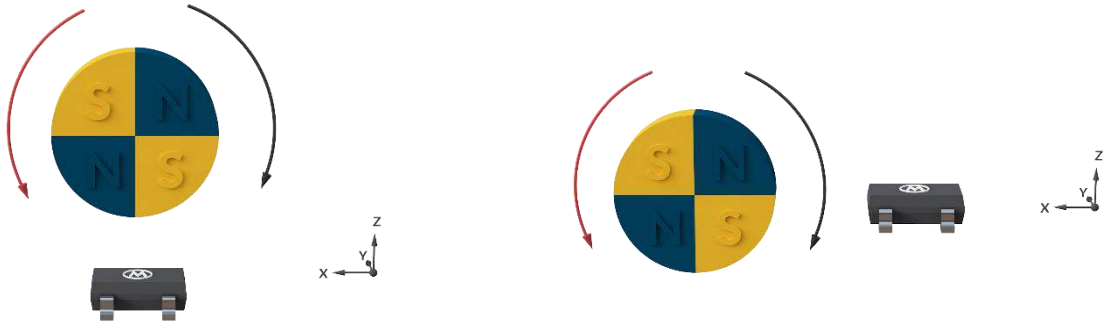

ZX configuration

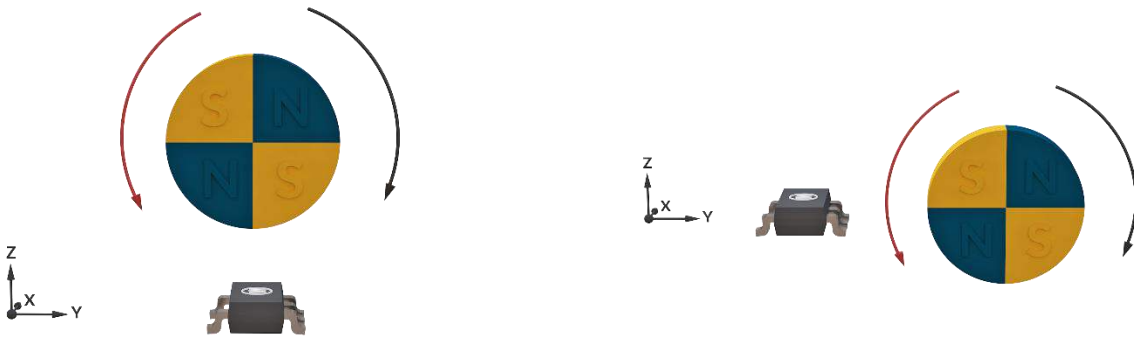

ZY configuration

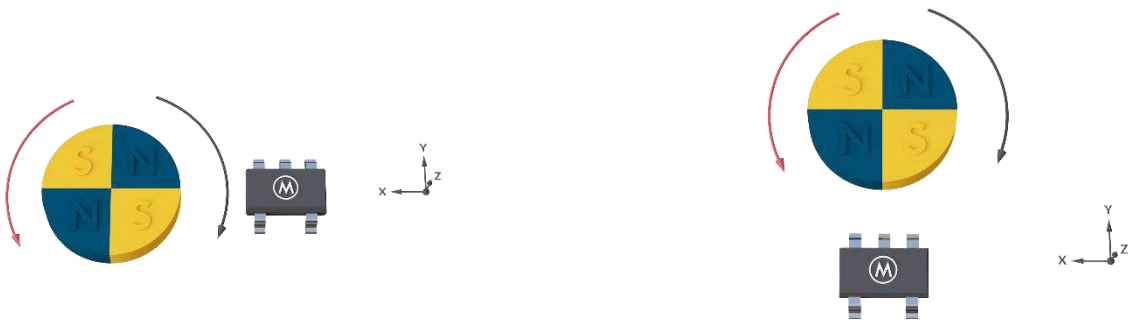

XY configuration

MLX92352/MLX92351

3-Axis Programmable Hall Effect Latch/Switch
Datasheet

11.5.2. VA package

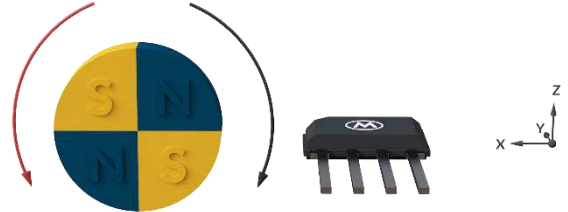
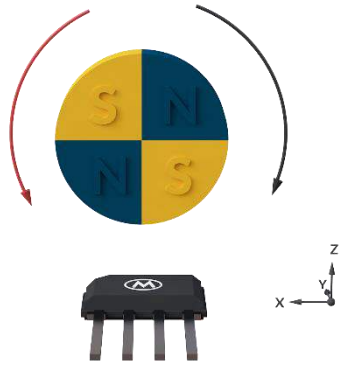

ZX configuration

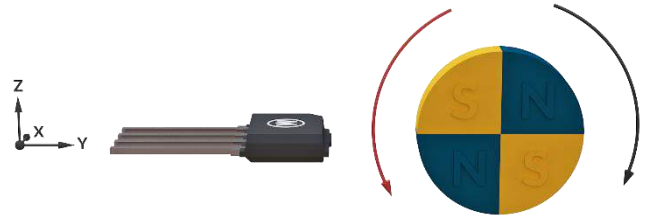
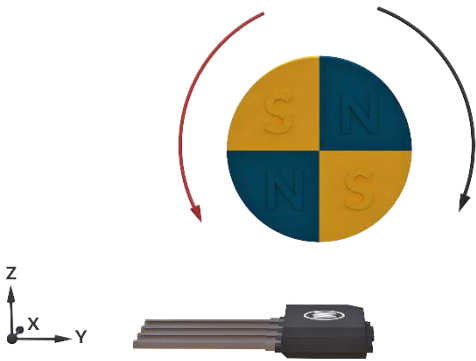

ZY configuration

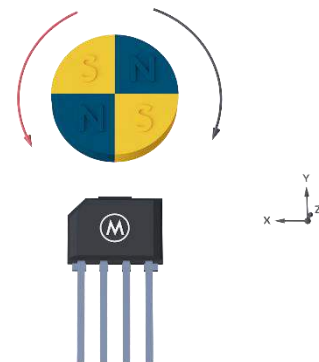
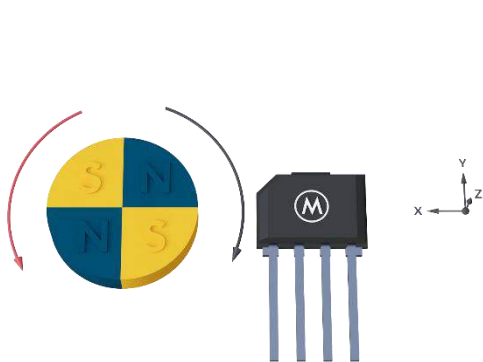

XY configuration

MLX92352/MLX92351

3-Axis Programmable Hall Effect Latch/Switch
Datasheet

12. Typical Application Schematic

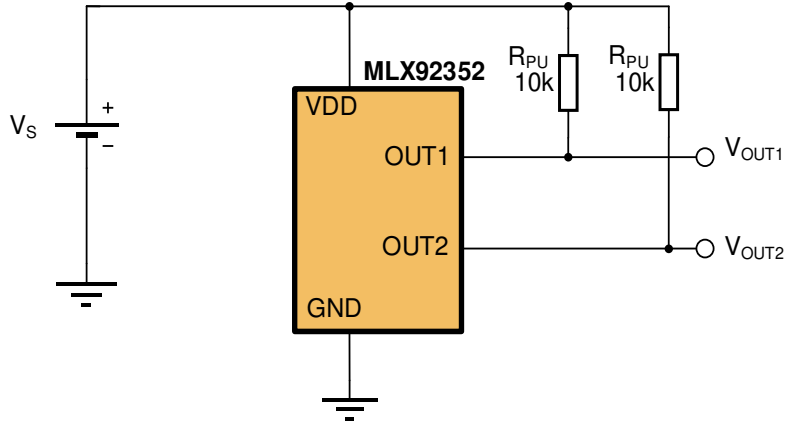

MLX92352/MLX92351

3-Axis Programmable Hall Effect Latch/Switch
Datasheet

13. Package Information

13.1. TSOT-5L (SE Package)

13.1.1. TSOT-5L – Package dimensions

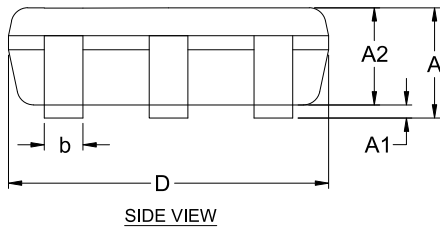
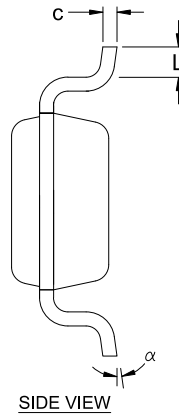
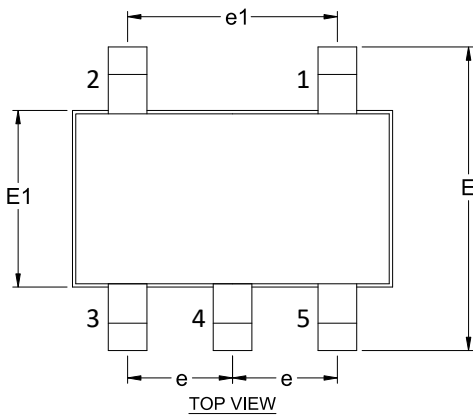

SYMBOL	MINIMUM	MAXIMUM
A	---	1.00
A1	0.025	0.10
A2	0.85	0.90
D	2.80	3.00
E	2.60	3.00
E1	1.50	1.70
L	0.30	0.50
b	0.30	0.45
c	0.10	0.20
e	0.95 BSC	
e1	1.90 BSC	
α	0°	8°

NOTE :

1. ALL DIMENSIONS IN MILLIMETERS (mm) UNLESS OTHERWISE STATED.
2. DIMENSION D DOES NOT INCLUDE MOLD FLASH OR PROTRUSIONS OF MAX 0.15 mm PER SIDE.
3. DIMENSION E DOES NOT INCLUDE MOLD FLASH OR PROTRUSIONS OF MAX 0.25 mm PER SIDE.
4. DIMENSION b DOES NOT INCLUDE DAMBAR PROTRUSION OF MAX 0.07 mm.
5. DIMENSION L IS THE LENGTH OF THE TERMINAL FOR SOLDERING TO A SUBSTRATE.
6. FORMED LEAD SHALL BE PLANAR WITH RESPECT TO ONE ANOTHER WITH 0.076 mm SEATING PLANE.

13.1.2. TSOT-5L – Sensitive spot

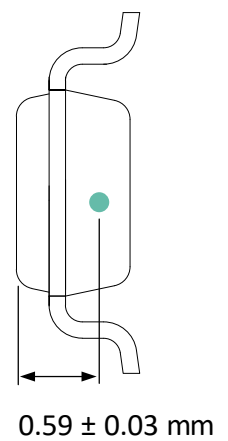
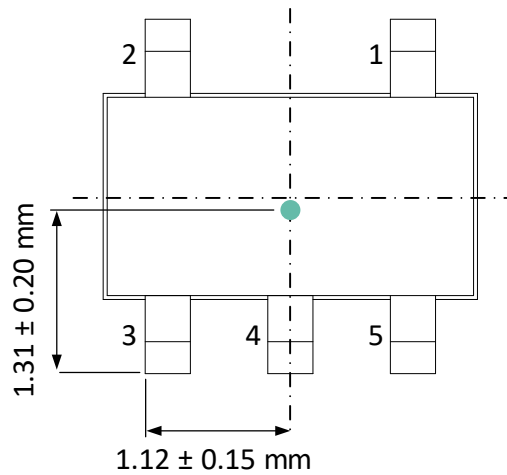
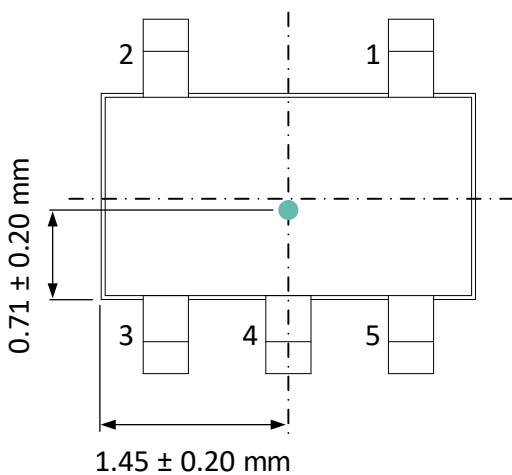

MLX92352/MLX92351

3-Axis Programmable Hall Effect Latch/Switch
Datasheet

13.1.3. TSOT-5L – Package marking

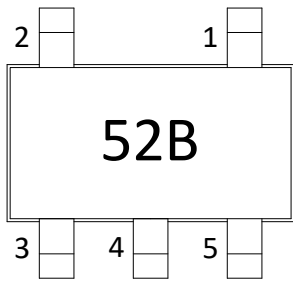

Top

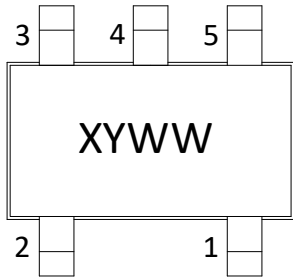
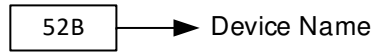

Bottom

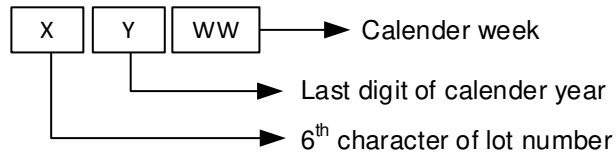

MLX92352/MLX92351

3-Axis Programmable Hall Effect Latch/Switch
 Datasheet

13.2. VA package

13.2.1. VA – Package dimensions

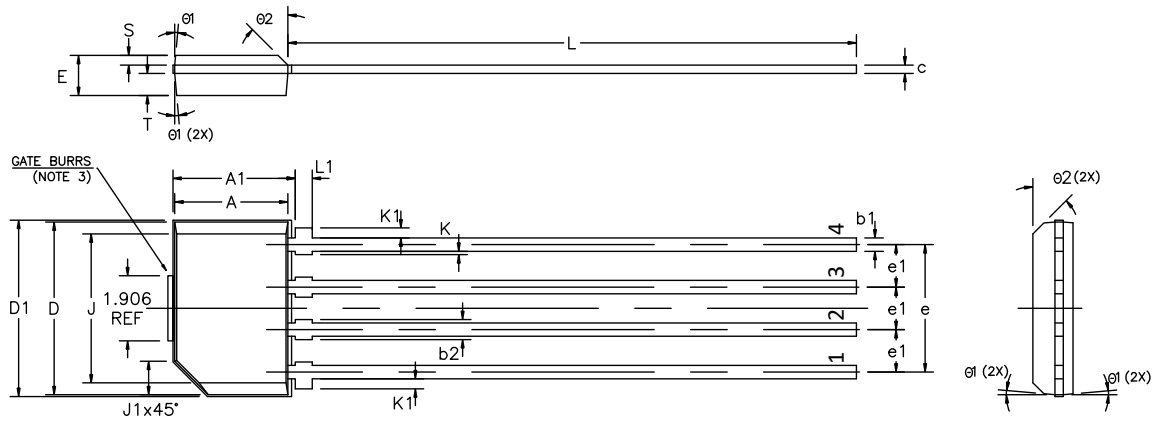

SYMBOLS	DIMENSIONS IN MILLIMETERS		
	MIN	NOM	MAX
A	3.30	3.38	3.46
A1	3.63	3.71	3.79
D	5.08	5.16	5.24
D1	5.33	5.38	5.43
E	1.10	----	1.20
J	4.10	4.30	4.50
J1	1.00 REF		
K	0.00	----	0.15
K1	0.25	0.30	0.35
L	17.5	18.0	18.5
L1	0.48	0.53	0.58
S	0.24	----	0.29
T	0.61	----	0.66
b1	0.35	----	0.48
b2	0.40	----	0.60
c	0.18	----	0.34
e	3.76	----	3.86
e1	1.22	1.27	1.32
$\theta 1$	5° REF		
$\theta 2$	45° REF		

Note:

1. DIMENSIONS "A" AND "D" DO NOT INCLUDE MOLD FLASH, PROTRUSIONS AND GATE BURRS.
2. DIMENSIONS "A1" DOES NOT INCLUDE GATE BURRS BUT INCLUDES MOLD FLASH AT BOTH ENDS.
3. MOLD GATE BURRS SHALL NOT EXCEED 0.15 mm MEASURED FROM EDGE OF MOLD FLASH (FLANGE).
4. DIMENSION "D1" INCLUDES MOLD FLASH AT BOTH ENDS.
5. LEAD PLATING; MATTE TIN PLATING THICKNESS 7.62 – 15.42 μ m.
6. THE LEADS MAY BE SLIGHTLY DEFORMED DURING TRANSPORTATION IF PACKED IN BULK (BAG), AFFECTING e1 DIMENSION. IT IS RECOMMENDED TO ORDER RADIAL TAPE (REEL OR AMMOPACK) IF SUCH DEFORMATION IS CRITICAL FOR THE LEAD FORMING PROCESS, EVEN IF MANUAL LOADING INTO THE TOOL IS FORESEEN.

13.2.2. VA – Sensitive spot

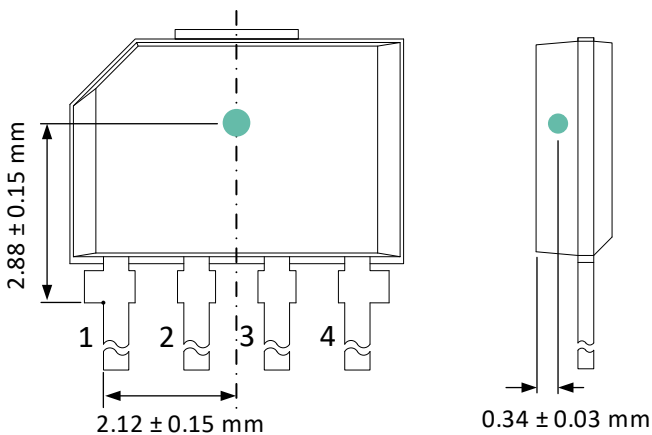

MLX92352/MLX92351

3-Axis Programmable Hall Effect Latch/Switch
Datasheet

13.2.3. VA – Package marking

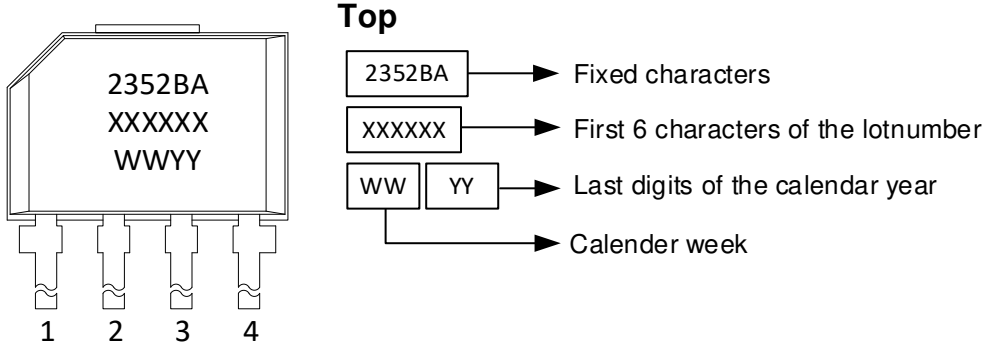

14. Standard Information

14.1. Storage and handling of plastic encapsulated ICs

Plastic encapsulated ICs shall be stored and handled according to their MSL categorization level (specified in the packing label) as per J-STD-033.

Electronic semiconductor products are sensitive to Electro Static Discharge (ESD). The component assembly shall be handled in EPA (Electrostatic Protected Area) as per ANSI S20.20.

For more information refer to Melexis [Guidelines for storage and handling of plastic encapsulated ICs](#) ⁽¹⁾

14.2. Assembly of encapsulated ICs

For Surface Mounted Devices (SMD, as defined according to JEDEC norms), the only applicable soldering method is reflow.

For Through Hole Devices (THD), the applicable soldering methods are reflow, wave, selective wave and robot point-to-point. THD lead pre-forming (cutting and/or bending) is applicable under strict compliance with Melexis [Guidelines for lead forming of SIP Hall Sensors](#) ⁽¹⁸⁾.

Melexis products soldering on PCB should be conducted according to the requirements of IPC/JEDEC and J-STD-001. Solder quality acceptance should follow the requirements of IPC-A-610.

For PCB-less assembly refer to the relevant application notes ⁽¹⁸⁾ or contact Melexis.

Electrical resistance welding or laser welding can be applied to Melexis products in THD and specific PCB-less packages following the [Guidelines for welding of PCB-less devices](#) ⁽¹⁸⁾.

Environmental protection of customer assembly with Melexis products for harsh media application, is applicable by means of coating, potting or overmolding considering restrictions listed in the relevant application notes ⁽¹⁸⁾.

For other specific process, contact Melexis via www.melexis.com/technical-inquiry

14.3. Environment and sustainability

Melexis is contributing to global environmental conservation by promoting non-hazardous solutions. For more information on our environmental policy and declarations (RoHS, REACH...) visit www.melexis.com/environmental-forms-and-declarations

15. ESD Precautions

Electronic semiconductor products are sensitive to Electro Static Discharge (ESD). Always observe Electro Static Discharge control procedures whenever handling semiconductor products.

¹ www.melexis.com/ic-handling-and-assembly

16. Contact

For the latest version of this document, go to our website at www.melexis.com.

For additional information, get in touch via www.melexis.com/contact.

17. Disclaimer

The content of this document is believed to be correct and accurate. However, the content of this document is furnished "as is" for informational use only and no representation, nor warranty is provided by Melexis about its accuracy, nor about the results of its implementation. Melexis assumes no responsibility or liability for any errors or inaccuracies that may appear in this document. Customer will follow the practices contained in this document under its sole responsibility. This documentation is in fact provided without warranty, term, or condition of any kind, either implied or expressed, including but not limited to warranties of merchantability, satisfactory quality, non-infringement, and fitness for purpose. Melexis, its employees and agents and its affiliates' and their employees and agents will not be responsible for any loss, however arising, from the use of, or reliance on this document. Notwithstanding the foregoing, contractual obligations expressly undertaken in writing by Melexis prevail over this disclaimer.

This document is subject to change without notice, and should not be construed as a commitment by Melexis. Therefore, before placing orders or prior to designing the product into a system, users or any third party should obtain the latest version of the relevant information.

Users or any third party must determine the suitability of the product described in this document for its application, including the level of reliability required and determine whether it is fit for a particular purpose.

This document as well as the product here described may be subject to export control regulations. Be aware that export might require a prior authorization from competent authorities. The product is not designed, authorized or warranted to be suitable in applications requiring extended temperature range and/or unusual environmental requirements. High reliability applications, such as medical life-support or life-sustaining equipment or avionics application are specifically excluded by Melexis. The product may not be used for the following applications subject to export control regulations: the development, production, processing, operation, maintenance, storage, recognition or proliferation of:

- 1. chemical, biological or nuclear weapons, or for the development, production, maintenance or storage of missiles for such weapons;*
- 2. civil firearms, including spare parts or ammunition for such arms;*
- 3. defense related products, or other material for military use or for law enforcement;*
- 4. any applications that, alone or in combination with other goods, substances or organisms could cause serious harm to persons or goods and that can be used as a means of violence in an armed conflict or any similar violent situation.*

No license nor any other right or interest is granted to any of Melexis' or third party's intellectual property rights.

If this document is marked "restricted" or with similar words, or if in any case the content of this document is to be reasonably understood as being confidential, the recipient of this document shall not communicate, nor disclose to any third party, any part of the document without Melexis' express written consent. The recipient shall take all necessary measures to apply and preserve the confidential character of the document. In particular, the recipient shall (i) hold document in confidence with at least the same degree of care by which it maintains the confidentiality of its own proprietary and confidential information, but no less than reasonable care; (ii) restrict the disclosure of the document solely to its employees for the purpose for which this document was received, on a strictly need to know basis and providing that such persons to whom the document is disclosed are bound by confidentiality terms substantially similar to those in this disclaimer; (iii) use the document only in connection with the purpose for which this document was received, and reproduce document only to the extent necessary for such purposes; (iv) not use the document for commercial purposes or to the detriment of Melexis or its customers. The confidentiality obligations set forth in this disclaimer will have indefinite duration and in any case they will be effective for no less than 10 years from the receipt of this document.

This disclaimer will be governed by and construed in accordance with Belgian law and any disputes relating to this disclaimer will be subject to the exclusive jurisdiction of the courts of Brussels, Belgium.

The invalidity or ineffectiveness of any of the provisions of this disclaimer does not affect the validity or effectiveness of the other provisions. The previous versions of this document are repealed.

Melexis © - No part of this document may be reproduced without the prior written consent of Melexis. (2022)

IATF 16949 and ISO 14001 Certified