

A-1840-6-4 SHOWN

PART NO.	ENGINEERING NO.	TERMINAL PATTERN					
		1	2	3	4	5	6
09-18-5061	A-1840-6-4	M	M	M	M	M	F
09-18-5062	A-1840-6-5	M	M	M	M	F	M
09-18-5064	A-1840-6-6	M	M	M	F	M	M
09-18-5069	A-1840-6-10	F	M	M	M	M	M

- MATERIAL:
BASE AND RECEPTACLE: NYLON PA66 PER 68200-0037, UL94V-2. COLOR: NATURAL
TERMINALS: MALE - C26000 ALLOY BRASS
FEMALE - C51000 PHOS. BRONZE
- FINISH:
999 - UNPLATED
102 - (MALE TERMINALS ONLY)
.000200/0.00508 MIN. TIN OVER
.000100/0.00254 MIN. COPPER
126 - (FEMALE TERMINALS ONLY)
.000050/0.00127 MIN. TIN
.000050/0.00127 MIN. NICKEL
- PRODUCT SPECIFICATION: N/A
- PACKAGING SPECIFICATION: PK-1840-001
- POLARIZATION ACCOMPLISHED THROUGH AN INTER-MIX OF MALE AND FEMALE TERMINALS. (MOLEX .093 TERMINALS)
- TERMINAL PATTERN CODE:
M = MALE TERMINALS
F = FEMALE TERMINALS
B = NO TERMINALS

ADD PKG SPECS EC NO: UCP2013-4695 DRW: AELHAG 2013/05/01 CHKD: JEBELL 2013/05/01 APPR: FSMITH 2013/05/13	QUALITY SYMBOLS ▽=0 ▽=0 ▽=1	GENERAL TOLERANCES (UNLESS SPECIFIED)		DIMENSION STYLE IN/MM	SCALE 6:1	DESIGN UNITS INCH	THIRD ANGLE PROJECTION	
		4 PLACES ± --- ± ---	DRAWN BY EWC	DATE 1974/04/30	CONNECTOR PC BOARD WAFERCON 6 CIRCUIT			
		3 PLACES ± --- ± .005	CHECKED BY JBELL	DATE 2013/05/01				
		2 PLACES ± 0.13 ± .010	APPROVED BY FSMITH		DATE 2011/09/14	MOLEX INCORPORATED MATERIAL NO. 1840-6-* DOCUMENT NO.		
1 PLACE ± 0.25 ± ---	DRAFT WHERE APPLICABLE MUST REMAIN WITHIN DIMENSIONS		SEE CHART	SHEET NO. 1 OF 1				

THIS DRAWING CONTAINS INFORMATION THAT IS PROPRIETARY TO MOLEX INCORPORATED AND SHOULD NOT BE USED WITHOUT WRITTEN PERMISSION

PART NO.	ENG. NO.	TERMINAL PATTERN								
		1	2	3	4	5	6	7	8	9
09-18-5094	A-1840-9-12	F	M	M	M	M	M	M	M	M
09-18-5098	A-1840-9-5	F	M	M	M	M	M	F	M	M

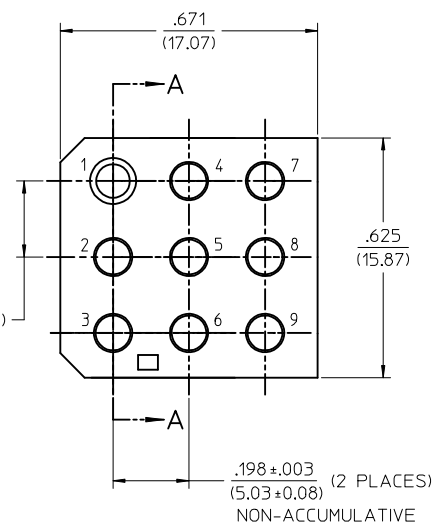
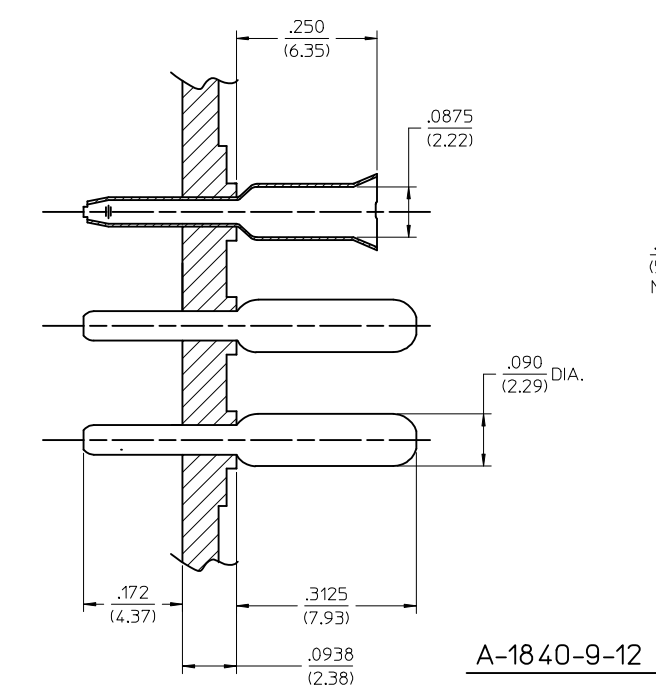
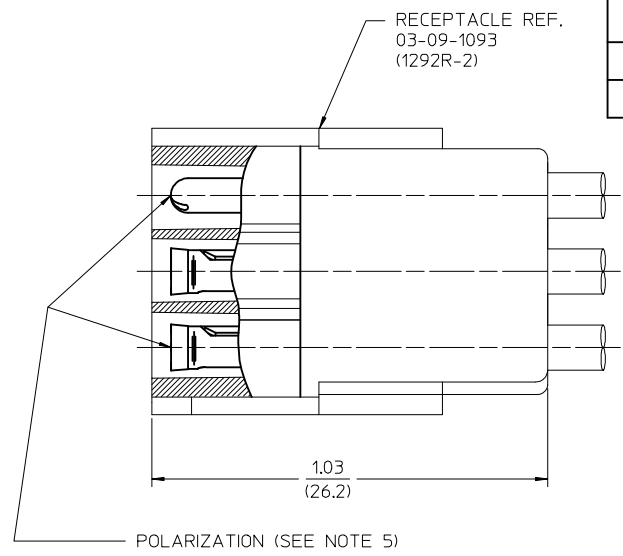
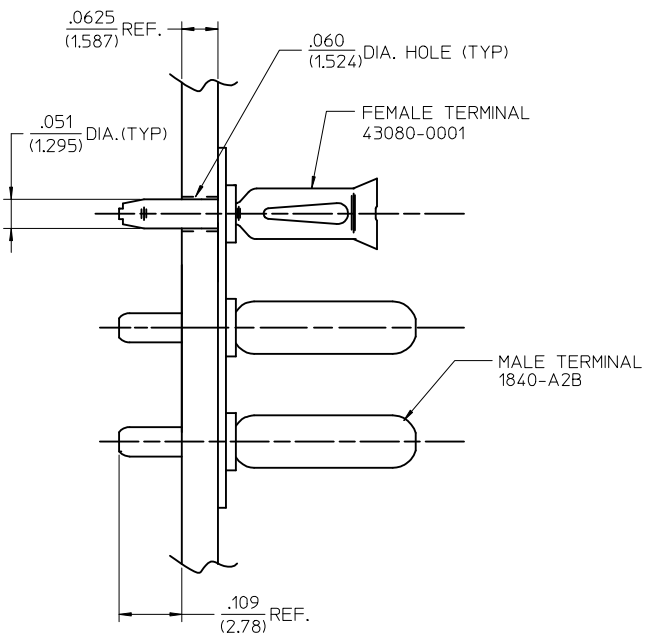

- NOTES:
- MATERIAL:
BASE AND RECEPTACLE: NYLON PA66, UL94V-0, COLOR: NATURAL
TERMINALS: MALE - BRASS ALLOY
FEMALE - PHOSPHOR BRONZE ALLOY
 - FINISH:
MALE TERMINALS: .000200/0.00508 MIN. TIN OVER
.000100/0.00254 MIN. COPPER
FEMALE TERMINALS: .000050/0.00127 MIN. TIN OVER
.000050/0.00127 MIN. NICKEL
 - PRODUCT SPECIFICATION: N/A
 - PACKAGING SPECIFICATION: PK-1840-001
 - POLARIZATION ACCOMPLISHED THROUGH AN INTER-MIX OF MALE AND FEMALE TERMINALS. (MOLEX .093 TERMINALS)
 - TERMINAL PATTERN CODE:
A) M = MALE TERMINALS
B) F = FEMALE TERMINALS
C) B = NO TERMINALS
 - PARTS TO BE MOUNTED ON SUPPORTED EDGE OF P.C. BOARD.

SCALE: 4:1

A-1840-9-12 SHOWN

SECTION "A-A"

ADD PKG SPECS EC NO: UCP2013-4695 DRW: NAE/HAG CHKD: JBELL APPR: FSM/TH 2013/05/01 2013/05/01 2013/05/13	QUALITY SYMBOLS	GENERAL TOLERANCES (UNLESS SPECIFIED)	DIMENSION STYLE	SCALE	DESIGN UNITS	THIRD ANGLE PROJECTION	
	▽=0	mm INCH	IN/MM	6:1	INCH		
	▽=0	4 PLACES ± --- ± ---	DRAWN BY DATE	EWC	1974/04/30	CONNECTOR PC BOARD WAFERCON 9 CIRCUIT	
	▽=0	3 PLACES ± --- ± .005	CHECKED BY DATE	JBELL	2013/05/01	MOLEX INCORPORATED	
		2 PLACES ± 0.13 ± .010	APPROVED BY DATE	FSM/TH	2011/09/14	SDA-1840-9-*	
		1 PLACE ± 0.25 ± ---	MATERIAL NO.	SEE CHART	DOCUMENT NO.	SHEET NO.	
		ANGULAR ±1/2°				1 OF 1	
		DRAFT WHERE APPLICABLE MUST REMAIN WITHIN DIMENSIONS	THIS DRAWING CONTAINS INFORMATION THAT IS PROPRIETARY TO MOLEX INCORPORATED AND SHOULD NOT BE USED WITHOUT WRITTEN PERMISSION				