

PART NUMBER	REVISION	DESCRIPTION	FEED TYPE
2150422-1	B	FINE CRIMP HEIGHT ADJUST	MECHANICAL
2150422-2	B	FINE CRIMP HEIGHT ADJUST	PNEUMATIC
7-2150422-1	B	MECHANICAL AND CRIMP TOOLING KIT	MECHANICAL
7-2150422-2	B	PNEUMATIC AND CRIMP TOOLING KIT	PNEUMATIC
7-2150422-7	A	CRIMP TOOLING KIT	-

ATLANTIC VERSION TERMINATOR INTERFACE ADAPTER



APPLICATOR DATA		
CRIMP	SIZE	TYPE
WIRE	2.54 mm [.100]	F
INSUL	4.06 mm [.160]	F
APPLICATOR INSTRUCTIONS 408-35043		

TERMINAL DATA: G&H(LEAR) TERMINAL TE CRIMP SPECIFICATION			
TERMINAL NAME: SIKO 2-FSH. 6,3-0,8			
WIRE STRIP LENGTH		INSULATION DIAMETER RANGE	
4.70-5.30 mm [.185-.209 IN]		∅3.10-3.70 mm [.122-.146 IN]	
TERMINAL APPLICATION SPECIFICATION	NONE		
TERMINALS APPLIED			
TE TERMINAL	G&H(LEAR) TERMINAL	TE TERMINAL	G&H(LEAR) TERMINAL
2113439-1	26112.123.178	2113439-3	26112.201.178
2113439-2	26112.123.009	2113439-4	TERM403-CK9

WIRE SIZE	CRIMP HEIGHT mm [INCH]	CRIMP HEIGHT REFERENCE SETTING
2.50mm ²	2.02 +/- 0.05 [.080 +/- .002]	7.1
2.00mm ²	1.86 +/- 0.05 [.073 +/- .002]	8.9
1.50mm ²	1.70 +/- 0.05 [.067 +/- .002]	10.5

- 1. RECOMMENDED SPARE PARTS
- 2. REFER TO SUPPLIED INSTRUCTION SHEET FOR CLEANING, LUBRICATION AND STORAGE OF APPLICATOR.
- 3. APPLY PART NUMBER 2-23419-6 LOCTITE TO THREADS OF ITEM 242. APPLY PART NUMBER 1-23419-5 LOCTITE TO THREADS OF ITEM 180.
- 4. CRIMP HEIGHT REFERENCE SETTING WAS THE SETTING USED WHEN THE APPLICATOR WAS QUALIFIED AT THE FACTORY. ADJUSTMENT MAY BE NECESSARY WHEN RUNNING APPLICATOR IN THE FIELD.
- 5. UNLESS SPECIFIED OTHERWISE TORQUE VALUES SHALL BE USED PER DOCUMENT, 101-35000.

***WARNING**
ON INSTALLATION, SET WIRE DISC TO CRIMP HEIGHT REFERENCE SETTING FOR LARGEST WIRE SIZE. CRIMP HEIGHT REFERENCE SETTINGS GREATER THAN THE VALUE SHOWN MAY CAUSE DAMAGE TO THE CRIMP TOOLING. REFER TO THE INSTRUCTION SHEET FOR PROPER SETUP AND ADJUSTMENTS.

ATLANTIC VERSION
Shown on sheets 1 of 4 & 2 of 4
(Pacific version shown on sheets 3 of 4 & 4 of 4)

LOC	DIST	REVISIONS					
		P	LTN	DESCRIPTION	DATE	OWN	APVD
A	66	A		RELEASED	27MAR2014	LG	TE
		B		ECR-22-129533	14FEB2022	TB	RK

-	1	-	1	-	2119641-1	FEED CAM, AIR FEED	248
-	1	1	1	1	2119082-9	CAM, SNAIL, INSULATION ADJUSTMENT	244
-	1	1	1	1	2079764-1	WASHER, WAVE SPRING, CREST-TO-CREST	243
-	1	1	1	1	2119083-1	RETAINER, INSULATION DIAL	242
-	-	1	-	1	2119580-1	MECHANICAL FEED ASSEMBLY	239
-	1	-	1	-	2844940-3	AIR FEED MODULE	238
-	1	1	1	1	1-18028-0	WASHER, FLAT, REG M8	192
-	1	1	1	1	1-1752354-3	STANDOFF, HOLD-DOWN	180
-	1	1	1	1	6-993111-6	PIN, SLOTTED SPRING 3.0 X 14.0	177
-	1	1	1	1	8-22280-7	SPRING, COMPRESSION	176
-	1	1	1	1	1752353-2	GUIDE PIN, HOLDDOWN	175
-	1	1	1	1	1901680-2	GUIDE PIN, HOLDDOWN	174
-	REF	REF	REF	REF	994970-2	COUNTER, MAGNETIC	164
-	1	1	1	1	455888-4	SPACER, CRIMPER	82
-	1	1	1	1	2119791-5	DEPRESSOR, WIRE	73
-	1	1	1	1	1803607-4	DOCUMENTATION PACKAGE	71
-	2	2	2	2	2-18032-2	SCR, SET, FLT PNT, M3 X 10.0	70
-	1	1	1	1	2119740-1	TAG, IDENTIFICATION	67
-	2	2	2	2	2168078-1	SCREW, DRIVE, RH, RoHS, 2 x .188	66
-	1	1	1	1	1901681-1	HOLDDOWN, TERMINAL	65
-	1	1	1	1	2168083-2	SCR, SKT HD CAP, RoHS, M4 X 8.0	60
-	1	1	1	1	5-18022-5	SCR, HEX HD CAP, M4 X 6.0	59
-	-	1	-	1	2063961-1	FEED FINGER	58
-	4	4	4	4	2168400-4	SHCS, LOW HEAD, RoHS, M4 X 8	57
-	2	2	2	2	2168083-3	SCR, SKT HD CAP, RoHS, M4 X 12.0	56
-	2	2	2	2	5018030-1	NUT, HEX, REG, RoHS, M3	54
-	2	2	2	2	986965-8	NUT, LOCK, HEX, TORQUE (M4)	53
-	1	1	1	1	1-5018030-0	NUT, HEX, REG, RoHS, M3.5	52
-	1	-	1	-	2063961-1	FEED FINGER	51
-	1	2	1	2	18023-9	SCR, SKT HD CAP M4 X 6.0	49
-	-	1	-	1	2119652-1	FEED CAM, PRE FEED	48
-	-	1	-	1	2119653-1	FEED CAM, POST FEED	47
-	1	1	1	1	2119655-5	APPLICATOR BASIC ASSEMBLY, EF	46
-	1	1	1	1	1803517-1	RAM ASSEMBLY, EF ATLANTIC	44
-	1	1	1	1	1803602-1	SCR, BHSC, RoHS (M8 X 25)	41
-	8	8	8	8	1-18028-2	WASHER, FLAT, REG M4	33
-	2	2	2	2	2168083-9	SCR, SKT HD CAP, RoHS, M4 X 20	31
-	2	2	2	2	2168083-2	SCR, SKT HD CAP, RoHS, M4 X 8.0	29
-	1	1	1	1	240639-1	STRIPPER (MACHINING)	27
-	2	2	2	2	1-2168083-5	SCR, SKT HD CAP, RoHS, M4 X 30	25
-	1	1	1	1	1752371-5	PLATE, STRIP GUIDE	24
-	2	2	2	2	2-22281-3	SPRING, COMPRESSION	22
-	1	1	1	1	1803292-4	DRAG	20
-	2	2	2	2	1901259-6	GUIDE, LOWER STRIP	18
-	4	4	4	4	1-2079383-1	SCR, BHSC, RoHS (M6 X 12)	17
-	1	1	1	1	1752360-1	SPACER, HOLD-DOWN	13
-	1	1	1	1	240644-1	PLATE, REAR SHEAR	11
-	-	-	-	-	-	-	10
-	1	1	1	1	1-690482-2	PLATE, FRONT SHEAR	9
-	1	2	2	1	1803060-6	ANVIL, COMBINATION, END FEED	8
-	1	1	1	1	2217206-7	BLADE, SLUG	7
-	-	-	-	-	-	-	6
-	1	1	1	1	7-240641-5	SPACER	5
-	1	1	1	1	238011-4	BLOCK, CRIMPER SPACER	4
-	1	2	2	1	1-1633961-4	CRIMPER, INSULATION F PREMIUM	3
-	1	1	1	1	455888-3	SPACER, CRIMPER	2
-	1	2	2	1	3-456407-5	CRIMPER, WIRE PREMIUM	1
-	77-72-71	-	2	-	1	PART NO	ITEM NO

DIMENSIONS:		TOLERANCES UNLESS OTHERWISE SPECIFIED:		OWN	26FEB2014	STE		TE Connectivity
mm	0 PLC ±	1 PLC ±	2 PLC ±	H. HUANG	26FEB2014	Harrisburg, PA 17105-3608		
	3 PLC ±	4 PLC ±	ANGLES ±	L. ZHANG	26FEB2014	NAME		
MATERIAL:	FINISH:	WEIGHT:	SCALE:	U. GUO	26FEB2014	PRODUCT SPEC		
						APPLICATION SPEC		
						SIZE		
						CAGE CODE		
						DRAWING NO		
						RESTRICTED TO		
						A1 00779		
						C=2150422		
						Customer Accessible Production Drawing		
						SCALE		
						1:1		
						SHEET		
						1 of 4		
						REV		
						B		

THIS DRAWING IS UNPUBLISHED. RELEASED FOR PUBLICATION 20
 COPYRIGHT 20 BY TYCO ELECTRONICS CORPORATION. ALL RIGHTS RESERVED.

PART NUMBER	REVISION	DESCRIPTION	FEED TYPE
2-2150422-1	B	FINE CRIMP HEIGHT ADJUST	MECHANICAL
2-2150422-2	B	FINE CRIMP HEIGHT ADJUST	PNEUMATIC
7-2150422-7	A	CRIMP TOOLING KIT	-

PACIFIC VERSION TERMINATOR
 INTERFACE ADAPTER

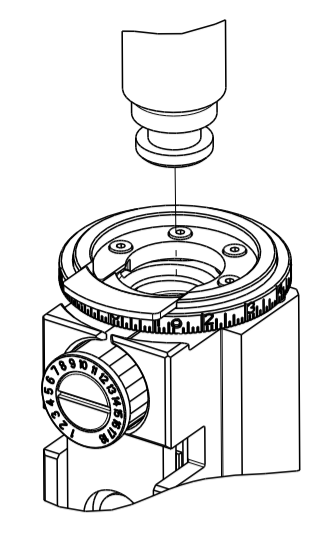

APPLICATOR DATA		
CRIMP	SIZE	TYPE
WIRE	2.54 mm [.100]	F
INSUL	4.06 mm [.160]	F
APPLICATOR INSTRUCTIONS 408-35043		

TERMINAL DATA: G&H(LEAR) TERMINAL TE CRIMP SPECIFICATION			
TERMINAL NAME: SIKO 2-FSH. 6,3-0,8			
WIRE STRIP LENGTH 4.70-5.30 mm [.185-.209 IN]		INSULATION DIAMETER RANGE Ø3.10-3.70 mm [.122-.146 IN]	
TERMINAL APPLICATION SPECIFICATION	NONE	-	-
TERMINALS APPLIED			
TE TERMINAL	G&H(LEAR) TERMINAL	TE TERMINAL	G&H(LEAR) TERMINAL
2113439-1	26112.123.178	2113439-3	26112.201.178
2113439-2	26112.123.009	2113439-4	TERM403-CK9

WIRE SIZE	CRIMP HEIGHT mm [INCH]	CRIMP HEIGHT REFERENCE SETTING
2.50mm2	2.02 +/- 0.05 [.080 +/- .002]	7.1
2.00mm2	1.86 +/- 0.05 [.073 +/- .002]	8.9
1.50mm2	1.70 +/- 0.05 [.067 +/- .002]	10.5

- RECOMMENDED SPARE PARTS
- REFER TO SUPPLIED INSTRUCTION SHEET FOR CLEANING, LUBRICATION AND STORAGE OF APPLICATOR.
- APPLY PART NUMBER 2-23419-6 LOCTITE TO THREADS OF ITEM 242. APPLY PART NUMBER 1-23419-5 LOCTITE TO THREADS OF ITEM 180.
- CRIMP HEIGHT REFERENCE SETTING WAS THE SETTING USED WHEN THE APPLICATOR WAS QUALIFIED AT THE FACTORY. ADJUSTMENT MAY BE NECESSARY WHEN RUNNING APPLICATOR IN THE FIELD.
- UNLESS SPECIFIED OTHERWISE TORQUE VALUES SHALL BE USED PER DOCUMENT, 101-35000.

***WARNING**
 ON INSTALLATION, SET WIRE DISC TO CRIMP HEIGHT REFERENCE SETTING FOR LARGEST WIRE SIZE. CRIMP HEIGHT REFERENCE SETTINGS GREATER THAN THE VALUE SHOWN MAY CAUSE DAMAGE TO THE CRIMP TOOLING. REFER TO THE INSTRUCTION SHEET FOR PROPER SETUP AND ADJUSTMENTS.

LOC	DIST	REVISIONS					
		P	LTN	DESCRIPTION	DATE	OWN	APVD
A	66	-	-	SEE SHEET 1	-	-	-

-	1	1	2119082-9	CAM, SNAIL, INSULATION ADJUSTMENT	244	
-	1	1	2079764-1	WASHER, WAVE SPRING, CREST-TO-CREST	243	
-	1	1	2119083-1	RETAINER, INSULATION DIAL	242	
-	-	1	2119580-1	MECHANICAL FEED ASSEMBLY	239	
-	1	-	2844940-3	AIR FEED MODULE	238	
-	1	1	1-18028-0	WASHER, FLAT, REG M8	192	
-	4	4	2079383-9	SCR, BHSC, RoHS (M6 X 20)	186	
-	1	1	1-1752354-3	STANDOFF, HOLD-DOWN	180	
-	1	1	6-993111-6	PIN, SLOTTED SPRING 3.0 X 14.0	177	
-	1	1	8-22280-7	SPRING, COMPRESSION	176	
-	1	1	1752353-2	GUIDE PIN, HOLDDOWN	175	
-	1	1	1901680-2	GUIDE PIN, HOLDDOWN	174	
-	REF	REF	994970-2	COUNTER, MAGNETIC	164	
-	1	-	2119641-2	FEED CAM, AIR FEED	152	
-	1	1	2168083-8	SCR, SKT HD CAP, RoHS, M4 X 16	144	
-	-	1	2119653-2	FEED CAM, POST FEED	142	
-	1	1	2119655-6	APPLICATOR BASIC ASSEMBLY, EF	141	
-	1	1	1803518-1	RAM ASSEMBLY, EF PACIFIC	140	
-	1	1	455888-4	SPACER, CRIMPER	82	
-	1	1	2119791-5	DEPRESSOR, WIRE	73	
-	1	1	1803607-4	DOCUMENTATION PACKAGE	71	
-	2	2	2-18032-2	SCR, SET, FLT PNT, M3 X 10.0	70	
-	1	1	2119740-1	TAG, IDENTIFICATION	67	
-	2	2	2168078-1	SCREW, DRIVE, RH, RoHS, 2 x .188	66	
-	1	1	1901681-1	HOLDDOWN, TERMINAL	65	
-	1	1	5-18022-5	SCR, HEX HD CAP, M4 X 6.0	59	
-	-	1	2063961-1	FEED FINGER	58	
-	4	4	2168400-4	SHCS, LOW HEAD, RoHS, M4 X 8	57	
-	2	2	2168083-3	SCR, SKT HD CAP, RoHS, M4 X 12.0	56	
-	2	2	5018030-1	NUT, HEX, REG, RoHS, M3	54	
-	2	2	986965-8	NUT, LOCK, HEX, TORQUE (M4)	53	
-	1	1	1-5018030-0	NUT, HEX, REG, RoHS, M3.5	52	
-	1	-	2063961-1	FEED FINGER	51	
-	1	2	18023-9	SCR, SKT HD CAP M4 X 6.0	49	
-	-	1	2119652-1	FEED CAM, PRE FEED	48	
-	1	1	1803602-1	SCR, BHSC, RoHS (M8 X 25)	41	
-	8	8	1-18028-2	WASHER, FLAT, REG M4	33	
-	2	2	2168083-9	SCR, SKT HD CAP, RoHS, M4 X 20	31	
-	2	2	2168083-2	SCR, SKT HD CAP, RoHS, M4 X 8.0	29	
-	1	1	240639-1	STRIPPER (MACHINING)	27	
-	2	2	1-2168083-5	SCR, SKT HD CAP, RoHS, M4 X 30	25	
-	1	1	1752371-5	PLATE, STRIP GUIDE	24	
-	2	2	2-22281-3	SPRING, COMPRESSION	22	
-	1	1	1803292-4	DRAG	20	
-	2	2	1901259-6	GUIDE, LOWER STRIP	18	
-	1	1	1752360-1	SPACER, HOLD-DOWN	13	
-	1	1	240644-1	PLATE, REAR SHEAR	11	
-	-	-	-	-	10	
-	1	1	1-690482-2	PLATE, FRONT SHEAR	9	
-	1	1	1803060-6	ANVIL, COMBINATION, END FEED	8	
-	1	1	2217206-7	BLADE, SLUG	7	
-	-	-	-	-	6	
-	1	1	7-240641-5	SPACER	5	
-	1	1	238011-4	BLOCK, CRIMPER SPACER	4	
-	1	1	1-1633961-4	CRIMPER, INSULATION F PREMIUM	3	
-	1	1	455888-3	SPACER, CRIMPER	2	
-	1	1	3-456407-5	CRIMPER, WIRE PREMIUM	1	
-	77	22	21	PART NO	DESCRIPTION	ITEM NO

PACIFIC VERSION
 Shown on sheets 3 of 4 & 4 of 4
 (Atlantic version shown on sheets 1 of 4 & 2 of 4)

DIMENSIONS: mm		TOLERANCES UNLESS OTHERWISE SPECIFIED:		DWN: H. HUANG 26FEB2014		CHK: L. ZHANG 26FEB2014		APVD: J. GUO 26FEB2014		NAME: Ocean End Feed Applicator	
0 PLC ±		1 PLC ±		2 PLC ±		3 PLC ±		4 PLC ±		SIZE: A1	
ANGLES		FINISH		WEIGHT		SCALE: 1:1		SHEET: 3 OF 4		REV: B	
MATERIAL		FINISH		WEIGHT		SCALE: 1:1		SHEET: 3 OF 4		REV: B	

Customer Accessible Production Drawing

LOC		DIST		REVISIONS			
A	66	P	LTM	DESCRIPTION	DATE	OWN	APVD
		-		SEE SHEET 1			

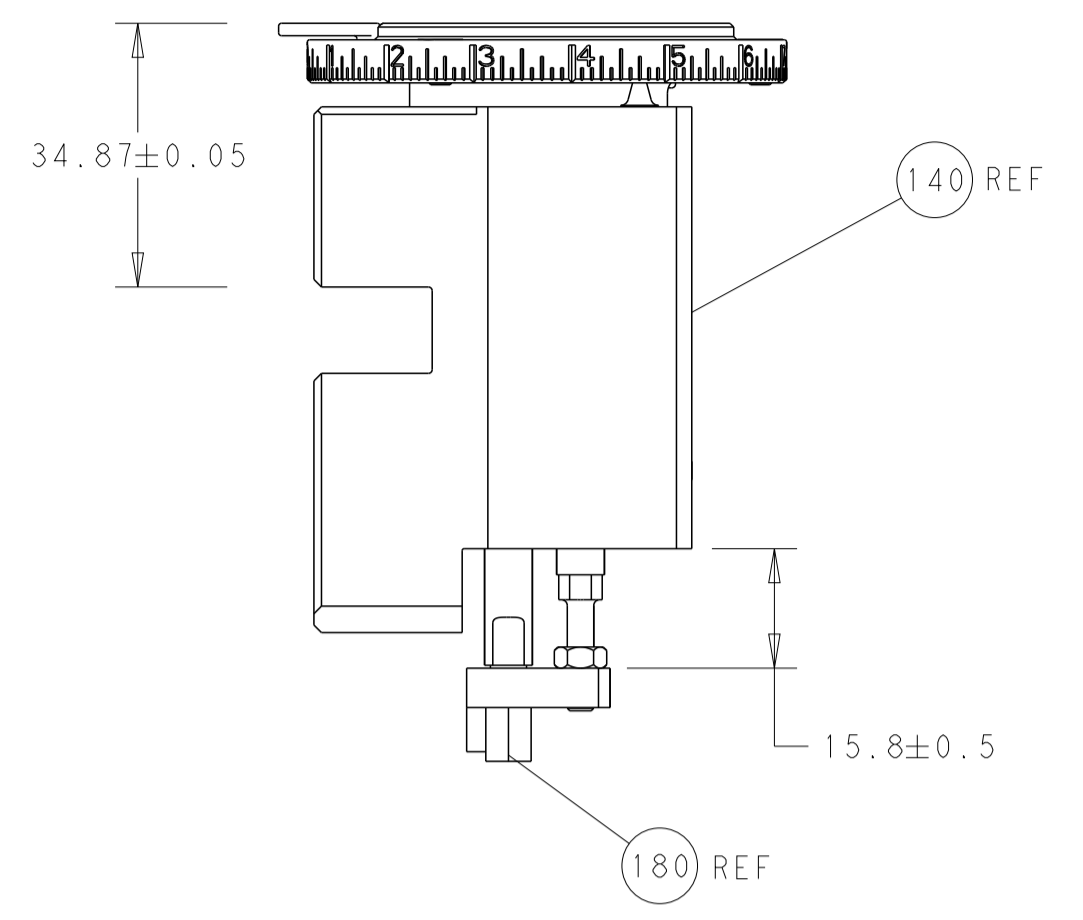

RAM AND HOLDDOWN SET-UP

FEED TYPE
MECHANICAL

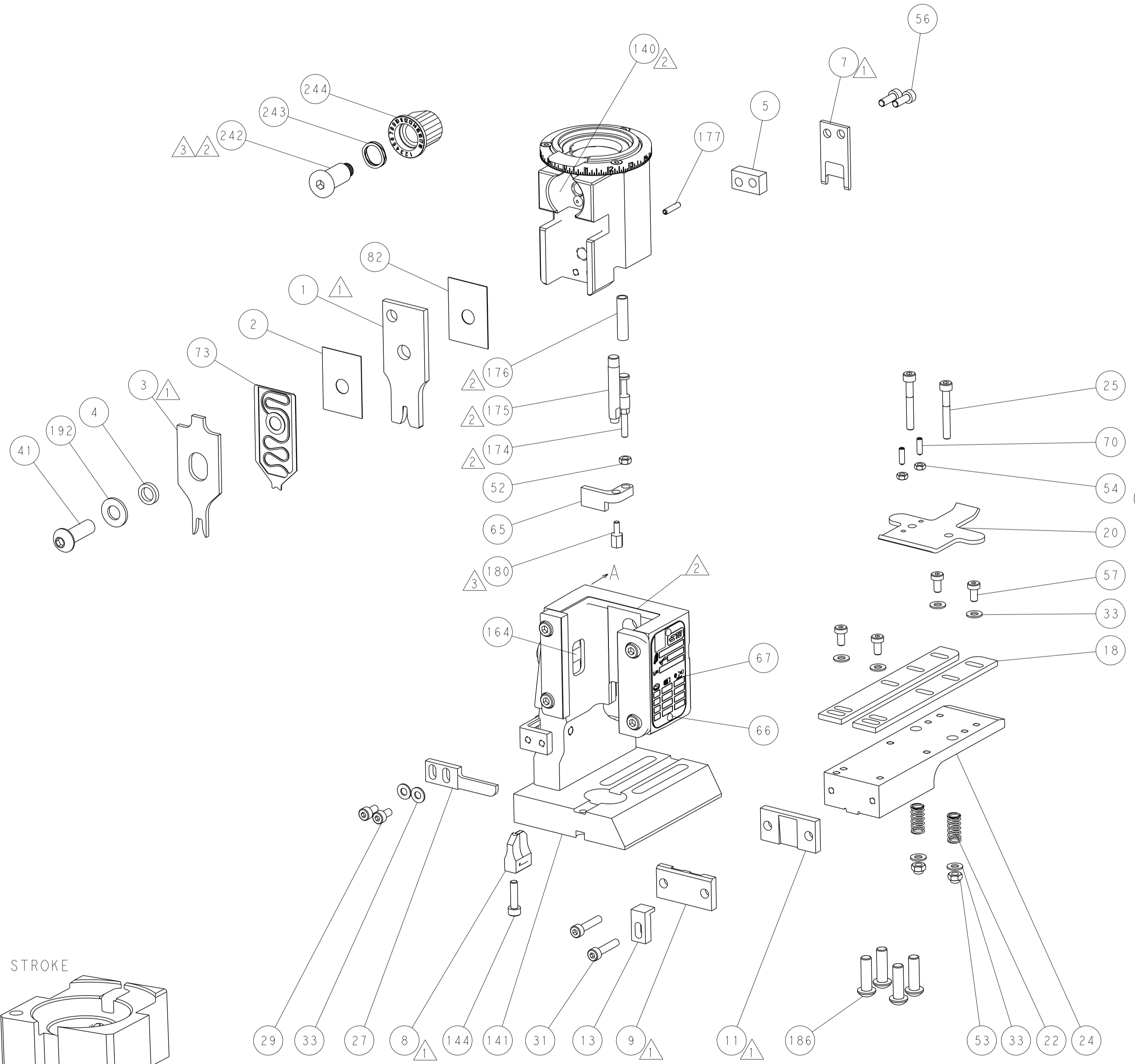
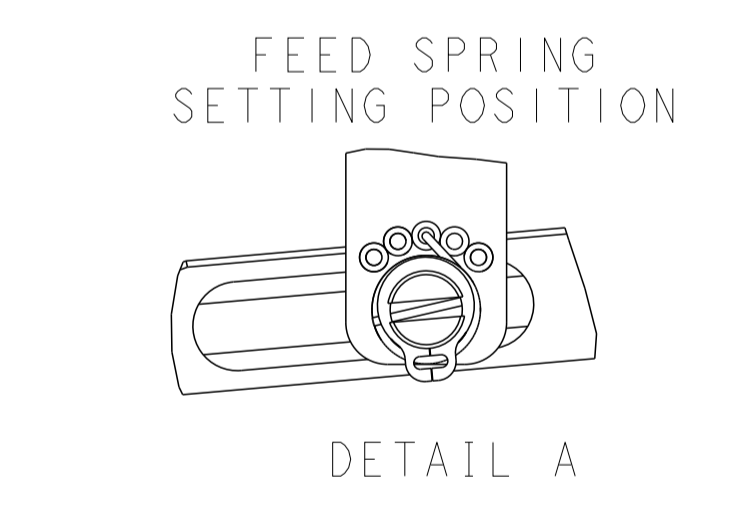
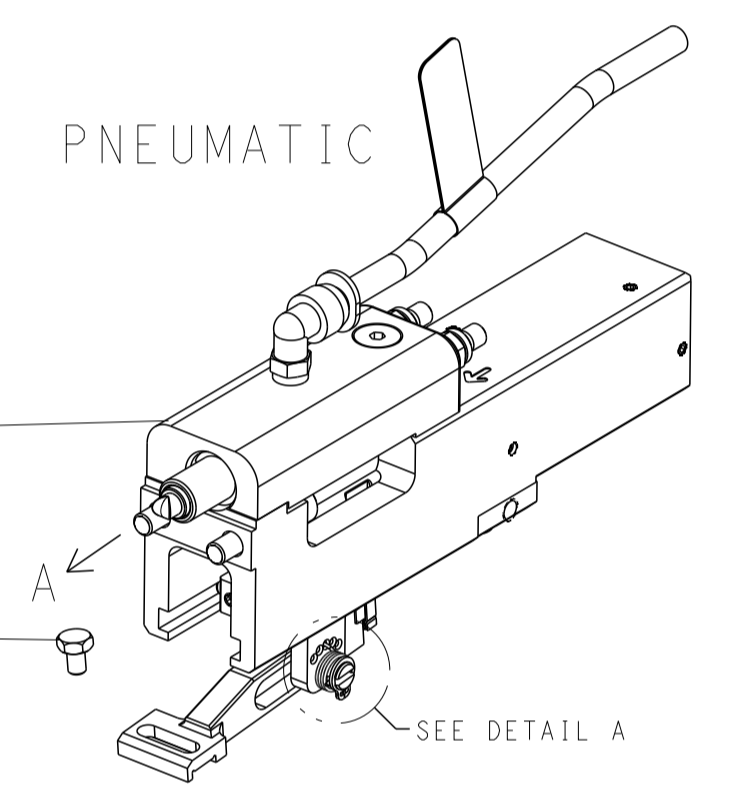
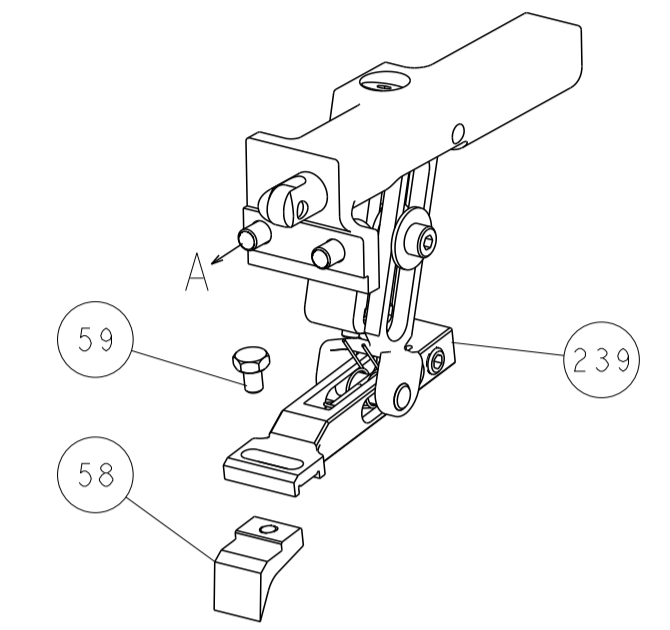

CAM POSITIONS

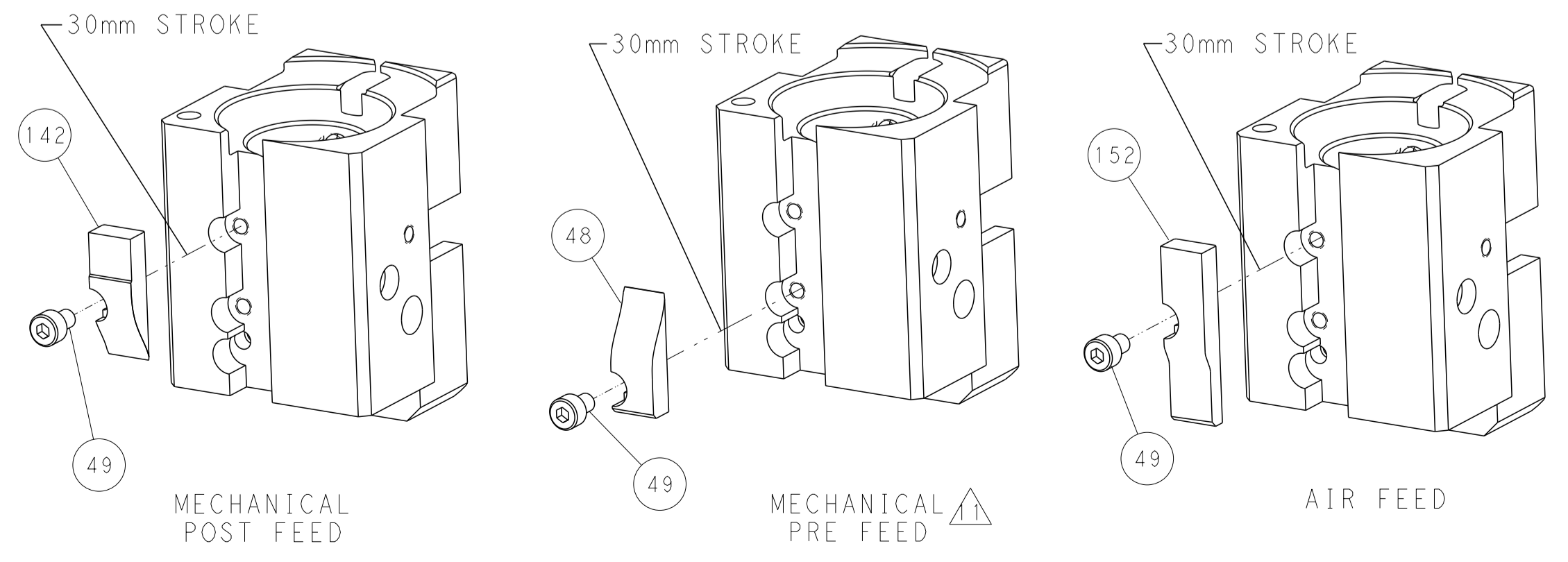

PACIFIC VERSION
 Shown on sheets 3 of 4 & 4 of 4
 (Atlantic version shown on sheets 1 of 4 & 2 of 4)

DIMENSIONS:		TOLERANCES UNLESS OTHERWISE SPECIFIED:		OWN: K. HUANG 26FEB2014		CHK: L. ZHANG 26FEB2014		APVD: J. GUO 26FEB2014		NAME: Ocean End Feed Applicator	
mm	0 PLC	±		SIZE	CAGE CODE	DRAWING NO	RESTRICTED TO	STE TE Connectivity Harrisburg, PA 17105-3608			
	1 PLC	±		SCALE	1:1	SHEET 4 OF 4	REV B	Customer Accessible Production Drawing			
	2 PLC	±		A 00779 ©=2150422							
	3 PLC	±		SHEETS 1 & 2 ARE NOT REQUIRED FOR PACIFIC VERSION							
	4 PLC	±									
	ANGLES	±									
	FINISH	±									