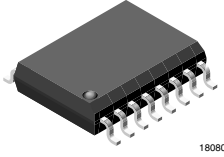


SIR Endec for IrDA® Applications Integrated Interface Circuit



DESCRIPTION

The TOIM4232 Endec IC provides proper pulse shaping for the SIR IrDA® front end infrared transceivers as of the 4000-series. For transmitting the TOIM4232 shortens the RS232 output signal to IrDA compatible electrical pulses to drive the infrared transmitter. In the receive mode, the TOIM4232 stretches the received infrared pulses to the proper bit width depending on the operating bit rate. The IrDA bit rate varies from 2.4 kbit/s to 115.2 kbit/s. The TOIM4232 is using a crystal clock 3.6864 MHz for its pulse stretching and shortening. The clock can be generated by the internal oscillator. An external clock can be used, too. The TOIM4232 is programmable to operate from 1200 bit/s to 115.2 kbit/s by the communication software through the RS232 port. The output pulses are software programmable as either 1.627 μ s or 3/16 of bit time. The typical power consumption is very low with about 10 mW in operational state and in the order of a few microwatts in standby mode.

ULC TECHNOLOGY

High performance gate array package using multiple metal layer CMOS technology featuring sub-micron channel lengths (0.35 μ m).

FEATURES

- Pulse shaping function (shortening and stretching) used in SIR IrDA applications
- Directly interfaces the SIR transceiver TFD... and TFB... series to an RS232 port
- Programmable baud clock generator (1200 Hz to 115.2 kHz), 13 baud rates
- 3/16 bit pulse duration or 1.627 μ s pulse selectable
- SO16 - package
- 2.7 V to 3.6 V operation voltage, 5 V tolerant inputs
- Low operating current
- Qualified for lead (Pb)-free and Sn/Pb processing (MSL3)
- Compliant to RoHS Directive 2002/95/EC and in accordance to WEEE 2002/96/EC

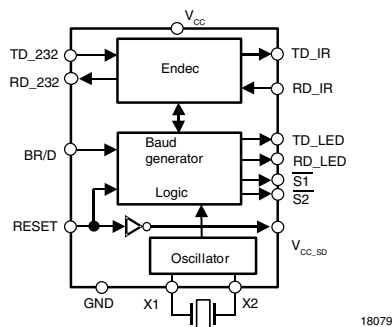

RoHS
COMPLIANT

PARTS TABLE

PART	DESCRIPTION	QTY/REEL
TOIM4232-TR3	-	1500 pcs

PRODUCT SUMMARY

PART NUMBER	DATA RATE (kbit/s)	DIMENSIONS H x L x W (mm x mm x mm)	LINK DISTANCE (m)	OPERATING VOLTAGE (V)	IDLE SUPPLY CURRENT (mA)
TOIM4232	115.2	4 x 4 x 0.75	-	2.7 to 3.6	2

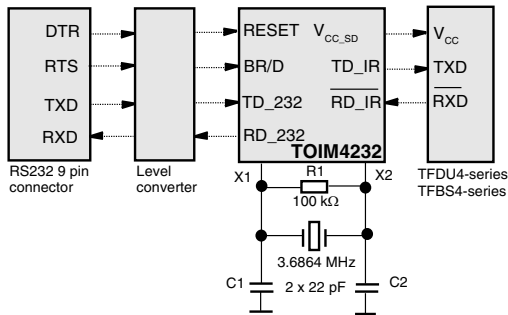
BLOCK DIAGRAM


PIN DESCRIPTION				
PIN NUMBER	SYMBOL	DESCRIPTION	I/O	ACTIVE
1	RESET	Resets all internal registers. Initially must be high ("1") to reset internal registers. When high, the TOIM4232 sets the IrDA default bit rate of 9600 bit/s, sets pulse width to 1.627 μ s. The V_{CC_SD} output is simply an inverted reset signal which allows to shut down of a TFDx4x00 transceiver when applying the reset signal to the TOIM4232. When using devices with external SD like TFDU4203, the reset line can be used directly as shut down signal. RESET pin can be controlled by either the RTS or DTR line through RS232 level converter. Minimum hold time for resetting is 1 μ s. Disables the oscillator when active.		High
2	BR/D	<p>Baud rate control/ data.</p> <p>BR/D = 0, data communication mode: RS232 TXD data line is connected (via a level shifter) to TD_232 input pin. The TXD - signal is appropriately shortened and applied to the output TD_IR, driving the TXD input of the IR transceiver. The RXD line of the transceiver is connected to the RD_IR input. This signal is stretched to the correct bit length according to the programmed bit rate and is routed to the RS232 RXD line at the RD_232 pin.</p> <p>BR/D = 1, programming mode: Data received from the RS232 port is interpreted as control word. The control word programs the baud rate width will be effective as soon as BR/D return to low.</p>		
3	RD_232	Received signal data output of stretched signal to the RS232 RXD line (using level converter).	O	High
4	TD_232	Input of the signal to be transmitted from the RS232 port TXD line (passing the level converter).	I	High
5	V_{CC_SD}	Outputs an inverted RESET signal. Can be used to shut down the power supply of a 4000 series transceiver (e.g., TFDU4100). V_{CC} shutdown output function. This pin can be used to shut down a transceiver (e.g., TFDx4xxx). Output polarity: Inverted RESET input.	O	Low
6	X1	Crystal input clock, 3.6864 MHz nominal. Input for external clock ⁽¹⁾	I	
7	X2	Crystal ⁽¹⁾	I	
8	GND	Ground in common with the RS232 port and IrDA transceiver ground		
9	TD_LED	Transmit LED indicator driver. Use 180 Ω current limiting resistor in series to LED to connect to V_{CC} . ($V_{CC} = 3.3$ V)	O	Low
10	RD_LED	Receive LED indicator driver. Use 180 Ω current limiting resistor in series to LED to connect to V_{CC} . ($V_{CC} = 3.3$ V)	O	Low
11	NC	No connection		
12	S1	User programmable bit. Can be used to turn on/off a front-end infrared transceiver (e.g., an infrared module at the adapter front)	O	Low
13	S2	User programmable bit. Can be used to turn on/off a front-end infrared transceiver (e.g., an infrared module at the adapter back)	O	Low
14	TD_IR	Data output of shortened signal to the infrared transceiver	O	High
15	RD_IR	Data input from the infrared transceiver, min. pulse duration 1.63 μ s ⁽²⁾	I	Low
16	VCC	Supply voltage	I	

Notes

⁽¹⁾ Crystal should be connected as shown in figure 2. In addition connect a 100 k Ω resistor from pin 6 to pin 7 and from pin 6 and pin 7 a 22 pF capacitor to ground, respectively. When an external clock is available connect it to pin 6 leaving pin 7 open. The external resistor of 100 k Ω is used to accelerate the start of oscillation after reset or power - on. The value depends on the "Q" of the resonator. With low Q resonators it is not necessary. The start - up time of the oscillator is between 30 μ s (with piezo resonators) and above 2 ms with high Q quartzes.

⁽²⁾ All Vishay Semiconductor SIR transceivers fulfill this condition.

BLOCK DIAGRAM OF APPLICATION CIRCUIT


Operating the interface circuit at a PC COM - port. When operating directly with an UART with 3 V - or 5 V - logic, in the application circuit no level converter is necessary.

18081

RECOMMENDED APPLICATION CIRCUIT COMPONENTS

COMPONENT	RECOMMENDED VALUE	VISHAY PART NUMBER
C1	22 pF	VJ 1206 A 220 J XAMT
C2	22 pF	VJ 1206 A 220 J XAMT
R1	100 kΩ	CRCW-1206-1003-F-RT1
Quartz crystal	3.686400 MHz	XT49S - 20 - 3.686400M

ABSOLUTE MAXIMUM RATINGS

PARAMETER	TEST CONDITIONS	SYMBOL	MIN.	TYP.	MAX.	UNIT
Supply voltage		V_{CC}	- 0.5		3.6	V
Input voltage	All pins		- 0.5		5.5	V
Output voltage	All pins		- 0.5		$V_{CC} + 0.5$	V
Output sinking current, max.	All pins	I_O			8	mA
Junction temperature, max.		T_J			125	°C
Ambient temperature (operating)		T_{amb}	- 25		85	°C
Storage temperature		T_{stg}	- 25		85	°C
Soldering temperature		T_{sldr}			260	°C

DC CHARACTERISTICS

PARAMETER	TEST CONDITIONS	SYMBOL	MIN.	TYP.	MAX.	UNIT
Operating voltage		V_{CC}	2.7	3.3	3.6	V
$V_{CC} = 3.3 \text{ V} \pm 5 \%$, operating temperature = - 25 °C to + 85 °C						
Input high voltage	Inputs tolerate levels as high as 5.5 V max. All inputs are Schmitt trigger inputs	V_{IH}	2			V
Input low voltage		V_{IL}			0.8	V
Input Schmitt trigger hysteresis		V_{hyst}		0.6		V
Input leakage no pull-up/down	$V_{IN} = V_{DD}$ or GND	I_L	- 10	± 1	10	μA
Output high voltage	$I_{OH} = - 2 \text{ mA}$	V_{OH}	2			V
	$I_{OH} = - 0.5 \text{ mA}$	V_{OH}	2.4			V
Output low voltage	$I_{OL} = + 2 \text{ mA}$	V_{OL}			0.4	V
Consumption current standby	Inputs grounded, no output load $V_{CC} = 3.3 \text{ V}$, $T = 25 \text{ °C}$	I_{SB}			1	μA
Consumption current dynamic	Inputs grounded, no output load $V_{CC} = 3.3 \text{ V}$, $T = 25 \text{ °C}$	I_{CC}		2		mA

OPERATION DESCRIPTION

The block diagram shows a typical example of an RS232 port interface. The TOIM4232 connects to an RS232 level converter on one side, and an infrared transceiver on the other. The internal TOIM4232 baud rate generator can be software controlled.

When BR/D = 0, the TOIM4232 interprets the channels TD_232 to TD_IR and RD_IR to RD_232 as data channels.

On the other hand, whenever BR/D = 1, the TOIM4232 interprets TD_232 as control word for setting the Baud rate. The Baud rate can be programmed to operate from 1200 bit/s to 115.2 kbit/s. As RS232 level converter, EIA232 or MAX232 or equivalent are recommended.

When using the TOIM4232 directly connected to an UART it is compatible to 5 V TTL and 3.3 V CMOS logic.

Typical external resistors and capacitors are needed as shown in the TFDU4.../TFBS4...-series references.

The output pulse duration can also be programmed, see chapter "Operation Description". It is strongly recommended using 1.627 µs output pulses to save battery power. As frequency determining component a Vishay XT49M crystal is recommended, when no external clock is available.

We strongly recommend not to use this 3/16 mode because 3/16 pulse length at lower bit rates consumes more power than the shorter pulse. At a data rate of 9600 bit/s, the ratio of power consumption of both modes is a factor of 12 (!).

PROGRAMMING THE TOIM4232

For correct, data rate dependent timing the TOIM4232 is using a built-in baud rate generator. This is used when no external clock is not available as in RS232 IR-dongle applications. For programming the BR/D pin has to be set active, BR/D = 1.

In this case the TOIM4232 interprets the 7 LSBs at the TD_232 input as a control word. The operating baud rate will change to its supposedly new baud rate when the BR/D returns back to low ("0") Set the UART to 8 bit, no parity, 1 stop bit.

CONTROL BYTE (8 BIT)							
FIRST CHARACTER				SECOND CHARACTER			
X	S2	S1	S0	B3	B2	B1	B0
							LSB

X: do not care

S1, S2: user programmable bit to program the outputs S1 and S2

S0: IrDA pulse select

S0 = (1): 1.627 µs pulses

S0 = (0): 3/16 bit time pulses, not recommended

B0 .. B3: baud rate select words

Example:

To set TOIM4232 at COM2 port (2F8) to 9600 bit/s with 3/16 bit time pulse duration send to the TOIM4232 in programming mode in e.g. "basic"

OUT &H2F8, (&H6)

For same port, 9600 bit/s and 1.627 µs pulse duration send

OUT &H2F8, (&H16)

For additionally activating S1 send

OUT &H2F8, (&H36)

TABLE 2 - BAUD RATE SELECT WORDS

B3	B2	B1	B0	2 ND CHAR	BAUD RATE
0	0	0	0	0	115.2 kHz
	0	0	1	1	57.6 kHz
	0	1	0	2	38.4 kHz
	0	1	1	3	19.2 kHz
	1	0	0	4	14.4 kHz
	1	0	1	5	12.8 kHz
	1	1	0	6	9.6 kHz
1	1	1	1	7	7.2 kHz
	0	0	0	8	4.8 kHz
	0	0	1	9	3.6 kHz
	0	1	0	A	2.4 kHz
	0	1	1	B	1.8 kHz
	1	0	0	C	1.2 kHz
	1	0	1	D	forbidden
	1	1	0	E	forbidden
1	1	1	F	forbidden	

Note

IrDA standard only supports 2.4 kbit/s, 9.6 kbit/s, 19.2 kbit/s, 57.6 kbit/s, and 115.2 kbit/s.

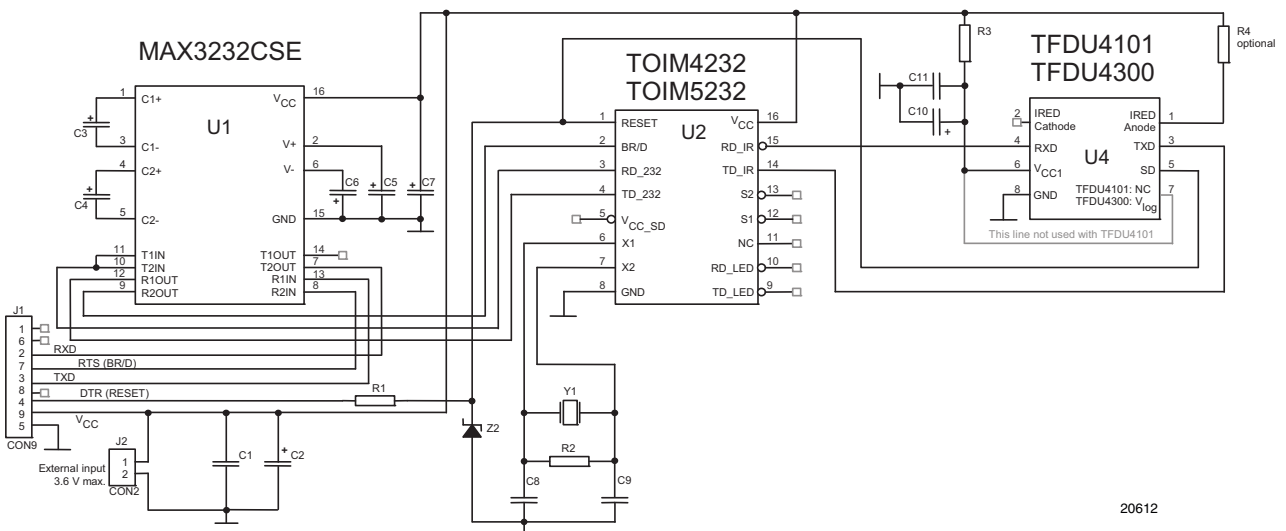
**SOFTWARE FOR THE TOIM4232
 UART PROGRAMMING**

For proper operation, the RS232 must be programmed (using 8 bit, 1 stop, no parity) to send a two character control word, YZ. The control word YZ is composed of two characters, written in hexadecimal, in format: YZ. The transfer rate for programming must be identical with the formerly programmed data rate, or after resetting the TOIM4232, the default rate of 9600 bit/s is used.

STEP.	RESET	BR/D	TD_UART	RD_UART	RD_IR	TD_IR	DESCRIPTION AND COMMENTS
1	High	X	X	X	X	X	Resets all internal registers. Resets to IrDA default data rate of 9600 bit/s
2	Low	X	X	X	X	X	Wait at least 2 ms, to allow start-up of internal clock. When external clock is used: wait at least 7 μ s.
3	Low	High	X	X	X	X	Wait at least 7 μ s. TOIM4232 now is set to the control word programming mode
4	Low	High	YZ with Y = 1 for 1.627 μ s Y = 0 3/16 bit length	X	X	X	Sending the control word YZ. Examples: send "1Z" if 1.627 μ s pulses are intended to be used. Otherwise send "0Z" for 3/16 bit period pulses. "Y6" keeps the 9.6 kbit/s data rate. Z = 0 sets to 115.2 kbit/s, see programming table. Wait at least 1 μ s for hold-time.
5	Low	Low	Data	Data	Data	Data	With BR/D = 0, TOIM4232 is in the data communication mode. Both RESET and BR/D must be kept low ("0") during data transmission. Reprogramming to a new data rate can be resumed by restarting from step 3. The UART itself also must set to the correct data rate ⁽¹⁾ .

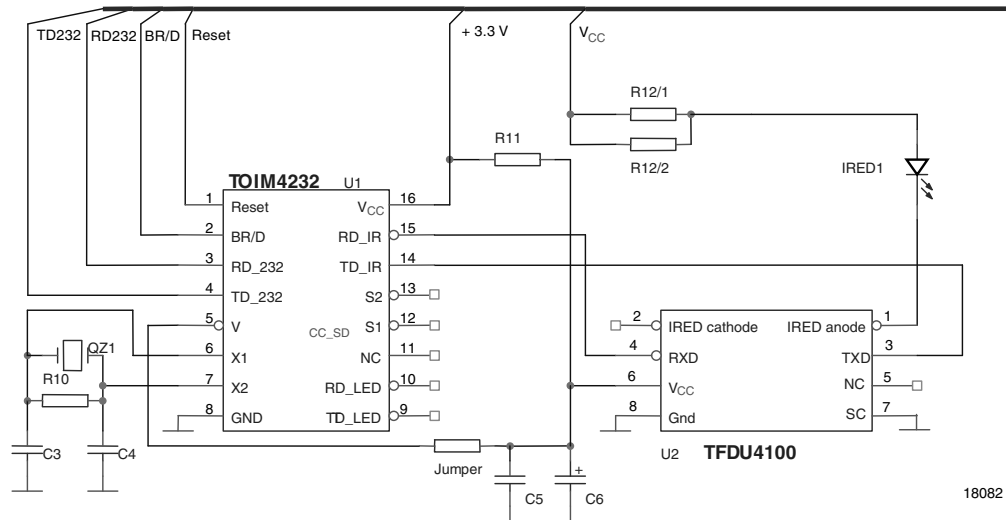
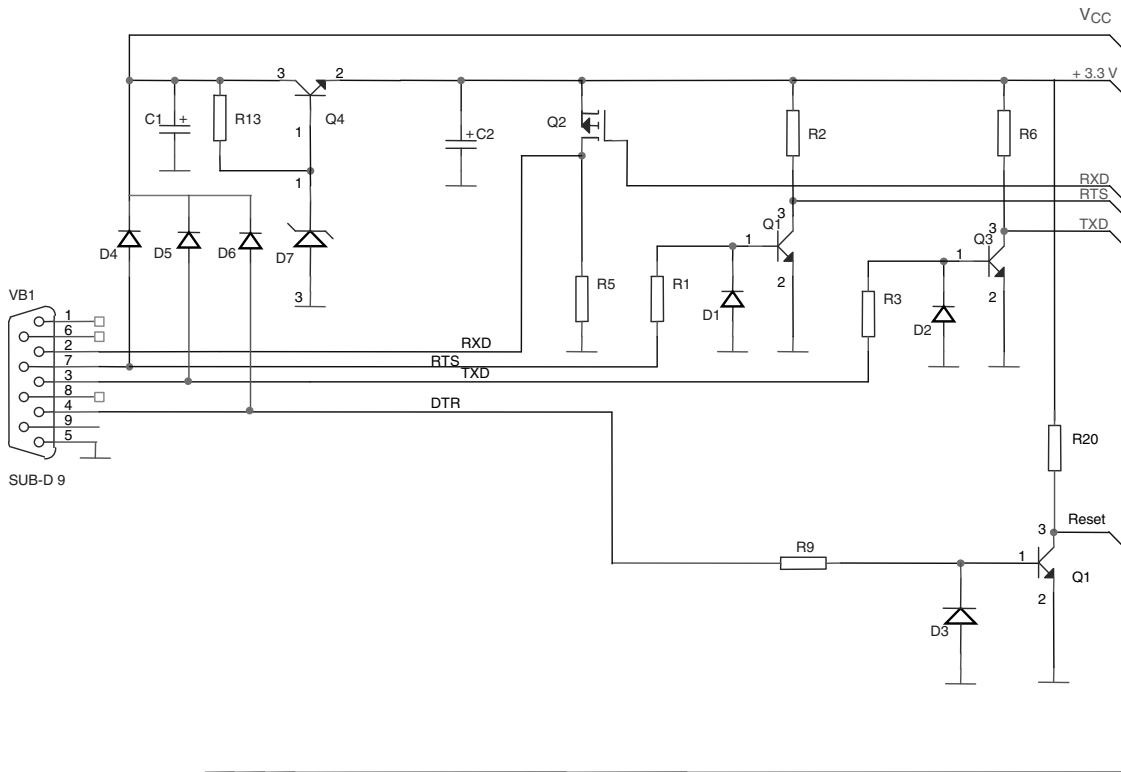
Note

⁽¹⁾ For programming the UART, refer to e.g., National Semiconductor's data sheet of PC 16550 UART

RECOMMENDED APPLICATION CIRCUIT WITH LEVEL SHIFTER


20612

RECOMMENDED APPLICATION CIRCUIT COMPONENTS			
	COMPONENT	RECOMMENDED VALUE	VISHAY PART NUMBER
1	C1	100 nF	VJ 1206 Y 104 J XXMT
2	C2	10 μ F, 16 V	293D106X9016B2T
3	C3	100 nF	VJ 1206 Y 104 J XXMT
4	C4	100 nF	VJ 1206 Y 104 J XXMT
5	C5	100 nF	VJ 1206 Y 104 J XXMT
6	C6	100 nF	VJ 1206 Y 104 J XXMT
7	C7	1 μ F, 16 V	293D105X9016A2T
8	C8	22 pF	VJ 1206 A 220 J XAMT
9	C9	22 pF	VJ 1206 A 220 J XAMT
10	C10	6.8 μ F, 16 V	293D 685X9 016B 2T
11	C11	100 nF	VJ 1206 Y 104 J XXMT
12	Z2	3.6 V	BZT55C3V6
13	R1	5.6 k Ω	CRCW-1206-5601-F-RT1
14	R2	Depending on resonator quality	CRCW-1206-1003-F-RT1
15	R3	47 Ω	CRCW-1206-47R0-F-RT1
16	R4	For operation according IrDA - spec not needed	Optional only for current reduction
17	Y1	3.686400 MHz	XT49S - 20 - 3.686400M or e.g. ceramic resonators
18	U1	MAXIM MAX 3232E	
19	U2		TOIM4232 or TOIM5232
20	U3		TFDU4300 or other compatible transceivers
21	J1	9 pin - D-sub	Cannon
22	J2	Power connector	

RECOMMENDED APPLICATION CIRCUIT WITH DISCRETE LEVEL SHIFTERS


Install jumper connection only when VCC_SD supplies U2. In that case leave R11 off.



RECOMMENDED APPLICATION CIRCUIT COMPONENTS			
	COMPONENT	RECOMMENDED VALUE	VISHAY PART NUMBER
1	C1	22 μ F, 16 V	293D 226X9 016C 2T
2	C2	47 μ F, 16 V	293D 476X9 016D 2T
3	C3	22 pF	VJ 1206 A 220 J XAMT
4	C4	22 pF	VJ 1206 A 220 J XAMT
5	C5	100 nF	VJ 1206 Y 104 J XXMT
6	C6	6.8 μ F, 16 V	293D 685X9 016B 2T
7	D1		1N4148
8	D2		1N4148
9	D4		BZT55C4V7
10	D5		1N4148
11	D6		1N4145
12	D7		BZT55C3V9
13	IREDD1		TSHF5400
14	Jumper		CRCW-1206-000-F-RT1
15	LED1		TLLY4401
16	LED2		TLLG4401
17	Q1		BC817-25
18	Q2		VP 0610 0T
19	Q3		BC817-25
20	Q4		BC817-25
21	QZ1	3.686400 MHz	XT49S - 20 - 3.686400M
22	R1	22 k Ω	CRCW-1206-2202-F-RT1
23	R2	10 k Ω	CRCW-1206-1002-F-RT1
24	R3	22 k Ω	CRCW-1206-2202-F-RT1
25	R5	1 k Ω	CRCW-1206-1001-F-RT1
26	R6	47 k Ω	CRCW-1206-4702-F-RT1
27	R9	5.6 k Ω	CRCW-1206-5601-F-RT1
28	R10	100 k Ω	CRCW-1206-1003-F-RT1
29	R11	100 Ω	CRCW-1206-1000-F-RT1
30	R12	20 Ω	CRCW-1206-20R0-F-RT1
21	R13	1 k Ω	CRCW-1206-1001-F-RT1
32	R17	750 Ω	CRCW-1206-7500-F-RT1
33	R18	750 Ω	CRCW-1206-750-F-RT1
34	VB1	9 pin - D - sub	Cannon
35	U1		TOIM4232 or TOIM5232
36	U2		TFDU4100 (will be obsolete). Replace by TFDU4101 and use external components as shown in the other example.

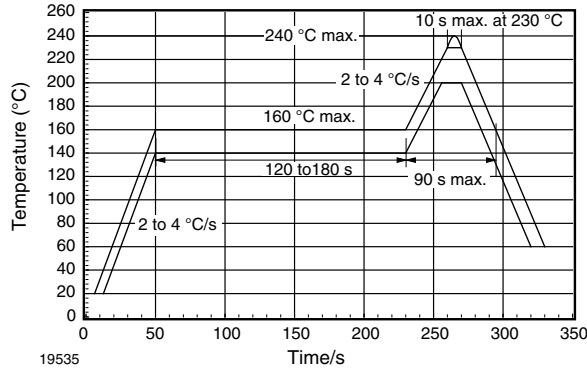
RECOMMENDED SOLDER PROFILES
Solder Profile for Sn/Pb Soldering


Fig. 1 - Recommended Solder Profile for Sn/Pb Soldering

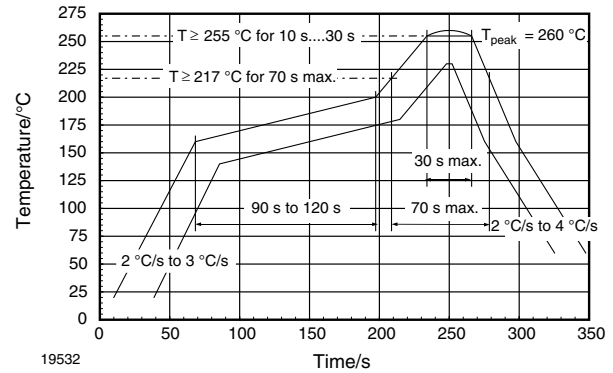


Fig. 2 - Solder Profile, RSS Recommendation

Lead (Pb)-free, Recommended Solder Profile

The TOIM4232 is a lead (Pb)-free transceiver and qualified for lead (Pb)-free processing. For lead (Pb)-free solder paste like $\text{Sn}_{(3.0 - 4.0)}\text{Ag}_{(0.5 - 0.9)}\text{Cu}$, there are two standard reflow profiles: Ramp-Soak-Spike (RSS) and Ramp-To-Spike (RTS). The Ramp-Soak-Spike profile was developed primarily for reflow ovens heated by infrared radiation. With widespread use of forced convection reflow ovens the Ramp-To-Spike profile is used increasingly. Shown below in figure 2 and 3 are Vishay's recommended profiles for use with the TOIM4232 transceivers. For more details please refer to the application note "SMD Assembly Instructions". A ramp-up rate less than 0.9 °C/s is not recommended. Ramp-up rates faster than 1.3 °C/s could damage an optical part because the thermal conductivity is less than compared to a standard IC.

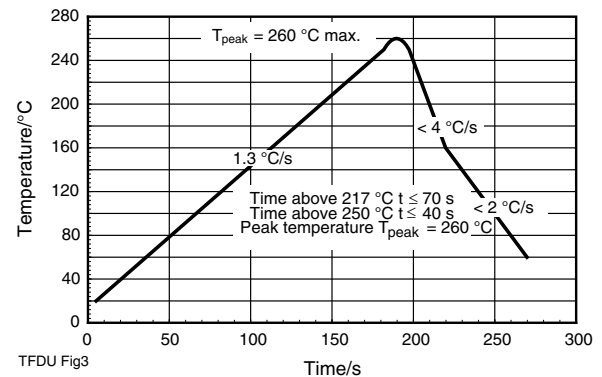


Fig. 3 - RTS Recommendation

Wave Soldering

For TFDUxxxx and TFBSxxxx transceiver devices and the TOIM4232, TOIM5232 endecs wave soldering is not recommended.

Manual Soldering

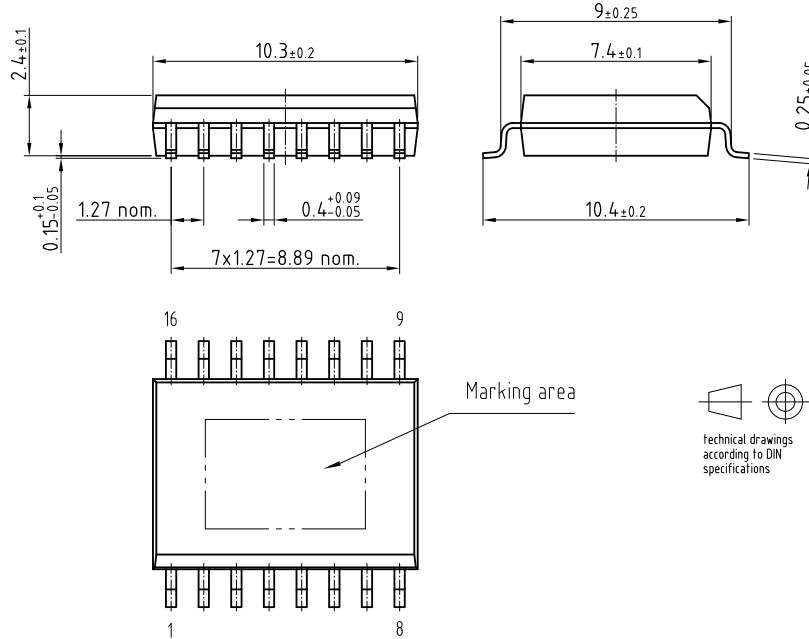
Manual soldering is the standard method for lab use. However, for a production process it cannot be recommended because the risk of damage is highly dependent on the experience of the operator. Nevertheless, we added a chapter to the above mentioned application note, describing manual soldering and desoldering.

Storage

The storage and drying processes for the endec TOIM4232 are equivalent to MSL3.

The data for the drying procedure is given on labels on the packing and also in the application note "Taping, Labeling, Storage and Packing".

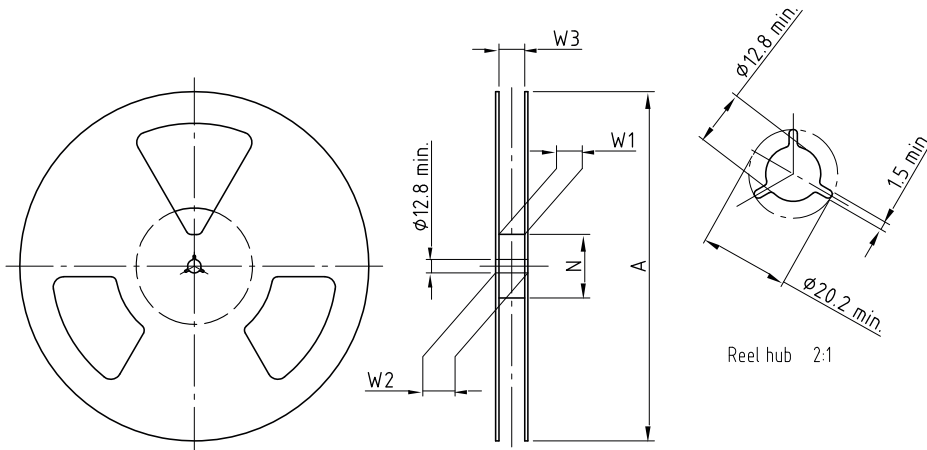
PACKAGE DIMENSIONS in millimeters



Drawing-No.: 6.541-5072.01-4
Issue: 2 ; 19.05.08
13011

technical drawings according to DIN specifications

REEL DIMENSIONS in millimeters



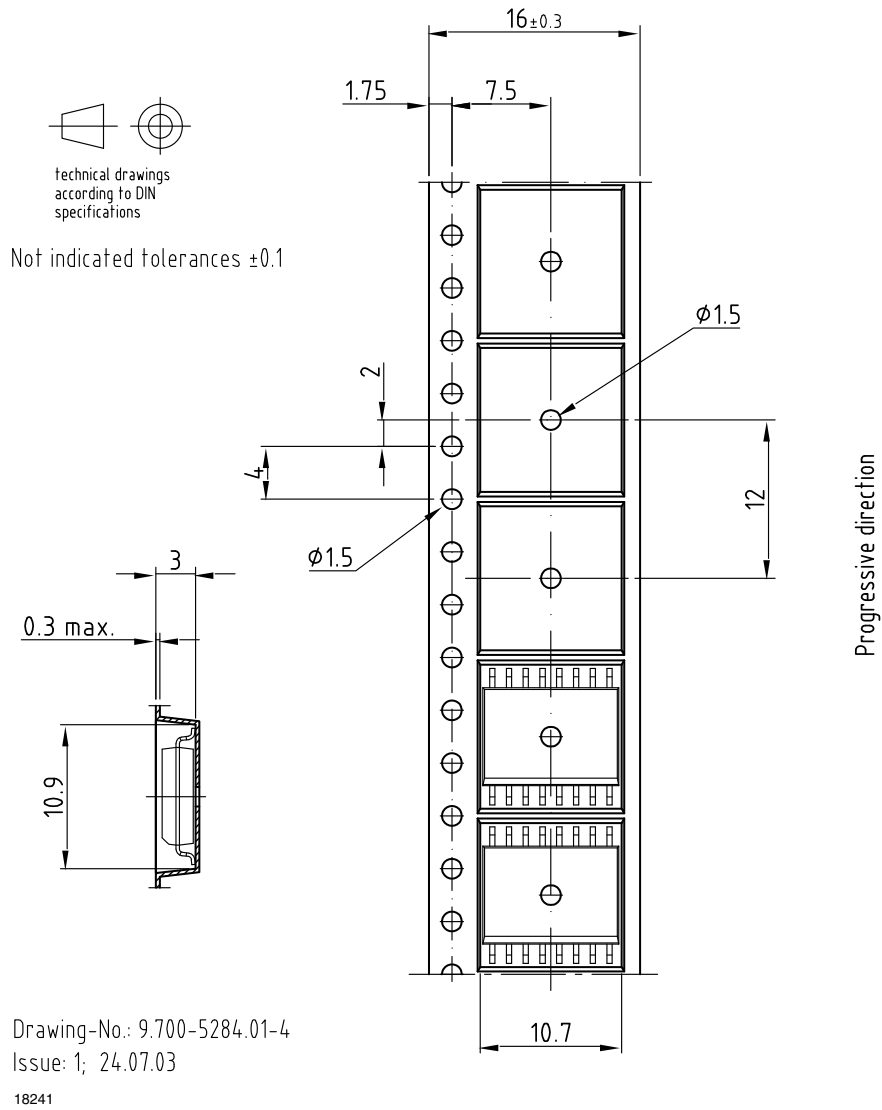
Drawing-No.: 9.800-5090.01-4
Issue: 1; 29.11.05
14017

Form of the leave open of the wheel is supplier specific.
Dimension acc. to IEC EN 60 286-3

technical drawings according to DIN specifications

TAPE WIDTH (mm)	A MAX. (mm)	N (mm)	W ₁ MIN. (mm)	W ₂ MAX. (mm)	W ₃ MIN. (mm)	W ₃ MAX. (mm)
16	330	50	16.4	22.4	15.9	19.4

TAPE DIMENSIONS in millimeters



TOIM4232 (TOIM5232) ENDEC - DECODER INTERFACE PROGRAMMING AND DATA TRANSMISSION

Operation and programming of the TOIM4232 and TOIM5232 interface devices are described below. Figure 4 shows the basic circuit design with 3 blocks: the RS232 to 3 V logic level shifter, the encoder/decoder (endec) circuit and the transceiver to build a dongle for RS232 IrDA

extension. U1 is the level shifter to convert the RS232 logic levels to unipolar 3 V logic; U2 is the encoder/decoder Interface (endec) converting the NRZ - RS232 logic to IrDA RZI - logic. The transceiver U3 transmits and receives IrDA-compliant optical signals.

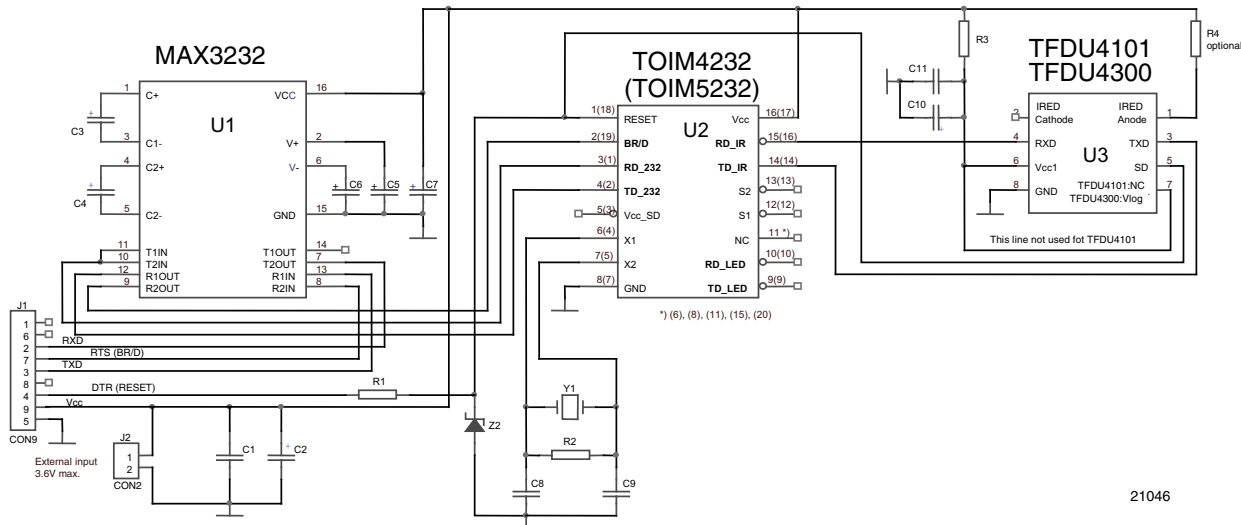


Fig. 4 - Circuit Diagram of the Demo Board

CIRCUIT DESCRIPTION

This circuit demonstrates the operation of an SIR IrDA transceiver module. The transceiver U3 (e.g., as shown the TFDU4101 or TFDU4300 or any other) converts the digital electrical input signal to an optical output signal to be transmitted, receives the optical signal, and converts these to electrical digital signals. While the IrDA physical layer protocol transmits only the “0” represented by a pulse with a “Return to Zero Inverted (RZI)” logic, the RS232 protocol needs a “No Return to Zero (NRZ)” representation. This decoding/encoding process is done by U2, an interface circuit stretching the received pulses and shortening the pulses to be transmitted according to the IrDA physical layer conditions. U1 interfaces the RS232 logic bipolar levels to the 3 V logic of the endec U2. The board is connected by CON9 to the RS232 port (of a computer or other equipment). The basic IrDA transmission speed is 9600 bit/s. This is the default state of the endec in power-on condition. Also, activating the reset line at pin 1 (18) will set the device to this basic state.

Note: The first pin number refers to TOIM4232; the second number in brackets refers to TOIM5232. The crystal Y1 controls the timing of the endec as a clock reference. The outputs S1 and S2 are programmable outputs for control operations and the outputs RD_LED and TD_LED can drive LEDs for indicating data flow.

PROGRAMMING THE ENDEC

For decoding data rates other than the default, the endec is to be programmed to set the internal counters and timers. To switch the endec from the data transfer mode to the bit rate programming mode, the input BR/D, pin 2 (19) is set active high (BR/D = “1”). In this case the TOIM5232 interprets the 7 LSBs at the TD_232 input as a control word. The operating bit rate will change to its supposedly new rate when the BR/D returns back to low (“0”). Set the UART to 8 bit, no parity, 1 stop bit.

The control byte consists of 8 bit after the start bit (STA, which is “0”). Keep in mind that the order is LSB first, MSB last.

The diagram in figure 5 shows the programming byte “0-1010-1100” in the order

STA, B0, B1, B2, B3, S0, S1, S2, X. This order is from right to left in table 1. B0 is sent first as LSB (see figure 5).

The four least significant bits are responsible for the data rate according to table 2 while the four higher bits are for setting the IrDA pulse duration (S0), and the two outputs of the Endec S1 and S2. Bit 8 is not used.

TABLE 1 - CONTROL BYTE (8 BIT)								
FIRST CHARACTER				SECOND CHARACTER				STA
X	S2	S1	S0	B3	B2	B1	B0	0
MSB							LSB	
Example								
0	0	1	1	0	1	0	1	0
In the oscilloscope that will be shown in the reserved order with LSB first, see figure 5.								
STA	FIRST CHARACTER			SECOND CHARACTER				
0	B0	B1	B2	B3	S0	S1	S2	X
	LSB							MSB
Example								
0	1	0	1	0	1	1	0	0

X: do not care

S1, S2: user-programmable bit to program the outputs S1 and S2. In the example, S1 is set active, and S2 is inactive.

S0: IrDA pulse select

S0 = (1): 1.627 µs output

S0 = (0): 3/16 bit time pulses, not recommended

B0 to B3: baud rate select words according to the following table 2 below.

TABLE 2 - TRANSMISSION RATE SELECT WORDS					
B3	B2	B1	B0	HEX	BIT RATE
0	0	0	0	0	115.2 kHz
0	0	0	1	1	57.6 kHz
0	0	1	0	2	38.4 kHz
0	0	1	1	3	19.2 kHz
0	1	0	0	4	14.4 kHz
0	1	0	1	5	12.8 kHz
0	1	1	0	6	9.6 kHz
0	1	1	1	7	7.2 kHz
1	0	0	0	8	4.8 kHz
1	0	0	1	9	3.6 kHz
1	0	1	0	A	2.4 kHz
1	0	1	1	B	1.8 kHz
1	1	0	0	C	1.2 kHz

Bold: see example

Note

- IrDA standard only supports 2.4 kbit/s, 9.6 kbit/s, 19.2 kbit/s, 57.6 kbit/s, and 115.2 kbit/s (3.6864 MHz clock). Doubling the baud rates is permissible by doubling the clock frequency.

In figure 5 the programming sequence is shown for a bit rate of 12.8 kbit/s.

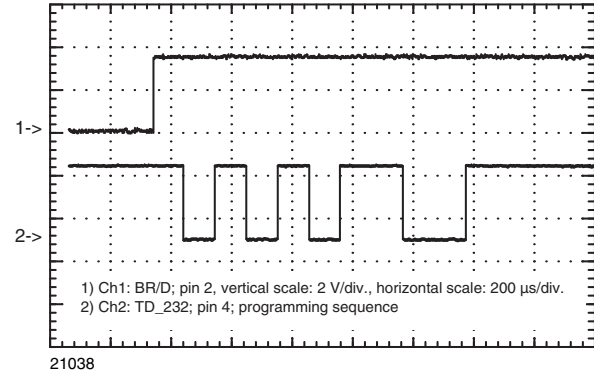


Fig. 5 - Programming sequence for setting the endec to a bit rate of 12.8 kbit/s. After setting BR/D high (Ch1), the programming sequence with the control byte (Ch2) is applied to TD_232, pin 4.

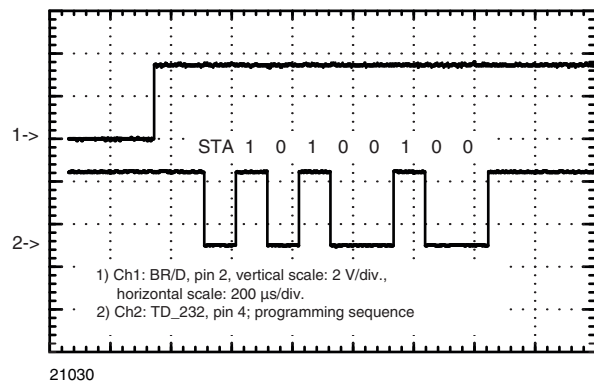


Fig. 6 - Programming sequence for setting the endec to a bit rate of 12.8 kbit/s as in figure 5 but with a 3/16 bit pulse duration (S0 = "0").

EXAMPLE								
0	0	1	0	0	1	0	1	0
MSB							LSB	STA

When correctly programmed, the endec shortens the pulse to be transmitted from the full bit duration to either 3/16 of the bit length or to 1.627 µs (which is 3/16 of the 115.2 kbit/s bit duration). For power saving, the short pulse is recommended.

The received optical pulse shows in case of most of the Vishay SIR transceivers, constant pulse duration. The Endec stretches that to the correct bit time according the bit rate setting. This is shown in the following chapters.

TRANSMIT (TXD) CHANNEL

Figure 7 shows the transmission in the default mode. For data transfer, the endec is set to that mode by BR/D = “0”. In the examples “6” is always transmitted (binary “0000110”). The “0” is represented in the IrDA protocol by an optical pulse. Also here the LSB is transmitted first after the start bit. “1” is not transmitted.

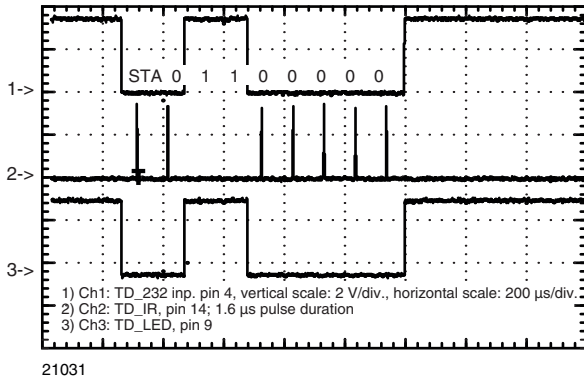


Fig. 7 - Data Transmission with 9.6 kbit/s,
1.627 µs Pulse Duration

Channel 1 shows the signal from the RS232 port already converted to 3 V logic by U1. The endec encodes that signal to the RZI IrDA format where a “0” is represented by a pulse. That is the trace of channel 2. This output is connected to the TXD input of the transceiver and this signal is transmitted as optical output signal. Channel 3 is the signal for an indicator lamp connected to the TD_LED driver output. Use 180 Ω serial resistor to supply voltage for limiting the current through the LED (not shown in the circuit diagram). When using the (not recommended) 3/16-bit pulse width the oscillogram looks like figure 8.

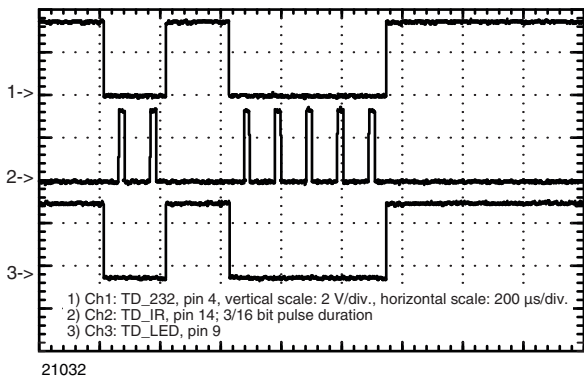


Fig. 8 - Data Transmission with the Setting 9.6 kbit/s,
3/16 bit Pulse Duration (19.5 µs)

The transmission with the highest SIR bit rate of 115.2 bit/s looks like what is shown in figure 9. However, the horizontal time scale is different.

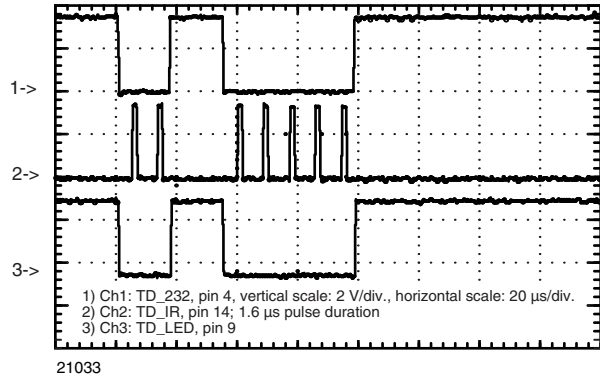


Fig. 9 -
Data transmission with the setting 115.2 kbit/s, 1.627 µs pulse duration. By definition, the pulse duration of 1.627 µs is identical to the 3/16-bit pulse width.

RECEIVE (RXD) CHANNEL

In the default 9600 bit/s mode the signals will look like those shown in figure 10 and figure 11.

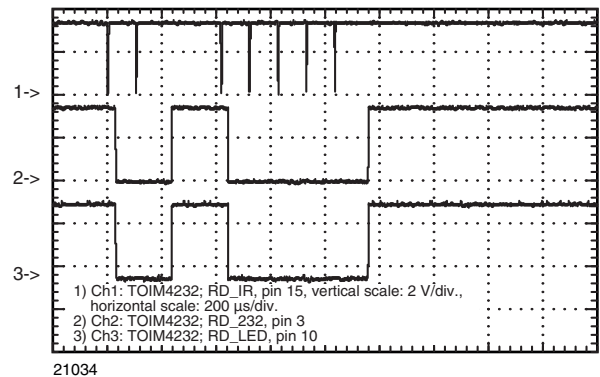


Fig. 10 - Data Reception with the Setting 9.6 kbit/s.
Short RXD Pulse.

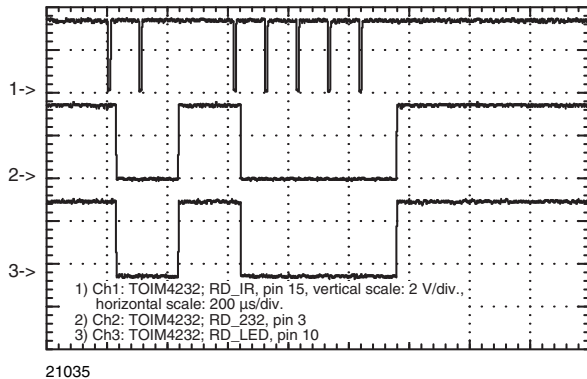


Fig. 11 - Data Reception with the Setting 9.6 kbit/s. Same as in Figure 10, extended Pulse Duration.

The endec stretches the received pulses of about 2 μs duration from the transceiver output (figure 10, channel 1) independent of the pulse duration to the full bit width generating NRZ code (channel 2). Channel 3 is the signal for the indicator lamp.

As shown in figure 11, channels 2 and 3, the final NRZ signal is identical to figure 10, even when longer pulses are received.

In the 115.2 kbit/s mode the signals will look like those shown in figure 10 and figure 11. The difference is just the time scale. It also indicates the delay of the decoded channel 2 vs. channel 1.

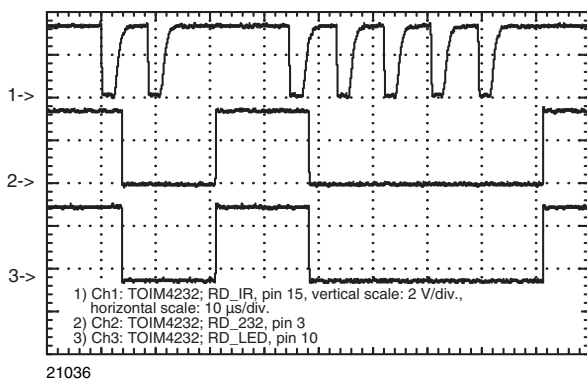


Fig. 12 - Data reception with the setting 115.2 kbit/s

Channel 1 shows the signal from the transceiver. In this case it is TFDU4100 with unsymmetrical switching times. TFDU4100 (obsolete) used an open collector output with an internal load resistor. That caused a slow trailing edge (but fast enough for all applications). The later generations are using tri-state outputs with push-pull drivers with symmetrical pulse switching times. All Vishay IrDA transceivers exhibit constant output pulse duration in SIR mode of about 2 μs independent of the duration of the optical input pulse.

“ECHO-ON” OR “ECHO-OFF” AND “LATENCY ALLOWANCE”

During transmission, the receiver inside a transceiver package is exposed to very strong irradiance of the transmitter, which causes overload conditions in the receiver circuit. After transmission it takes some time to recover from this condition and return to the specified sensitivity.

During this time the receiver is in an unstable condition, and at the output unexpected signals may arise. Also, during transmission under overload conditions the receiver may show signals on the RXD channel that are similar to or identical with the transmitted signal. To get clean or at least specified conditions for the receive channel during transmission, different terms were defined. The time to allow the receiver to recover from overload conditions is the latency allowance or shorter, just the specified latency. This is covered by the IrDA physical layer specification and is a maximum of 10 ms. IrDA specifies shorter negotiable latency. In SIR the minimum is 0.5 ms. This includes software latency. Transceivers are in general below 0.3 ms. In the first generations, some suppliers did not care for the behavior of the RXD output of the transceivers during transmission and latency time. The software is able to handle that. The easiest way is to clean up the receiver channel after sending the last pulse and waiting for the latency period.

Later, many transceivers that block the RXD channel during transmission and during the latency period were released to the market. This behavior is called “Echo-off”. Unfortunately, some OEMs like to use the signal from the RXD channel during transmission, as a self-test feature for testing the device on board without using the optical domain. Therefore, many new devices have been developed to echo the TXD input signal at the RXD output. Such behavior is called “echo-on”.

Some software developed for “echo-off” applications is not able to receive and understand the signals from echo-on devices correctly.

Therefore, an add-on to the circuit shown in figure 4 was generated to suppress the echo from the receiver during transmission. This modification is shown in figure 13.

During transmission, the signal from the RXD output of the transceiver is just gated by the transmit signal, (see the oscilloscope picture in figure 14).

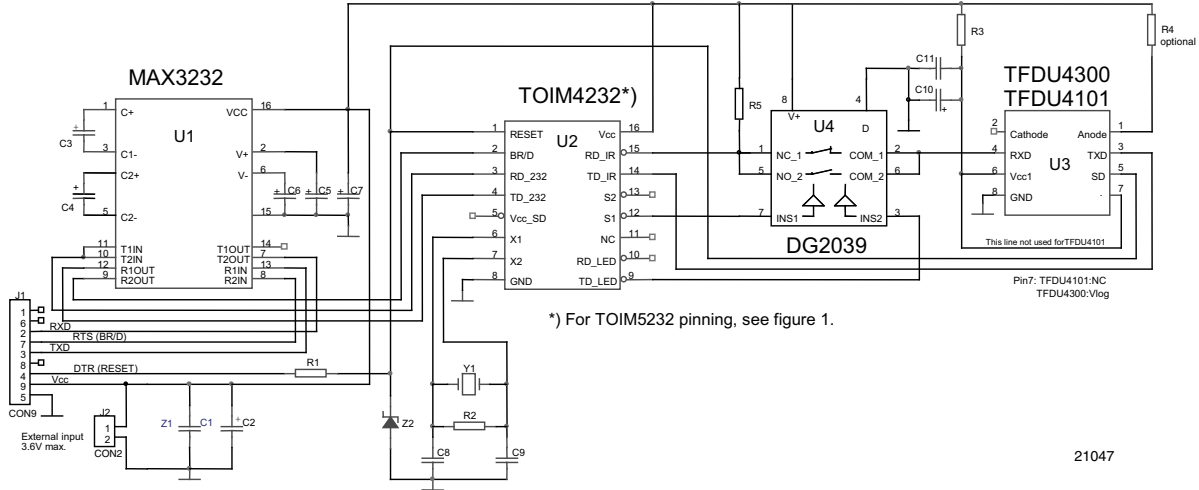


Fig. 13 - Demo Board Circuit with Echo-Suppression to be Used for Echo-On and Echo-Off Transceivers.

Additionally, with the programmable output S1 of the endec the echo suppression feature can be switched on and off for testing. The default mode is echo-off. To enable the echo, S1 is to be set inactive/low. (See the chapter for programming the TOIM4232, TOIM5232).

The oscilloscope diagrams are shown in figure 14. Channel 2 shows the echo signal on the RXD output of the TFDU4101 transceiver during transmission (Note: TFDU4300 is an echo-off design and would not show this).

Channel 1 is the signal used for gating the path from the transceiver RXD output to the endec. On channel 3 the signal at the input of the endec is shown with a residual signal. Finally, the output to the RS232 port, RD_232, is clean without any noise signal.

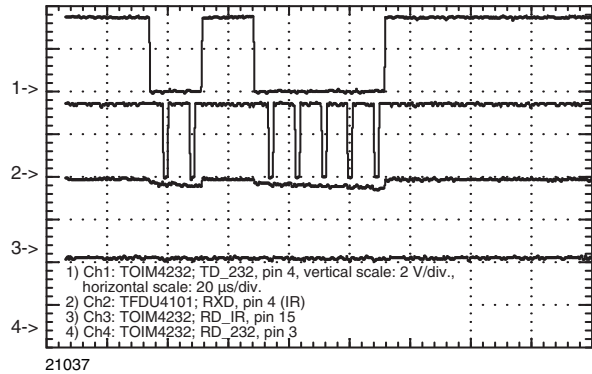


Fig. 14 - Echo-Suppression



Disclaimer

ALL PRODUCT, PRODUCT SPECIFICATIONS AND DATA ARE SUBJECT TO CHANGE WITHOUT NOTICE TO IMPROVE RELIABILITY, FUNCTION OR DESIGN OR OTHERWISE.

Vishay Intertechnology, Inc., its affiliates, agents, and employees, and all persons acting on its or their behalf (collectively, "Vishay"), disclaim any and all liability for any errors, inaccuracies or incompleteness contained in any datasheet or in any other disclosure relating to any product.

Vishay makes no warranty, representation or guarantee regarding the suitability of the products for any particular purpose or the continuing production of any product. To the maximum extent permitted by applicable law, Vishay disclaims (i) any and all liability arising out of the application or use of any product, (ii) any and all liability, including without limitation special, consequential or incidental damages, and (iii) any and all implied warranties, including warranties of fitness for particular purpose, non-infringement and merchantability.

Statements regarding the suitability of products for certain types of applications are based on Vishay's knowledge of typical requirements that are often placed on Vishay products in generic applications. Such statements are not binding statements about the suitability of products for a particular application. It is the customer's responsibility to validate that a particular product with the properties described in the product specification is suitable for use in a particular application. Parameters provided in datasheets and/or specifications may vary in different applications and performance may vary over time. All operating parameters, including typical parameters, must be validated for each customer application by the customer's technical experts. Product specifications do not expand or otherwise modify Vishay's terms and conditions of purchase, including but not limited to the warranty expressed therein.

Except as expressly indicated in writing, Vishay products are not designed for use in medical, life-saving, or life-sustaining applications or for any other application in which the failure of the Vishay product could result in personal injury or death. Customers using or selling Vishay products not expressly indicated for use in such applications do so at their own risk and agree to fully indemnify and hold Vishay and its distributors harmless from and against any and all claims, liabilities, expenses and damages arising or resulting in connection with such use or sale, including attorneys fees, even if such claim alleges that Vishay or its distributor was negligent regarding the design or manufacture of the part. Please contact authorized Vishay personnel to obtain written terms and conditions regarding products designed for such applications.

No license, express or implied, by estoppel or otherwise, to any intellectual property rights is granted by this document or by any conduct of Vishay. Product names and markings noted herein may be trademarks of their respective owners.