

Low drop dual power operational amplifiers

Features

- Output current up to 1 A
- Operates at low voltages
- Single or split supply
- Large common-mode and differential-mode range
- Low input-offset voltage
- Ground compatible inputs
- Low saturation voltage
- Thermal shutdown
- Clamp diode

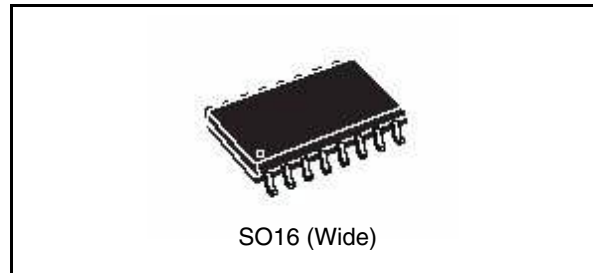

Description

The L2720W is a monolithic integrated circuit in SO16 (Wide) package, intended for use as a power operational amplifier in a wide range of applications including servo amplifiers and power supplies.

It is particularly suitable for driving coils, inductive loads and for use in motors.

The high gain and high output power capability provide superior performance whenever an operational amplifier/power booster combination is required.

Table 1. Device summary

Order code	Package	Packaging
L2720W	SO16 (Wide)	Tube
L2720W13TR	SO16 (Wide)	Tape and reel

1 Connection diagrams

Figure 1. Block diagram

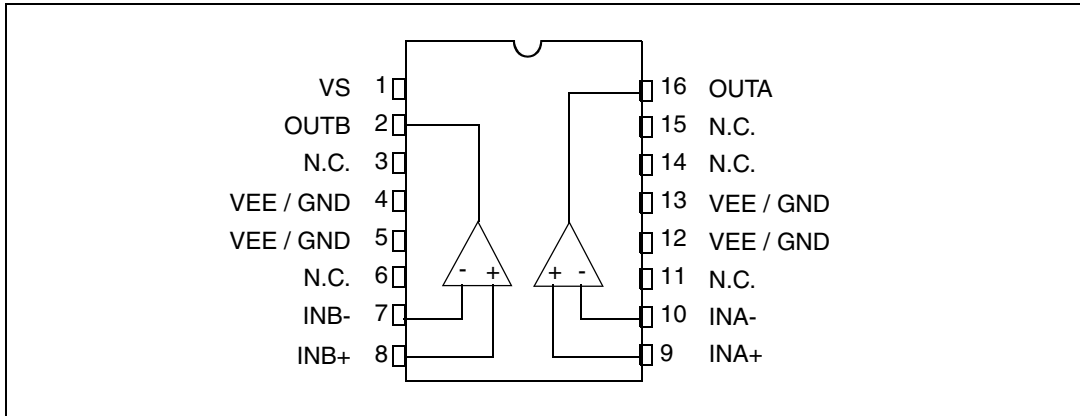
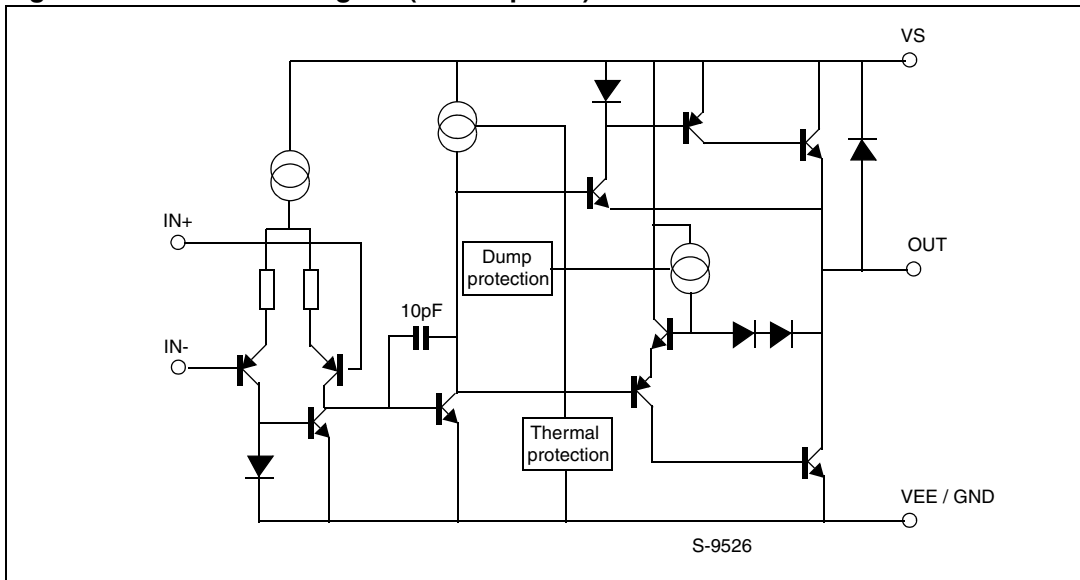

Figure 2. Schematic diagram (one amplifier)



2 Pin out

Figure 3. Pin connection (top view)

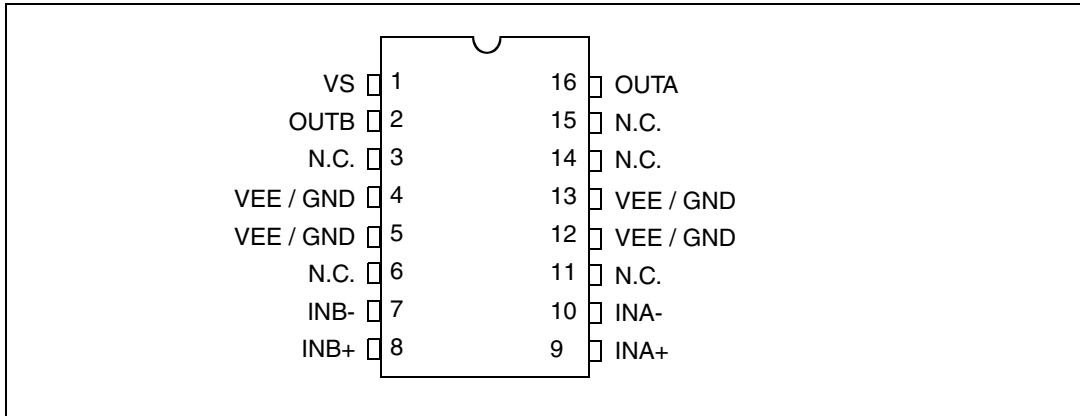

Table 2. Pin description

Pin	Name	Type	Description
1	VS	Power	Power supply positive
2	OUTB	Output	Amplifier B output
3	N.C.	-	No internal connection
4	VEE / GND	Power	Power supply negative or ground
5	VEE / GND	Power	Power supply negative or ground
6	N.C.	-	No internal connection
7	INB-	Input	Amplifier B input
8	INB+	Input	Amplifier B input
9	INA+	Input	Amplifier A input
10	INA-	Input	Amplifier A input
11	N.C.	-	No internal connection
12	VEE / GND	Power	Power supply negative or ground
13	VEE / GND	Power	Power supply negative or ground
14	N.C.	-	No internal connection
15	N.C.	-	No internal connection
16	OUTA	Output	Amplifier A output

3 Electrical specifications

3.1 Absolute maximum ratings

Table 3. Absolute maximum ratings

Pin/symbol	Description	Min	Max	Unit
V_S	Supply voltage	-	28	V
V_{S-PK}	Peak supply voltage (50 ms)	-	50	V
V_i	Input voltage range	-	V_S	V
V_i	Differential input voltage range	-	$\pm V_S$	V
I_O	DC output current	-	1	A
I_{O-PK}	Peak output current (non repetitive)	-	1.5	A
T_{op}	Operating ambient temperature range	-40	125	°C
T_{stg}, T_j	Storage and junction temperature range	-40	150	°C

3.2 Thermal data

Table 4. Thermal data

Device	Parameter	Min	Typ	Max	Unit
	$R_{th\ j-amb}$ Thermal resistance junction to ambient ⁽¹⁾	-	65	-	°C/W
	$R_{th\ j-case}$ Thermal resistance junction to case pins ⁽²⁾	-	12	-	°C/W

1. On double layer PCB with 4 cm² copper dissipating area

2. Referred to pins 4, 5, 12 and 13.

3.3 Recommended operating conditions

Table 5. Recommended operating conditions

Symbol	Parameter	Min	Typ	Max	Unit
V_S	Positive single power supply	4.0	-	28	V
	Positive split power supply	2.0	-	14	V
V_E	Negative single power supply	-	0	-	V
	Negative split power supply	-2.0	-	-14	V
V_{IN}	Input voltage	-	-	V_S to V_E	V

3.4 Electrical characteristics

The electrical specifications in [Table 6](#) below are given for operation under the conditions $V_S = 24\text{ V}$, $T_{\text{amb}} = -40\text{ °C}$ to 125 °C and RI connected to GND, unless otherwise specified

Table 6. Electrical characteristics

Symbol	Parameter	Conditions	Min	Typ	Max	Unit	
I_s	Quiescent current	$V_O = V_S / 2$	$T_{\text{amb}} = 25\text{ °C}$	-	10	15	mA
			-	-	10	18	
I_{ib}	Input bias current	$V_{\text{CM}} = 0$	$T_{\text{amb}} = 25\text{ °C}$	-	0.2	1	μA
			-	-	0.2	1	
I_{ob}	Input offset current	$V_{\text{CM}} = 0$	$T_{\text{amb}} = 25\text{ °C}$	-	-	100	nA
			-	-	-	100	
V_{OS}	Input offset voltage	$T_{\text{amb}} = 25\text{ °C}$	-	-10	-	10	mV
			-	-10	-	10	
$\Delta V_{\text{OS}}/\Delta T$	Average temperature coefficient of V_{OS}	-	-	20	-	$\mu\text{V}/\text{°C}$	
SR	Slew rate	$V_{\text{in}} = -10\text{ V}$ to $+10\text{ V}$, $R_L = 2\text{ k}\Omega$, $C_L = 100\text{ pF}$, $A_v = -1$, $T_{\text{amb}} = 25\text{ °C}$	-	2	-	$\text{V}/\mu\text{s}$	
B	Gain-bandwidth product	-	-	1.2	-	MHz	
G_v	Open loop voltage gain	$f = 100\text{ Hz}$	70	80	-	dB	
		$f = 1\text{ kHz}$	-	60	-		
CMRR	Common mode rejection ratio	$f = 1\text{ kHz}$	66	84	-	dB	
SVRR	Supply voltage rejection ratio	$f = 100\text{ Hz}$ $R_G = 10\text{ k}\Omega$ $V_R = 0.5\text{ V}$	$V_S = 24\text{ V}$	-	70	-	dB
			$V_S = \pm 12\text{ V}$	60	75	-	
$V_{\text{DROP(H)}}$	Drop voltage high	$I_p = 100\text{ mA}$	$T_{\text{amb}} = 25\text{ °C}$	-	0.7	1	V
			-	-	0.8	1.5	
		$I_p = 1\text{ A}$	$T_{\text{amb}} = 25\text{ °C}$	-	1.0	1.5	
			-	-	1.1	1.5	
$V_{\text{DROP(L)}}$	Drop voltage low	$I_p = 100\text{ mA}$	$T_{\text{amb}} = 25\text{ °C}$	-	0.3	0.7	V
			-	-	0.4	1	
		$I_p = 1\text{ A}$	$T_{\text{amb}} = 25\text{ °C}$	-	0.5	1	
			-	-	1.3	1.5	
C_s	Channel separation	$f = 1\text{ kHz}$; $R_L = 10\text{ }\Omega$; $G_v = 30\text{ dB}$	$V_S = 24\text{ V}$	-	60	-	dB
			$V_S = 6\text{ V}$	-	60	-	
e_N	Input noise voltage	$B = 22\text{ Hz}$ to 22 kHz , $T_{\text{amb}} = 25\text{ °C}$	-	10	-	μV	

Table 6. Electrical characteristics (continued)

Symbol	Parameter	Conditions	Min	Typ	Max	Unit
I_N	Input noise current	$B = 22 \text{ Hz to } 22 \text{ kHz}$, $T_{\text{amb}} = 25 \text{ }^\circ\text{C}$	-	200	-	pA
ϕ_m	Phase margin	$R_L = 2 \text{ k}\Omega$, $C_L = 100 \text{ pF}$, $T_{\text{amb}} = 25 \text{ }^\circ\text{C}$	-	65	-	$^\circ\text{C}$
A_m	Gain margin	$R_L = 2 \text{ k}\Omega$, $C_L = 100 \text{ pF}$, $T_{\text{amb}} = 25 \text{ }^\circ\text{C}$	-	15	-	dB

3.5 Characterization curves

Figure 4. Quiescent current vs supply current

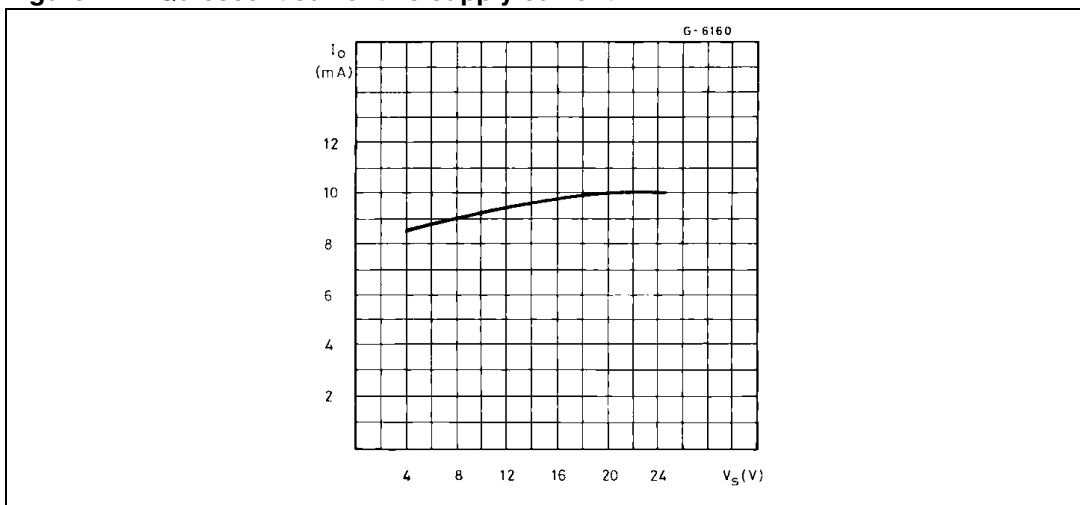

Figure 5. Open loop gain vs frequency

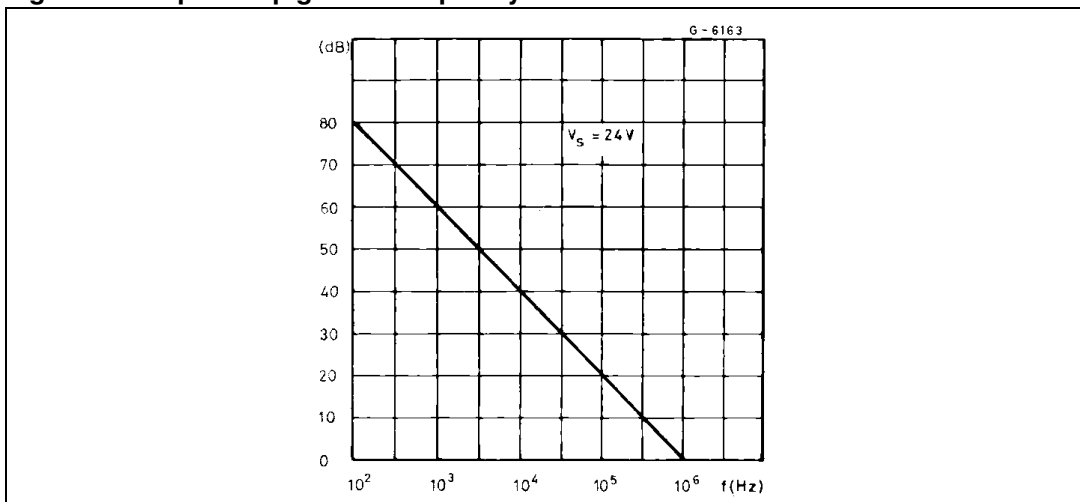

Figure 6. Common mode rejection vs frequency

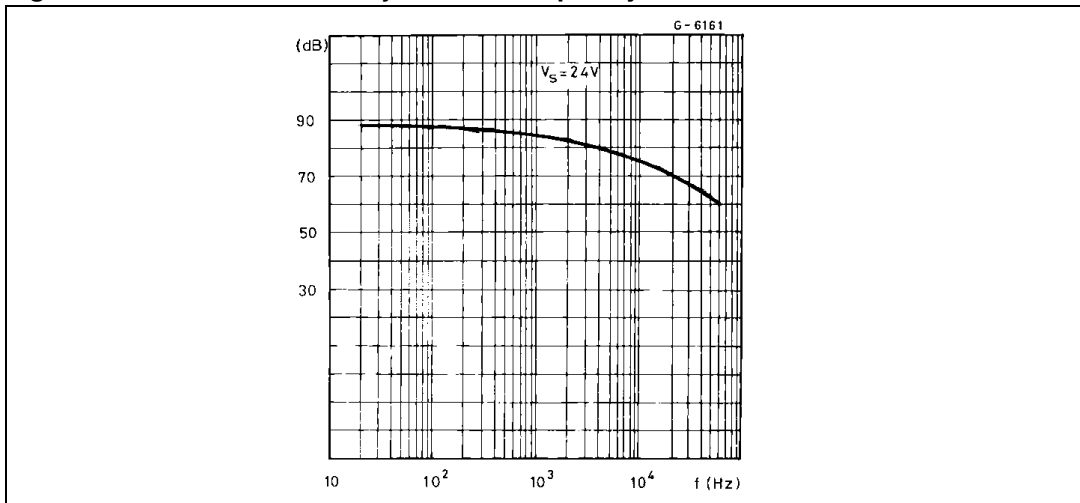

Figure 7. Output swing vs load current (Vs = ±5 V)

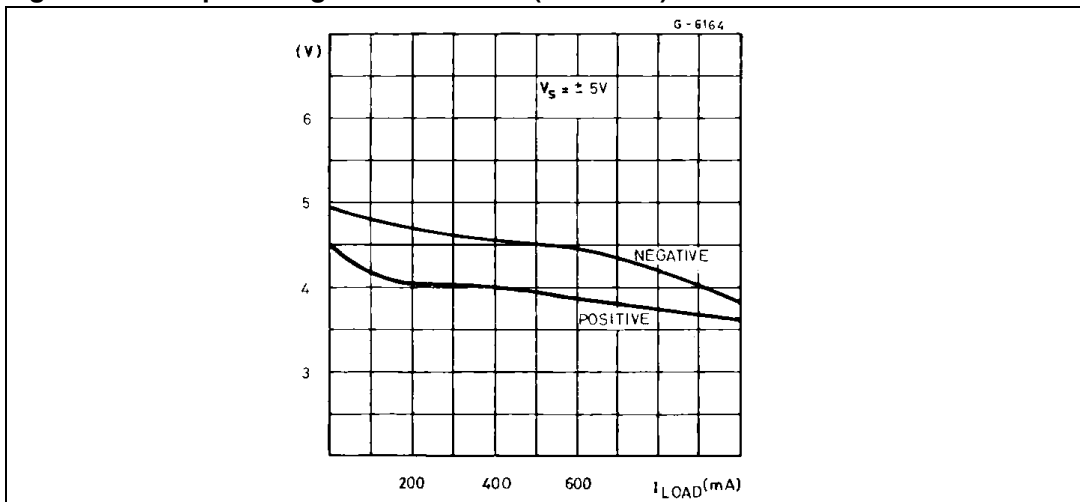

Figure 8. Output swing vs load current (Vs = ±12 V)

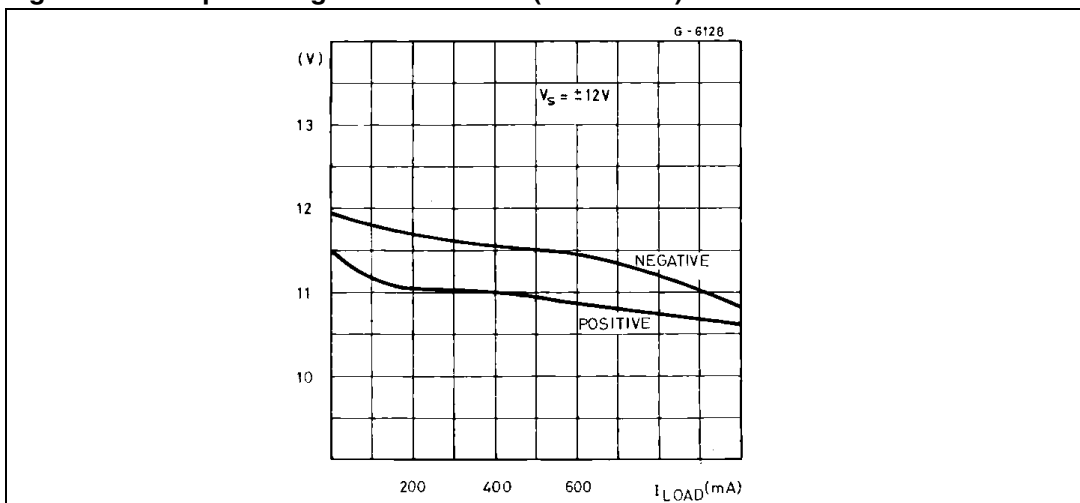

Figure 9. Supply voltage rejection vs frequency

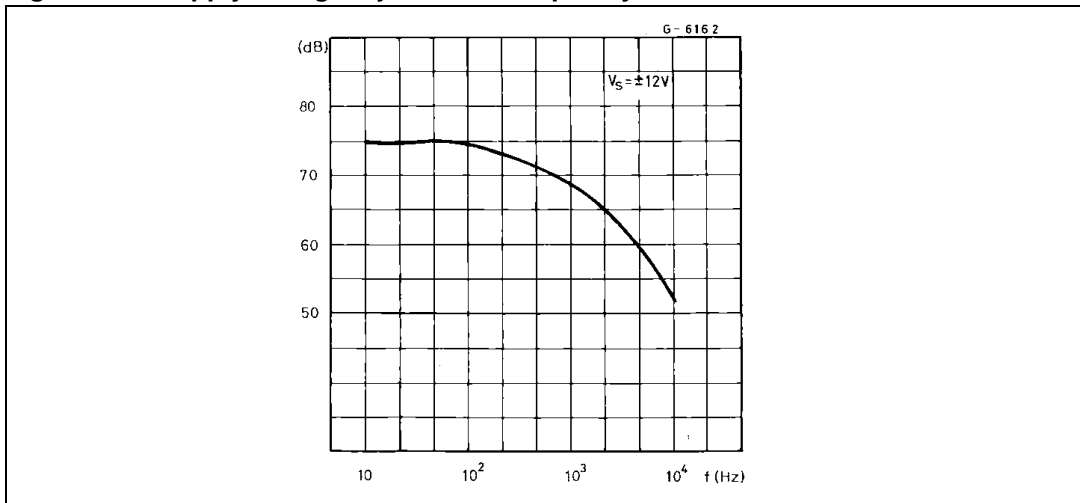

Figure 10. Channel separation vs frequency

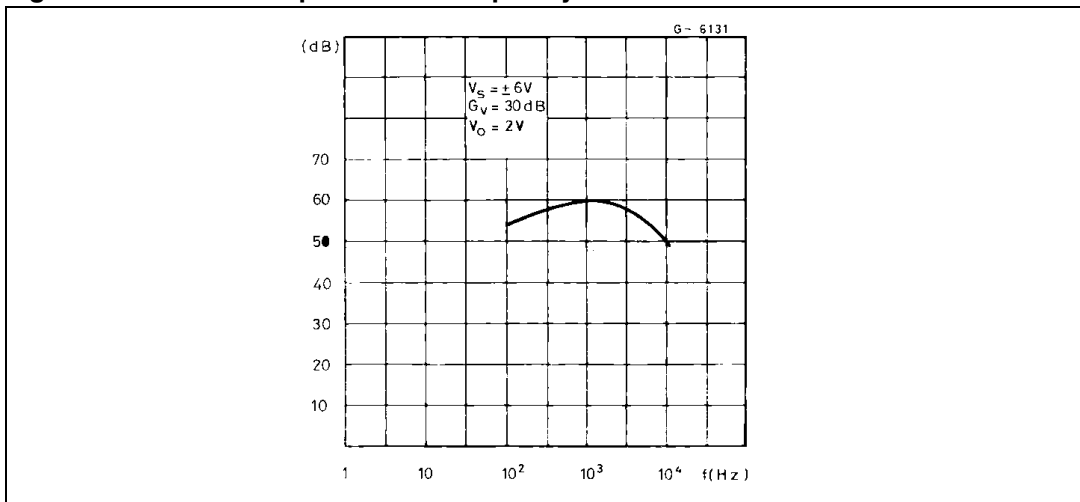

Figure 11. Voltage gain and phase vs frequency

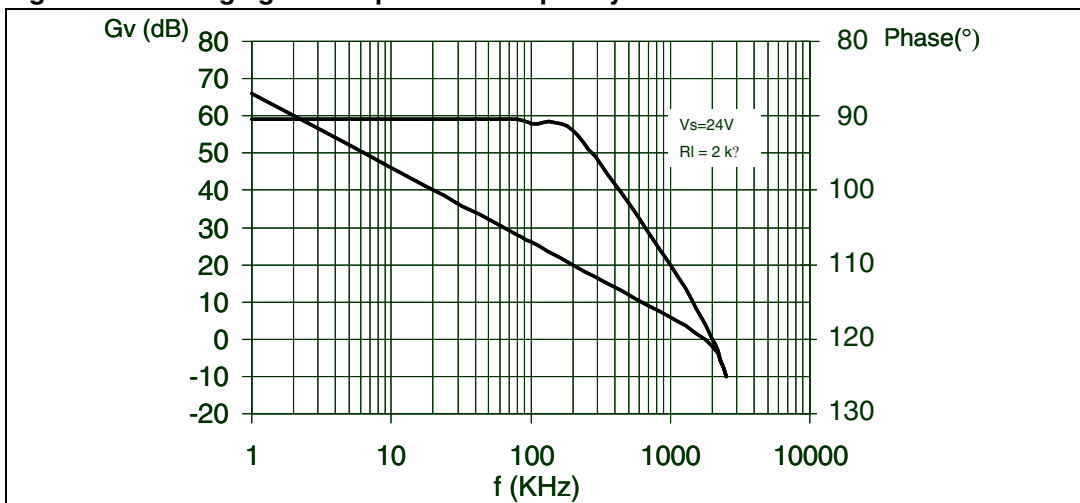
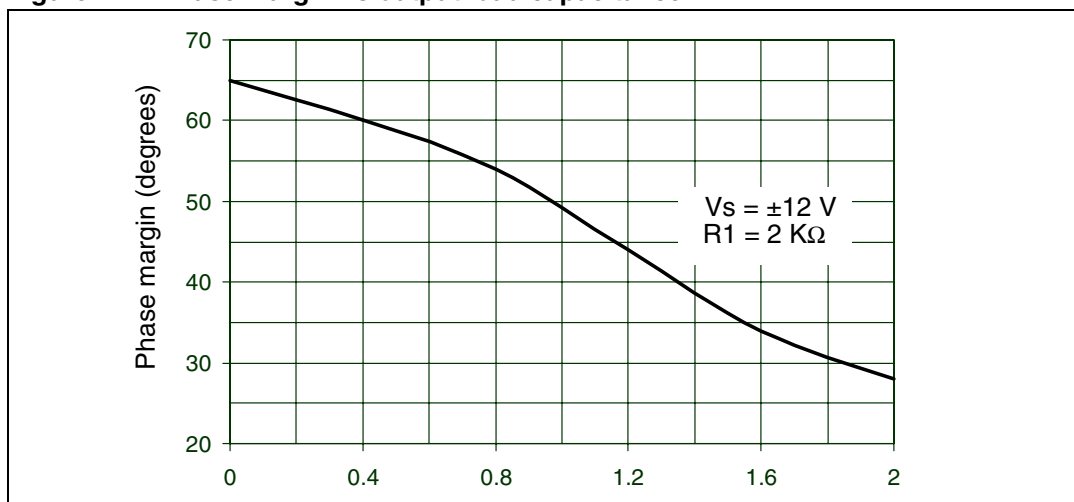

Figure 12. Phase margin vs output load capacitance



4 Package mechanical data

In order to meet environmental requirements, ST offers these devices in different grades of ECOPACK® packages, depending on their level of environmental compliance. ECOPACK® specifications, grade definitions and product status are available at: www.st.com. ECOPACK® is an ST trademark.

Figure 13. SO16 (Wide) mechanical data and package dimensions

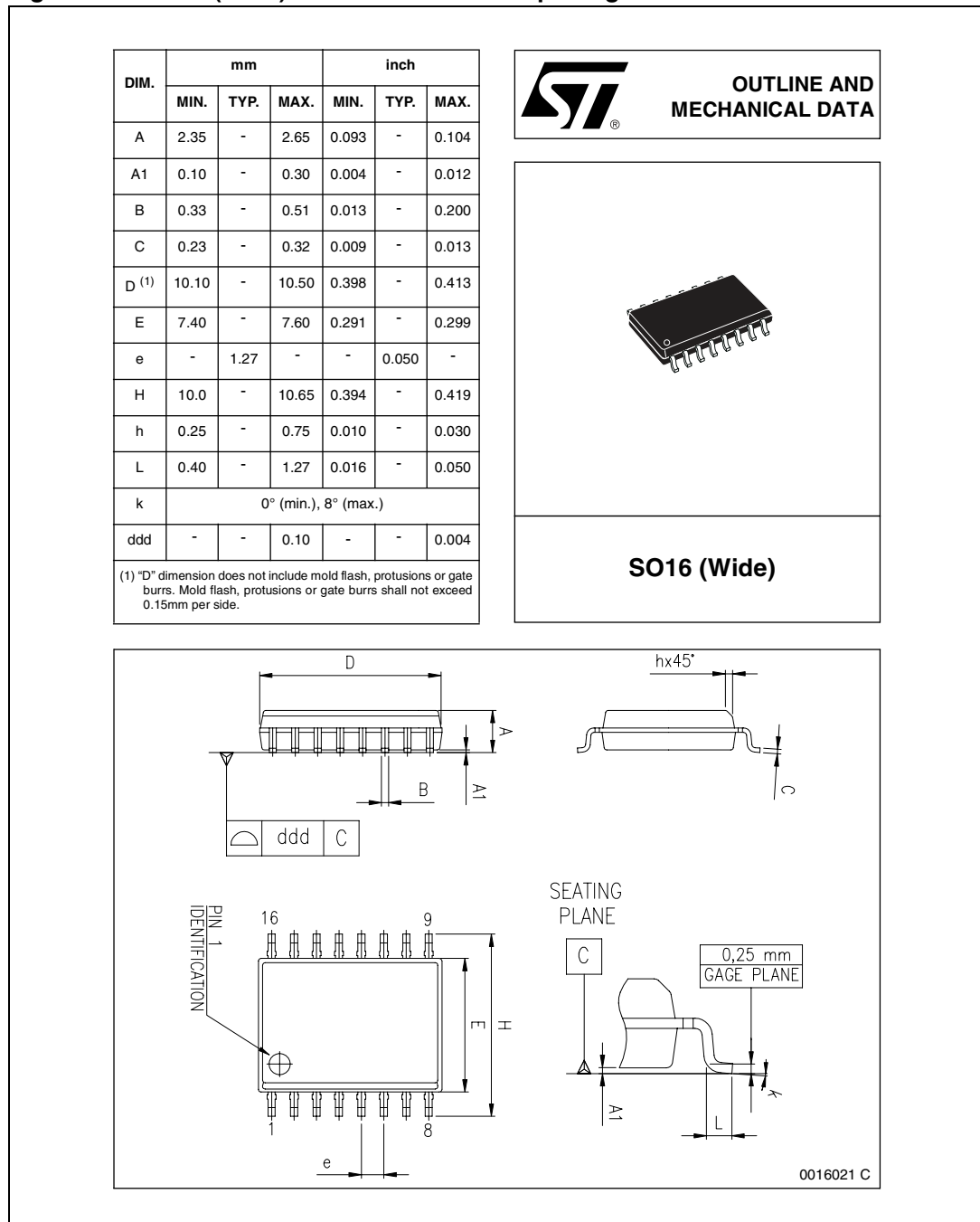

5 Revision history

Table 7. Document revision history

Date	Revision	Changes
04-Apr-2007	1	Initial release.
03-Sep-2010	2	Complete update and change in presentation

Please Read Carefully:

Information in this document is provided solely in connection with ST products. STMicroelectronics NV and its subsidiaries ("ST") reserve the right to make changes, corrections, modifications or improvements, to this document, and the products and services described herein at any time, without notice.

All ST products are sold pursuant to ST's terms and conditions of sale.

Purchasers are solely responsible for the choice, selection and use of the ST products and services described herein, and ST assumes no liability whatsoever relating to the choice, selection or use of the ST products and services described herein.

No license, express or implied, by estoppel or otherwise, to any intellectual property rights is granted under this document. If any part of this document refers to any third party products or services it shall not be deemed a license grant by ST for the use of such third party products or services, or any intellectual property contained therein or considered as a warranty covering the use in any manner whatsoever of such third party products or services or any intellectual property contained therein.

UNLESS OTHERWISE SET FORTH IN ST'S TERMS AND CONDITIONS OF SALE ST DISCLAIMS ANY EXPRESS OR IMPLIED WARRANTY WITH RESPECT TO THE USE AND/OR SALE OF ST PRODUCTS INCLUDING WITHOUT LIMITATION IMPLIED WARRANTIES OF MERCHANTABILITY, FITNESS FOR A PARTICULAR PURPOSE (AND THEIR EQUIVALENTS UNDER THE LAWS OF ANY JURISDICTION), OR INFRINGEMENT OF ANY PATENT, COPYRIGHT OR OTHER INTELLECTUAL PROPERTY RIGHT.

UNLESS EXPRESSLY APPROVED IN WRITING BY AN AUTHORIZED ST REPRESENTATIVE, ST PRODUCTS ARE NOT RECOMMENDED, AUTHORIZED OR WARRANTED FOR USE IN MILITARY, AIR CRAFT, SPACE, LIFE SAVING, OR LIFE SUSTAINING APPLICATIONS, NOR IN PRODUCTS OR SYSTEMS WHERE FAILURE OR MALFUNCTION MAY RESULT IN PERSONAL INJURY, DEATH, OR SEVERE PROPERTY OR ENVIRONMENTAL DAMAGE. ST PRODUCTS WHICH ARE NOT SPECIFIED AS "AUTOMOTIVE GRADE" MAY ONLY BE USED IN AUTOMOTIVE APPLICATIONS AT USER'S OWN RISK.

Resale of ST products with provisions different from the statements and/or technical features set forth in this document shall immediately void any warranty granted by ST for the ST product or service described herein and shall not create or extend in any manner whatsoever, any liability of ST.

ST and the ST logo are trademarks or registered trademarks of ST in various countries.

Information in this document supersedes and replaces all information previously supplied.

The ST logo is a registered trademark of STMicroelectronics. All other names are the property of their respective owners.

© 2010 STMicroelectronics - All rights reserved

STMicroelectronics group of companies

Australia - Belgium - Brazil - Canada - China - Czech Republic - Finland - France - Germany - Hong Kong - India - Israel - Italy - Japan - Malaysia - Malta - Morocco - Philippines - Singapore - Spain - Sweden - Switzerland - United Kingdom - United States of America

www.st.com