



# HUMIDITY SENSORS: TYPE HS12P, HS15P

## RELATIVE HUMIDITY SENSOR

### DESCRIPTION:

Non-refresh type humidity sensor made of polymer.

### FEATURES:

- Good long term reliability
- Cost effective performance
- HS15P water resistive
- Typical applications include humidity monitors, humidity controllers, air conditioners, humidifiers, dehumidifiers, automatic ventilation

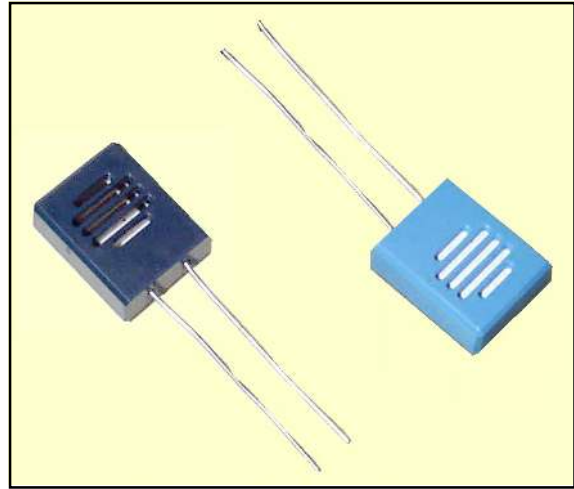

### DATA:

CODE	HS12P	HS15P
Operating Temperature	0 to 50°C	
Operating Humidity	20 to 90% RH (without condensing)	20 to 100% RH
Impedance at 25°C 50% RH	60 k ohm +/- 30 k ohm (+/- 5% RH)	
Rated Voltage	A.C. 1 V rms	
Rated Frequency	50 Hz to 1 kHz	
Consumption Power	0.3 mW	

### CODING:

HS12P: quick response type  
HS15P: water resistant type

### WARNING:

Use only within the specified limits.  
Do not disassemble and change any parts.  
Do not apply DC voltage or DC bias.  
Do not immerse into water or any solution.

### DIMENSIONS:

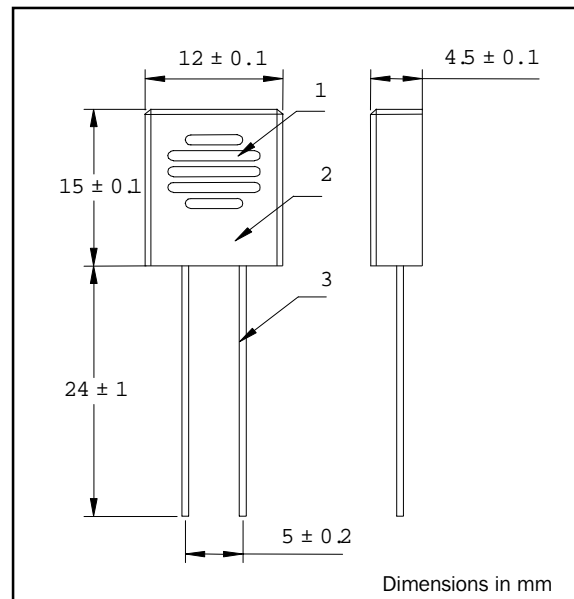

#### 1. Filter

2. Case ..... ABS: Dark blue (HS12P)  
..... Light blue (HS15P)

3. Lead wire ..... Sn-Pb plated Cu  
..... Diameter: 0.6mm



# HUMIDITY SENSORS: TYPE HS12P, HS15P

## RELATIVE HUMIDITY SENSOR

### TYPICAL HUMIDITY CURVE:

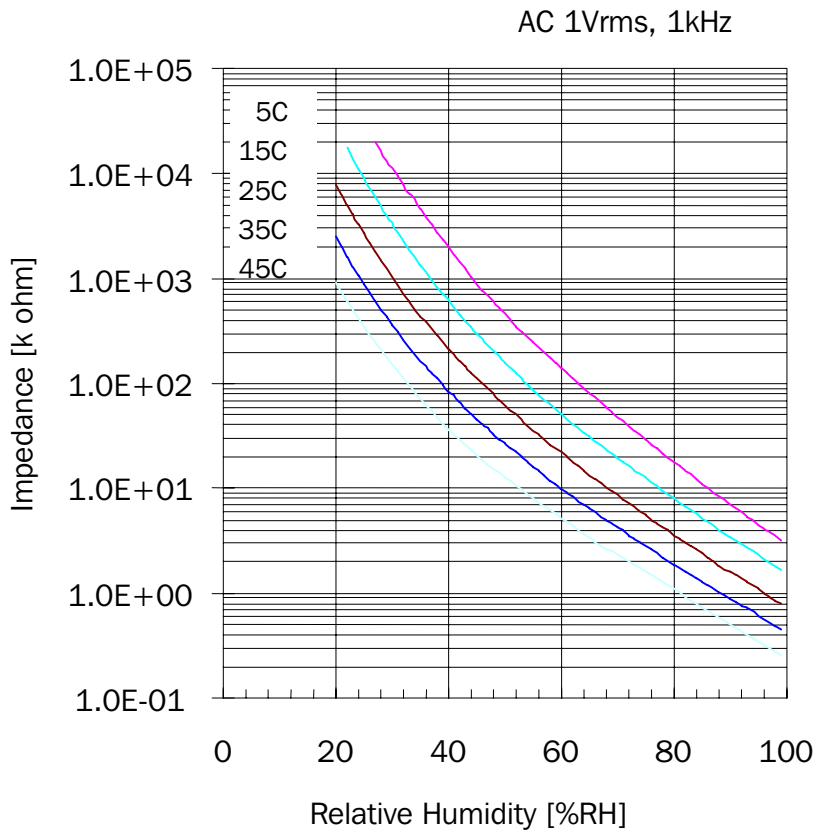

### TYPICAL RESPONSE CURVE:

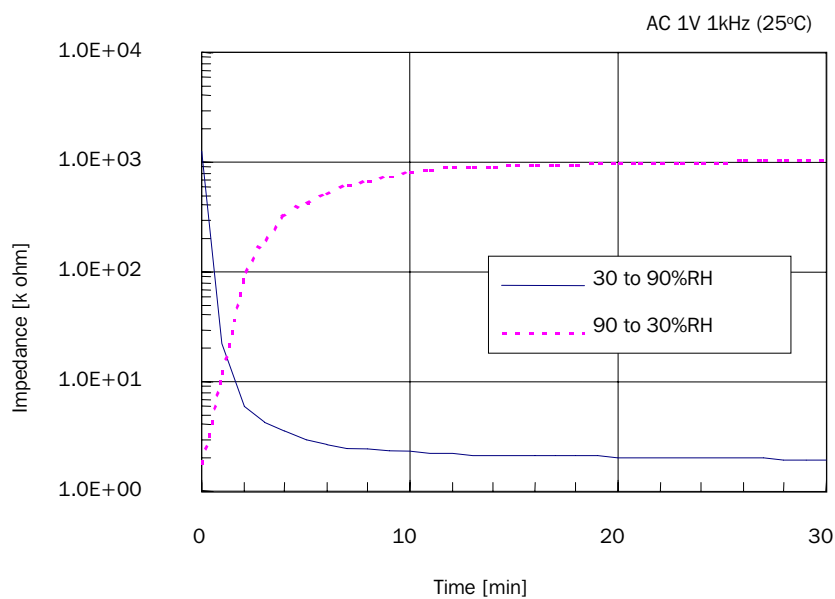

Data sheet D-HS12/15P-1