

## TPS650231 Power Management IC for Li-Ion Powered Systems

### 1 Features

- 1.7-A, 90% Efficient Step-Down Converter for Processor Core (VDCDC1)
- 1.2-A, Up to 95% Efficient Step-Down Converter for System Voltage (VDCDC2)
- 0.8-A, 92% Efficient Step-Down Converter for Memory Voltage (VDCDC3)
- 30-mA LDO and Switch for Real-Time Clock (VRTC)
- 2 × 200-mA General-Purpose LDO
- Dynamic Voltage Management for Processor Core
- Preselectable LDO Voltage Using Two Digital Input Pins
- Externally Adjustable Reset Delay Time
- Battery Backup Functionality
- Separate Enable Pins for Inductive Converters
- I<sup>2</sup>C™-Compatible Serial Interface
- 85- $\mu$ A Quiescent Current
- Low-Ripple PFM Mode
- Thermal Shutdown Protection
- Available in 40-Pin, 5-mm × 5-mm VQFN (RSB) or 49-Ball, 3-mm × 3-mm DSBGA (YFF) Package

### 2 Applications

- Smart Phones
- Netbooks and MIDs
- Portable Media Players

### 3 Description

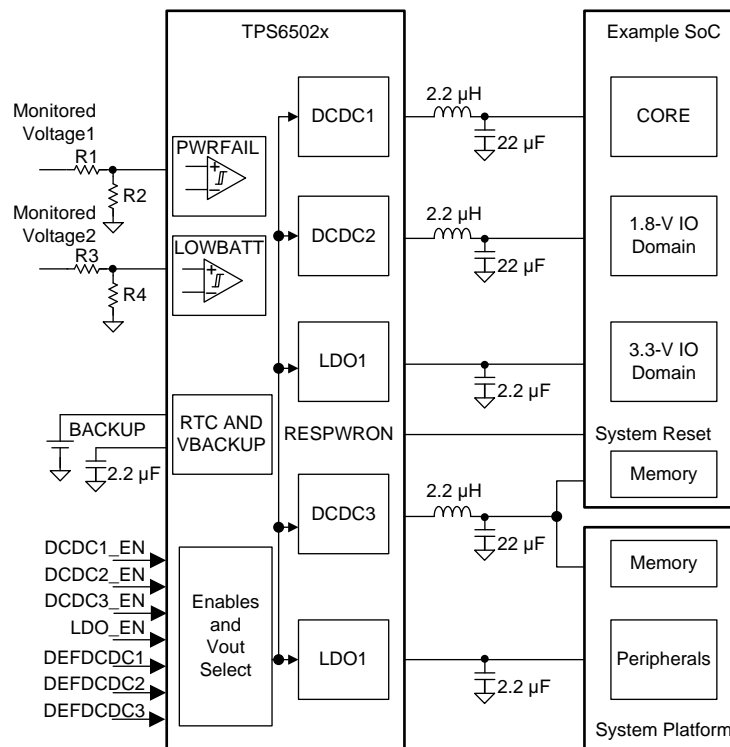
The TPS650231 device is an integrated power management IC for applications powered by one Li-Ion or Li-Polymer cell, and which requires multiple power rails. The TPS650231 provides three highly efficient step-down converters targeted at providing the core voltage, peripheral, I/O, and memory rails in a processor-based system. The core converter allows for on-the-fly voltage changes through serial interface, allowing the system to implement dynamic power savings.

#### Device Information<sup>(1)</sup>

PART NUMBER	PACKAGE	BODY SIZE (NOM)
TPS650231	VQFN (40)	5.00 mm × 5.00 mm
	DSBGA (49)	3.00 mm × 3.00 mm

(1) For all available packages, see the orderable addendum at the end of the data sheet.

#### Simplified Schematic



## Table of Contents

<b>1 Features</b> .....	<b>1</b>	7.13 Typical Characteristics .....	<b>16</b>
<b>2 Applications</b> .....	<b>1</b>	<b>8 Detailed Description</b> .....	<b>21</b>
<b>3 Description</b> .....	<b>1</b>	8.1 Overview .....	<b>21</b>
<b>4 Revision History</b> .....	<b>2</b>	8.2 Functional Block Diagrams .....	<b>22</b>
<b>5 Description (continued)</b> .....	<b>3</b>	8.3 Feature Description .....	<b>23</b>
<b>6 Pin Configuration and Functions</b> .....	<b>3</b>	8.4 Device Functional Modes .....	<b>29</b>
<b>7 Specifications</b> .....	<b>7</b>	8.5 Programming .....	<b>30</b>
7.1 Absolute Maximum Ratings .....	<b>7</b>	8.6 Register Maps .....	<b>32</b>
7.2 ESD Ratings .....	<b>7</b>	<b>9 Application and Implementation</b> .....	<b>38</b>
7.3 Recommended Operating Conditions .....	<b>7</b>	9.1 Application Information .....	<b>38</b>
7.4 Thermal Information .....	<b>8</b>	9.2 Typical Application .....	<b>40</b>
7.5 Electrical Characteristics .....	<b>8</b>	<b>10 Power Supply Recommendations</b> .....	<b>45</b>
7.6 Electrical Characteristics: Control Signals .....	<b>9</b>	10.1 Requirements for Supply Voltages Below 3.0 V ...	<b>45</b>
7.7 Electrical Characteristics: Supply Pins VCC, VINDCDC1, VINDCDC2, VINDCDC3, VINDCDC13 .....	<b>10</b>	<b>11 Layout</b> .....	<b>46</b>
7.8 Electrical Characteristics: Supply Pins VBACKUP, VSYSIN, VRTC, VINLDO .....	<b>10</b>	11.1 Layout Guidelines .....	<b>46</b>
7.9 Electrical Characteristics: VDCDC1 Step-Down Converter .....	<b>11</b>	11.2 Layout Example .....	<b>46</b>
7.10 Electrical Characteristics: VDCDC2 Step-Down Converter .....	<b>11</b>	<b>12 Device and Documentation Support</b> .....	<b>47</b>
7.11 Electrical Characteristics: VDCDC3 Step-Down Converter .....	<b>12</b>	12.1 Device Support .....	<b>47</b>
7.12 Timing Requirements .....	<b>13</b>	12.2 Community Resources .....	<b>47</b>
		12.3 Trademarks .....	<b>47</b>
		12.4 Electrostatic Discharge Caution .....	<b>47</b>
		12.5 Glossary .....	<b>47</b>
		<b>13 Mechanical, Packaging, and Orderable Information</b> .....	<b>47</b>

## 4 Revision History

### Changes from Original (August 2010) to Revision A

Page

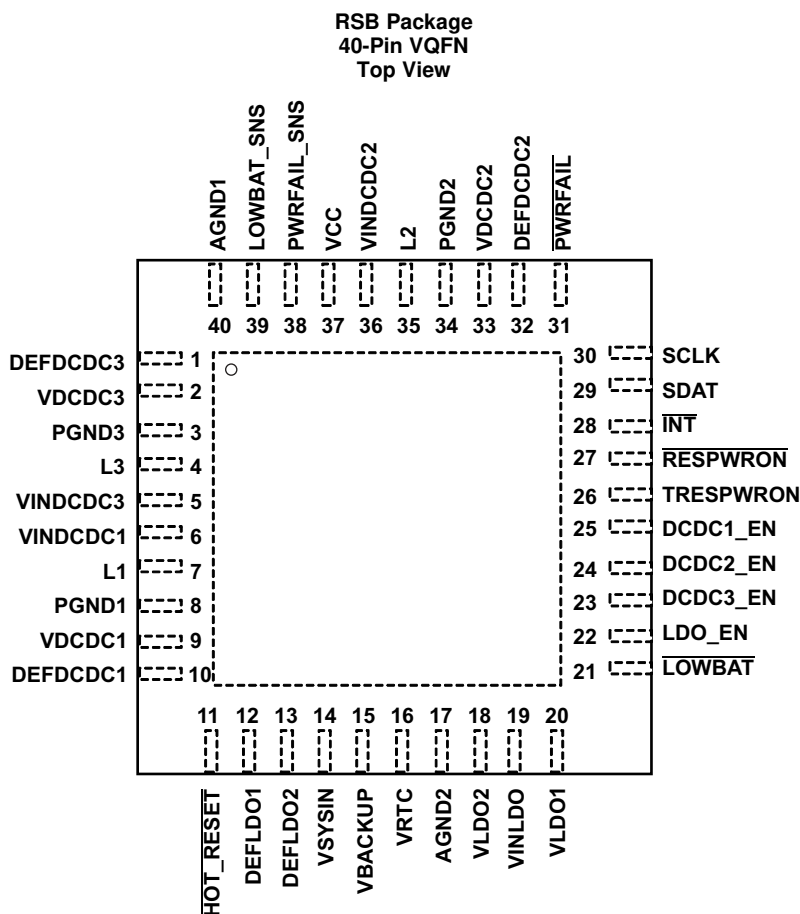
- Added *ESD Ratings* table, *Feature Description* section, *Device Functional Modes*, *Application and Implementation* section, *Power Supply Recommendations* section, *Layout* section, *Device and Documentation Support* section, and *Mechanical, Packaging, and Orderable Information* section .....

1

## 5 Description (continued)

All three step-down converters enter a low-power mode at light load for maximum efficiency across the widest possible range of load currents. The TPS650231 also integrates two general-purpose, 200-mA LDO voltage regulators, which are enabled with an external input pin. Each LDO operates with an input voltage range from 1.5 V to 6.5 V, thus allowing them to be supplied from one of the step-down converters or directly from the battery. The default output voltage of the LDOs can be digitally set to 4 different voltage combinations using the DEFLDO1 and DEFLDO2 pins. The serial interface can be used for dynamic voltage scaling, masking interrupts, or for disabling, enabling, and setting the LDO output voltages. The interface is compatible with the fast and standard mode I<sup>2</sup>C specifications, allowing transfers at up to 400 kHz. The TPS650231 is available in a 40-pin VQFN (RSB) package or in a 49-ball DSBGA (YFF) package, and operates over a free-air temperature of –40°C to +85°C.

## 6 Pin Configuration and Functions

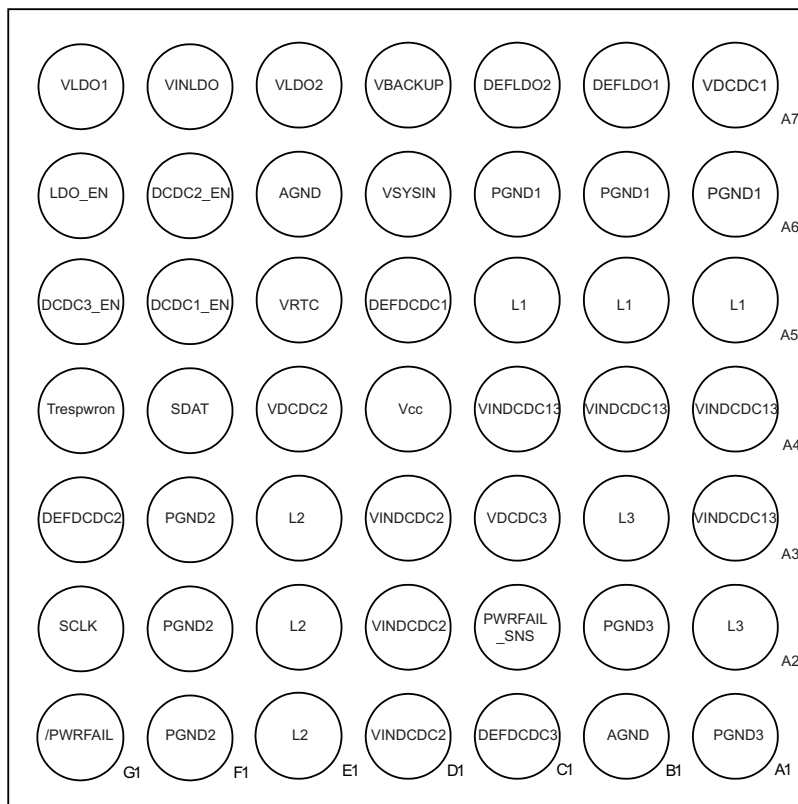


Pin Functions: TPS650231RSB

PIN		I/O	DESCRIPTION
NAME	NO.		
<b>SWITCHING REGULATOR SECTION</b>			
AGND1	40	—	Analog ground. All analog ground pins are connected internally on the chip.
AGND2	17	—	Analog ground. All analog ground pins are connected internally on the chip.
DCDC1_EN	25	I	VDCDC1 enable pin. A logic high enables the regulator, a logic low disables the regulator.
DCDC2_EN	24	I	VDCDC2 enable pin. A logic high enables the regulator, a logic low disables the regulator.
DCDC3_EN	23	I	VDCDC3 enable pin. A logic high enables the regulator, a logic low disables the regulator.

**Pin Functions: TPS650231RSB (continued)**

PIN		I/O	DESCRIPTION
NAME	NO.		
DEFDCDC1	10	I	Input signal indicating default VDCDC1 voltage, 0 = 1.2 V, 1 = 1.6 V; DEFDCDC1 can also be connected to a resistor divider between VDCDC1 and GND, if the output voltage of the DCDC1 converter is set in a range from 0.6 V to VINDCDC1 V.
DEFDCDC2	32	I	Input signal indicating default VDCDC2 voltage, 0 = 1.8 V, 1 = 3.3 V; DEFDCDC2 can also be connected to a resistor divider between VDCDC2 and GND, if the output voltage of the DCDC2 converter is set in a range from 0.6 V to VINDCDC2 V.
DEFDCDC3	1	I	Input signal indicating default VDCDC3 voltage, 0 = 1.8 V, 1 = 3.3 V; DEFDCDC3 can also be connected to a resistor divider between VDCDC3 and GND, if the output voltage of the DCDC3 converter is set in a range from 0.6 V to VINDCDC3 V.
L1	7	—	Switch pin of VDCDC1 converter. The VDCDC1 inductor is connected here.
L2	35	—	Switch pin of VDCDC2 converter. The VDCDC2 inductor is connected here.
L3	4	—	Switch pin of VDCDC3 converter. The VDCDC3 inductor is connected here.
PGND1	8	—	Power ground for VDCDC1 converter
PGND2	34	—	Power ground for VDCDC2 converter
PGND3	3	—	Power ground for VDCDC3 converter
PowerPAD™	—	—	Connect the power pad to analog ground.
VCC	37	I	Power supply for digital and analog circuitry of VDCDC1, VDCDC2, and VDCDC3 DC-DC converters. VCC must be connected to the same voltage supply as VINDCDC3, VINDCDC1, and VINDCDC2. VCC also supplies serial interface block.
VDCDC1	9	I	VDCDC1 feedback voltage sense input. Connect directly to VDCDC1
VDCDC2	33	I	VDCDC2 feedback voltage sense input. Connect directly to VDCDC2
VDCDC3	2	I	VDCDC3 feedback voltage sense input. Connect directly to VDCDC3
VINDCDC1	6	I	Input voltage for VDCDC1 step-down converter. VINDCDC1 must be connected to the same voltage supply as VINDCDC2, VINDCDC3, and VCC.
VINDCDC2	36	I	Input voltage for VDCDC2 step-down converter. VINDCDC2 must be connected to the same voltage supply as VINDCDC1, VINDCDC3, and VCC.
VINDCDC3	5	I	Input voltage for VDCDC3 step-down converter. VINDCDC3 must be connected to the same voltage supply as VINDCDC1, VINDCDC2, and VCC.
<b>LDO REGULATOR SECTION</b>			
DEFLD01	12	I	Digital input. DEFLD01 sets the default output voltage of LDO1 and LDO2.
DEFLD02	13	I	Digital input. DEFLD02 sets the default output voltage of LDO1 and LDO2.
LDO_EN	22	I	Enable input for LDO1 and LDO2. A logic high enables the LDOs, a logic low disables the LDOs.
VBACKUP	15	I	Connect the backup battery to this input pin
VINLDO	19	I	Input voltage for LDO1 and LDO2
VLDO1	20	O	Output voltage of LDO1
VLDO2	18	O	Output voltage of LDO2
VRTC	16	O	Output voltage of the LDO and switch for the real-time clock
VSYSIN	14	I	Input of system voltage for VRTC switch
<b>CONTROL AND I<sup>2</sup>C SECTION</b>			
HOT_RESET	11	I	Push button input that reboots or wakes up the processor through $\overline{\text{RESPWRON}}$ output pin.
$\overline{\text{INT}}$	28	O	Open drain output
$\overline{\text{LOW\_BAT}}$	21	O	Open drain output of LOW_BAT comparator
LOWBAT_SNS	39	I	Input for the comparator driving the $\overline{\text{LOW\_BAT}}$ output
$\overline{\text{PWRFAIL}}$	31	O	Open drain output. Active low when $\overline{\text{PWRFAIL}}$ comparator indicates low VBAT condition.
PWRFAIL_SNS	38	I	Input for the comparator driving the $\overline{\text{PWRFAIL}}$ output
$\overline{\text{RESPWRON}}$	27	O	Open drain system reset output
SCLK	30	I	Serial interface clock line
SDAT	29	I/O	Serial interface data and address
TRESPWRON	26	I	Connect the timing capacitor to TRESPWRON to set the reset delay time: 1 nF → 100 ms

**YFF Package  
49-Pin DSBGA  
Bottom View**

**Pin Functions: TPS650231YFF**

PIN		I/O	DESCRIPTION
NAME	NO.		
<b>SWITCHING REGULATOR SECTION</b>			
AGND	B1, E6		Analog ground. All analog ground pins are connected internally on the chip.
DCDC1_EN	F5	I	VDCDC1 enable pin. A logic high enables the regulator, a logic low disables the regulator.
DCDC2_EN	F6	I	VDCDC2 enable pin. A logic high enables the regulator, a logic low disables the regulator.
DCDC3_EN	G5	I	VDCDC3 enable pin. A logic high enables the regulator, a logic low disables the regulator.
DEFDCDC1	D5	I	Input signal indicating default VDCDC1 voltage, 0 = 1.2 V, 1 = 1.6 V; DEFDCDC1 can also be connected to a resistor divider between VDCDC1 and GND, if the output voltage of the DCDC1 converter is set in a range from 0.6 V to VINDCDC1 V.
DEFDCDC2	G3	I	This pin needs to be connected to a resistor divider between VDCDC2 and GND. The output voltage of the DCDC2 converter is set in a range from 0.6 V to VINDCDC2 V.
DEFDCDC3	C1	I	Input signal indicating default VDCDC3 voltage, 0 = 1.8 V, 1 = 3.3 V; DEFDCDC3 can also be connected to a resistor divider between VDCDC3 and GND, if the output voltage of the DCDC3 converter is set in a range from 0.6 V to VINDCDC3 V.
L1	A5, B5, C5	O	Switch pin of VDCDC1 converter. The VDCDC1 inductor is connected here.
L2	E1, E2, E3	O	Switch pin of VDCDC2 converter. The VDCDC2 inductor is connected here.
L3	A2, B3	O	Switch pin of VDCDC3 converter. The VDCDC3 inductor is connected here.
PGND1	A6, B6, C6		Power ground for VDCDC1 converter
PGND2	F1, F2, F3		Power ground for VDCDC2 converter
PGND3	A1, B2		Power ground for VDCDC3 converter

**Pin Functions: TPS650231YFF (continued)**

PIN		I/O	DESCRIPTION
NAME	NO.		
VCC	D4	I	Power supply for digital and analog circuitry of VDCDC1, VDCDC2, and VDCDC3 DC-DC converters. VCC must be connected to the same voltage supply as VINDCDC13 and VINDCDC2. VCC also supplies the serial interface block.
VDCDC1	A7	I	VDCDC1 feedback voltage sense input. Connect directly to VDCDC1
VDCDC2	E4	I	VDCDC2 feedback voltage sense input. Connect directly to VDCDC2
VDCDC3	C3	I	VDCDC3 feedback voltage sense input. Connect directly to VDCDC3
VINDCDC13	A3, A4, B4, C4	I	Input voltage for VDCDC1 and VDCDC3 step-down converter. This must be connected to the same voltage supply as VINDCDC2 and VCC.
VINDCDC2	D1, D2, D3	I	Input voltage for VDCDC2 step-down converter. VINDCDC2 must be connected to the same voltage supply as VINDCDC13 and VCC.
<b>LDO REGULATOR SECTION</b>			
DEFLD01	B7	I	Digital input. DEFLD01 sets the default output voltage of LDO1 and LDO2.
DEFLD02	C7	I	Digital input. DEFLD02 sets the default output voltage of LDO1 and LDO2.
LDO_EN	G6	I	Enable input for LDO1 and LDO2. A logic high enables the LDOs, a logic low disables the LDOs.
VBACKUP	D7	I	Connect the backup battery to this input pin
VINLDO	F7	I	Input voltage for LDO1 and LDO2
VLDO1	G7	O	Output voltage of LDO1
VLDO2	E7	O	Output voltage of LDO2
VRTC	E5	O	Output voltage of the LDO and switch for the real-time clock
VSYSIN	D6	I	Input of system voltage for VRTC switch
<b>CONTROL AND I<sup>2</sup>C SECTION</b>			
PWRFAIL	G1	O	Open drain output. Active low when $\overline{\text{PWRFAIL}}$ comparator indicates low VBAT condition.
PWRFAIL_SNS	C2	I	Input for the comparator driving the $\overline{\text{PWRFAIL}}$ output
SCLK	G2	I	Serial interface clock line
SDAT	F4	I/O	Serial interface data and address
TRESPWRON	G4	I	Connect a 1-nF capacitor from this pin to GND

## 7 Specifications

### 7.1 Absolute Maximum Ratings

over operating free-air temperature range (unless otherwise noted)<sup>(1)</sup>

		MIN	MAX	UNIT
$V_I$	Input voltage range on all pins except AGND and PGND pins with respect to AGND	-0.3	7	V
	Current at VINDCDC1, L1, PGND1, VINDCDC2, L2, PGND2, VINDCDC3, L3, PGND3		2500	mA
	Peak current at all other pins		1000	mA
$T_A$	Operating free-air temperature	-40	85	°C
$T_J$	Junction temperature		125	°C
$T_{stg}$	Storage temperature	-65	150	°C

- (1) Stresses beyond those listed under *Absolute Maximum Ratings* may cause permanent damage to the device. These are stress ratings only, which do not imply functional operation of the device at these or any other conditions beyond those indicated under *Recommended Operating Conditions*. Exposure to absolute-maximum-rated conditions for extended periods may affect device reliability.

### 7.2 ESD Ratings

		VALUE	UNIT
$V_{(ESD)}$	Electrostatic discharge		
	Human-body model (HBM), per ANSI/ESDA/JEDEC JS-001 <sup>(1)</sup>	±2000	V
Charged-device model (CDM), per JEDEC specification JESD22-C101 <sup>(2)</sup>	±500		

- (1) JEDEC document JEP155 states that 500-V HBM allows safe manufacturing with a standard ESD control process.

- (2) JEDEC document JEP157 states that 250-V CDM allows safe manufacturing with a standard ESD control process.

### 7.3 Recommended Operating Conditions

over operating free-air temperature range (unless otherwise noted)

		MIN	NOM	MAX	UNIT
$V_{CC}$	Input voltage range step-down converters (VINDCDC1, VINDCDC2, VINDCDC3); pins need to be tied to the same voltage rail	2.5		6	V
$V_O$	Output voltage range for VDCDC1 step-down converter <sup>(1)</sup>	0.6		VINDCDC1	V
	Output voltage range for VDCDC2 step-down converter <sup>(1)</sup>	0.6		VINDCDC2	
	Output voltage range for VDCDC3 step-down converter <sup>(1)</sup>	0.6		VINDCDC3	
$V_I$	Input voltage range for LDOs (VINLDO)	1.5		6.5	V
$V_O$	Output voltage range for LDOs (VLDO1, VLDO2)	1		VINLDO1-2	V
$I_{O(DCDC1)}$	Output current at L1			1700	mA
	Inductor at L1 <sup>(2)</sup>	1.5	2.2		
$C_{I(DCDC1)}$	Input capacitor at VINDCDC1 <sup>(2)</sup>	10			µF
$C_{O(DCDC1)}$	Output capacitor at VDCDC1 <sup>(2)</sup>	10	22		µF
$I_{O(DCDC2)}$	Output current at L2			1200	mA
	Inductor at L2 <sup>(2)</sup>	1.5	2.2		
$C_{I(DCDC2)}$	Input capacitor at VINDCDC2 <sup>(2)</sup>	10			µF
$C_{O(DCDC2)}$	Output capacitor at VDCDC2 <sup>(2)</sup>	10	22		µF
$I_{O(DCDC3)}$	Output current at L3			800	mA
	Inductor at L3 <sup>(2)</sup>	1.5	2.2		
$C_{I(DCDC3)}$	Input capacitor at VINDCDC3 <sup>(2)</sup>	10			µF
$C_{O(DCDC3)}$	Output capacitor at VDCDC3 <sup>(2)</sup>	10	22		µF
$C_{I(VCC)}$	Input capacitor at VCC <sup>(2)</sup>	1			µF
$C_{I(VINLDO)}$	Input capacitor at VINLDO <sup>(2)</sup>	1			µF
$C_{O(VLDO1-2)}$	Output capacitor at VLDO1, VLDO2 <sup>(2)</sup>	2.2			µF
$I_{O(VLDO1-2)}$	Output current at VLDO1, VLDO2			200	mA

- (1) When using an external resistor divider at DEFDCDC3, DEFDCDC2, DEFDCDC1

- (2) See [Application Information](#) section for more information

## Recommended Operating Conditions (continued)

over operating free-air temperature range (unless otherwise noted)

		MIN	NOM	MAX	UNIT
$C_{O(VRTC)}$	Output capacitor at VRTC <sup>(2)</sup>	4.7			μF
$T_A$	Operating ambient temperature	-40		85	°C
$T_J$	Operating junction temperature	-40		125	°C
	Resistor from VINDCDC3, VINDCDC2, VINDCDC1 to VCC used for filtering <sup>(3)</sup>		1	10	Ω

(3) Up to 3 mA can flow into  $V_{CC}$  when all 3 converters are running in PWM. This resistor causes the UVLO threshold to be shifted accordingly.

## 7.4 Thermal Information

THERMAL METRIC <sup>(1)</sup>	TPS650231		UNIT	
	RSB (VQFN)	YFF (DSBGA)		
	40 PINS	49 BALLS		
$R_{\theta JA}$	Junction-to-ambient thermal resistance	32.7	40	°C/W
$R_{\theta JC(top)}$	Junction-to-case (top) thermal resistance	15.3	10	°C/W
$R_{\theta JB}$	Junction-to-board thermal resistance	13.6	15	°C/W
$\Psi_{JT}$	Junction-to-top characterization parameter	0.1	0.1	°C/W
$\Psi_{JB}$	Junction-to-board characterization parameter	5.4	14	°C/W
$R_{\theta JC(bot)}$	Junction-to-case (bottom) thermal resistance	1.1	N/A	°C/W

(1) For more information about traditional and new thermal metrics, see the *Semiconductor and IC Package Thermal Metrics* application report (SPRA953).

## 7.5 Electrical Characteristics

VINDCDC1 = VINDCDC2 = VINDCDC3 (VINDCDC13) = VCC = VINLDO = 3.6 V, VBACKUP = 3 V,  $T_A = -40^\circ\text{C}$  to  $+85^\circ\text{C}$  (unless otherwise noted)

PARAMETER	TEST CONDITIONS	MIN	TYP <sup>(1)</sup>	MAX	UNIT
<b>VLDO1 AND VLDO2 LOW-DROPOUT REGULATORS</b>					
$V_I$	Input voltage range for LDO1, 2	1.5		6.5	V
$V_{O(LD01)}$	LDO1 output voltage range	1		3.15	V
$V_{O(LD02)}$	LDO2 output voltage range	1.05		3.3	V
$I_O$	Maximum output current for LDO1, LDO2	$V_I = 1.8\text{ V}, V_O = 1.3\text{ V}$ $V_I = 1.5\text{ V}, V_O = 1.3\text{ V}$	200		mA
$I_{(SC)}$	LDO1 and LDO2 short-circuit current limit	$V_{(LD01)} = \text{GND}, V_{(LD02)} = \text{GND}$		400	mA
	Minimum voltage drop at LDO1, LDO2	$I_O = 50\text{ mA}, \text{VINLDO} = 1.8\text{ V}$ $I_O = 50\text{ mA}, \text{VINLDO} = 1.5\text{ V}$ $I_O = 200\text{ mA}, \text{VINLDO} = 1.8\text{ V}$		65 150 300	mV
	Output voltage accuracy for LDO1, LDO2	$I_O = 10\text{ mA}$	-2%	1%	
	Line regulation for LDO1, LDO2	VINLDO1, 2 = VLDO1,2 + 0.5 V (min. 2.5 V) to 6.5 V, $I_O = 10\text{ mA}$	-1%	1%	
	Load regulation for LDO1, LDO2	$I_O = 0\text{ mA}$ to 50 mA	-1%	1%	
	Regulation time for LDO1, LDO2	Load change from 10% to 90%	10		μs
<b>ANALOGIC SIGNALS DEFDCDC1, DEFDCDC2, DEFDCDC3</b>					
$V_{IH}$	High-level input voltage	1.3		VCC	V
$V_{IL}$	Low-level input voltage	0		0.1	V
	Input bias current		0.001	0.05	μA
<b>THERMAL SHUTDOWN</b>					
$T_{(SD)}$	Thermal shutdown	Increasing junction temperature	160		°C
	Thermal shutdown hysteresis	Decreasing junction temperature	20		°C

(1) Typical values are at  $T_A = 25^\circ\text{C}$



## Electrical Characteristics (continued)

VINDCDC1 = VINDCDC2 = VINDCDC3 (VINDCDC13) = VCC = VINLDO = 3.6 V, VBACKUP = 3 V, T<sub>A</sub> = –40°C to +85°C (unless otherwise noted)

PARAMETER		TEST CONDITIONS	MIN	TYP <sup>(1)</sup>	MAX	UNIT
<b>INTERNAL UNDERVOLTAGE LOCKOUT</b>						
UVLO	Internal UVLO	VCC falling	–2%	2.35	2%	V
V <sub>(UVLO_HYST)</sub>	Internal UVLO comparator hysteresis			120		mV
<b>VOLTAGE DETECTOR COMPARATOR INPUTS PWRFAIL_SNS, LOWBAT_SNS</b>						
	Comparator threshold (PWRFAIL_SNS, LOWBAT_SNS) LOWBAT_SNS for TPS650231RSB only	Falling threshold	–1%	1	1%	V
	Hysteresis		40	50	60	mV
	Propagation delay	25-mV overdrive			10	µs
I <sub>LK</sub>	Input leakage current			0.001	0.1	µA
<b>POWER-GOOD</b>						
V <sub>(PGOODF)</sub>		VDCDC1, VDCDC2, VDCDC3, VLDO1, VLDO2, decreasing	–12%	–10%	–8%	
V <sub>(PGOODR)</sub>		VDCDC1, VDCDC2, VDCDC3, VLDO1, VLDO2, increasing	–7%	–5%	–3%	

## 7.6 Electrical Characteristics: Control Signals

VINDCDC1 = VINDCDC2 = VINDCDC3 = VCC = VINLDO = 3.6 V, VBACKUP = 3 V, T<sub>A</sub> = –40°C to +85°C (unless otherwise noted)

PARAMETER		TEST CONDITIONS	MIN	TYP <sup>(1)</sup>	MAX	UNIT
<b>SCLK, SDAT (INPUT)</b>						
V <sub>IH</sub>	High level input voltage for the SCLK pin	Rpullup at SCLK = 4.7 kΩ, pulled to VRTC; For V <sub>CC</sub> = 2.5 V to 5.25 V	1.4		V <sub>CC</sub>	V
V <sub>IH</sub>	High level input voltage for the SDAT pin	Rpullup at SDAT = 4.7 kΩ, pulled to VRTC; For V <sub>CC</sub> = 2.5 V to 5.25 V	1.69		V <sub>CC</sub>	V
V <sub>IH</sub>	High level input voltage for the SDAT pin	Rpullup at SDAT = 4.7 kΩ, pulled to VRTC; For V <sub>CC</sub> = 2.5 V to 4.5 V	1.55		V <sub>CC</sub>	V
V <sub>IL</sub>	Low level input voltage	Rpullup at SCLK and SDAT = 4.7 kΩ, pulled to VRTC	0		0.35	V
I <sub>H</sub>	Input bias current			0.01	0.1	µA
<b>HOT_RESET, DCDC1_EN, DCDC2_EN, DCDC3_EN, LDO_EN, DEFLDO1, DEFLDO2</b>						
V <sub>IH</sub>	High-level input voltage		1.3		V <sub>CC</sub>	V
V <sub>IL</sub>	Low-level input voltage		0		0.4	V
I <sub>IB</sub>	Input bias current			0.01	0.1	µA
t <sub>deglitch</sub>	Deglitch time at HOT_RESET		25	30	35	ms
<b>LOWBAT, PWRFAIL, RESPWRON, INT, SDAT (OUTPUT)</b>						
V <sub>OH</sub>	High-level output voltage				6	V
V <sub>OL</sub>	Low-level output voltage	I <sub>IL</sub> = 5 mA	0		0.3	V
	Duration of low pulse at $\overline{\text{RESPWRON}}$	External capacitor 1 nF		100		ms
ICONST	Internal charge or discharge current on pin TRESPWRON	Used for generating $\overline{\text{RESPWRON}}$ delay	1.7	2	2.3	µA
TRESPWRON_LOWTH	Internal lower comparator threshold on pin TRESPWRON	Used for generating $\overline{\text{RESPWRON}}$ delay	0.225	0.25	0.275	V
TRESPWRON_UPTH	Internal upper comparator threshold on pin TRESPWRON	Used for generating $\overline{\text{RESPWRON}}$ delay	0.97	1	1.103	V
	Resetpwrn threshold	VRTC falling	–3%	2.4	3%	V
	Resetpwrn threshold	VRTC rising	–3%	2.52	3%	V
I <sub>LK</sub>	Leakage current	Output inactive high		0.001	0.1	µA

(1) Typical values are at T<sub>A</sub> = 25°C

## 7.7 Electrical Characteristics: Supply Pins VCC, VINDCDC1, VINDCDC2, VINDCDC3, VINDCDC13

VINDCDC1 = VINDCDC2 = VINDCDC3 = VCC = VINLDO = 3.6 V, VBACKUP = 3 V, T<sub>A</sub> = –40°C to +85°C (unless otherwise noted)

PARAMETER		TEST CONDITIONS	MIN	TYP <sup>(1)</sup>	MAX	UNIT
I <sub>(q)</sub>	Operating quiescent current, PFM	All 3 DCDC converters enabled, zero load, and no switching, LDOs enabled; VCC = 3.6 V, VBACKUP = 3 V; V <sub>(V<sub>VSYSIN</sub>)</sub> = 0 V		85	100	μA
		All 3 DCDC converters enabled, zero load, and no switching, LDOs off; VCC = 3.6 V, VBACKUP = 3 V; V <sub>(V<sub>VSYSIN</sub>)</sub> = 0 V		78	90	
		DCDC1 and DCDC2 converters enabled, zero load, and no switching, LDOs off; VCC = 3.6 V, VBACKUP = 3 V; V <sub>(V<sub>VSYSIN</sub>)</sub> = 0 V		57	70	
		DCDC1 converter enabled, zero load, and no switching, LDOs off; VCC = 3.6 V, VBACKUP = 3 V; V <sub>(V<sub>VSYSIN</sub>)</sub> = 0 V		43	55	
I <sub>I</sub>	Current into VCC; PWM	All 3 DCDC converters enabled and running in PWM, LDOs off; VCC = 3.6 V, VBACKUP = 3 V; V <sub>(V<sub>VSYSIN</sub>)</sub> = 0 V		2	3	mA
		DCDC1 and DCDC2 converters enabled and running in PWM, LDOs off; VCC = 3.6 V, VBACKUP = 3 V; V <sub>(V<sub>VSYSIN</sub>)</sub> = 0 V		1.5	2.5	
		DCDC1 converter enabled and running in PWM, LDOs off; VCC = 3.6 V, VBACKUP = 3 V; V <sub>(V<sub>VSYSIN</sub>)</sub> = 0 V		0.85	2	
I <sub>(q)</sub>	Quiescent current	All converters disabled, LDOs off; VCC = 3.6 V, VBACKUP = 3 V; V <sub>(V<sub>VSYSIN</sub>)</sub> = 0 V		23	33	μA
		All converters disabled, LDOs off; VCC = 2.6 V, VBACKUP = 3 V; V <sub>(V<sub>VSYSIN</sub>)</sub> = 0 V		3.5	5	μA
		All converters disabled, LDOs off; VCC = 3.6 V, VBACKUP = 0 V; V <sub>(V<sub>VSYSIN</sub>)</sub> = 0 V				43
I <sub>(SD)</sub>	Shutdown supply current into VINDCDC1 for TPS650231RSB	DCDC1_EN = GND		0.1	1	μA
	Shutdown supply current into VINDCDC2 for TPS650231RSB	DCDC2_EN = GND		0.1	1	μA
	Shutdown supply current into VINDCDC3 for TPS650231RSB	DCDC3_EN = GND		0.1	1	μA
	Shutdown supply current into VINDCDC13 for TPS650231YFF	DCDC1_EN = DCDC3_EN = GND		0.2	2	μA

(1) Typical values are at T<sub>A</sub> = 25°C

## 7.8 Electrical Characteristics: Supply Pins VBACKUP, VSYSIN, VRTC, VINLDO

VINDCDC1 = VINDCDC2 = VINDCDC3 (VINDCDC13) = VCC = VINLDO = 3.6 V, VBACKUP = 3 V, T<sub>A</sub> = –40°C to +85°C (unless otherwise noted)

PARAMETER		TEST CONDITIONS	MIN	TYP <sup>(1)</sup>	MAX	UNIT
<b>VBACKUP, VSYSIN, VRTC</b>						
I <sub>(q)</sub>	Operating quiescent current	VBACKUP = 3 V, VSYSIN = 0 V; VCC = 2.6 V, current into VBACKUP		20	33	μA
I <sub>(SD)</sub>	Operating quiescent current	VBACKUP < V <sub>VBACKUP</sub> , current into VBACKUP		2	3	μA
	VRTC LDO output voltage	VSYSIN = VBACKUP = 0 V, I <sub>O</sub> = 0 mA		3		V
I <sub>O</sub>	Output current for VRTC	VSYSIN < 2.57 V and VBACKUP < 2.57 V			30	mA
	VRTC short-circuit current limit	VRTC = GND; VSYSIN = VBACKUP = 0 V			100	mA
	Maximum output current at VRTC for RESPWRON = 1	VRTC > 2.6 V, V <sub>CC</sub> = 3 V; VSYSIN = VBACKUP = 0 V		30		mA
V <sub>O</sub>	Output voltage accuracy for VRTC	VSYSIN = VBACKUP = 0 V; I <sub>O</sub> = 0 mA		–1%	1%	
	Line regulation for VRTC	VCC = VRTC + 0.5 V to 6.5 V, I <sub>O</sub> = 5 mA		–1%	1%	
	Load regulation VRTC	I <sub>O</sub> = 1 mA to 30 mA; VSYSIN = VBACKUP = 0 V		–3%	1%	
	Regulation time for VRTC	Load change from 10% to 90%		10		μs
I <sub>lkg</sub>	Input leakage current at VSYSIN	VSYSIN < V <sub>VSYSIN</sub>			2	μA
	r <sub>DS(on)</sub> of VSYSIN switch				12.5	Ω
	r <sub>DS(on)</sub> of VBACKUP switch				12.5	Ω
	Input voltage range at VBACKUP		2.73		3.75	V
	Input voltage range at VSYSIN		2.73		3.75	V

(1) Typical values are at T<sub>A</sub> = 25°C

## Electrical Characteristics: Supply Pins VBACKUP, VSYSIN, VRTC, VINLDO (continued)

VINDCDC1 = VINDCDC2 = VINDCDC3 (VINDCDC13) = VCC = VINLDO = 3.6 V, VBACKUP = 3 V, T<sub>A</sub> = –40°C to +85°C (unless otherwise noted)

PARAMETER	TEST CONDITIONS	MIN	TYP <sup>(1)</sup>	MAX	UNIT	
VSYSIN threshold	VSYSIN falling	–3%	2.55	3%	V	
VSYSIN threshold	VSYSIN rising	–3%	2.65	3%	V	
VBACKUP threshold	VBACKUP falling	–3%	2.55	3%	V	
VBACKUP threshold	VBACKUP falling	–3%	2.65	3%	V	
<b>VINLDO</b>						
I <sub>(q)</sub>	Operating quiescent current	Current per LDO into VINLDO		20	33	μA
I <sub>(SD)</sub>	Shutdown current	Total current for both LDOs into VINLDO, VLDO = 0 V		0.1	1	μA

## 7.9 Electrical Characteristics: VDCDC1 Step-Down Converter

VINDCDC1 = VINDCDC2 = VINDCDC3 = VCC = VINLDO = 3.6 V, VBACKUP = 3 V, T<sub>A</sub> = –40°C to +85°C (unless otherwise noted)

PARAMETER	TEST CONDITIONS	MIN	TYP <sup>(1)</sup>	MAX	UNIT		
V <sub>I</sub>	Input voltage range, VINDCDC1	2.5		6	V		
I <sub>O</sub>	Maximum output current	1700			mA		
r <sub>DS(on)</sub>	P-channel MOSFET ON-resistance	VINDCDC1 (VINDCDC13) = V <sub>(GS)</sub> = 3.6 V		125	261	mΩ	
I <sub>ikg</sub>	P-channel leakage current	VINDCDC1 (VINDCDC13) = 6 V		2	μA		
r <sub>DS(on)</sub>	N-channel MOSFET ON-resistance	VINDCDC1 (VINDCDC13) = V <sub>(GS)</sub> = 3.6 V		130	260	mΩ	
I <sub>ikg</sub>	N-channel leakage current	V <sub>(DS)</sub> = 6 V		7	10	μA	
	Forward current limit (P-channel and N-channel)	2.5 V < V <sub>(VINDCDC1)</sub> < 6 V		1.94	2.19	2.44	A
f <sub>S</sub>	Oscillator frequency	1.95	2.25	2.55	MHz		
	Fixed output voltage FPWMDCDC1 = 0; all VDCDC1	VINDCDC1 (VINDCDC13) = 2.5 V to 6 V; 0 mA ≤ I <sub>O</sub> ≤ 1.7 A		–2%	2%		
	Fixed output voltage FPWMDCDC1 = 1; all VDCDC1	VINDCDC1 (VINDCDC13) = 2.5 V to 6 V; 0 mA ≤ I <sub>O</sub> ≤ 1.7 A		–1%	1%		
	Adjustable output voltage with resistor divider at DEFDCDC1; FPWMDCDC1 = 0	VINDCDC1 (VINDCDC13) = VDCDC1 + 0.5 V (min 2.5 V) to 6 V; 0 mA ≤ I <sub>O</sub> ≤ 1.7 A		–2%	2%		
	Adjustable output voltage with resistor divider at DEFDCDC1; FPWMDCDC1 = 1	VINDCDC1 (VINDCDC13) = VDCDC1 + 0.5 V (min 2.5 V) to 6 V; 0 mA ≤ I <sub>O</sub> ≤ 1.7 A		–1%	1%		
	Line regulation	VINDCDC1 (VINDCDC13) = VDCDC1 + 0.3 V (min 2.5 V) to 6 V; I <sub>O</sub> = 10 mA		0%		V	
	Load regulation	I <sub>O</sub> = 10 mA to 1700 mA		0.25%		A	
t <sub>Start</sub>	Start-up time	Time from active EN to start switching		145	175	200	μs
t <sub>Ramp</sub>	V <sub>OUT</sub> ramp-up time	Time to ramp from 5% to 95% of V <sub>OUT</sub>		400	750	1000	μs
	Internal resistance from L1 to GND			1		MΩ	
	VDCDC1 discharge resistance	DCDC1 discharge = 1		300		Ω	

(1) Typical values are at T<sub>A</sub> = 25°C

## 7.10 Electrical Characteristics: VDCDC2 Step-Down Converter

VINDCDC1 = VINDCDC2 = VINDCDC3 (VINDCDC13) = VCC = VINLDO = 3.6 V, VBACKUP = 3 V, T<sub>A</sub> = –40°C to +85°C (unless otherwise noted)

PARAMETER	TEST CONDITIONS	MIN	TYP <sup>(1)</sup>	MAX	UNIT	
V <sub>I</sub>	Input voltage range, VINDCDC2	2.5		6	V	
I <sub>O</sub>	Maximum output current	VDCDC2 = 1.2V		1200	mA	
		VINDCDC2 = 3.7 V; 3.3 V – 1% ≤ VDCDC2 ≤ 3.3 V + 1%		1000		
r <sub>DS(on)</sub>	P-channel MOSFET ON-resistance	VINDCDC2 = V <sub>(GS)</sub> = 3.6 V		140	300	mΩ
I <sub>ikg</sub>	P-channel leakage current	VINDCDC2 = 6 V		2	μA	
r <sub>DS(on)</sub>	N-channel MOSFET ON-resistance	VINDCDC2 = V <sub>(GS)</sub> = 3.6 V		150	297	mΩ

(1) Typical values are at T<sub>A</sub> = 25°C

## Electrical Characteristics: VDCDC2 Step-Down Converter (continued)

VINDCDC1 = VINDCDC2 = VINDCDC3 (VINDCDC13) = VCC = VINLDO = 3.6 V, VBACKUP = 3 V, T<sub>A</sub> = –40°C to +85°C (unless otherwise noted)

PARAMETER	TEST CONDITIONS	MIN	TYP <sup>(1)</sup>	MAX	UNIT
I <sub>lkg</sub>	N-channel leakage current V <sub>(DS)</sub> = 6 V		7	10	μA
I <sub>LIMF</sub>	Forward current limit (P-channel and N-channel) 2.5 V < VINDCDC2 < 6 V	1.74	1.94	2.12	A
f <sub>S</sub>	Oscillator frequency	1.95	2.25	2.55	MHz
VDCDC2	Adjustable output voltage with resistor divider at DEFDCDC2; FPWMDCDC2 = 0 VINDCDC2 = VDCDC2 + 0.4 V (min 2.5 V) to 6 V; 0 mA ≤ I <sub>O</sub> ≤ 1.2 A	–2%		2%	
VDCDC2	Adjustable output voltage with resistor divider at DEFDCDC2; FPWMDCDC2 = 1 VINDCDC2 = VDCDC2 + 0.4 V (min 2.5 V) to 6 V; 0 mA ≤ I <sub>O</sub> ≤ 1.2 A	–1%		1%	
	Line regulation VINDCDC2 = VDCDC2 + 0.3 V (min. 2.5 V) to 6 V; I <sub>O</sub> = 10 mA		0%		V
	Load regulation I <sub>O</sub> = 10 mA to 1.2 A		0.25%		A
t <sub>Start</sub>	Start-up time Time from active EN to start switching	145	175	200	μs
t <sub>Ramp</sub>	V <sub>OUT</sub> ramp-up time Time to ramp from 5% to 95% of V <sub>OUT</sub>	400	750	1000	μs
	Internal resistance from L2 to GND		1		MΩ
	VDCDC2 discharge resistance DCDC2 discharge = 1		300		Ω

## 7.11 Electrical Characteristics: VDCDC3 Step-Down Converter

VINDCDC1 = VINDCDC2 = VINDCDC3 (VINDCDC13) = VCC = VINLDO = 3.6 V, VBACKUP = 3 V, T<sub>A</sub> = –40°C to +85°C (unless otherwise noted)

PARAMETER	TEST CONDITIONS	MIN	TYP <sup>(1)</sup>	MAX	UNIT
V <sub>I</sub>	Input voltage range, VINDCDC3	2.5		6	V
I <sub>O</sub>	Maximum output current DEFDCDC3 = GND VINDCDC3 (VINDCDC13) = 3.6 V; 3.3 V – 1% ≤ VDCDC3 ≤ 3.3 V + 1%	800			mA
		525			
r <sub>DS(on)</sub>	P-channel MOSFET ON-resistance VINDCDC3 (VINDCDC13) = V <sub>(GS)</sub> = 3.6 V		310	698	mΩ
I <sub>lkg</sub>	P-channel leakage current VINDCDC3 (VINDCDC13) = 6 V		0.1	2	μA
r <sub>DS(on)</sub>	N-channel MOSFET ON-resistance VINDCDC3 (VINDCDC13) = V <sub>(GS)</sub> = 3.6 V		220	503	mΩ
I <sub>lkg</sub>	N-channel leakage current V <sub>(DS)</sub> = 6 V		7	10	μA
	Forward current limit (P-channel and N-channel) 2.5 V < VINDCDC3 (VINDCDC13) < 6 V	1.28	1.49	1.69	A
f <sub>S</sub>	Oscillator frequency	1.95	2.25	2.55	MHz
	Fixed output voltage FPWMDCDC3 = 0 VDCDC3 = 1.8 V; VINDCDC3 (VINDCDC13) = 2.5 V to 6 V; 0 mA ≤ I <sub>O</sub> ≤ 0.8 A	–2%		2%	
	VDCDC3 = 3.3 V; VINDCDC3 (VINDCDC13) = 3.6 V to 6 V; 0 mA ≤ I <sub>O</sub> ≤ 0.8 A	–1%		1%	
	Fixed output voltage FPWMDCDC3 = 1 VDCDC3 = 1.8 V; VINDCDC3 (VINDCDC13) = 2.5 V to 6 V; 0 mA ≤ I <sub>O</sub> ≤ 0.8 A	–2%		2%	
	VDCDC3 = 3.3 V; VINDCDC3 (VINDCDC13) = 3.6 V to 6 V; 0 mA ≤ I <sub>O</sub> ≤ 0.8 A	–1%		1%	
	Adjustable output voltage with resistor divider at DEFDCDC3 FPWMDCDC3 = 0 VINDCDC3 (VINDCDC13) = VDCDC3 + 0.5 V (min 2.5 V) to 6 V; 0 mA ≤ I <sub>O</sub> ≤ 800 mA	–2%		2%	
	Adjustable output voltage with resistor divider at DEFDCDC3; FPWMDCDC3 = 1 VINDCDC3 (VINDCDC13) = VDCDC3 + 0.5 V (min 2.5 V) to 6 V; 0 mA ≤ I <sub>O</sub> ≤ 800 mA	–1%		1%	
	Line regulation VINDCDC3 (VINDCDC13) = VDCDC3 + 0.3 V (min 2.5 V) to 6 V; I <sub>O</sub> = 10 mA		0%		V
	Load regulation I <sub>O</sub> = 10 mA to 800 mA		0.25%		A
t <sub>Start</sub>	Start-up time Time from active EN to start switching	145	175	200	μs
t <sub>Ramp</sub>	V <sub>OUT</sub> ramp-up time Time to ramp from 5% to 95% of V <sub>OUT</sub>	400	750	1000	μs
	Internal resistance from L3 to GND		1		MΩ
	VDCDC3 discharge resistance DCDC3 discharge = 1		300		Ω

(1) Typical values are at T<sub>A</sub> = 25°C

### 7.12 Timing Requirements

Operating conditions: VINDCDC1 = VINDCDC2 = VINDCDC3 = VCC = VINLDO = 2.5 V to 5.5 V, VBACKUP = 3.0 V, T<sub>A</sub> = -40°C to +85°C

		MIN	MAX	UNIT
f <sub>MAX</sub>	Clock frequency		400	kHz
t <sub>WH(HIGH)</sub>	Clock high time	600		ns
t <sub>WL(LOW)</sub>	Clock low time	1300		ns
t <sub>R</sub>	DATA and CLK rise time		300	ns
t <sub>F</sub>	DATA and CLK fall time		300	ns
t <sub>h(STA)</sub>	Hold time (repeated) START condition (after this period the first clock pulse is generated)	600		ns
t <sub>su(DATA)</sub>	Setup time for repeated START condition	600		ns
t <sub>h(DATA)</sub>	Data input hold time	100		ns
t <sub>su(DATA)</sub>	Data input setup time	100		ns
t <sub>su(STO)</sub>	STOP condition setup time	600		ns
t <sub>(BUF)</sub>	Bus free time	1300		ns

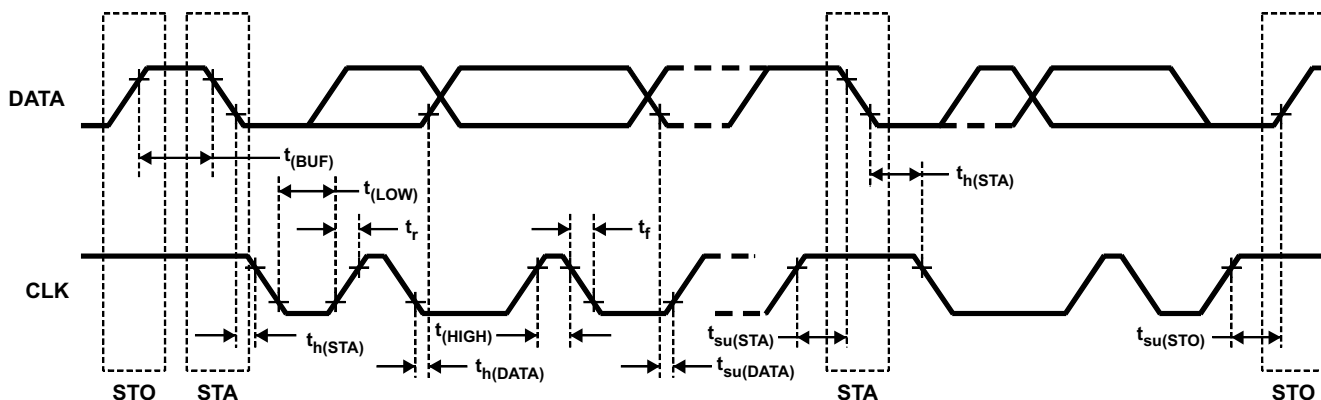


Figure 1. Serial I/F Timing Diagram

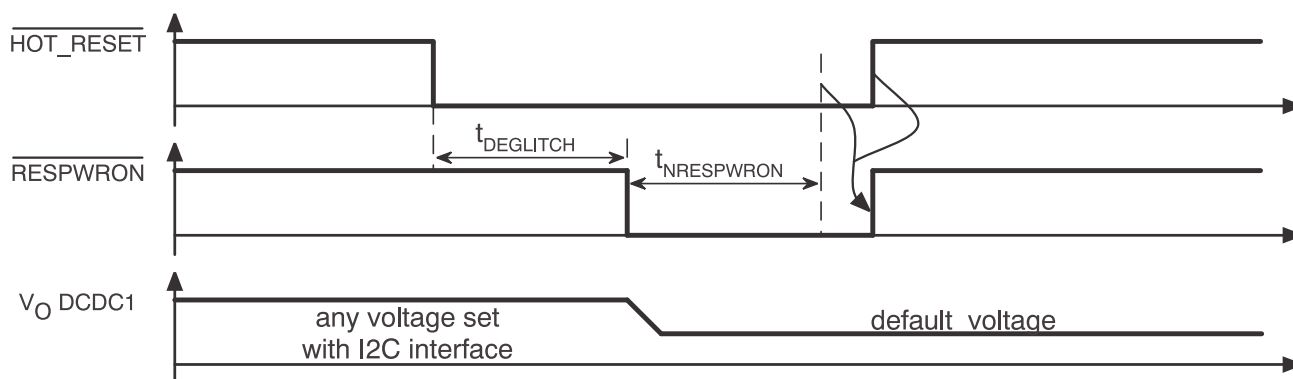


Figure 2. HOT\_RESET Timing (TPS650231RSB Only)

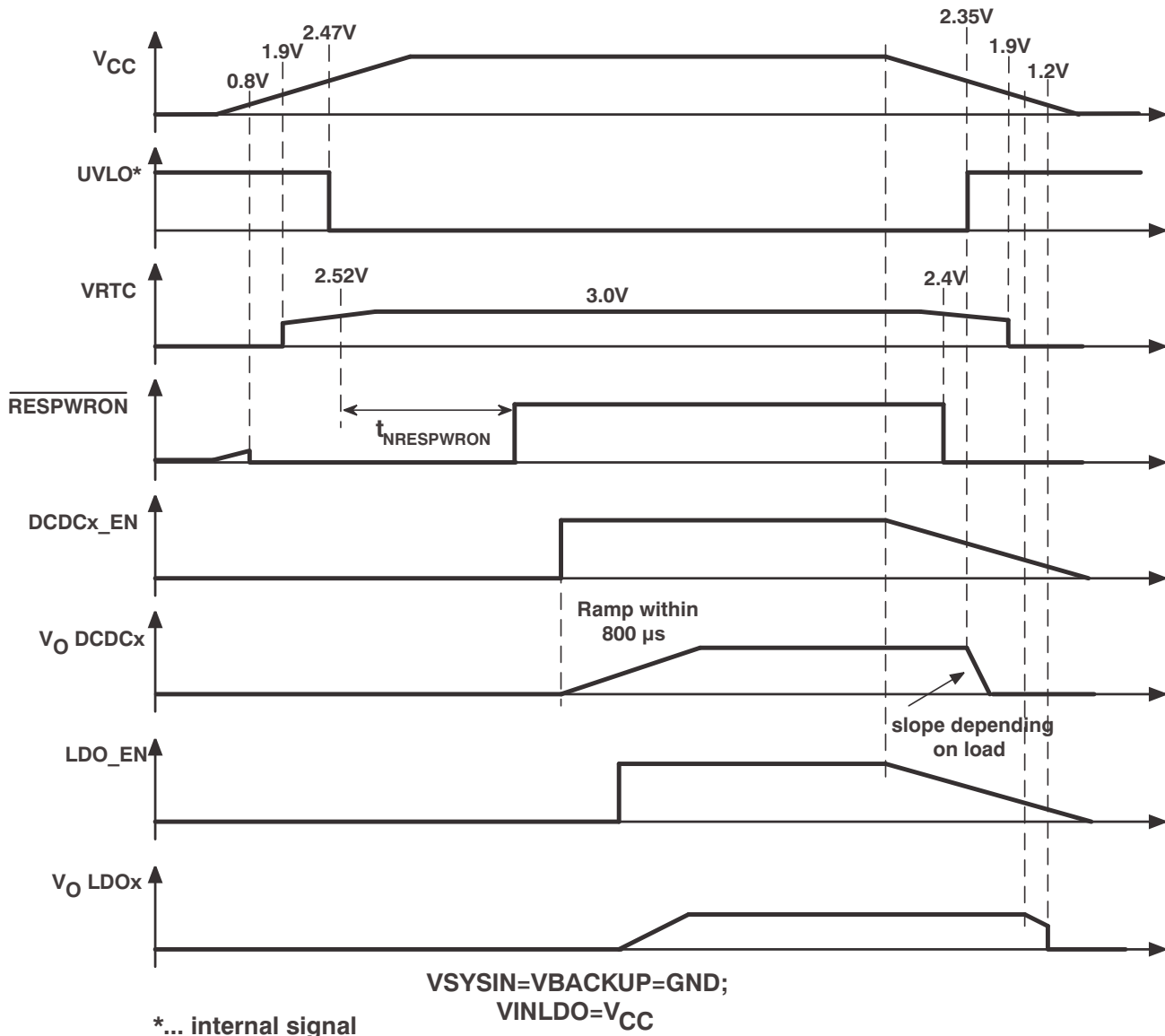


Figure 3. Power-Up and Power-Down Timing

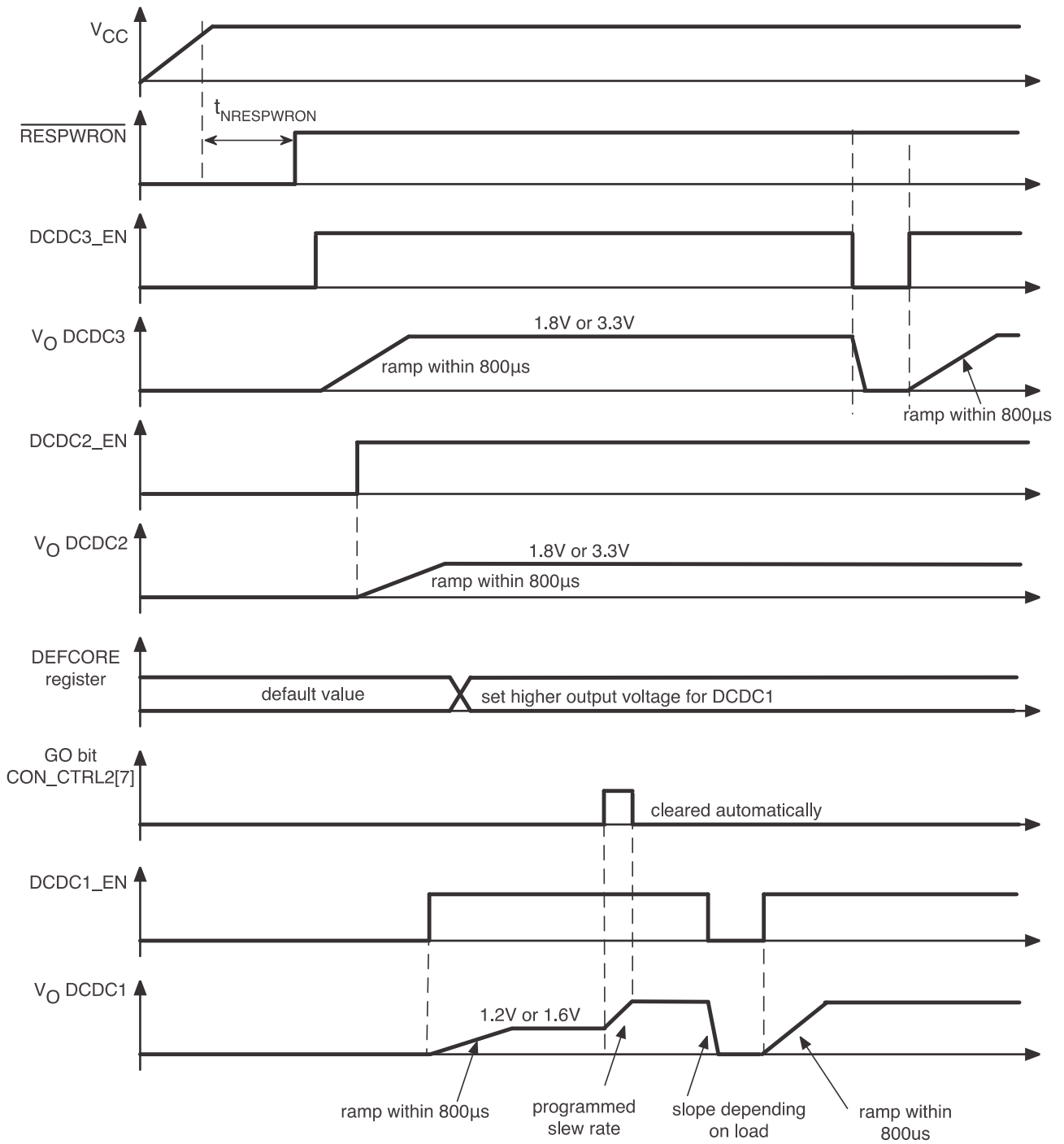
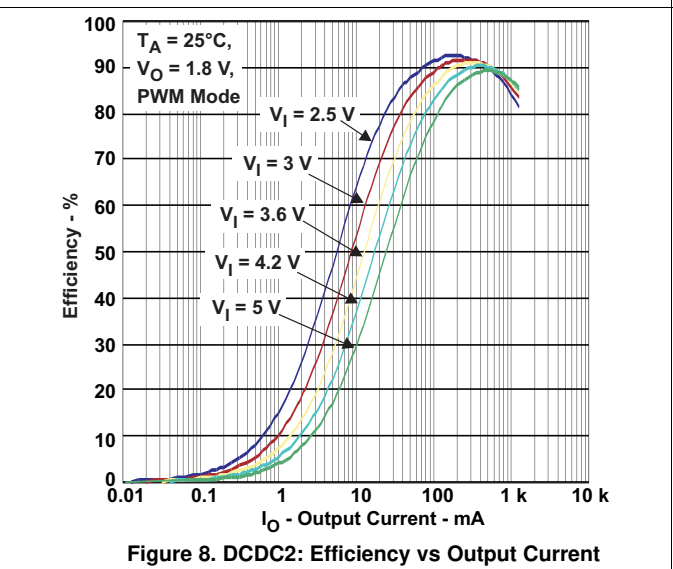
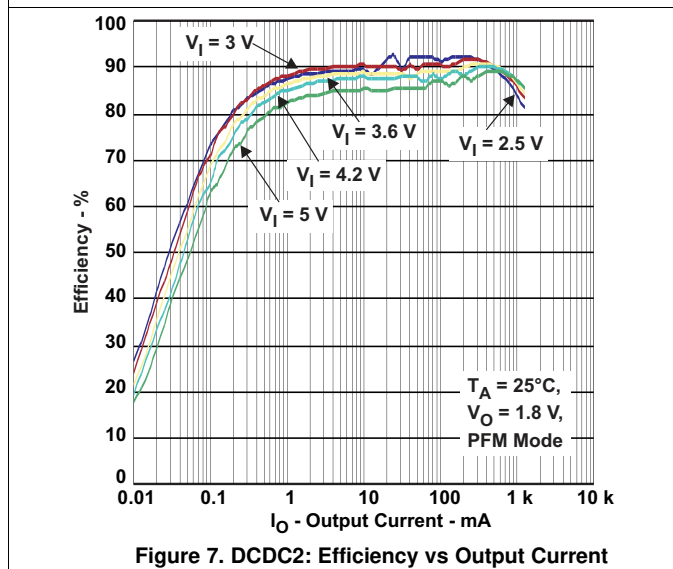
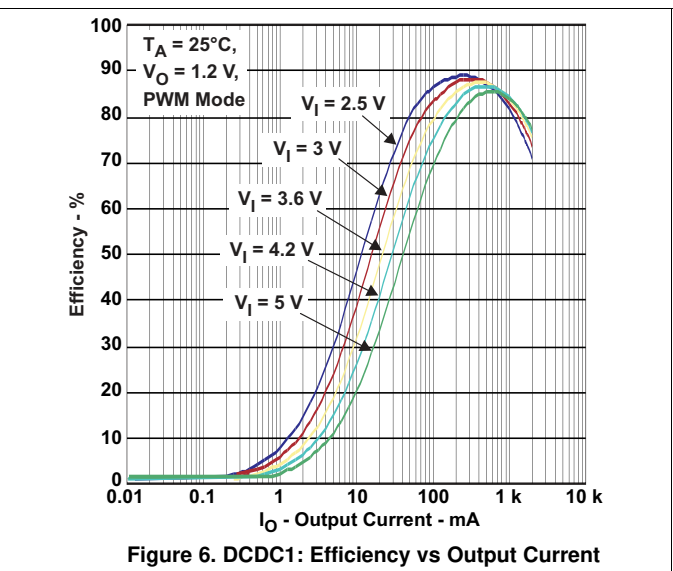
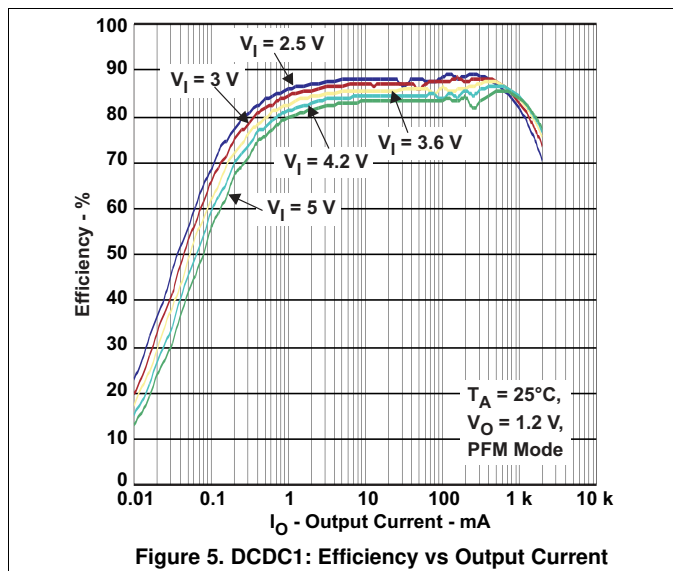


Figure 4. DVS Timing

### 7.13 Typical Characteristics

Table 1. Table of Graphs

		FIGURE
$\eta$ Efficiency	vs Output current	Figure 5, Figure 6, Figure 7, Figure 8, Figure 9, Figure 10
Output voltage	vs Output current at 85°C	Figure 11, Figure 12
Line transient response		Figure 13, Figure 14, Figure 15
Load transient response		Figure 16, Figure 17, Figure 18
VDCDC2 PFM operation		Figure 19
VDCDC2 low-ripple PFM operation		Figure 20
VDCDC2 PWM operation		Figure 21
Start-up VDCDC1, VDCDC2 and VDCDC3		Figure 22
Start-up LDO1 and LDO2		Figure 23
Line transient response		Figure 24, Figure 25, Figure 26
Load transient response		Figure 27, Figure 28, Figure 29





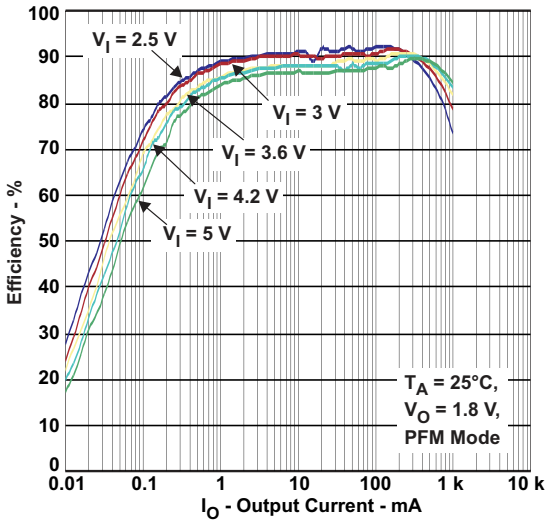


Figure 9. DCDC3: Efficiency vs Output Current

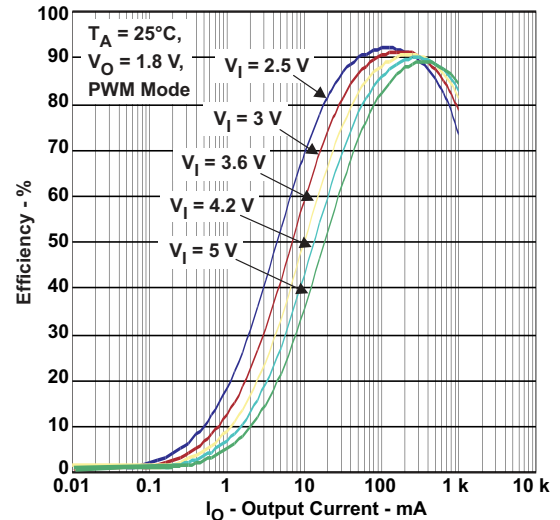


Figure 10. DCDC3: Efficiency vs Output Current

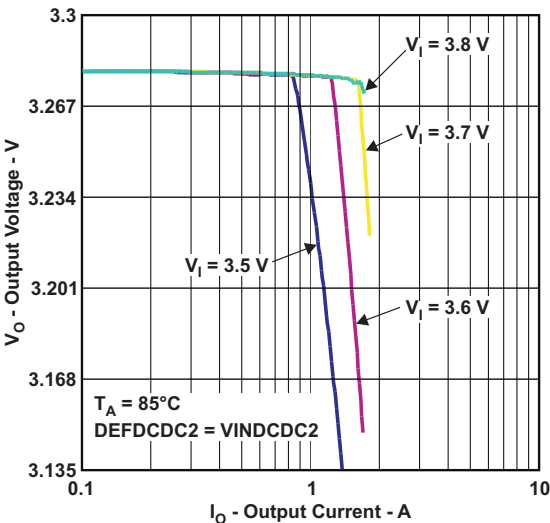


Figure 11. DCDC2: Output Voltage vs Output Current at 85°C

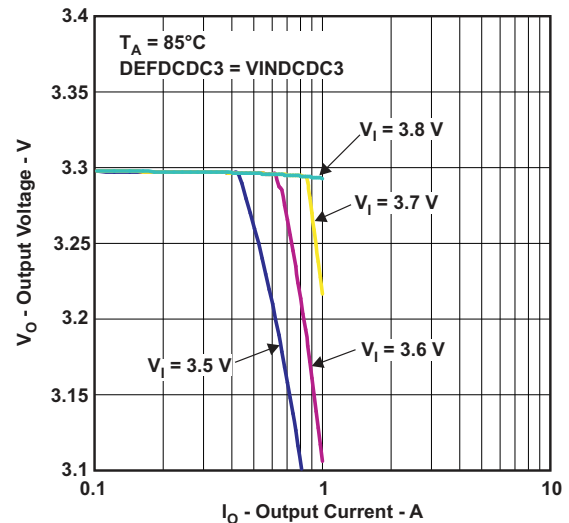


Figure 12. DCDC3: Output Voltage vs Output Current at 85°C

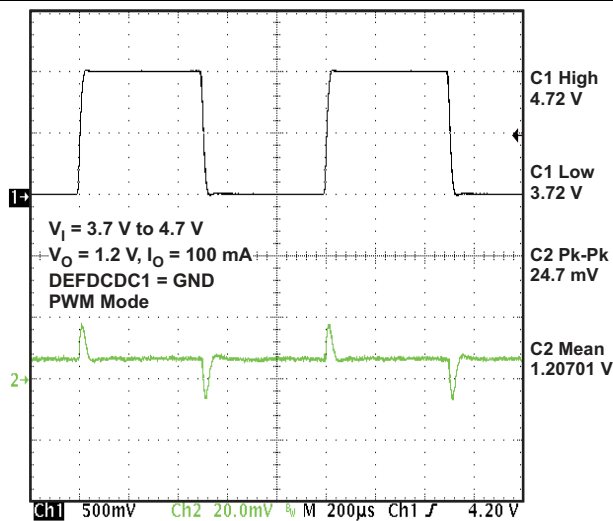


Figure 13. VDCDC1 Line Transient Response

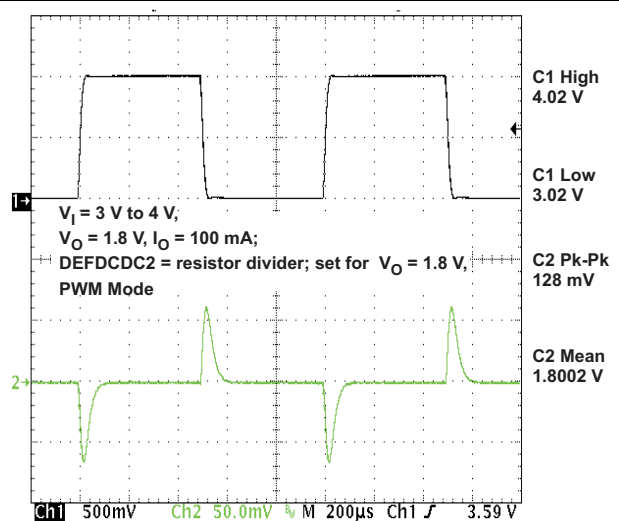
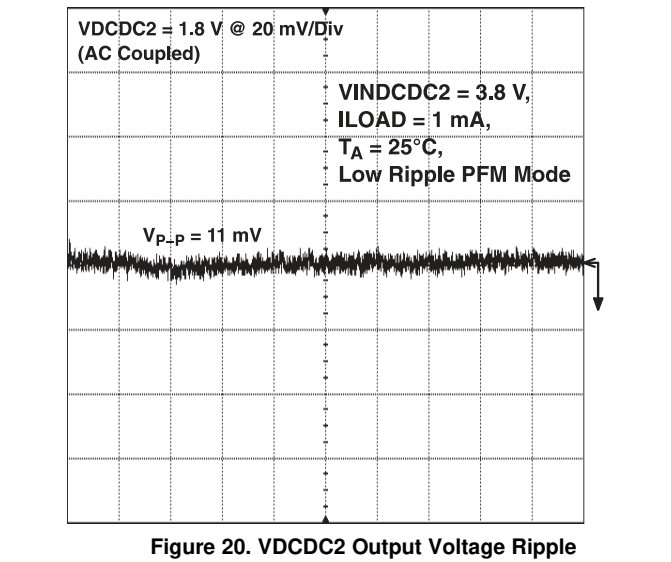
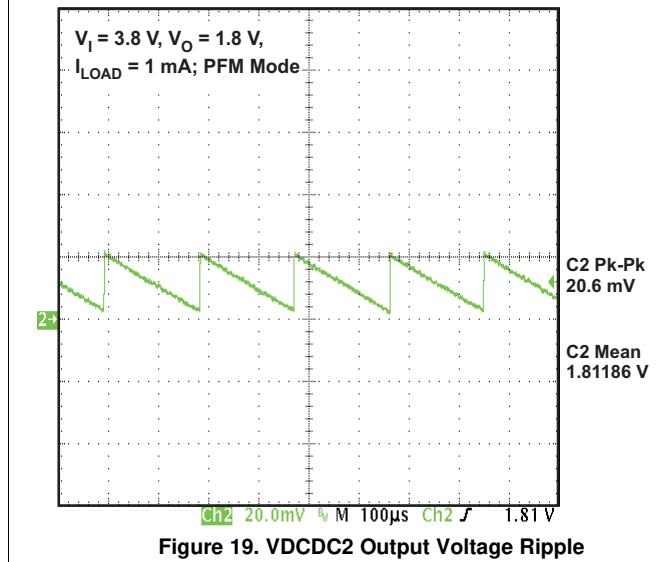
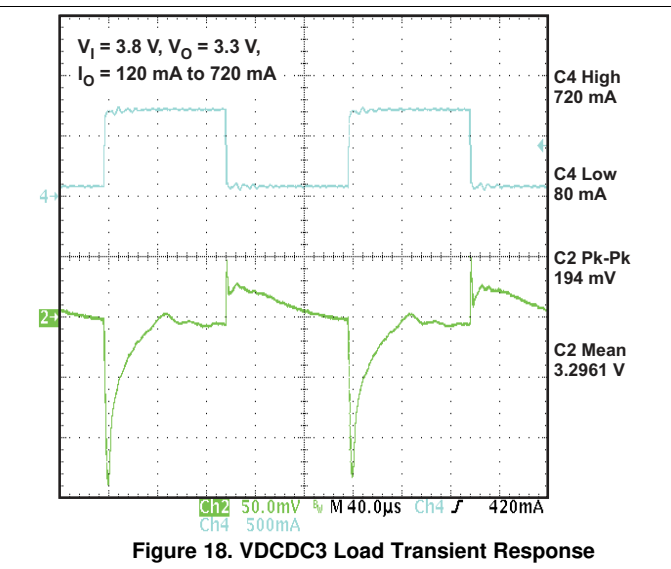
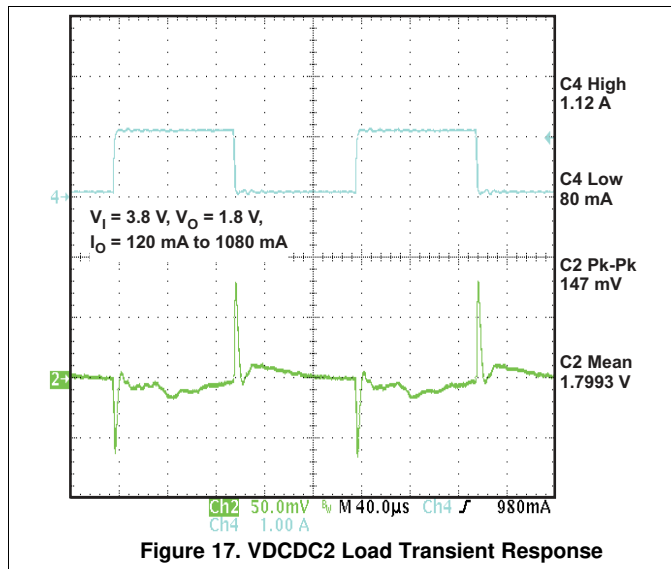
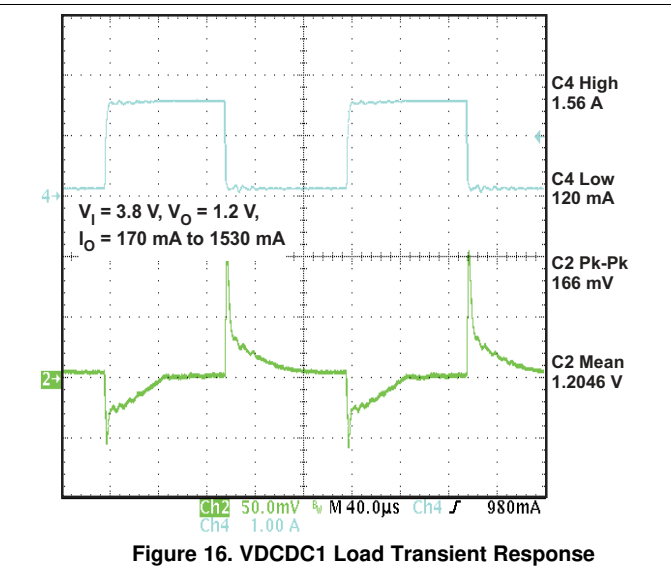
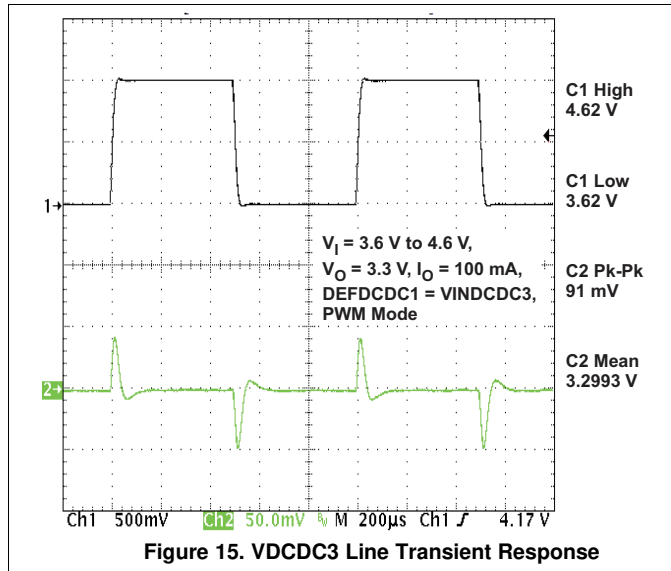


Figure 14. VDCDC2 Line Transient Response



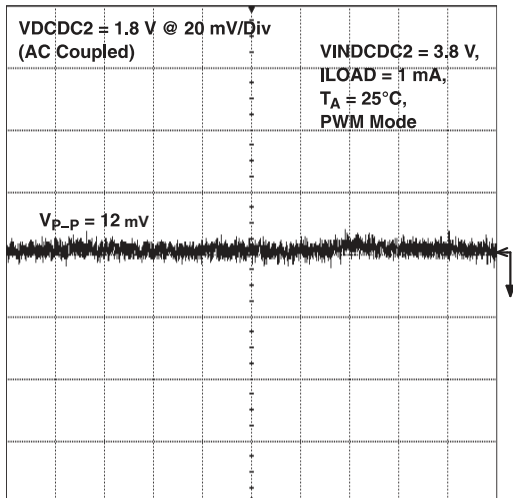


Figure 21. VDCDC2 Output Voltage Ripple

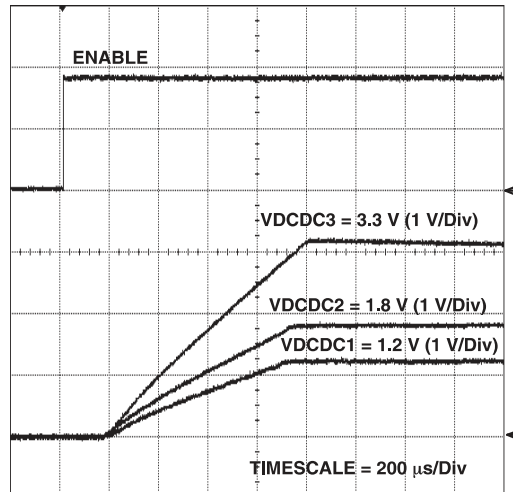


Figure 22. Start-Up VDCDC1, VDCDC2, and VDCDC3

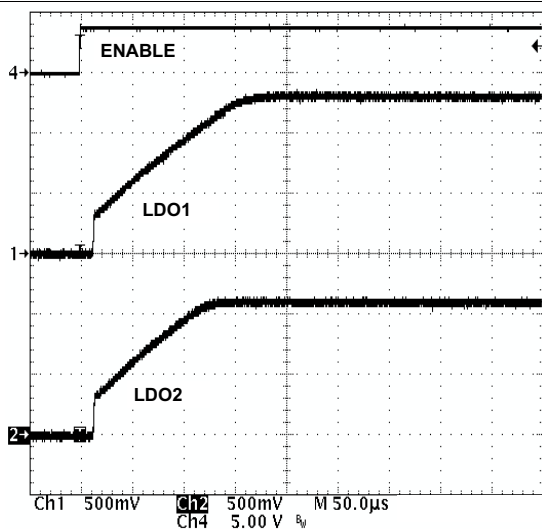


Figure 23. Start-Up LDO1 and LDO2

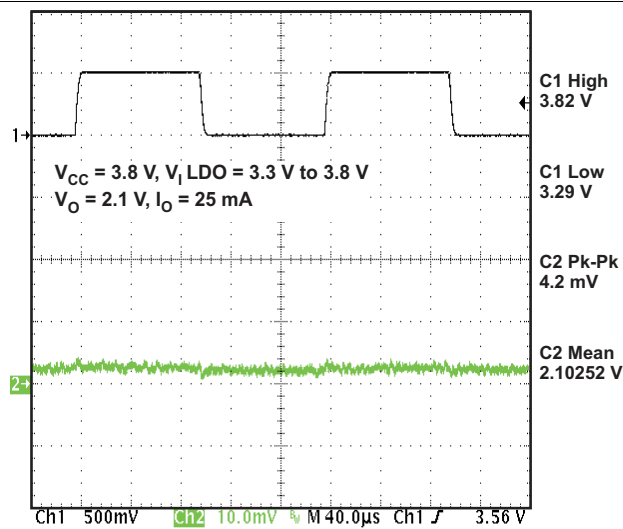


Figure 24. LDO1 Line Transient Response

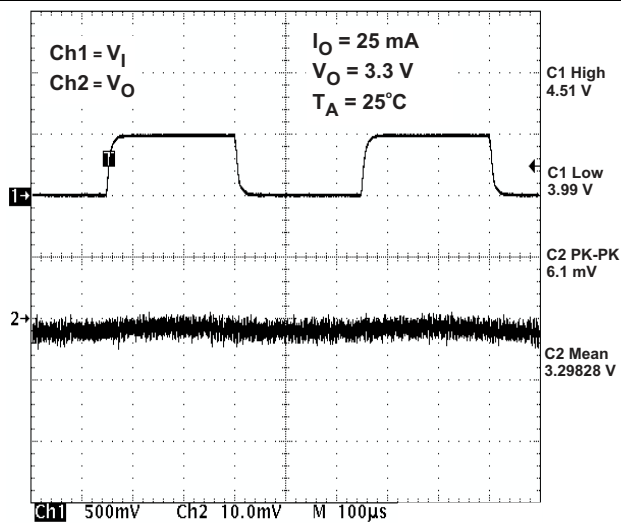


Figure 25. LDO2 Line Transient Response

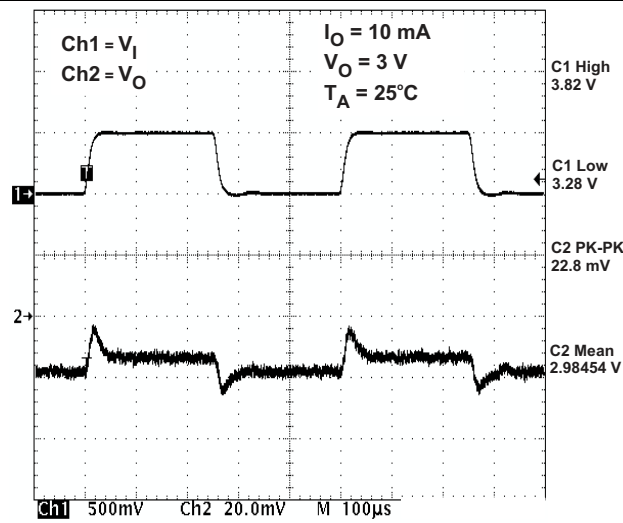


Figure 26. VRTC Line Transient Response

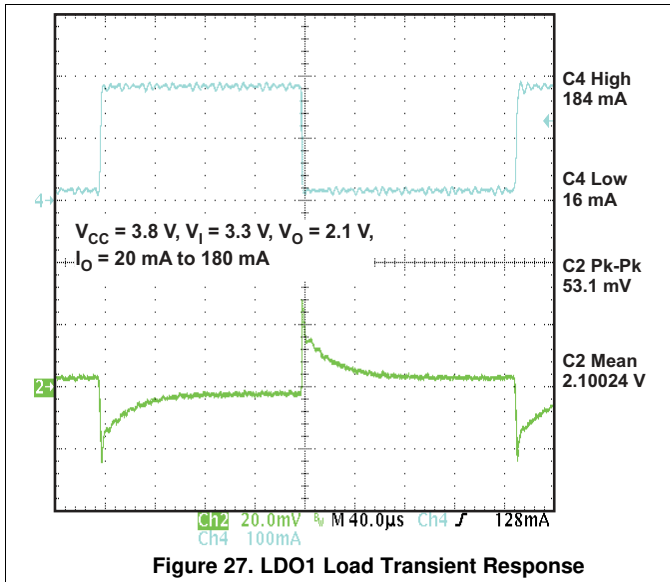


Figure 27. LDO1 Load Transient Response

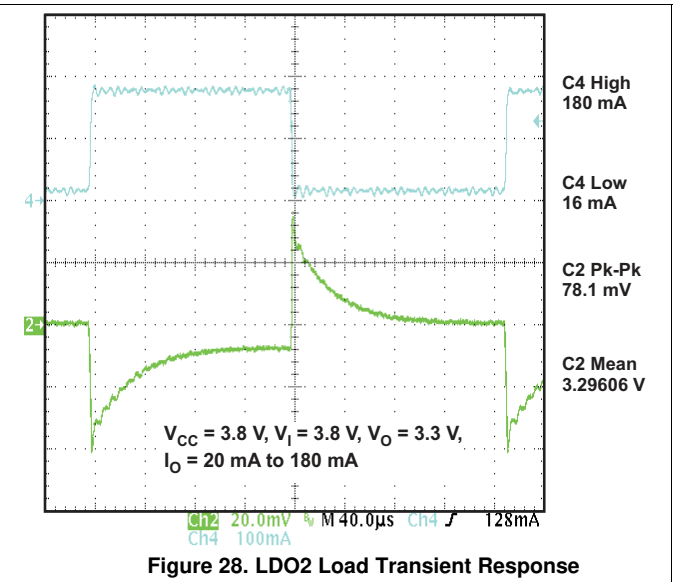


Figure 28. LDO2 Load Transient Response

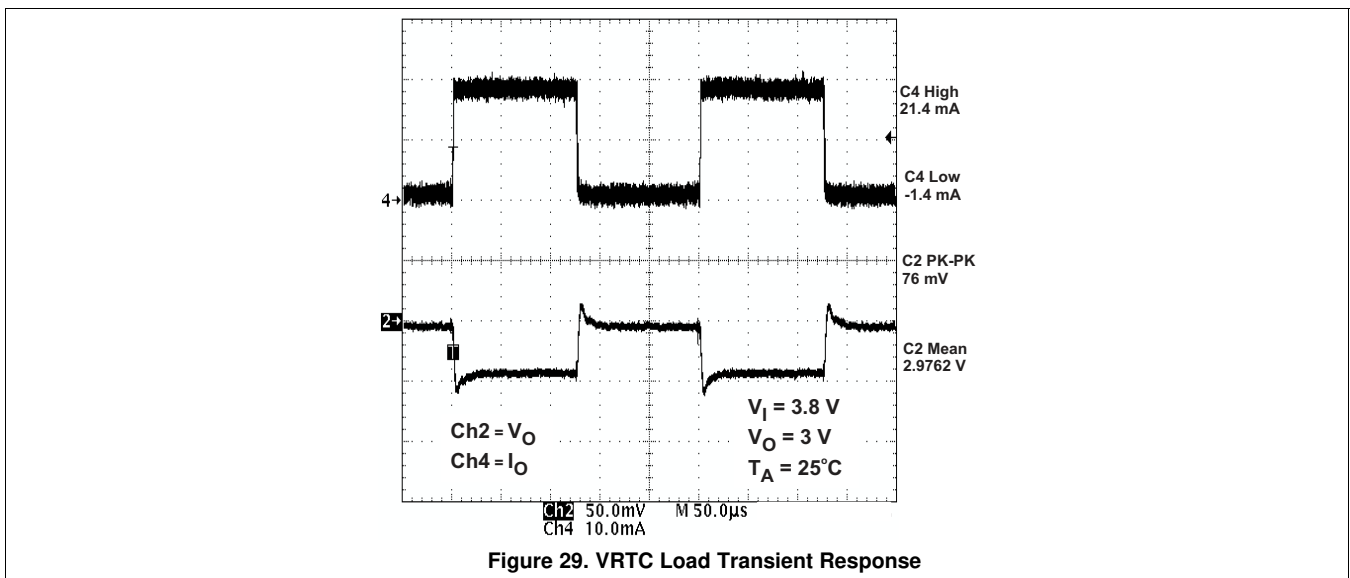


Figure 29. VRTC Load Transient Response

## 8 Detailed Description

### 8.1 Overview

TPS650231 has 5 regulator channels, 3 DCDCs and 2 LDOs. DCDC3 has dynamic voltage scaling feature, DVS, that allows for power reduction to CORE supplies during idle operation or over voltage during heavy-duty operation. With DVS and 2 more DCDCs plus 2 LDOs, the TPS650231 is ideal for CORE, Memory, IO, and peripheral power for the entire system of a wide range of suitable applications.

The device incorporates enables for the DCDCs and LDOs, I2C for device control, push-button and a reset interface that complete the system and allow for the TPS650231 to be adapted for different kinds of processors or FPGAs.

For noise-sensitive circuits, the DCDCs can be synchronized out of phase from one another, reducing the peak noise at the switching frequency. Each converter can be forced to operate in PWM mode to ensure constant switching frequency across the entire load range. However, for low-load efficiency performance the DCDCs automatically enter PSM mode which reduces the switching frequency when the load current is low, saving power at idle operation.

## 8.2 Functional Block Diagrams

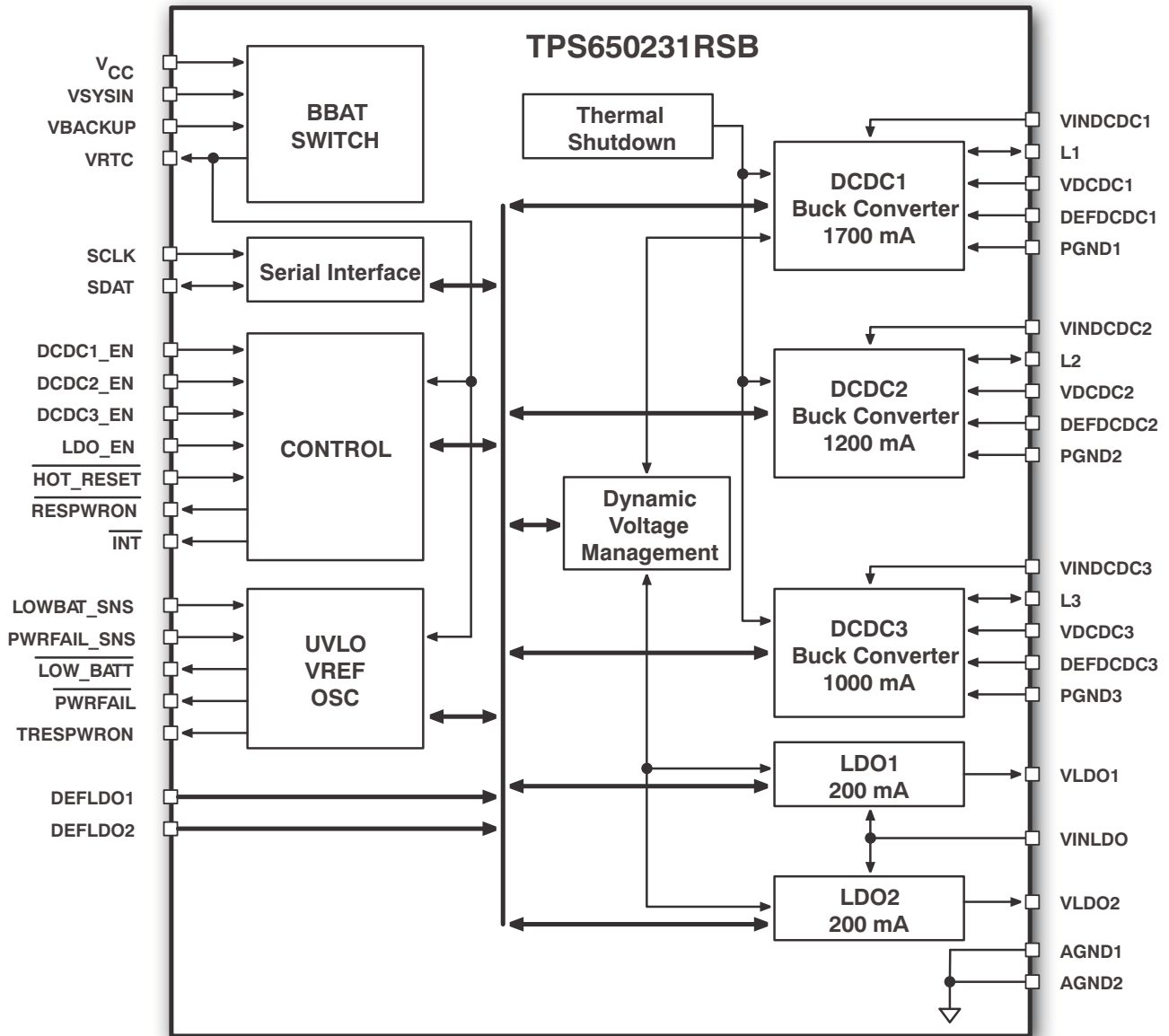


Figure 30. TPS650231 VQFN Package

Functional Block Diagrams (continued)

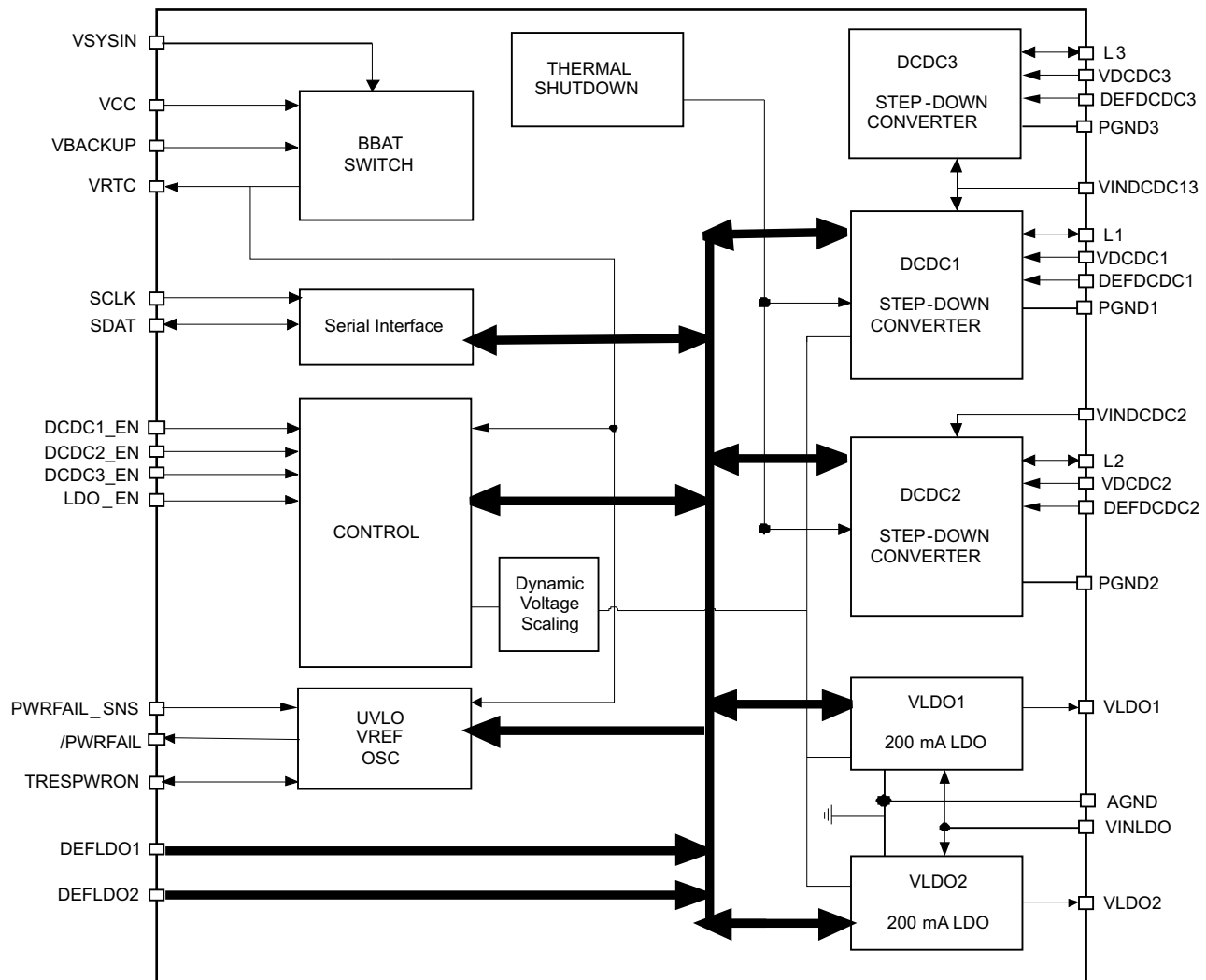


Figure 31. TPS650231 DSBGA Package

8.3 Feature Description

8.3.1 VRTC Output and Operation With or Without Backup Battery

The VRTC pin is an always-on output, intended to supply up to 30 mA to a permanently required rail (that is, for a real-time clock). The TPS650231 asserts the RESPWRON signal if VRTC drops below 2.4 V. VRTC is selected from a priority scheme based on the VSYSIN and VBACKUP inputs.

When the voltage at the VSYSIN pin exceeds 2.65 V, VRTC connects to the VSYSIN input through a PMOS switch and all other paths to VRTC are disabled. The PMOS switch drops a maximum of 375 mV at 30-mA, which must be considered when using VRTC. VSYSIN can be connected to any voltage source with the appropriate input voltage, including VCC or, if set to 3.3-V output, DCDC2 or DCDC3. When VSYSIN falls below 2.65 V or shorts to ground, the PMOS switch connecting VRTC and VSYSIN opens and VRTC then connects to either VBACKUP or the output of a dedicated 3-V or 30-mA LDO. Texas Instruments recommends connecting VSYSIN to VCC or ground, connecting VCC if a non-replaceable primary cell is connected to VBACKUP and ground if the VRTC output floats.

## Feature Description (continued)

If the PMOS switch between V<sub>SYSIN</sub> and V<sub>RTC</sub> is open and V<sub>BACKUP</sub> exceeds 2.65 V, V<sub>RTC</sub> connects to V<sub>BACKUP</sub> through a PMOS switch. The PMOS switch drops a maximum of 375 mV at 30 mA, which must be considered if using V<sub>RTC</sub>. A typical application may connect V<sub>BACKUP</sub> to a primary Li button cell, but any battery that provides a voltage between 2.65 V and 6 V (that is, a single Li-Ion cell or a single boosted NiMH battery) is acceptable, to supply the V<sub>RTC</sub> output.

### NOTE

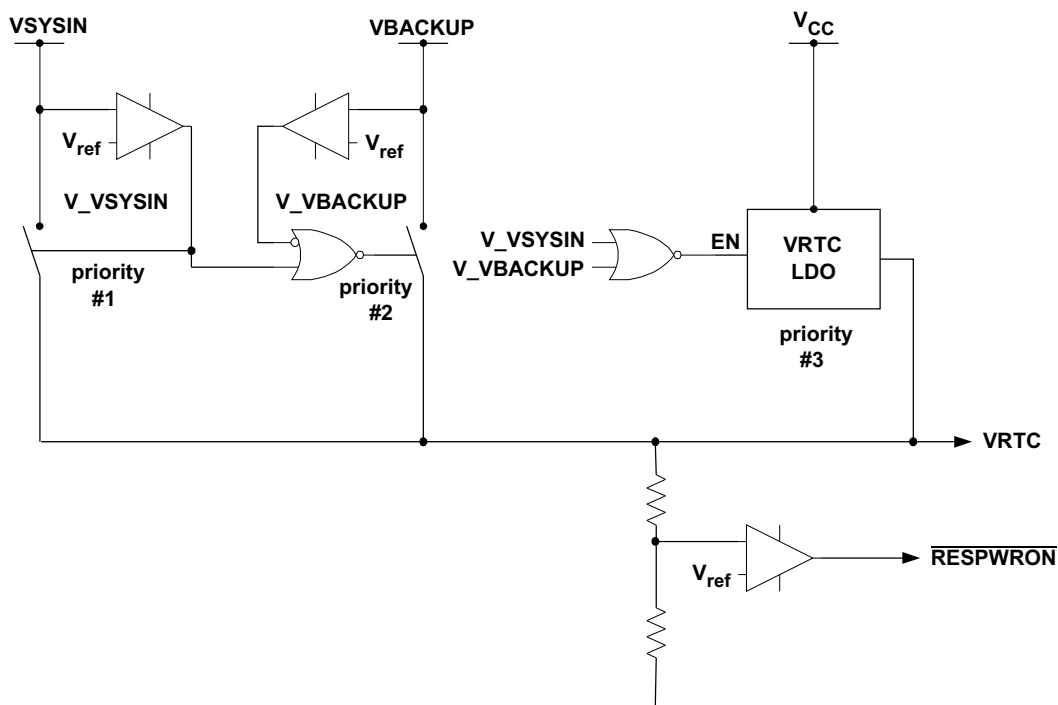
In systems with no backup battery, the V<sub>BACKUP</sub> pin must be connected to GND.

If the switches between V<sub>RTC</sub> and V<sub>SYSIN</sub> or V<sub>BACKUP</sub> are open, the dedicated 3-V or 30-mA LDO, driven from V<sub>CC</sub>, connects to V<sub>RTC</sub>. This LDO is disabled if the voltage at the V<sub>SYSIN</sub> input exceeds 2.65 V.

Inside TPS650231 there is a switch (V<sub>max</sub> switch) which selects the higher voltage between V<sub>CC</sub> and V<sub>BACKUP</sub>. This is used as the supply voltage for some basic functions. The functions powered from the output of the V<sub>max</sub> switch are:

- $\overline{\text{INT}}$  output
- $\overline{\text{RESPWRON}}$  output
- $\overline{\text{HOT\_RESET}}$  input
- $\overline{\text{LOW\_BATT}}$  output
- $\overline{\text{PWRFAIL}}$  output
- Enable pins for DC-DC converters, LDO1 and LDO2
- Undervoltage lockout comparator (UVLO)
- Reference system with low-frequency timing oscillators
- $\overline{\text{LOW\_BATT}}$  and  $\overline{\text{PWRFAIL}}$  comparators

The main 2.25-MHz oscillator, and the I<sup>2</sup>C interface are only powered from V<sub>CC</sub>.



- A. V<sub>VSYSIN</sub>, V<sub>VBACKUP</sub> thresholds: falling = 2.55 V, rising = 2.65 V ±3%
- B.  $\overline{\text{RESPWRON}}$  thresholds: falling = 2.4 V, rising = 2.52 V ±3%

**Figure 32. RTC and  $\overline{\text{RESPWRON}}$**



## Feature Description (continued)

### 8.3.2 Step-Down Converters, VDCDC1, VDCDC2, and VDCDC3

The TPS650231 incorporates three synchronous step-down converters operating typically at 2.25-MHz fixed-frequency pulse width modulation (PWM) at moderate to heavy-load currents. At light-load currents the converters automatically enter power save mode and operate with pulse frequency modulation (PFM). The VDCDC1 converter is capable of delivering 1.7-A output current, the VDCDC2 converter is capable of delivering 1.2-A, and the VDCDC3 converter delivers up to 800 mA.

The converter output voltages can be programmed through the DEFDCDC1, DEFDCDC2, and DEFDCDC3 pins. For DEFDCDC1 and DEFDCDC3, the pins can either be connected to GND, VCC, or to a resistor divider between the output voltage and GND.

The VDCDC1 converter defaults to 1.2 V or 1.6 V depending on the DEFDCDC1 configuration pin, if DEFDCDC1 is tied to ground the default is 1.2 V, if it is tied to VCC the default is 1.6 V. When the DEFDCDC1 pin is connected to a resistor divider, the output voltage can be set in the range of 0.6 V to VINDCDC1 V. See [Application Information](#) for more details. The core voltage can be reprogrammed through the serial interface in the range of 0.8 V to 1.6 V with a programmable slew rate. The converter is forced into PWM operation whilst any programmed voltage change is underway, whether the voltage is being increased or decreased. The DEFDCDC1 and DEFDCDC3 pins can be connected to GND, VCC, or to a resistor divider between the output voltage and GND. The DEFDCDC2 pin does not have the logic function in parallel and always needs to be connected with a resistor divider, the output voltage can be set in the range of 0.6 V to VINDCDC2 V.

The DEFDCDC2 pin does not have the logic function in parallel and always needs to be connected with a resistor divider, the output voltage can be set in the range of 0.6 V to VINDCDC2 V.

The VDCDC3 converter defaults to 1.8 V or 3.3 V depending on the DEFDCDC3 configuration pin. If DEFDCDC3 is tied to ground, the default is 1.8 V. If it is tied to VCC, the default is 3.3 V. When the DEFDCDC3 pin is connected to a resistor divider, the output voltage can be set in the range of 0.6 V to VINDCDC3 V. The step-down converter outputs (when enabled) are monitored by power-good comparators, the outputs of which are available through the serial interface. The outputs of the DC-DC converters can be optionally discharged through on-chip 300-Ω resistors when the DC-DC converters are disabled.

During PWM operation the converters use a unique fast response voltage mode controller scheme with input voltage feedforward to achieve good line and load regulation allowing the use of small ceramic input and output capacitors. At the beginning of each clock cycle initiated by the clock signal, the P-channel MOSFET switch is turned on and the inductor current ramps up until the comparator trips and the control logic turns off the switch. The current limit comparator also turns off the switch in case the current limit of the P-channel switch is exceeded. After the adaptive dead-time used to prevent shoot through current, the N-channel MOSFET rectifier is turned on and the inductor current ramps down. The next cycle is initiated by the clock signal again turning off the N-channel rectifier and turning on the P-channel switch.

The three DC-DC converters operate synchronized to each other, with the VDCDC1 converter as the master. A 180° phase shift between the VDCDC1 switch turn on and the VDCDC2 and a further 90° shift to the VDCDC3 switch turn on decreases the input RMS current and smaller input capacitors can be used. The phase of the three converters can be changed using the CON\_CTRL register.

### 8.3.3 Power Save Mode Operation

As the load current decreases, the converters enter the power save mode operation. During power save mode, the converters operate in a burst mode (PFM mode) with a frequency between 750 kHz and 2.25 MHz, nominal for one burst cycle. However, the frequency between different burst cycles depends on the actual load current and is typically far less than the switching frequency with a minimum quiescent current to maintain high efficiency.

## Feature Description (continued)

To optimize the converter efficiency at light load, the average current is monitored and if in PWM mode the inductor current remains below a certain threshold, then PSM is entered. The typical threshold to enter PSM is calculated with [Equation 1](#), [Equation 2](#), and [Equation 3](#).

$$I_{PFMDCDC1 \text{ enter}} = \frac{V_{INDCDC1}}{24 \Omega} \quad (1)$$

$$I_{PFMDCDC2 \text{ enter}} = \frac{V_{INDCDC2}}{26 \Omega} \quad (2)$$

$$I_{PFMDCDC3 \text{ enter}} = \frac{V_{INDCDC3}}{39 \Omega} \quad (3)$$

During the power save mode the output voltage is monitored with a comparator, and by maximum skip burst width. As the output voltage falls below the threshold, set to the nominal  $V_O$ , the P-channel switch turns on and the converter effectively delivers a constant current defined with [Equation 4](#), [Equation 5](#), and [Equation 6](#).

$$I_{PFMDCDC1 \text{ leave}} = \frac{V_{INDCDC1}}{18 \Omega} \quad (4)$$

$$I_{PFMDCDC2 \text{ leave}} = \frac{V_{INDCDC2}}{20 \Omega} \quad (5)$$

$$I_{PFMDCDC3 \text{ leave}} = \frac{V_{INDCDC3}}{29 \Omega} \quad (6)$$

If the load is below the delivered current then the output voltage rises until the same threshold is crossed in the other direction. All switching activity ceases, reducing the quiescent current to a minimum until the output voltage has again dropped below the threshold. The power save mode is exited, and the converter returns to PWM mode if either of the following conditions are met:

1. the output voltage drops 2% below the nominal  $V_O$  due to increasing load current
2. the PFM burst time exceeds  $16 \times 1 / f_s$  (7.11  $\mu$ s typical).

These control methods reduce the quiescent current to typically 14  $\mu$ A per converter, and the switching activity to a minimum, thus achieving the highest converter efficiency. Setting the comparator thresholds at the nominal output voltage at light-load current results in a low-output voltage ripple. The ripple depends on the comparator delay and the size of the output capacitor. Increasing capacitor values makes the output ripple tend to zero. The PSM is disabled through the I<sup>2</sup>C interface to force the individual converters to stay in fixed-frequency PWM mode.

### 8.3.4 Low-Ripple Mode

Setting bit 3 in register CON-CTRL to 1 enables the low-ripple mode for all of the DC-DC converters if operated in PFM mode. For an output current less than approximately 10 mA, the output voltage ripple in PFM mode is reduced, depending on the actual load current. The lower the actual output current on the converter, the lower the output ripple voltage. For an output current above 10 mA, there is only minor difference in output voltage ripple between PFM mode and low-ripple PFM mode. As this feature also increases switching frequency, it is used to keep the switching frequency above the audible range in PFM mode down to a low-output current.

### 8.3.5 Soft-Start

Each of the three converters has an internal soft-start circuit that limits the inrush current during start-up. The soft-start is realized by using a low current to initially charge the internal compensation capacitor. The soft-start time is typically 750  $\mu$ s if the output voltage ramps from 5% to 95% of the final target value. If the output is already precharged to some voltage when the converter is enabled, then this time is reduced proportionally. There is a short delay of typically 170  $\mu$ s between the converter being enabled and switching activity actually starting. This allows the converter to bias itself properly, to recognize if the output is precharged, and if so to prevent discharging of the output while the internal soft-start ramp catches up with the output voltage.

## Feature Description (continued)

### 8.3.6 100% Duty Cycle Low-Dropout Operation

The TPS650231 converters offer a low input-to-output voltage difference while still maintaining operation with the use of the 100% duty cycle mode. In this mode the P-channel switch is constantly turned on. This is particularly useful in battery-powered applications to achieve longest operation time by taking full advantage of the whole battery voltage range. The minimum input voltage required to maintain DC regulation depends on the load current and output voltage. It is calculated in [Equation 7](#).

$$V_{in\_min} = V_{out\_min} + I_{out\_max} \times (r_{DS(on)\_max} + R_L)$$

where

- $I_{out\_max}$  = maximum load current (Note: ripple current in the inductor is zero under these conditions)
- $r_{DS(on)\_max}$  = maximum P-channel switch  $r_{DS(on)}$
- $R_L$  = DC resistance of the inductor
- $V_{out\_min}$  = nominal output voltage minus 2% tolerance limit

(7)

### 8.3.7 Active Discharge When Disabled

When the VDCDC1, VDCDC2, and VDCDC3 converters are disabled, due to an UVLO, DCDC\_EN, or OVERTEMP condition, it is possible to actively pull down the outputs. This feature is disabled per default and is individually enabled through the CON\_CTRL2 register in the serial interface. When this feature is enabled, the VDCDC1, VDCDC2, and VDCDC3 outputs are discharged by a 300-Ω (typical) load which is active as long as the converters are disabled.

### 8.3.8 Power-Good Monitoring

All three step-down converters and both the LDO1 and LDO2 linear regulators have power-good comparators. Each comparator indicates when the relevant output voltage has dropped 10% below its target value with 5% hysteresis. The outputs of these comparators are available in the PGOODZ register through the serial interface. An interrupt is generated when any voltage rail drops below the 10% threshold. The comparators are disabled when the converters are disabled and the relevant PGOODZ register bits indicate that power is good.

### 8.3.9 Low-Dropout Voltage Regulators

The low-dropout voltage regulators are designed to operate well with low-value ceramic input and output capacitors. They operate with input voltages down to 1.5 V. The LDOs offer a maximum dropout voltage of 300 mV at rated output current. Each LDO supports a current limit feature. Both LDOs are enabled by the LDO\_EN pin, both LDOs can be disabled or programmed through the serial interface using the REG\_CTRL and LDO\_CTRL registers. The LDOs also have reverse conduction prevention. This allows the possibility to connect external regulators in parallel in systems with a backup battery. The TPS650231 step-down and LDO voltage regulators automatically power down when the  $V_{CC}$  voltage drops below the UVLO threshold or when the junction temperature rises above 160°C.

### 8.3.10 Undervoltage Lockout

The undervoltage lockout circuit for the five regulators on the TPS650231 prevents the device from malfunctioning at low-input voltages and from excessive discharge of the battery. It disables the converters and LDOs. The UVLO circuit monitors the VCC pin, the threshold is set internally to 2.35 V with 5% (120 mV) hysteresis. Consider this current if an external RC filter is used at the VCC pin to remove switching noise from the TPS650231 internal analog circuitry supply.

---

#### NOTE

When any of the DC-DC converters are running, there is an input current at the VCC pin, which is up to 3 mA when all three converters are running in PWM mode.

---

## Feature Description (continued)

### 8.3.11 Power-Up Sequencing

The TPS650231 power-up sequencing is designed to be entirely flexible and customer-driven. This is achieved by providing separate enable pins for each switch-mode converter, and a common enable signal for the LDOs. The relevant control pins are described in [Table 2](#).

**Table 2. Control Pins and Status Outputs for DC-DC Converters**

PIN NAME	I/O	FUNCTION
DEFDCDC3	I	Defines the default voltage of the VDCDC3 switching converter. DEFDCDC3 = 0 defaults VDCDC3 to 1.8 V, DEFDCDC3 = VCC defaults VDCDC3 to 3.3 V.
DEFDCDC2	I	Feedback pin of the VDCDC2 switching converter, connected to a resistive divider. The output voltage can be set between 0.6 V and VINDCDC2 V.
DEFDCDC1	I	Defines the default voltage of the VDCDC1 switching converter. DEFDCDC1 = 0 defaults VDCDC1 to 1.2 V, DEFDCDC1 = VCC defaults VDCDC1 to 1.6 V.
DCDC3_EN	I	Set DCDC3_EN = 0 to disable and DCDC3_EN = 1 to enable the VDCDC3 converter
DCDC2_EN	I	Set DCDC2_EN = 0 to disable and DCDC2_EN = 1 to enable the VDCDC2 converter
DCDC1_EN	I	Set DCDC1_EN = 0 to disable and DCDC1_EN = 1 to enable the VDCDC1 converter
$\overline{\text{HOT\_RESET}}$	I	TPS650231RSB only: The $\overline{\text{HOT\_RESET}}$ pin generates a reset ( $\overline{\text{RESPWRON}}$ ) for the processor. $\overline{\text{HOT\_RESET}}$ does not alter any TPS650231 settings except the output voltage of VDCDC1. Activating $\overline{\text{HOT\_RESET}}$ sets the voltage of VDCDC1 to its default value defined with the DEFDCDC1 pin. $\overline{\text{HOT\_RESET}}$ is internally de-bounced by the TPS650231.
$\overline{\text{RESPWRON}}$	O	TPS650231RSB only: $\overline{\text{RESPWRON}}$ is held low when power is initially applied to the TPS650231. The VRTC voltage is monitored: $\overline{\text{RESPWRON}}$ is low when VRTC < 2.4 V and remains low for a time defined by the external capacitor at the TRESPWRON pin. $\overline{\text{RESPWRON}}$ can also be forced low by activation of the $\overline{\text{HOT\_RESET}}$ pin.
TRESPWRON	I	Connect a capacitor here to define the RESET time at the $\overline{\text{RESPWRON}}$ pin (1 nF typically gives 100 ms).

### 8.3.12 System Reset + Control Signals

The  $\overline{\text{RESPWRON}}$  signal can be used as a global reset for the application. It is an open-drain output. The  $\overline{\text{RESPWRON}}$  signal is generated according to the power good comparator of VRTC, and remains low for  $t_{\text{nrspwrn}}$  seconds after VRTC has risen above 2.52 V (falling threshold is 2.4 V, 5% hysteresis).  $t_{\text{nrspwrn}}$  is set by an external capacitor at the TRESPWRON pin. 1 nF gives typically 100 ms.  $\overline{\text{RESPWRON}}$  is also triggered by the  $\overline{\text{HOT\_RESET}}$  input. This input is internally debounced, with a filter time of typically 30 ms.

The  $\overline{\text{PWRFAIL}}$  and  $\overline{\text{LOW\_BAT}}$  signals are generated by two voltage detectors using the PWRFAIL\_SNS and LOWBAT\_SNS input signals. Each input signal is compared to a 1-V threshold (falling edge) with 5% (50 mV) hysteresis.

The DCDC1 converter is reset to its default output voltage defined by the DEFDCDC1 input, when  $\overline{\text{HOT\_RESET}}$  is asserted. Other I<sup>2</sup>C registers are not affected. Generally, the DCDC1 converter is set to its default voltage with one of these conditions:  $\overline{\text{HOT\_RESET}}$  active, VRTC lower than its threshold voltage, undervoltage lockout (UVLO) condition, or  $\overline{\text{RESPWRON}}$  active.

The  $\overline{\text{RESPWRON}}$ ,  $\overline{\text{HOT\_RESET}}$ ,  $\overline{\text{LOW\_BAT}}$ , and LOWBAT\_SNS pins are not available in TPS650231YFF.

#### 8.3.12.1 DEFLDO1 and DEFLDO2

These two pins are used to set the default output voltage of the two 200-mA LDOs. The digital value applied to the pins is latched during power up and determines the initial output voltage according to [Table 3](#). The voltage of both LDOs can be changed during operation with the I<sup>2</sup>C interface as described in the interface description.

**Table 3. LDO1 and LDO2 Default Voltage Options**

DEFLDO2	DEFLDO1	VLDO1	VLDO2
0	0	1.3 V	3.3 V
0	1	2.8 V	3.3 V
1	0	1.3 V	1.8 V
1	1	2.1 V	3.3 V

### 8.3.12.2 Interrupt Management and the $\overline{\text{INT}}$ Pin

The  $\overline{\text{INT}}$  pin combines the outputs of the PGOOD comparators from each DC-DC converter and the LDOs. The  $\overline{\text{INT}}$  pin is used as a POWER\_OK pin to indicate when all enabled supplies are in regulation. The  $\overline{\text{INT}}$  pin remains active (low state) during power up as long as all enabled power rails are below their regulation limit. When the last enabled power rail is within regulation, the  $\overline{\text{INT}}$  pin transitions to a high state.

During operation, if one of the enabled supplies goes out of regulation,  $\overline{\text{INT}}$  transitions to a low state, and the corresponding bit in the PGOODZ register goes high. If the supply goes back to its regulation limits,  $\overline{\text{INT}}$  transitions back to a high state.

While  $\overline{\text{INT}}$  is in an active-low state, reading the PGOODZ register through the I<sup>2</sup>C bus forces  $\overline{\text{INT}}$  into a high-Z state. Because this pin requires an external pullup resistor, the  $\overline{\text{INT}}$  pin transitions to a logic high state even though the supply in question is still out of regulation. The corresponding bit in the PGOODZ register still indicates that the power rail is out of regulation.

Interrupts can be masked using the MASK register; default operation is not to mask any DCDC or LDO interrupts because this provides the POWER\_OK function. If none of the DCDC converters or LDOs are enabled,  $\overline{\text{INT}}$  defaults to a low state independently of the settings of the MASK register.

## 8.4 Device Functional Modes

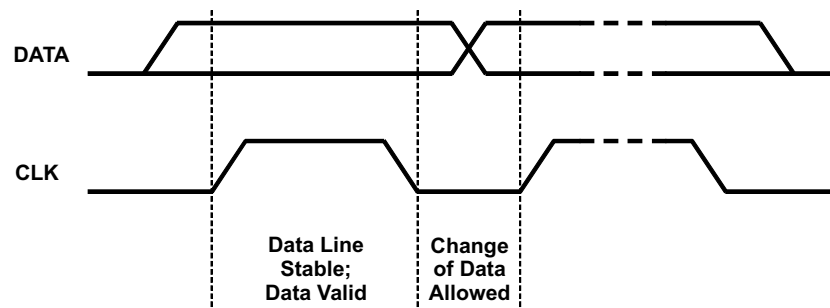
The TPS650231 device is in the ON or the OFF mode. The OFF mode is entered when the voltage on VCC is below the UVLO threshold, 2.35 V (typically). When the voltage at VCC has increased above UVLO, the device enters ON mode. In the ON mode, the DCDCs and LDOs are available for use.

## 8.5 Programming

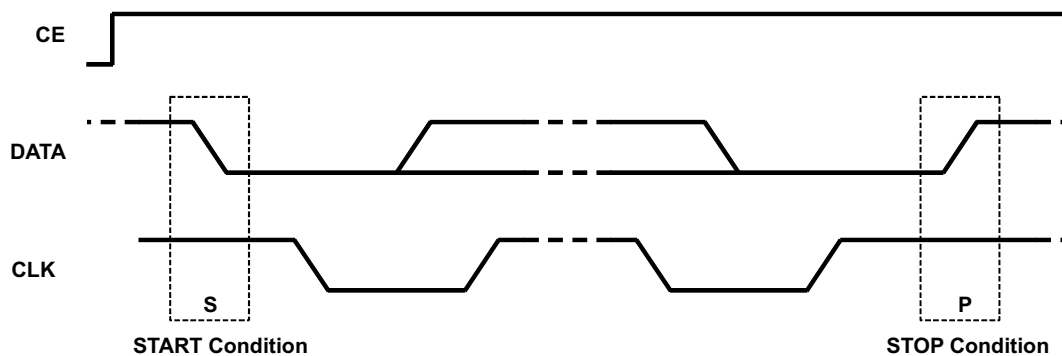
### 8.5.1 Serial Interface

The serial interface is compatible with the standard and fast mode I<sup>2</sup>C specifications, allowing transfers at up to 400 kHz. The interface adds flexibility to the power supply solution, enabling most functions to be programmed to new values depending on the instantaneous application requirements and charger status to be monitored. Register contents remain intact as long as V<sub>CC</sub> remains above 2 V. The TPS650231 has a 7-bit address: 1001000, other addresses are available upon contact with the factory. Attempting to read data from the register addresses not listed in this section results in FFh being read out.

For normal data transfer, DATA is allowed to change only when CLK is low. Changes when CLK is high are reserved for indicating the start and stop conditions. During data transfer, the data line must remain stable whenever the clock line is high. There is one clock pulse per bit of data. Each data transfer is initiated with a start condition and terminated with a stop condition. When addressed, the TPS650231 device generates an acknowledge bit after the reception of each byte. The master device (microprocessor) must generate an extra clock pulse that is associated with the acknowledge bit. The TPS650231 device must pull down the DATA line during the acknowledge clock pulse so that the DATA line is a stable low during the high period of the acknowledge clock pulse. The DATA line is a stable low during the high period of the acknowledge-related clock pulse. Setup and hold times must be taken into account. During read operations, a master must signal the end of data to the slave by not generating an acknowledge bit on the last byte that was clocked out of the slave. In this case, the slave TPS650231 device must leave the data line high to enable the master to generate the stop condition

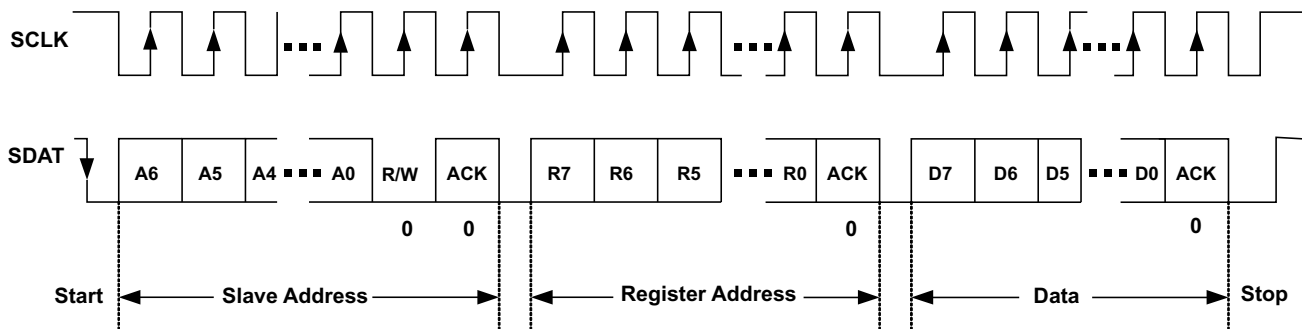


**Figure 33. Bit Transfer on the Serial Interface**



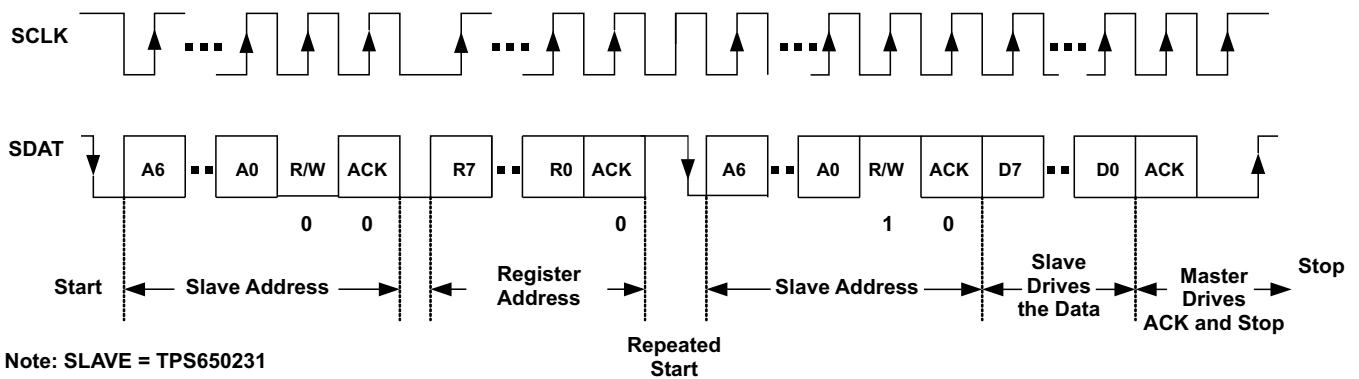
**Figure 34. START and STOP Conditions**

Programming (continued)



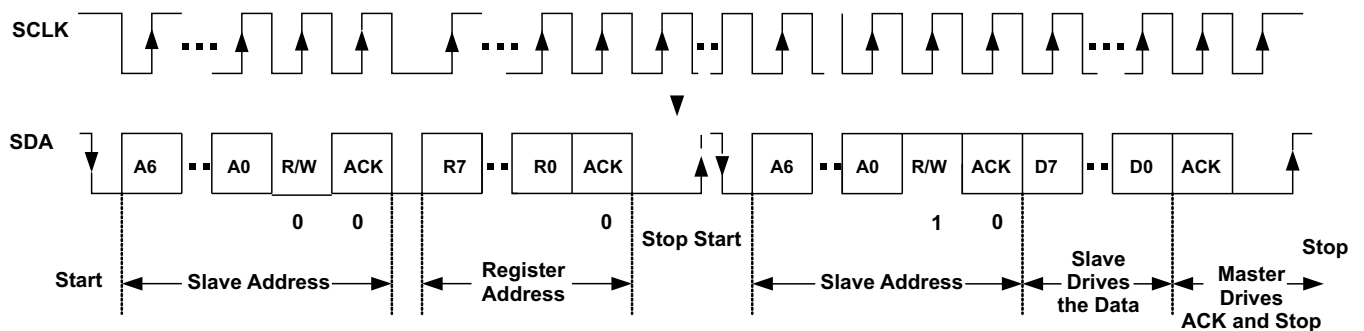
Note: SLAVE = TPS650231

Figure 35. Serial I/F WRITE to TPS650231 Device



Note: SLAVE = TPS650231

Figure 36. Serial I/F READ from TPS650231: Protocol A



Note: SLAVE = TPS650231

Figure 37. Serial I/F READ from TPS650231: Protocol B



## 8.6 Register Maps

### 8.6.1 VERSION Register Address: 00h (Read Only)

**Table 4. VERSION Register**

VERSION	B7	B6	B5	B4	B3	B2	B1	B0
Bit name and function	0	0	1	0	0	0	1	1
Read/write	R	R	R	R	R	R	R	R

### 8.6.2 PGOODZ Register Address: 01h (Read Only)

**Table 5. PGOODZ Register**

PGOODZ	B7	B6	B5	B4	B3	B2	B1	B0
Bit name and function	PWRFAILZ	LOWBATTZ	PGOODZ VDCDC1	PGOODZ VDCDC2	PGOODZ VDCDC3	PGOODZ LDO2	PGOODZ LDO1	–
Set by signal	PWRFAIL	LOWBATT	PGOODZ VDCDC1	PGOODZ VDCDC2	PGOODZ VDCDC3	PGOODZ LDO2	PGOODZ LDO1	–
Default value loaded	PWRFAILZ	LOWBATTZ	PGOOD VDCDC1	PGOOD VDCDC2	PGOOD VDCDC3	PGOOD LDO2	PGOOD LDO1	–
Read/write	R	R	R	R	R	R	R	R

**Bit 7 PWRFAILZ:**

0 = indicates that the PWRFAIL\_SNS input voltage is above the 1-V threshold.

1 = indicates that the PWRFAIL\_SNS input voltage is below the 1-V threshold.

**Bit 6 LOWBATTZ:**

0 = indicates that the LOWBATT\_SNS input voltage is above the 1-V threshold.

1 = indicates that the LOWBATT\_SNS input voltage is below the 1-V threshold.

**Bit 5 PGOODZ VDCDC1:**

0 = indicates that the VDCDC1 converter output voltage is within its nominal range. This bit is zero if the VDCDC1 converter is disabled.

1 = indicates that the VDCDC1 converter output voltage is below its target regulation voltage

**Bit 4 PGOODZ VDCDC2:**

0 = indicates that the VDCDC2 converter output voltage is within its nominal range. This bit is zero if the VDCDC2 converter is disabled.

1 = indicates that the VDCDC2 converter output voltage is below its target regulation voltage

**Bit 3 PGOODZ VDCDC3:**

0 = indicates that the VDCDC3 converter output voltage is within its nominal range. This bit is zero if the VDCDC3 converter is disabled and during a DVM controlled output voltage transition

1 = indicates that the VDCDC3 converter output voltage is below its target regulation voltage

**Bit 2 PGOODZ LDO2:**

0 = indicates that the LDO2 output voltage is within its nominal range. This bit is zero if LDO2 is disabled.

1 = indicates that LDO2 output voltage is below its target regulation voltage

**Bit 1 PGOODZ LDO1:**

0 = indicates that the LDO1 output voltage is within its nominal range. This bit is zero if LDO1 is disabled.

1 = indicates that the LDO1 output voltage is below its target regulation voltage



### 8.6.3 MASK Register Address: 02h (Read or Write), Default Value: C0h

**Table 6. MASK Register**

MASK	B7	B6	B5	B4	B3	B2	B1	B0
Bit name and function	MASK PWRFAILZ	MASK LOWBATTZ	MASK VDCDC1	MASK VDCDC2	MASK VDCDC3	MASK LDO2	MASK LDO1	–
Default	1	1	0	0	0	0	0	0
Default value loaded	UVLO	UVLO	UVLO	UVLO	UVLO	UVLO	UVLO	–
Read/write	R/W	R/W	R/W	R/W	R/W	R/W	R/W	–

The MASK register can be used to mask particular fault conditions from appearing at the  $\overline{\text{INT}}$  pin. MASK<n> = 1 masks PGOODZ<n>.

### 8.6.4 REG\_CTRL Register Address: 03h (Read or Write), Default Value: FFh

The REG\_CTRL register is used to disable or enable the power supplies through the serial interface. The contents of the register are logically AND'ed with the enable pins to determine the state of the supplies. A UVLO condition resets the REG\_CTRL to 0xFF, so the state of the supplies defaults to the state of the enable pin. The REG\_CTRL bits are automatically reset to default when the corresponding enable pin is low.

**Table 7. REG\_CTRL Register**

REG_CTRL	B7	B6	B5	B4	B3	B2	B1	B0
Bit name and function	–	–	VDCDC1 ENABLE	VDCDC2 ENABLE	VDCDC3 ENABLE	LDO2 ENABLE	LDO1 ENABLE	–
Default	1	1	1	1	1	1	1	1
Set by signal	–	–	DCDC1_ENZ	DCDC2_ENZ	DCDC3_ENZ	LDO_ENZ	LDO_ENZ	–
Default value loaded	–	–	UVLO	UVLO	UVLO	UVLO	UVLO	–
Read/write	–	–	R/W	R/W	R/W	R/W	R/W	–

#### Bit 5 VDCDC1 ENABLE

DCDC1 Enable. This bit is logically AND'ed with the state of the DCDC1\_EN pin to turn on the DCDC1 converter. Reset to 1 by a UVLO condition, the bit can be written to 0 or 1 through the serial interface. The bit is reset to 1 when the pin DCDC1\_EN is pulled to GND, allowing DCDC1 to turn on when DCDC1\_EN returns high.

#### Bit 4 VDCDC2 ENABLE

DCDC2 Enable. This bit is logically AND'ed with the state of the DCDC2\_EN pin to turn on the DCDC2 converter. Reset to 1 by a UVLO condition, the bit can be written to 0 or 1 through the serial interface. The bit is reset to 1 when the pin DCDC2\_EN is pulled to GND, allowing DCDC2 to turn on when DCDC2\_EN returns high.

#### Bit 3 VDCDC3 ENABLE

DCDC3 Enable. This bit is logically AND'ed with the state of the DCDC3\_EN pin to turn on the DCDC3 converter. Reset to 1 by a UVLO condition, the bit can be written to 0 or 1 through the serial interface. The bit is reset to 1 when the pin DCDC3\_EN is pulled to GND, allowing DCDC3 to turn on when DCDC3\_EN returns high.

#### Bit 2 LDO2 ENABLE

LDO2 Enable. This bit is logically AND'ed with the state of the LDO2\_EN pin to turn on LDO2. Reset to 1 by a UVLO condition, the bit can be written to 0 or 1 through the serial interface. The bit is reset to 1 when the pin LDO\_EN is pulled to GND, allowing LDO2 to turn on when LDO\_EN returns high.

#### Bit 1 LDO1 ENABLE

LDO1 Enable. This bit is logically AND'ed with the state of the LDO1\_EN pin to turn on LDO1. Reset to 1 by a UVLO condition, the bit can be written to 0 or 1 through the serial interface. The bit is reset to 1 when the pin LDO\_EN is pulled to GND, allowing LDO1 to turn on when LDO\_EN returns high.

### 8.6.5 CON\_CTRL Register Address: 04h (Read or Write), Default Value: B1h

**Table 8. CON\_CTRL Register**

CON_CTRL	B7	B6	B5	B4	B3	B2	B1	B0
Bit name and function	DCDC2 PHASE1	DCDC2 PHASE0	DCDC3 PHASE1	DCDC3 PHASE0	LOW RIPPLE	FPWM DCDC2	FPWM DCDC1	FPWM DCDC3
Default	1	0	1	1	0	0	0	0
Default value loaded	UVLO	UVLO	UVLO	UVLO	UVLO	UVLO	UVLO	UVLO
Read/write	R/W	R/W	R/W	R/W	R/W	R/W	R/W	R/W

The CON\_CTRL register is used to force any or all of the converters into forced PWM operation, when low-output voltage ripple is vital. It is also used to control the phase shift between the three converters to minimize the input rms current, hence reduce the required input blocking capacitance. The DCDC1 converter is taken as the reference and consequently has a fixed zero phase shift.

**Table 9. DCDC2 and DCDC3 Phase Delay**

CON_CTRL<7:6>	DCDC2 CONVERTER DELAYED BY	CON_CTRL<5:4>	DCDC3 CONVERTER DELAYED BY
00	zero	00	zero
01	1/4 cycle	01	1/4 cycle
10	1/2 cycle	10	1/2 cycle
11	3/4 cycle	11	3/4 cycle

**Bit 3 LOW RIPPLE:**

- 0 = PFM mode operation optimized for high efficiency for all converters
- 1 = PFM mode operation optimized for low-output voltage ripple for all converters

**Bit 2 FPWM DCDC2:**

- 0 = DCDC2 converter operates in PWM or PFM mode
- 1 = DCDC2 converter is forced into fixed-frequency PWM mode

**Bit 1 FPWM DCDC1:**

- 0 = DCDC1 converter operates in PWM or PFM mode
- 1 = DCDC1 converter is forced into fixed-frequency PWM mode

**Bit 0 FPWM DCDC3:**

- 0 = DCDC3 converter operates in PWM or PFM mode
- 1 = DCDC3 converter is forced into fixed-frequency PWM mode

**8.6.6 CON\_CTRL2 Register Address: 05h (Read or Write), Default Value: 40h**
**Table 10. CON\_CTRL2 Register**

CON_CTRL2	B7	B6	B5	B4	B3	B2	B1	B0
Bit name and function	GO	Core adj allowed	–	–	–	DCDC2 discharge	DCDC1 discharge	DCDC3 discharge
Default	0	1	0	0	0	0	0	0
Default value loaded	UVLO + DONE	RESET(1)	–	–	–	UVLO	UVLO	UVLO
Read/write	R/W	R/W	–	–	–	R/W	R/W	R/W

The CON\_CTRL2 register can be used to take control the inductive converters.

RESET(1): CON\_CTRL2[6] is reset to its default value by one of these events:

- Undervoltage lockout (UVLO)
- $\overline{\text{HOT\_RESET}}$  pulled low
- $\overline{\text{RESPWRON}}$  active
- VRTC below threshold

Bit 7 GO:

0 = no change in the output voltage for the DCDC1 converter

1 = the output voltage of the DCDC1 converter is changed to the value defined in DEFCORE with the slew rate defined in DEFSLEW. This bit is automatically cleared when the DVM transition is complete. The transition is considered complete in this case when the desired output voltage code has been reached, not when the VDCDC1 output voltage is actually in regulation at the desired voltage.

Bit 6 CORE ADJ Allowed:

0 = the output voltage is set with the I<sup>2</sup>C register

1 = DEFDCDC1 is either connected to GND or VCC or an external voltage divider. When connected to GND or VCC, VDCDC1 defaults to 1.2 V or 1.6 V respectively at start-up

Bit 2– 0 0 = the output capacitor of the associated converter is not actively discharged when the converter is disabled

1 = the output capacitor of the associated converter is actively discharged when the converter is disabled. This decreases the fall time of the output voltage at light load

**8.6.7 DEFCORE Register Address: 06h (Read or Write), Default Value: 14h/1Eh**
**Table 11. DEFCORE Register**

DEFCORE	B7	B6	B5	B4	B3	B2	B1	B0
Bit name and function	–	–	–	CORE4	CORE3	CORE2	CORE1	CORE0
Default	0	0	0	1	DEFDCDC1	DEFDCDC1	DEFDCDC1	DEFDCDC1
Default value loaded	–	–	–	RESET(1)	RESET(1)	RESET(1)	RESET(1)	RESET(1)
Read/write	–	–	–	R/W	R/W	R/W	R/W	R/W

RESET(1): DEFCORE is reset to its default value by one of these events:

- Undervoltage lockout (UVLO)
- $\overline{\text{HOT\_RESET}}$  pulled low
- $\overline{\text{RESPWRON}}$  active
- VRTC below threshold

**Table 12. DCDC1 DVS Voltages**

CORE4	CORE3	CORE2	CORE1	CORE0	VDCDC1		CORE4	CORE3	CORE2	CORE1	CORE0	VDCDC1
0	0	0	0	0	0.8 V		1	0	0	0	0	1.2 V
0	0	0	0	1	0.825 V		1	0	0	0	1	1.225 V
0	0	0	1	0	0.85 V		1	0	0	1	0	1.25 V
0	0	0	1	1	0.875 V		1	0	0	1	1	1.275 V
0	0	1	0	0	0.9 V		1	0	1	0	0	1.3 V
0	0	1	0	1	0.925 V		1	0	1	0	1	1.325 V
0	0	1	1	0	0.95 V		1	0	1	1	0	1.35 V
0	0	1	1	1	0.975 V		1	0	1	1	1	1.375 V
0	1	0	0	0	1 V		1	1	0	0	0	1.4 V
0	1	0	0	1	1.025 V		1	1	0	0	1	1.425 V
0	1	0	1	0	1.05 V		1	1	0	1	0	1.45 V
0	1	0	1	1	1.075 V		1	1	0	1	1	1.475 V
0	1	1	0	0	1.1 V		1	1	1	0	0	1.5 V
0	1	1	0	1	1.125 V		1	1	1	0	1	1.525 V
0	1	1	1	0	1.15 V		1	1	1	1	0	1.55 V
0	1	1	1	1	1.175 V		1	1	1	1	1	1.6 V

**8.6.8 DEFSLEW Register Address: 07h (Read or Write), Default Value: 06h**
**Table 13. DEFSLEW Register**

DEFSLEW	B7	B6	B5	B4	B3	B2	B1	B0
Bit name and function	–	–	–	–	–	SLEW2	SLEW1	SLEW0
Default	–	–	–	–	–	1	1	0
Default value loaded	–	–	–	–	–	UVLO	UVLO	UVLO
Read/write	–	–	–	–	–	R/W	R/W	R/W

**Table 14. DCDC1 DVS Slew Rate**

SLEW2	SLEW1	SLEW0	VDCDC1 SLEW RATE
0	0	0	0.225 mV/μs
0	0	1	0.45 mV/μs
0	1	0	0.9 mV/μs
0	1	1	1.8 mV/μs
1	0	0	3.6 mV/μs
1	0	1	7.2 mV/μs
1	1	0	14.4 mV/μs
1	1	1	Immediate

**8.6.9 LDO\_CTRL Register Address: 08h (Read or Write), Default Value: Set with DEFLDO1 and DEFLDO2**
**Table 15. LDO\_CTRL Register**

LDO_CTRL	B7	B6	B5	B4	B3	B2	B1	B0
Bit name and function	RSVD	LDO2_2	LDO2_1	LDO2_0	RSVD	LDO1_2	LDO1_1	LDO1_0
Default	–	DEFLDOx	DEFLDOx	DEFLDOx	–	DEFLDOx	DEFLDOx	DEFLDOx
Default value loaded	–	UVLO	UVLO	UVLO	–	UVLO	UVLO	UVLO
Read/write	–	R/W	R/W	R/W	–	R/W	R/W	R/W

The LDO\_CTRL registers can be used to set the output voltage of LDO1 and LDO2. LDO\_CTRL[7] and LDO\_CTRL[3] are reserved and must always be written to 0.

The default voltage is set with DEFLDO1 and DEFLDO2 pins as described in [Table 3](#).

**Table 16. LDO2 and LDO1 I2C Voltage Options**

LDO2_2	LDO2_1	LDO2_0	LDO2 OUTPUT VOLTAGE		LDO1_2	LDO1_1	LDO1_0	LDO1 OUTPUT VOLTAGE
0	0	0	1.05 V		0	0	0	1 V
0	0	1	1.2 V		0	0	1	1.1 V
0	1	0	1.3 V		0	1	0	1.3 V
0	1	1	1.8 V		0	1	1	2.1 V
1	0	0	2.5 V		1	0	0	2.2 V
1	0	1	2.8 V		1	0	1	2.6 V
1	1	0	3.0 V		1	1	0	2.8 V
1	1	1	3.3 V		1	1	1	3.15 V

## 9 Application and Implementation

### NOTE

Information in the following applications sections is not part of the TI component specification, and TI does not warrant its accuracy or completeness. TI's customers are responsible for determining suitability of components for their purposes. Customers should validate and test their design implementation to confirm system functionality.

### 9.1 Application Information

#### 9.1.1 Input Voltage Connection

The low power section of the control circuit for the step-down converters DCDC1, DCDC2, and DCDC3 is supplied by the VCC pin while the circuitry with high power such as the power stage is powered from the VINDCDC1, VINDCDC2, and VINDCDC3 pins. For proper operation of the step-down converters, VINDCDC1, VINDCDC2, VINDCDC3, and VCC need to be tied to the same voltage rail. Step-down converters that are planned to be not used, still need to be powered from their input pin on the same rails than the other step-down converters and VCC.

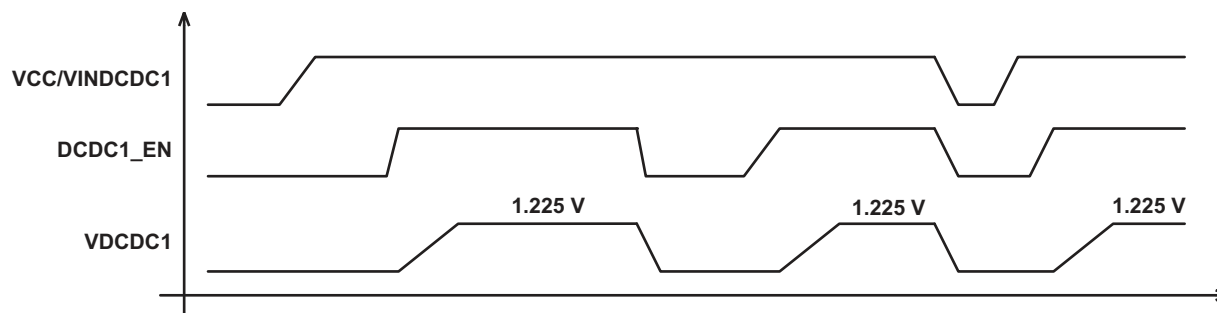
LDO1 and LDO2 share a supply voltage pin which can be powered from the  $V_{CC}$  rails or from a voltage lower than  $V_{CC}$ , for example, the output of one of the step-down converters as long as it is operated within the input voltage range of the LDOs. If both LDOs are not used, the VINLDO pin can be tied to GND.

#### 9.1.2 Unused Regulators

In case a step-down converter is not used, its input supply voltage pin VINDCDCx still must be connected to the  $V_{CC}$  rail along with supply input of the other step-down converters. TI recommends closing the control loop such that an inductor and output capacitor is added in the same way as it would be when operated normally. If one of the LDOs is not used, its output capacitor must be added as well. If both LDOs are not used, the input supply pin as well as the output pins of the LDOs (VINLDO, VLDO1, VLDO2) must be tied to GND.

#### 9.1.3 Reset Condition of DCDC1

If DEFDCDC1 is connected to ground and DCDC1\_EN is pulled high after VINDCDC1 is applied, the output voltage of DCDC1 defaults to 1.225 V instead of 1.2 V (high by 2%). [Figure 38](#) illustrates the problem.



**Figure 38. Default DCDC1**

### Application Information (continued)

One workaround is to tie DCDC1\_EN to VINDCDC1 (Figure 39).

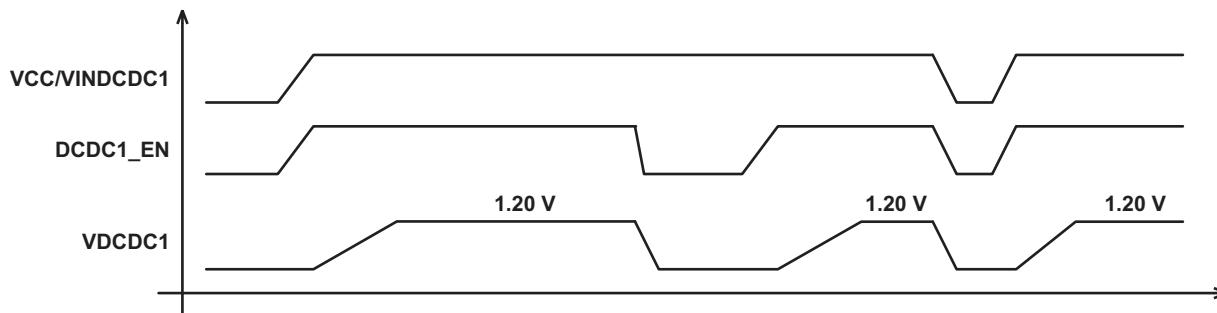


Figure 39. Workaround 1

Another workaround is to write the correct voltage to the DEF\_CORE register through I<sup>2</sup>C. This can be done before or after the converter is enabled. If written before the enable, the only bit changed is DEF\_CORE[0]. The voltage is 1.2 V, however, when the enable is pulled high (Figure 40).

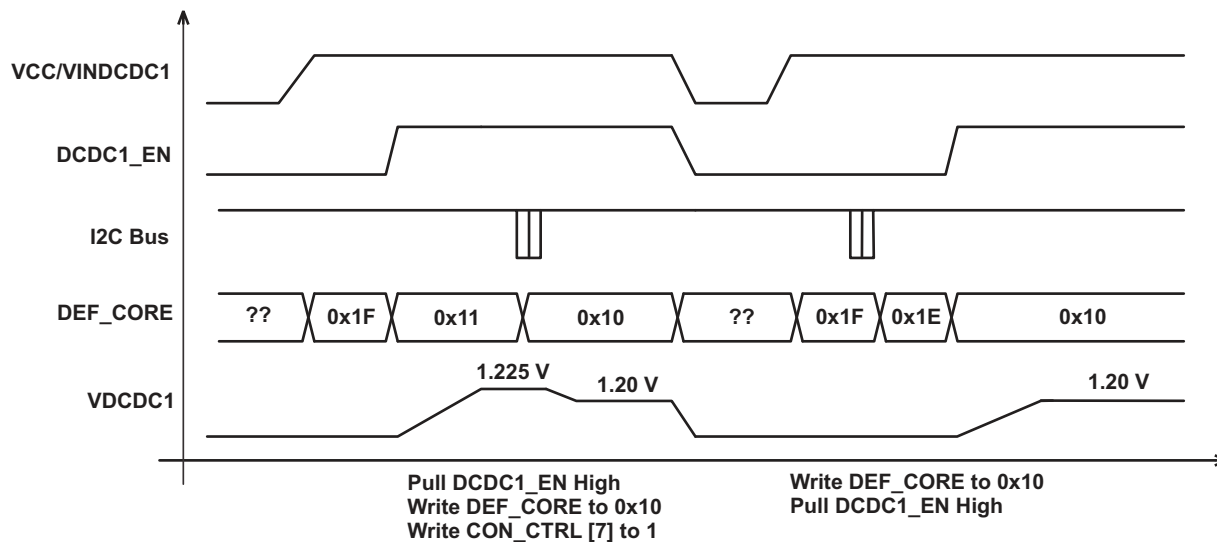


Figure 40. Workaround 2

A third workaround is to generate a  $\overline{\text{HOT\_RESET}}$  after enabling DCDC1 (Figure 41).

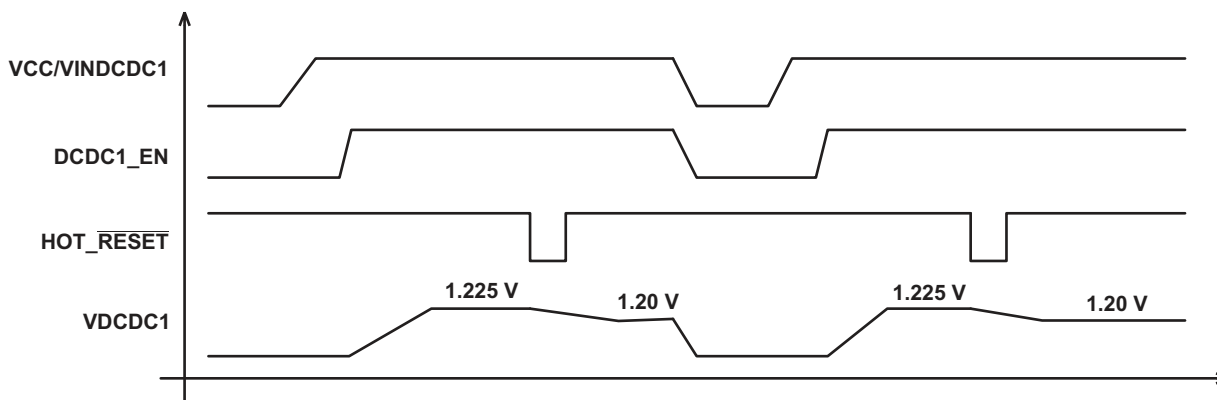


Figure 41. Workaround 3

Application Information (continued)

Table 17. Differences of TPS650231 vs TPS65023 and TPS65023B

ITEM	DESCRIPTION	TPS65023	TPS65023B	TPS650231
V <sub>IH</sub>	High level input voltage for the SDAT pin	Minimum 1.3 V	Minimum 1.65 V; V <sub>CC</sub> = 2.5 V to 5.25 V	Minimum 1.65 V; V <sub>CC</sub> = 2.5 V to 5.25 V
V <sub>IH</sub>	High level input voltage for the SCLK pin	Minimum 1.3 V	Minimum 1.4 V, V <sub>CC</sub> = 2.5 V to 5.25 V	Minimum 1.4 V, V <sub>CC</sub> = 2.5 V to 5.25 V
V <sub>IL</sub>	Low level input voltage for SCLK and SDAT pin	Maximum 0.4 V	Maximum 0.35 V	Maximum 0.35 V
t <sub>h</sub> (DATA)	Data input hold time	Minimum 300 ns	Minimum 100 ns	Minimum 100 ns
t <sub>su</sub> (DATA)	Data input setup time	Minimum 300 ns	Minimum 100 ns	Minimum 100 ns
	LDO1 voltage for setting LDO1_[2..0] = 011	1.8 V	1.8 V	2.1 V
	DEFDCDC2 pin functionality	1) DEFDCDC2 = LOW: V <sub>o</sub> = 1.8 V 2) DEFDCDC2 = HIGH: V <sub>o</sub> = 3.3 V 3) 0.6 V feedback input	1) DEFDCDC2 = LOW: V <sub>o</sub> = 1.8 V 2) DEFDCDC2 = HIGH: V <sub>o</sub> = 3.3 V 3) 0.6 V feedback input	0.6 V feedback input only (allows voltage scaling with external resistor divider without restrictions)

9.2 Typical Application

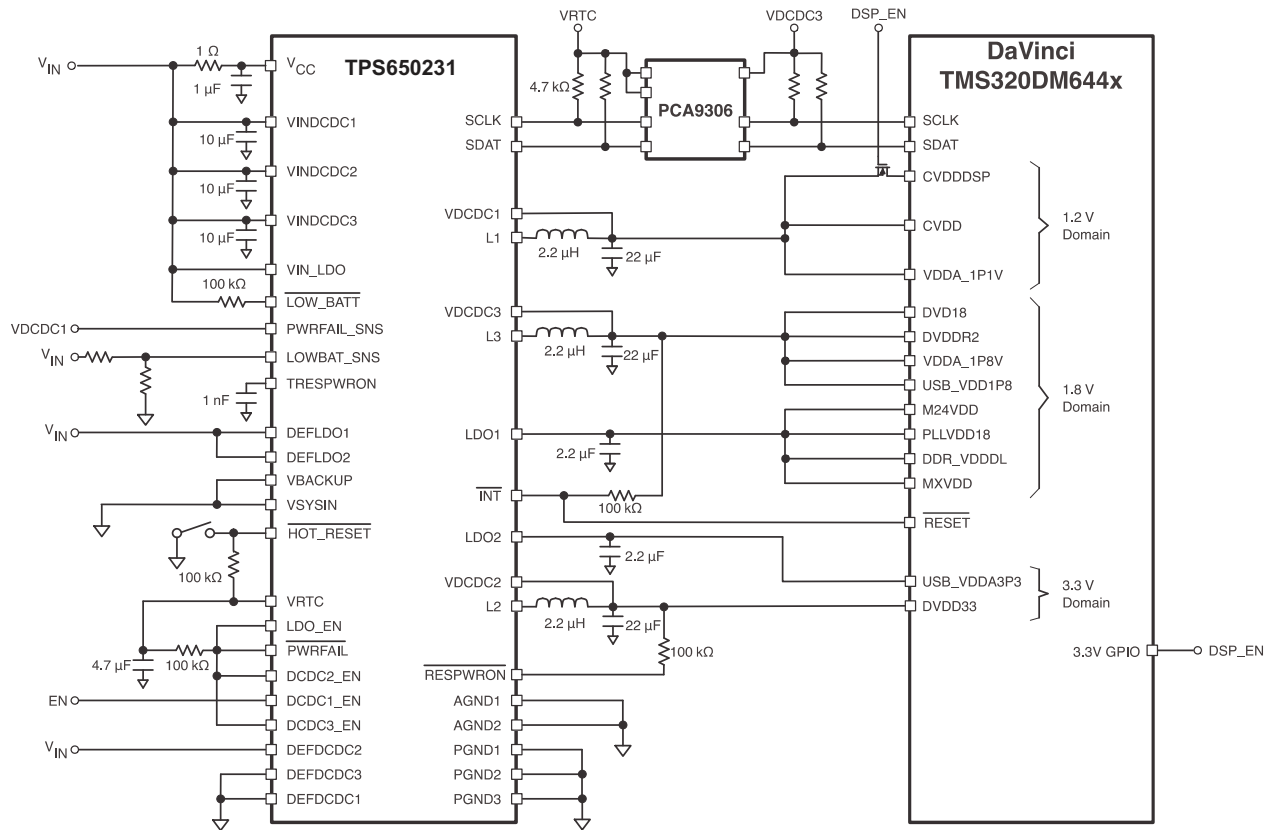


Figure 42. Typical Configuration for the Texas Instruments TMS320DM644x DaVinci Processors



## Typical Application (continued)

### 9.2.1 Design Requirements

The TPS650231 device has only a few design requirements. Use the following parameters for the design examples:

- 1-μF bypass capacitor on VCC, located as close as possible to the VCC pin to ground
- VCC and VINDCDCx must be connected to the same voltage supply with minimal voltage difference
- Input capacitors must be present on the VINDCDCx and VIN\_LDO supplies if used
- Output inductor and capacitors must be used on the outputs of the DCDC converters if used
- Output capacitors must be used on the outputs of the LDOs if used

### 9.2.2 Detailed Design Procedure

#### 9.2.2.1 Inductor Selection for the DC-DC Converters

Each of the converters in the TPS650231 typically use a 2.2-μH output inductor. Larger or smaller inductor values are used to optimize the performance of the device for specific operation conditions. The selected inductor has to be rated for its DC resistance and saturation current. The DC resistance of the inductance influences directly the efficiency of the converter. Therefore, an inductor with lowest DC resistance must be selected for highest efficiency.

For a fast transient response, a 2.2-μH inductor in combination with a 22-μF output capacitor is recommended.

[Equation 8](#) calculates the maximum inductor current under static load conditions. The saturation current of the inductor must be rated higher than the maximum inductor current as calculated with [Equation 8](#). This is needed because during heavy-load transient the inductor current rises above the value calculated under [Equation 8](#).

$$\Delta I_L = V_{out} \times \frac{1 - \frac{V_{out}}{V_{in}}}{L \times f} \quad (8)$$

$$I_{Lmax} = I_{outmax} + \frac{\Delta I_L}{2}$$

where

- f = Switching frequency (2.25 MHz typical)
- L = Inductor value
- $\Delta I_L$  = Peak-to-peak inductor ripple current
- $I_{LMAX}$  = Maximum inductor current

The highest inductor current occurs at maximum Vin.

Open-core inductors have a soft saturation characteristic, and they can usually handle higher inductor currents versus a comparable shielded inductor.

A more conservative approach is to select the inductor current rating just for the maximum switch current of the TPS650231 (2 A for the VDCDC1 and VDCDC2 converters, and 1.5 A for the VDCDC3 converter). The core material from inductor to inductor differs and has an impact on the efficiency especially at high switching frequencies.

See [Table 18](#) and the typical applications for possible inductors.

**Table 18. Tested Inductors**

DEVICE	INDUCTOR VALUE	TYPE	COMPONENT SUPPLIER
All Converters	2.2 μH	LPS4012-222LMB	Coilcraft
	2.2 μH	VLCF4020T-2R2N1R7	TDK
For DCDC2 or DCDC3	2.2 μH	LQH32PN2R2NN0	Murata
	2.2 μH	PSI25201T-2R2	Cyntec
For DCDC1	1.5 μH	LQH32PN1R5NN0	Murata

### 9.2.2.2 Output Capacitor Selection

The advanced fast response voltage mode control scheme of the inductive converters implemented in the TPS650231 allow the use of small ceramic capacitors with a typical value of 10  $\mu\text{F}$  for each converter without having large output voltage under and overshoots during heavy load transients. Ceramic capacitors with low ESR values have the lowest output voltage ripple and are recommended. See [Table 19](#) for recommended components.

If ceramic output capacitors are used, the capacitor RMS ripple current rating always meets the application requirements. Just for completeness, the RMS ripple current is calculated with [Equation 10](#).

$$I_{\text{RMS}C_{\text{out}}} = V_{\text{out}} \times \frac{1 - \frac{V_{\text{out}}}{V_{\text{in}}}}{L \times f} \times \frac{1}{2 \times \sqrt{3}} \quad (10)$$

At nominal load current, the inductive converters operate in PWM mode. The overall output voltage ripple is the sum of the voltage spike caused by the output capacitor ESR plus the voltage ripple caused by charging and discharging the output capacitor in [Equation 11](#).

$$\Delta V_{\text{out}} = V_{\text{out}} \times \frac{1 - \frac{V_{\text{out}}}{V_{\text{in}}}}{L \times f} \times \left( \frac{1}{8 \times C_{\text{out}} \times f} + \text{ESR} \right)$$

where

- the highest output voltage ripple occurs at the highest input voltage  $V_{\text{in}}$  (11)

At light-load currents, the converters operate in PSM and the output voltage ripple is dependent on the output capacitor value. The output voltage ripple is set by the internal comparator delay and the external capacitor. The typical output voltage ripple is less than 1% of the nominal output voltage.

### 9.2.2.3 Input Capacitor Selection

Because of the nature of the buck converter having a pulsating input current, a low-ESR input capacitor is required for best input voltage filtering and minimizing the interference with other circuits caused by high input voltage spikes. Each DC-DC converter requires a 10- $\mu\text{F}$  ceramic input capacitor on its input pin  $V_{\text{IND}C_{\text{DC}x}}$ . The input capacitor is increased without any limit for better input voltage filtering. The VCC pin is separated from the input for the DC-DC converters. A filter resistor of up to 10R and a 1- $\mu\text{F}$  capacitor is used for decoupling the VCC pin from switching noise.

#### NOTE

The filter resistor may affect the UVLO threshold because up to 3 mA can flow through this resistor into the VCC pin when all converters are running in PWM mode.

**Table 19. Possible Capacitors**

CAPACITOR VALUE	CASE SIZE	COMPONENT SUPPLIER	COMMENTS
22 $\mu\text{F}$	0805	TDK C2012X5R0J226MT	Ceramic
22 $\mu\text{F}$	0805	Taiyo Yuden JMK212BJ226MG	Ceramic
10 $\mu\text{F}$	0805	Taiyo Yuden JMK212BJ106M	Ceramic
10 $\mu\text{F}$	0805	TDK C2012X5R0J106M	Ceramic
10 $\mu\text{F}$	0603	Taiyo Yuden JMK107BJ106	Ceramic

### 9.2.2.4 Output Voltage Selection

The DEFDCDC1, DEFDCDC2, and DEFDCDC3 pins are used to set the output voltage for each step-down converter. For DEFDCDC1 and DEFDCDC3 there are default voltages defined when the pin is tied to a logic low or logic high signal. See [Table 20](#) for the default voltages if the pins are pulled to GND or to  $V_{\text{CC}}$ . If a different voltage is needed, an external resistor divider can be added to the DEFDCDCx pin as shown in [Figure 43](#).

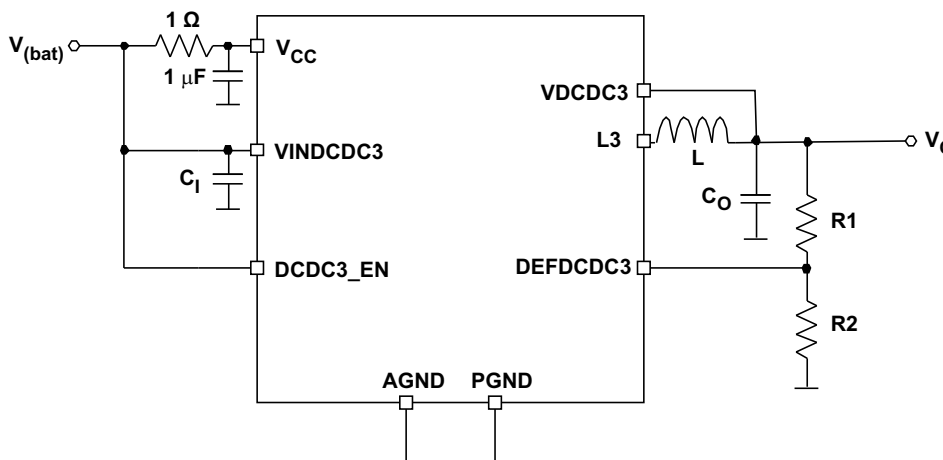
The output voltage of VDCDC1 is set with the I<sup>2</sup>C interface. If the voltage is changed from the default, using the DEFDCORE register, the output voltage only depends on the register value. Any resistor divider at DEFDCDC1 can not change the voltage set with the register. TI does not recommend changing the divider ratio of a resistor divider connected at DEFDCDC1 or DEFDCDC3 during operation as the internal logic may detect a logic high signal in error during the change from a high voltage to a lower voltage and scales the output to the voltage defined by DEFDCDCx = HIGH. As DEFDCDC2 does not have these default fixed voltages, the resistor divider can be changed during operation.

**Table 20. DCDC1 and DCDC3 Default Voltage Levels**

PIN	LEVEL	DEFAULT OUTPUT VOLTAGE
DEFDCDC1	VCC	1.6 V
	GND	1.2 V
DEFDCDC3	VCC	3.3 V
	GND	1.8 V

This function is not available on the DCDC2 converter. DEFDCDC2 always needs to be connected to a resistive divider.

Using an external resistor divider for the DEFDCDCx is shown in Figure 43.



**Figure 43. External Resistor Divider**

When a resistor divider is connected to DEFDCDCx, the output voltage can be set from 0.6 V up to the input voltage V<sub>(bat)</sub>. The total resistance (R1+R2) of the voltage divider must be kept in the 1-MΩ range to maintain a high efficiency at light load.

$$V_{(DEFDCDCx)} = 0.6 \text{ V}$$

$$V_{OUT} = V_{DEFDCDCx} \times \frac{R1 + R2}{R2} \quad R1 = R2 \times \left( \frac{V_{OUT}}{V_{DEFDCDCx}} \right) - R2 \quad (12)$$

### 9.2.2.5 VRTC Output

It is required to add a capacitor of 4.7-μF minimum to the VRTC pin, even the output may be unused.

### 9.2.2.6 LDO1 and LDO2

The LDOs in the TPS650231 are general-purpose LDOs which are stable using ceramics capacitors. The minimum output capacitor required is 2.2 μF. The LDOs output voltage can be changed to different voltages between 1 V and 3.3 V using the I<sup>2</sup>C interface. The supply voltage for the LDOs needs to be connected to the VINLDO pin, giving the flexibility to connect the lowest voltage available in the system and provides the highest efficiency.

### 9.2.2.7 TRESPWRON

This is the input to a capacitor that defines the reset delay time after the voltage at VRTC rises above 2.52 V. The timing is generated by charging and discharging the capacitor with a current of 2 μA between a threshold of 0.25 V and 1 V for 128 cycles. A 1-nF capacitor gives a delay time of 100 ms.

While there is no real upper and lower limit for the capacitor connected to TRESPWRON, TI recommends to not leave signal pins open.

$$t_{(\text{reset})} = 2 \times 128 \times \left( \frac{(1 \text{ V} - 0.25 \text{ V}) \times C_{(\text{reset})}}{2 \mu\text{A}} \right)$$

where

- $t_{(\text{reset})}$  is the reset delay time
- $C_{(\text{reset})}$  is the capacitor connected to the TRESPWRON pin (13)

The minimum and maximum values for the timing parameters called ICONST (2 μA), TRESPWRON\_UTH (1 V) and TRESPWRON\_LWTH (0.25 V) can be found in [Specifications](#).

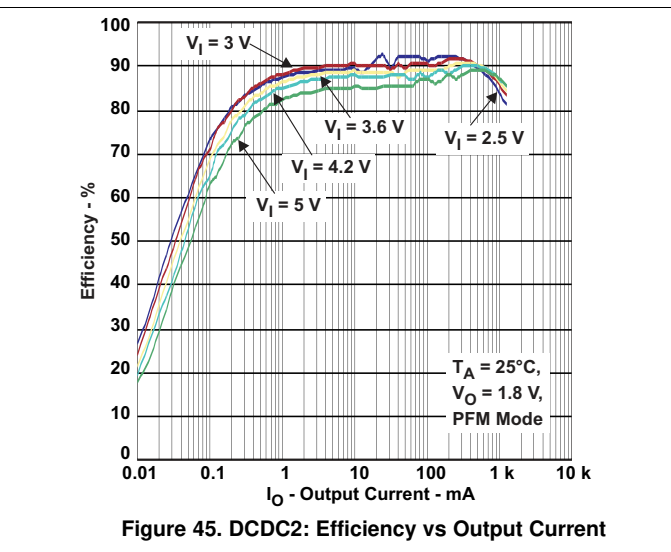
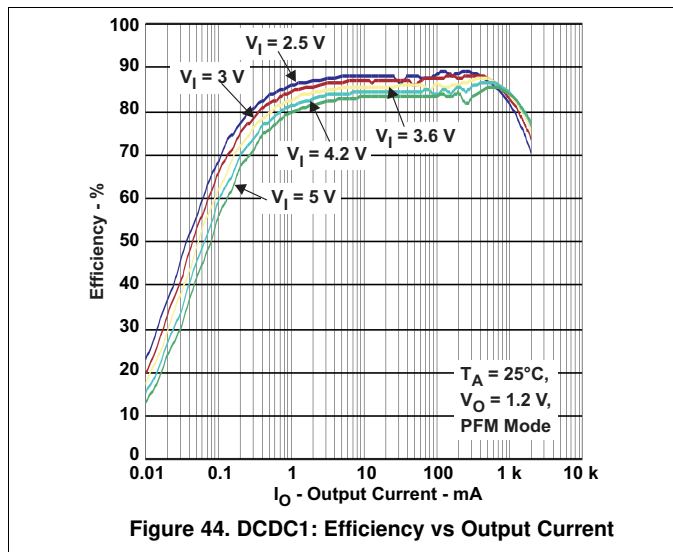
### 9.2.2.8 V<sub>CC</sub> Filter

An RC filter connected at the VCC input is used to keep noise from the internal supply for the bandgap and other analog circuitry. A typical value of 1 Ω and 1 μF is used to filter the switching spikes, generated by the DC-DC converters. A larger resistor than 10 Ω must not be used because the current into VCC of up to 3 mA causes a voltage drop at the resistor causing the undervoltage lockout circuitry connected at VCC internally to switch off too early.

### 9.2.3 Application Curves

Graphs were taken using the EVM with the following inductor and output capacitor combinations:

CONVERTER	INDUCTOR	OUTPUT CAPACITOR	OUTPUT CAPACITOR VALUE
VDCDC1	LQH32PN1R5	JMK107BJ106	2 × 10 μF
VDCDC2	LQH32PN2R2	JMK107BJ106	2 × 10 μF
VDCDC3	LQH32PN2R2	JMK107BJ106	2 × 10 μF



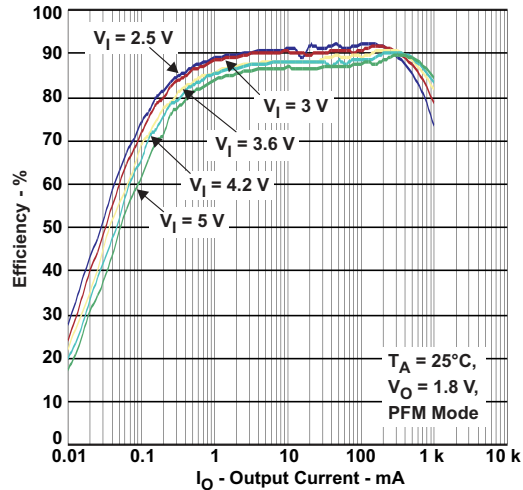


Figure 46. DCDC3: Efficiency vs Output Current

## 10 Power Supply Recommendations

### 10.1 Requirements for Supply Voltages Below 3.0 V

For a supply voltage on pins VCC, VINDCDC1, VINDCDC2, and VINDCDC3 below 3.0 V, TI recommends enabling the DCDC1, DCDC2, and DCDC3 converters in sequence. If all 3 step-down converters are enabled at the same time while the supply voltage is close to the internal reset detection threshold, a reset may be generated during power-up. Therefore, TI recommends enabling the DC-DC converters in sequence. This can be done by driving one or two of the enable pins with a RC delay or by driving the enable pin by the output voltage of one of the other step-down converters. If a voltage above 3.0 V is applied on pin VBACKUP while VCC and VINDCDCx is below 3.0 V, there is no restriction in the power-up sequencing as VBACKUP is used to power the internal circuitry.

## 11 Layout

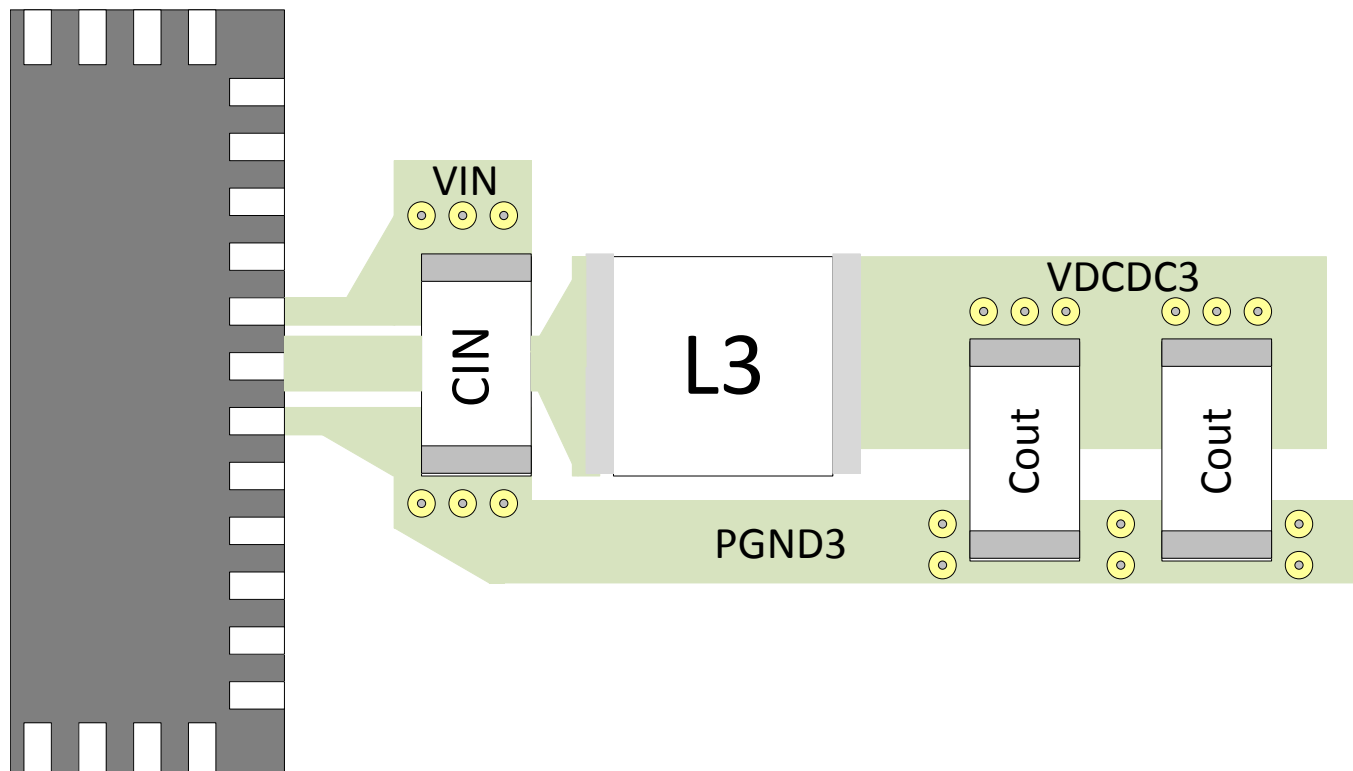
### 11.1 Layout Guidelines

As for all switching power supplies, the layout is an important step in the design. Proper function of the device demands careful attention to PCB layout. Take care in board layout to get the specified performance. If the layout is not carefully done, the regulators may show poor line and/or load regulation, and stability issues, as well as EMI problems. It is critical to provide a low impedance ground path. Therefore, use wide and short traces for the main current paths. The input capacitors must be placed as close as possible to the IC pins as well as the inductor and output capacitor.

For TPS650231RSB, connect the PGND pins of the device to the PowerPAD land of the PCB and connect the analog ground connections (AGND) to the PGND at the PowerPAD. It is essential to provide a good thermal and electrical connection of all GND pins using multiples through to the GND-plane. Keep the common path to the AGND pins, which returns the small signal components, and the high current of the output capacitors as short as possible to avoid ground noise. The VDCDCx line must be connected right to the output capacitor and routed away from noisy components and traces (for example, the L1, L2, and L3 traces).

For TPS650231YFF, connect the PGND pins of the device and the analog ground connections (AGND) to the GND plane on the board. It is essential to provide a good thermal and electrical connection of all GND pins to the GND-plane. Keep the common path to the AGND pins, which returns the small signal components, and the high current of the output capacitors as short as possible to avoid ground noise. The VDCDCx line must be connected right to the output capacitor and routed away from noisy components and traces (for example, the L1, L2, and L3 traces).

### 11.2 Layout Example



**Figure 47. DC-DC Regulator Layout Example**

## 12 Device and Documentation Support

### 12.1 Device Support

#### 12.1.1 Third-Party Products Disclaimer

TI'S PUBLICATION OF INFORMATION REGARDING THIRD-PARTY PRODUCTS OR SERVICES DOES NOT CONSTITUTE AN ENDORSEMENT REGARDING THE SUITABILITY OF SUCH PRODUCTS OR SERVICES OR A WARRANTY, REPRESENTATION OR ENDORSEMENT OF SUCH PRODUCTS OR SERVICES, EITHER ALONE OR IN COMBINATION WITH ANY TI PRODUCT OR SERVICE.

### 12.2 Community Resources

The following links connect to TI community resources. Linked contents are provided "AS IS" by the respective contributors. They do not constitute TI specifications and do not necessarily reflect TI's views; see TI's [Terms of Use](#).

**TI E2E™ Online Community** *TI's Engineer-to-Engineer (E2E) Community*. Created to foster collaboration among engineers. At [e2e.ti.com](http://e2e.ti.com), you can ask questions, share knowledge, explore ideas and help solve problems with fellow engineers.

**Design Support** *TI's Design Support* Quickly find helpful E2E forums along with design support tools and contact information for technical support.

### 12.3 Trademarks

PowerPAD, E2E are trademarks of Texas Instruments.  
I<sup>2</sup>C is a trademark of NXP Semiconductors.  
All other trademarks are the property of their respective owners.

### 12.4 Electrostatic Discharge Caution



These devices have limited built-in ESD protection. The leads should be shorted together or the device placed in conductive foam during storage or handling to prevent electrostatic damage to the MOS gates.

### 12.5 Glossary

[SLYZ022](#) — *TI Glossary*.

This glossary lists and explains terms, acronyms, and definitions.

## 13 Mechanical, Packaging, and Orderable Information

The following pages include mechanical, packaging, and orderable information. This information is the most current data available for the designated devices. This data is subject to change without notice and revision of this document. For browser-based versions of this data sheet, refer to the left-hand navigation.

**PACKAGING INFORMATION**

Orderable Device	Status (1)	Package Type	Package Drawing	Pins	Package Qty	Eco Plan (2)	Lead finish/ Ball material (6)	MSL Peak Temp (3)	Op Temp (°C)	Device Marking (4/5)	Samples
TPS650231RSBR	ACTIVE	WQFN	RSB	40	3000	RoHS & Green	NIPDAU	Level-2-260C-1 YEAR	-40 to 85	TPS 650231	<a href="#">Samples</a>
TPS650231RSBT	ACTIVE	WQFN	RSB	40	250	RoHS & Green	NIPDAU	Level-2-260C-1 YEAR	-40 to 85	TPS 650231	<a href="#">Samples</a>
TPS650231YFFR	ACTIVE	DSBGA	YFF	49	3000	RoHS & Green	SNAGCU	Level-1-260C-UNLIM	-40 to 85	TPS650231	<a href="#">Samples</a>
TPS650231YFFT	ACTIVE	DSBGA	YFF	49	250	RoHS & Green	SNAGCU	Level-1-260C-UNLIM	-40 to 85	TPS650231	<a href="#">Samples</a>

(1) The marketing status values are defined as follows:

**ACTIVE:** Product device recommended for new designs.

**LIFEBUY:** TI has announced that the device will be discontinued, and a lifetime-buy period is in effect.

**NRND:** Not recommended for new designs. Device is in production to support existing customers, but TI does not recommend using this part in a new design.

**PREVIEW:** Device has been announced but is not in production. Samples may or may not be available.

**OBSELETE:** TI has discontinued the production of the device.

(2) **RoHS:** TI defines "RoHS" to mean semiconductor products that are compliant with the current EU RoHS requirements for all 10 RoHS substances, including the requirement that RoHS substance do not exceed 0.1% by weight in homogeneous materials. Where designed to be soldered at high temperatures, "RoHS" products are suitable for use in specified lead-free processes. TI may reference these types of products as "Pb-Free".

**RoHS Exempt:** TI defines "RoHS Exempt" to mean products that contain lead but are compliant with EU RoHS pursuant to a specific EU RoHS exemption.

**Green:** TI defines "Green" to mean the content of Chlorine (Cl) and Bromine (Br) based flame retardants meet JS709B low halogen requirements of <=1000ppm threshold. Antimony trioxide based flame retardants must also meet the <=1000ppm threshold requirement.

(3) MSL, Peak Temp. - The Moisture Sensitivity Level rating according to the JEDEC industry standard classifications, and peak solder temperature.

(4) There may be additional marking, which relates to the logo, the lot trace code information, or the environmental category on the device.

(5) Multiple Device Markings will be inside parentheses. Only one Device Marking contained in parentheses and separated by a "-" will appear on a device. If a line is indented then it is a continuation of the previous line and the two combined represent the entire Device Marking for that device.

(6) Lead finish/Ball material - Orderable Devices may have multiple material finish options. Finish options are separated by a vertical ruled line. Lead finish/Ball material values may wrap to two lines if the finish value exceeds the maximum column width.

**Important Information and Disclaimer:**The information provided on this page represents TI's knowledge and belief as of the date that it is provided. TI bases its knowledge and belief on information provided by third parties, and makes no representation or warranty as to the accuracy of such information. Efforts are underway to better integrate information from third parties. TI has taken and



continues to take reasonable steps to provide representative and accurate information but may not have conducted destructive testing or chemical analysis on incoming materials and chemicals. TI and TI suppliers consider certain information to be proprietary, and thus CAS numbers and other limited information may not be available for release.

In no event shall TI's liability arising out of such information exceed the total purchase price of the TI part(s) at issue in this document sold by TI to Customer on an annual basis.

**TAPE AND REEL INFORMATION**

**QUADRANT ASSIGNMENTS FOR PIN 1 ORIENTATION IN TAPE**


\*All dimensions are nominal

Device	Package Type	Package Drawing	Pins	SPQ	Reel Diameter (mm)	Reel Width W1 (mm)	A0 (mm)	B0 (mm)	K0 (mm)	P1 (mm)	W (mm)	Pin1 Quadrant
TPS650231RSBR	WQFN	RSB	40	3000	330.0	12.4	5.3	5.3	1.1	8.0	12.0	Q2
TPS650231RSBT	WQFN	RSB	40	250	180.0	12.4	5.3	5.3	1.1	8.0	12.0	Q2
TPS650231YFFR	DSBGA	YFF	49	3000	180.0	8.4	3.16	3.16	0.71	4.0	8.0	Q1
TPS650231YFFT	DSBGA	YFF	49	250	180.0	8.4	3.16	3.16	0.71	4.0	8.0	Q1

**TAPE AND REEL BOX DIMENSIONS**

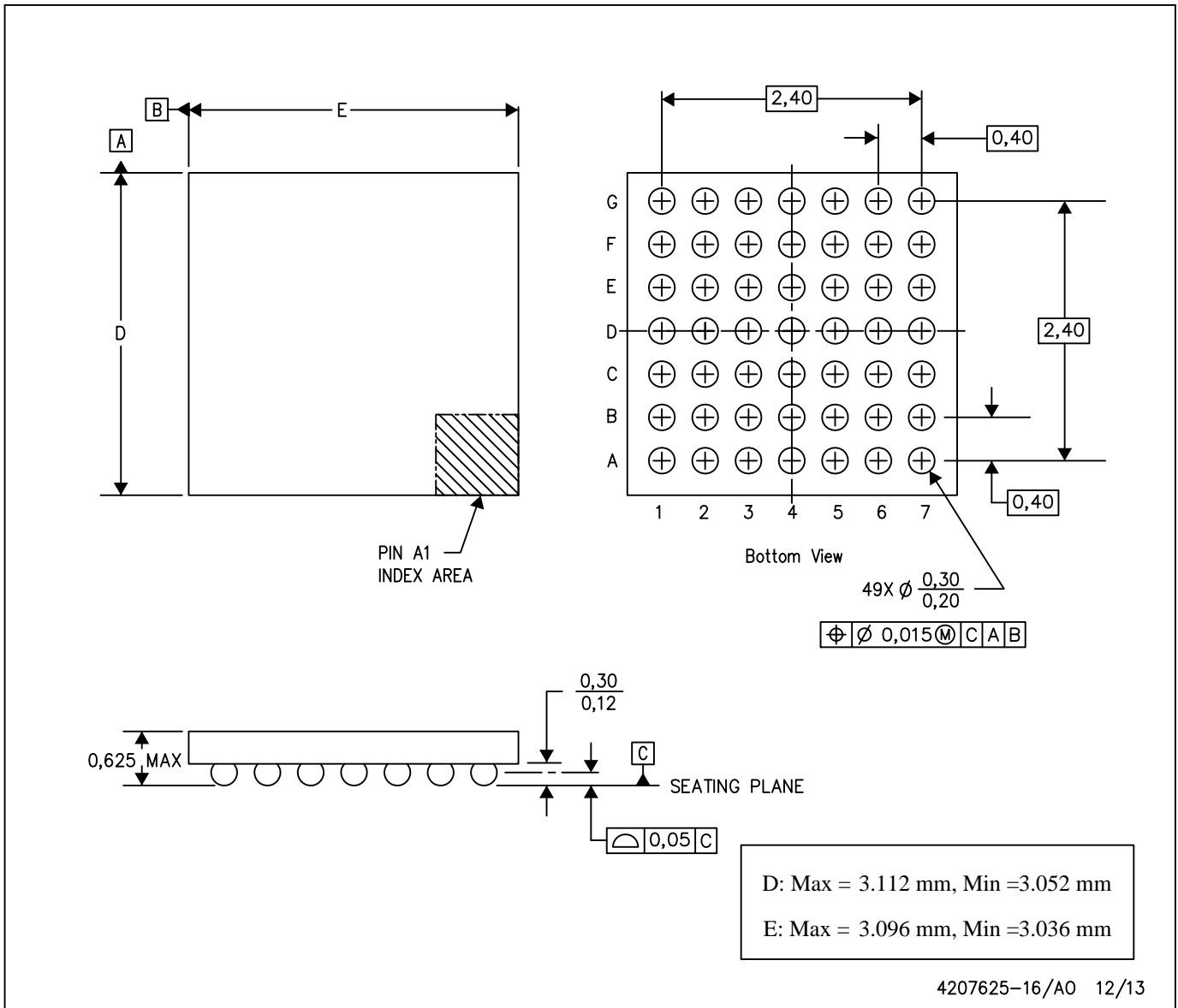

\*All dimensions are nominal

Device	Package Type	Package Drawing	Pins	SPQ	Length (mm)	Width (mm)	Height (mm)
TPS650231RSBR	WQFN	RSB	40	3000	346.0	346.0	33.0
TPS650231RSBT	WQFN	RSB	40	250	210.0	185.0	35.0
TPS650231YFFR	DSBGA	YFF	49	3000	182.0	182.0	20.0
TPS650231YFFT	DSBGA	YFF	49	250	182.0	182.0	20.0

**MECHANICAL DATA**

YFF (R-XBGA-N49)

DIE-SIZE BALL GRID ARRAY



- NOTES: A. All linear dimensions are in millimeters. Dimensioning and tolerancing per ASME Y14.5M-1994.  
 B. This drawing is subject to change without notice.  
 C. NanoFree™ package configuration.

NanoFree is a trademark of Texas Instruments.

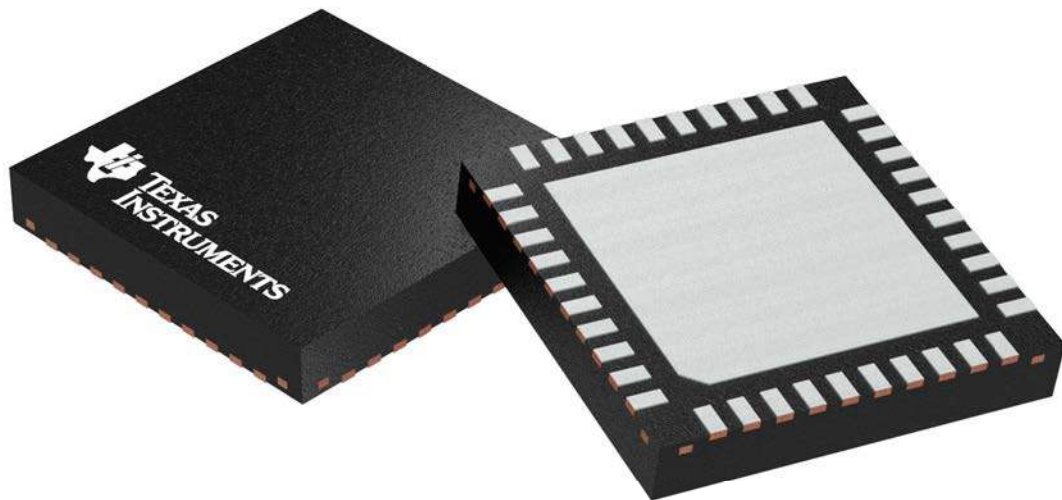
## GENERIC PACKAGE VIEW

**RSB 40**

**WQFN - 0.8 mm max height**

5 x 5 mm, 0.4 mm pitch

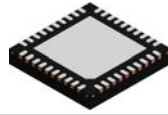
PLASTIC QUAD FLATPACK - NO LEAD



Images above are just a representation of the package family, actual package may vary.  
Refer to the product data sheet for package details.

4207182/D

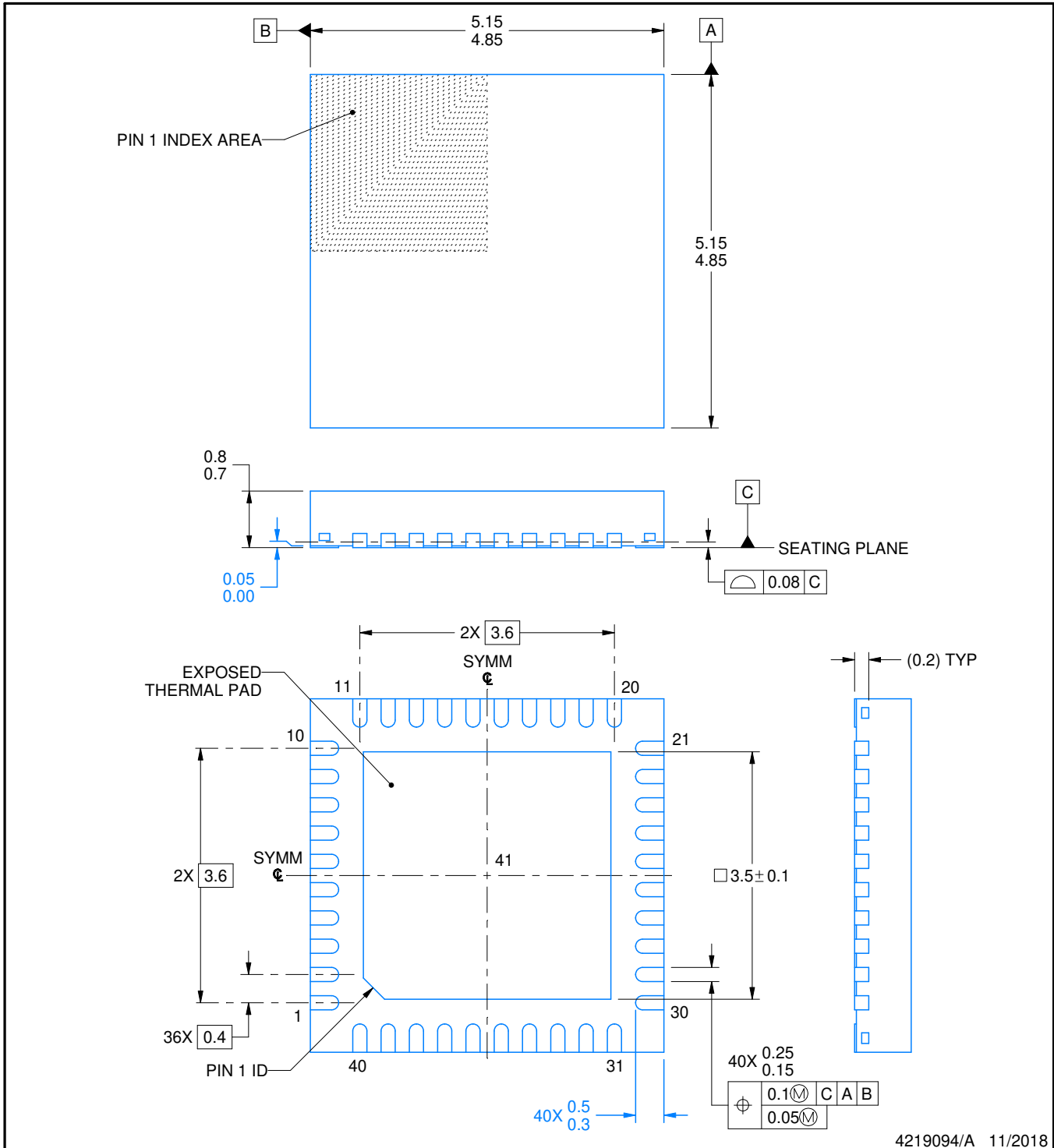
# RSB0040B



# PACKAGE OUTLINE

## WQFN - 0.8 mm max height

PLASTIC QUAD FLATPACK - NO LEAD



4219094/A 11/2018

### NOTES:

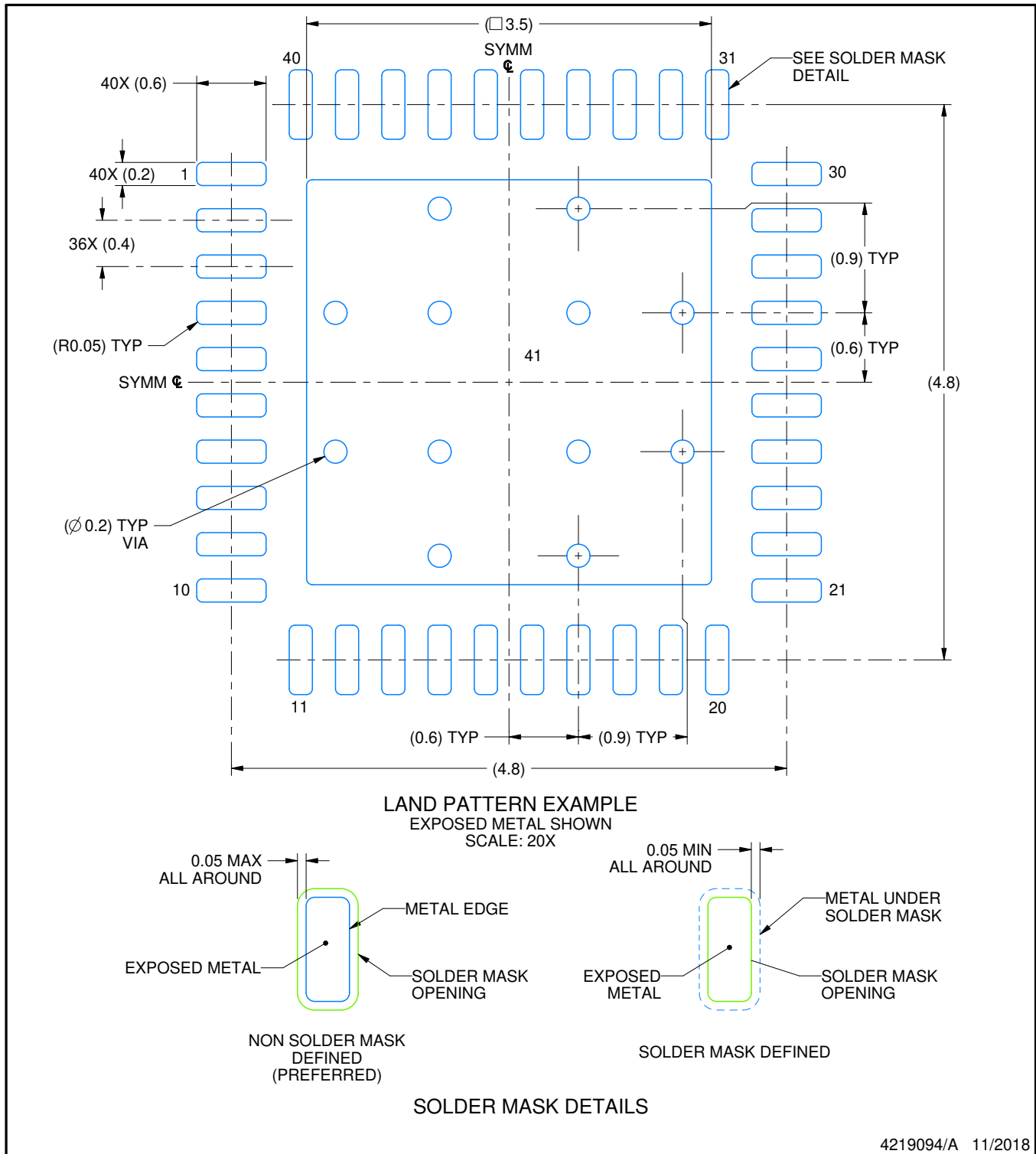
1. All linear dimensions are in millimeters. Any dimensions in parenthesis are for reference only. Dimensioning and tolerancing per ASME Y14.5M.
2. This drawing is subject to change without notice.
3. The package thermal pad must be soldered to the printed circuit board for thermal and mechanical performance.

# EXAMPLE BOARD LAYOUT

RSB0040B

WQFN - 0.8 mm max height

PLASTIC QUAD FLATPACK - NO LEAD



4219094/A 11/2018

NOTES: (continued)

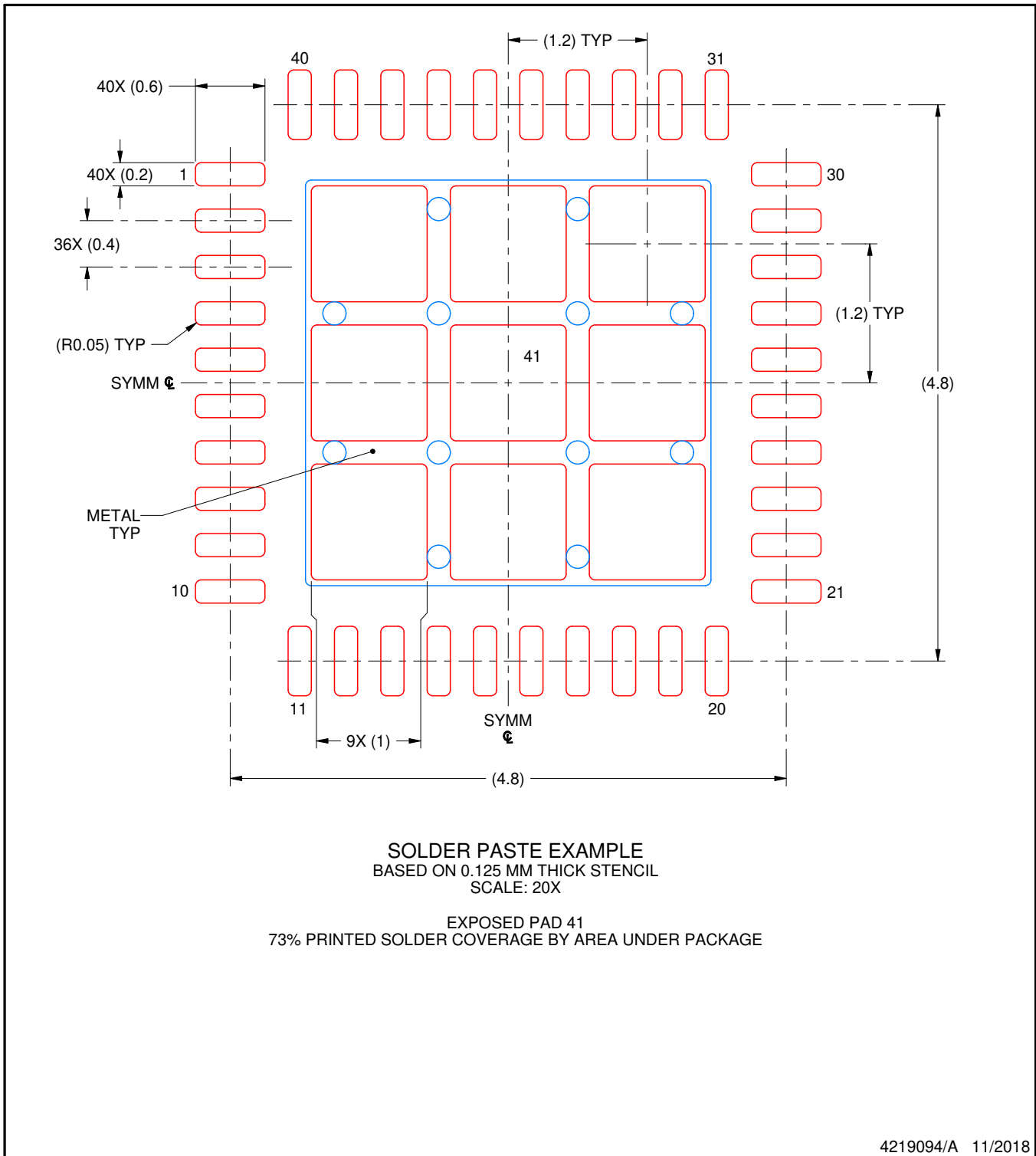
4. This package is designed to be soldered to a thermal pad on the board. For more information, see Texas Instruments literature number SLUA271 ([www.ti.com/lit/slue271](http://www.ti.com/lit/slue271)).
5. Vias are optional depending on application, refer to device data sheet. If any vias are implemented, refer to their locations shown on this view. It is recommended that vias under paste be filled, plugged or tented.

# EXAMPLE STENCIL DESIGN

RSB0040B

WQFN - 0.8 mm max height

PLASTIC QUAD FLATPACK - NO LEAD



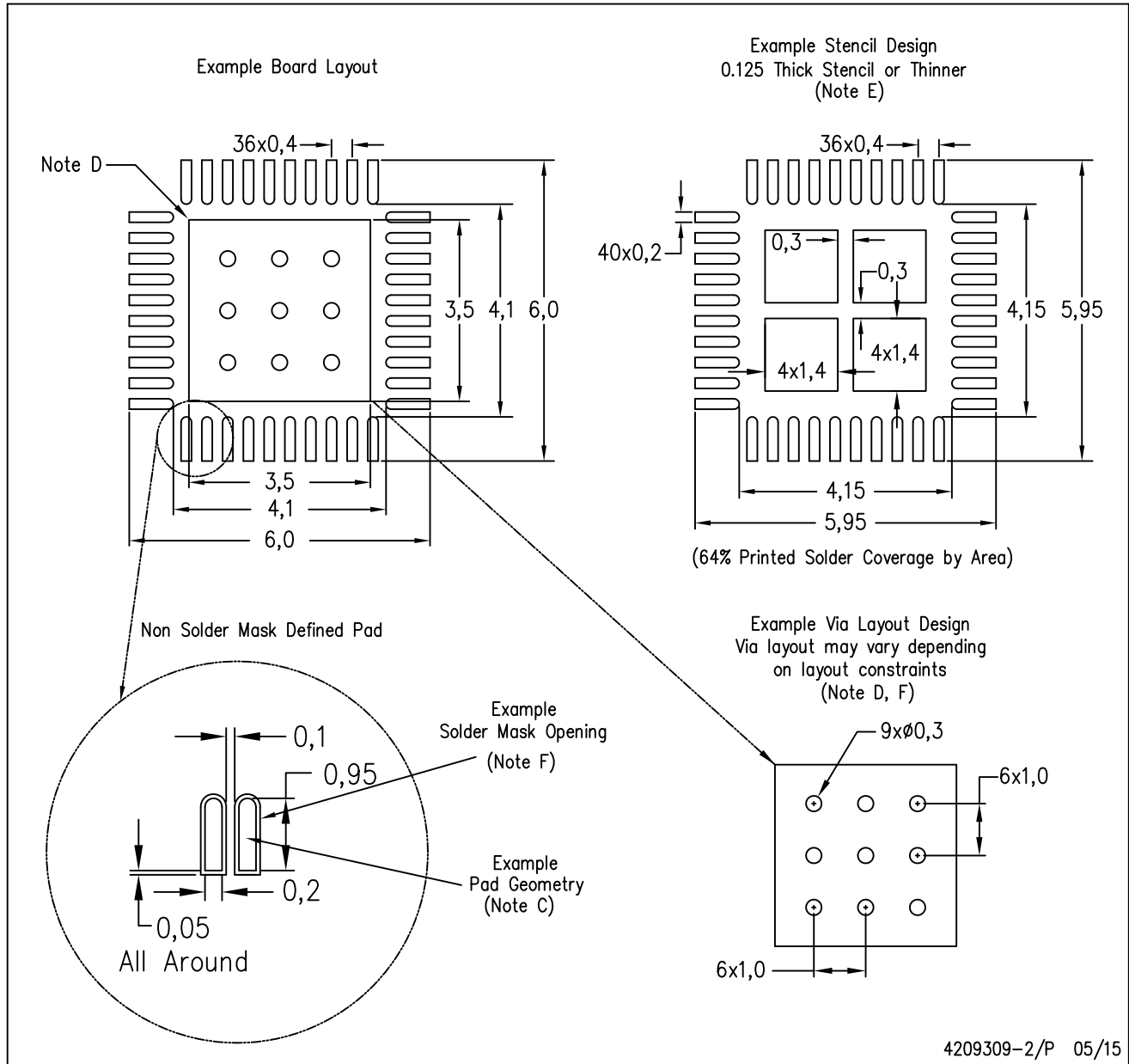
NOTES: (continued)

6. Laser cutting apertures with trapezoidal walls and rounded corners may offer better paste release. IPC-7525 may have alternate design recommendations.



RSB (S-PWQFN-N40)

PLASTIC QUAD FLATPACK NO-LEAD



- NOTES:
- All linear dimensions are in millimeters.
  - This drawing is subject to change without notice.
  - Publication IPC-7351 is recommended for alternate designs.
  - This package is designed to be soldered to a thermal pad on the board. Refer to Application Note, Quad Flat-Pack Packages, Texas Instruments Literature No. SLUA271, and also the Product Data Sheets for specific thermal information, via requirements, and recommended board layout. These documents are available at [www.ti.com](http://www.ti.com) <<http://www.ti.com>>.
  - Laser cutting apertures with trapezoidal walls and also rounding corners will offer better paste release. Customers should contact their board assembly site for stencil design recommendations. Refer to IPC 7525 for stencil design considerations.
  - Customers should contact their board fabrication site for recommended solder mask tolerances and via tenting recommendations for vias placed in the thermal pad.

## IMPORTANT NOTICE AND DISCLAIMER

TI PROVIDES TECHNICAL AND RELIABILITY DATA (INCLUDING DATA SHEETS), DESIGN RESOURCES (INCLUDING REFERENCE DESIGNS), APPLICATION OR OTHER DESIGN ADVICE, WEB TOOLS, SAFETY INFORMATION, AND OTHER RESOURCES "AS IS" AND WITH ALL FAULTS, AND DISCLAIMS ALL WARRANTIES, EXPRESS AND IMPLIED, INCLUDING WITHOUT LIMITATION ANY IMPLIED WARRANTIES OF MERCHANTABILITY, FITNESS FOR A PARTICULAR PURPOSE OR NON-INFRINGEMENT OF THIRD PARTY INTELLECTUAL PROPERTY RIGHTS.

These resources are intended for skilled developers designing with TI products. You are solely responsible for (1) selecting the appropriate TI products for your application, (2) designing, validating and testing your application, and (3) ensuring your application meets applicable standards, and any other safety, security, regulatory or other requirements.

These resources are subject to change without notice. TI grants you permission to use these resources only for development of an application that uses the TI products described in the resource. Other reproduction and display of these resources is prohibited. No license is granted to any other TI intellectual property right or to any third party intellectual property right. TI disclaims responsibility for, and you will fully indemnify TI and its representatives against, any claims, damages, costs, losses, and liabilities arising out of your use of these resources.

TI's products are provided subject to [TI's Terms of Sale](#) or other applicable terms available either on [ti.com](https://www.ti.com) or provided in conjunction with such TI products. TI's provision of these resources does not expand or otherwise alter TI's applicable warranties or warranty disclaimers for TI products.

TI objects to and rejects any additional or different terms you may have proposed.

Mailing Address: Texas Instruments, Post Office Box 655303, Dallas, Texas 75265  
Copyright © 2023, Texas Instruments Incorporated