

ECS-TXO53-S3 CMOS SMD TCXO/VCTCXO. The 5.0 x 3.2 x 1.8 mm ceramic package Stratum 3 TCXO ideal for Femtocell, Nanocell and Instrumentation applications.

Request a Sample

**OPERATING CONDITIONS / ELECTRICAL CHARACTERISTICS**



- CMOS TCXO
- Stratum 3
- 5.0 x 3.2 mm Footprint
- PbFree/RoHS Compliant
- MSL 1
- Lead Finish Au

ECS-TXO53-S3					
Parameters	MIN	TYP	MAX	Units	Conditions
Frequency Range	10.000		52.000	MHz	
Initial Frequency Tolerance			±1.0	ppm	@ +25°C ±2°C
Frequency Tolerance After Reflow			±1.0	ppm	Up to 2 Reflows. Note 1:
Frequency Stability			±280	ppb	Vs. Temp (-40 ~ +85°C) Note 2 BN Opt
			±0.2	ppm	Vs. Supply Change (±5%)
			±0.2	ppm	Vs. Load Change (±5%)
Input Voltage	+3.14	+3.3	+3.47	VDC	VDD (33 Opt)
Current Consumption			8.0	mA	w/ 15 pF load
Output Voltage Low			0.33	VDC	3.3V
Output Voltage High	2.97			VDC	3.3V
Output Load			15	pF	CMOS
Start-up Time			2.5	mS	
Aging			±1.0	ppm	1 year, Note 3
Rise Time			10	nS	10% to 90% output swing
Fall Time			10	nS	90% to 10% output swing
Duty Cycle	45		55	%	
Free Run Stability for 20 Year			±4.6	ppm	Note 4
24hr Holdover Stability			±40	ppb	Note 5
Phase Noise @ 50.000 MHz			-55	dBc/Hz	@ 1 Hz Offset
			-83	dBc/Hz	@ 10 Hz Offset
			-108	dBc/Hz	@ 100 Hz Offset
			-130	dBc/Hz	@ 1 KHz Offset
			-148	dBc/Hz	@ 10 KHz Offset
			-155	dBc/Hz	@ 100 KHz Offset
VC-TXO53-S3					VC-TCXO Option
Control Voltage	+0.5	+1.5	+2.5	V	Input Impedance 100kΩ Min
Pullability	±5		±16	ppm	Positive Slope ≤10% Linearity
Operating Temperature	-40		+85	°C	* N Option
Storage Temperature	-55		+125	°C	

**Note 1:** Operation 2 hours post reflow, refer to nominal frequency

**Note 2:** Ref (Fmax + Fmin) / 2

**Note 3:** Ref after 48hrs continuous operation and fix temperature

**Note 4:** Inclusive of initial tolerance at 25°C, temperature, supply voltage ±5%, load ±5%, reflow soldering and ageing 20 years

**Note 5:** Holdover 24 hours at constant temperature after 48 hours operation

**Part Numbering Guide: Example ECS-TXO53-S3-33-500-BN-TR**

ECS	-	Series	-	Voltage	Frequency	-	Stability	Temperature
Package								

ECS	TXO53-S3 = TCXO VC-TXO53-S3 = VC-TCXO	33 = 3.3V ±5% 30 = 3.0V ±5% 50 = 5.0V ±5%	500 = 50.000 MHz  See Page 2 Developed Frequencies	B= ±280 ppb	M= -20 ~ +70°C Y = -30 ~ +85°C N = -40 ~ +85°C	TR = Tape & Reel
-----	--	---	---	-------------	--	---------------------

## Package Dimensions (mm)

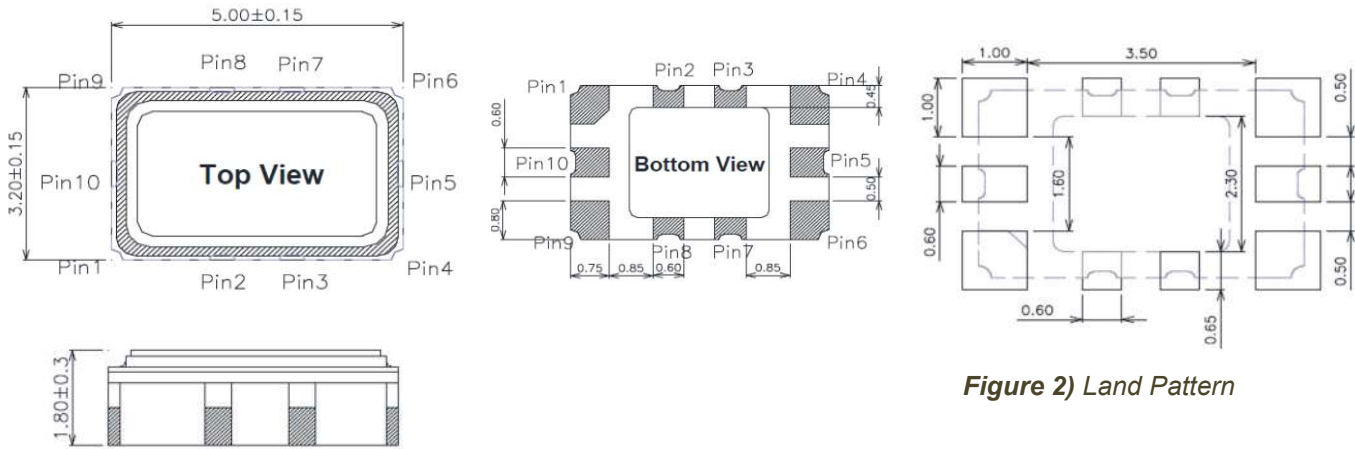

Figure 1) Top, Side, and Bottom views

Figure 2) Land Pattern

ECS-TXO53-S3	
Pin Connections	
#1	Ground or NC
#2	No Connect
#3	Tri-State
#4	Ground
#5	No Connect
#6	Output
#7	No Connect
#8	No Connect
#9	VCC
#10	No Connect

ECS-VC-TXO53-S3	
Pin Connections	
#1	Voltage Control
#2	No Connect
#3	Tri-State
#4	Ground
#5	No Connect
#6	Output
#7	No Connect
#8	No Connect
#9	VCC
#10	No Connect

Tri State Function	
Pin 3	Output
High or NC	Output Enabled
Low	Output Disabled

Developed Frequencies	
* Abbreviation	Frequency (MHz)
100	10.000
200	20.000
250	25.000
400	40.000
500	50.000

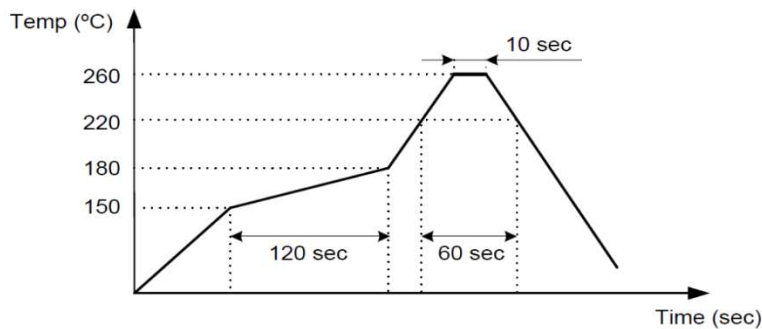

Figure 3) Suggested Reflow Profile

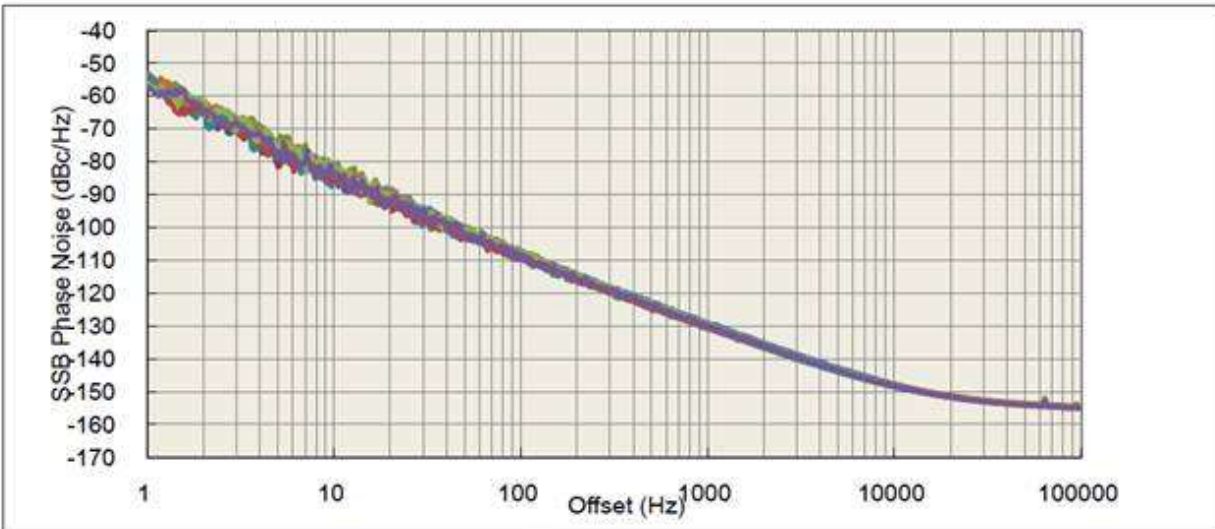
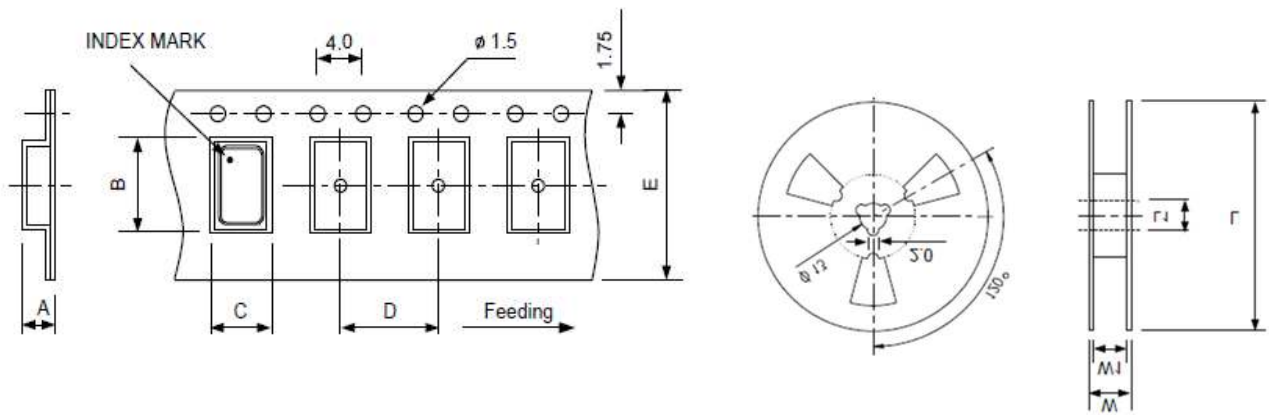

Figure 4) Typical Phase Noise Plot (50 MHz)



DIMENSIONS (mm)	A	B	C	D	E	L	L1	W	W1
	2.20	5.30	3.50	8.00	12.00	180	13.0	16.5	12.0

Figure 5) Tape & Reel Packaging