

REVISIONS					
P	LTR	DESCRIPTION	DATE	DMN	APVD
A2		REVISED ECR-19-019743	02JUN2020	J.J	W.H

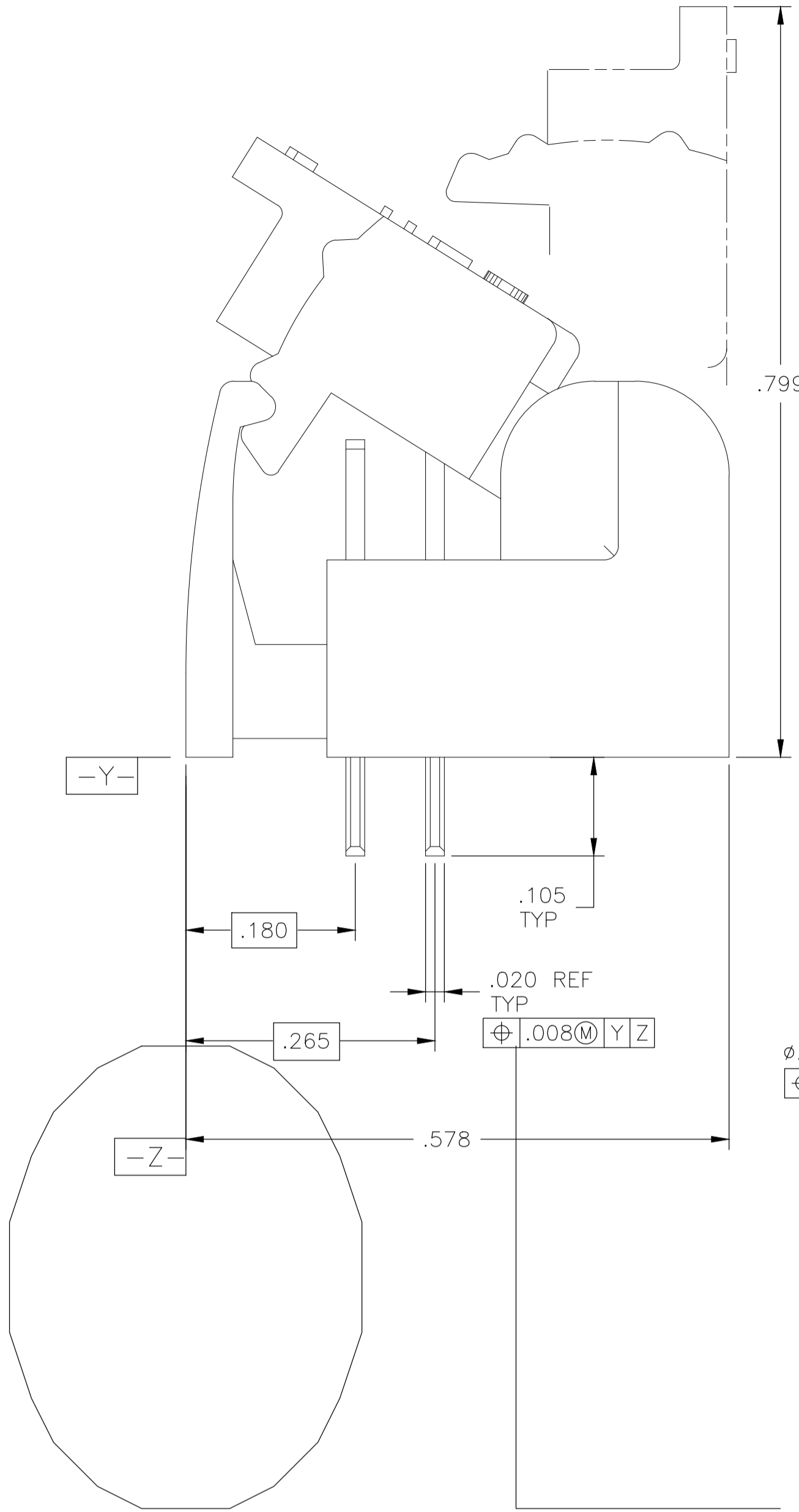

- ① MATERIAL: BASE - POLYESTER MOLDING COMPOUND, BLACK
WIRE STUFFER: - POLYESTER MOLDING COMPOUND, CLEAR ①
AND PURPLE ②
- TERMINAL - COPPER ALLOY, PLATED WITH 3.81μm MINIMUM THICK
TIN OVER 1.27μm MINIMUM THICK NICKEL UNDERPLATE.
- ② EACH WIRE ENTRY HOLE ACCEPTS ONE UNSTRIPPED SOLID COPPER
22-26 AWG WIRE WITH WIRE INSULATION DIAMETER RANGE FROM
.060 THROUGH .040. OTHER WIRE SIZES AND TYPES SHALL BE
SUBMITTED TO AMP ENGINEERS FOR APPLICATION APPROVAL.
- 3. SOLDER TABS PROVIDED FOR PERMANENT BOARD MOUNTING.
- ④ LOCATION OF HOLE PATTERN DETERMINED BASED ON CUSTOMER
REQUIREMENTS.

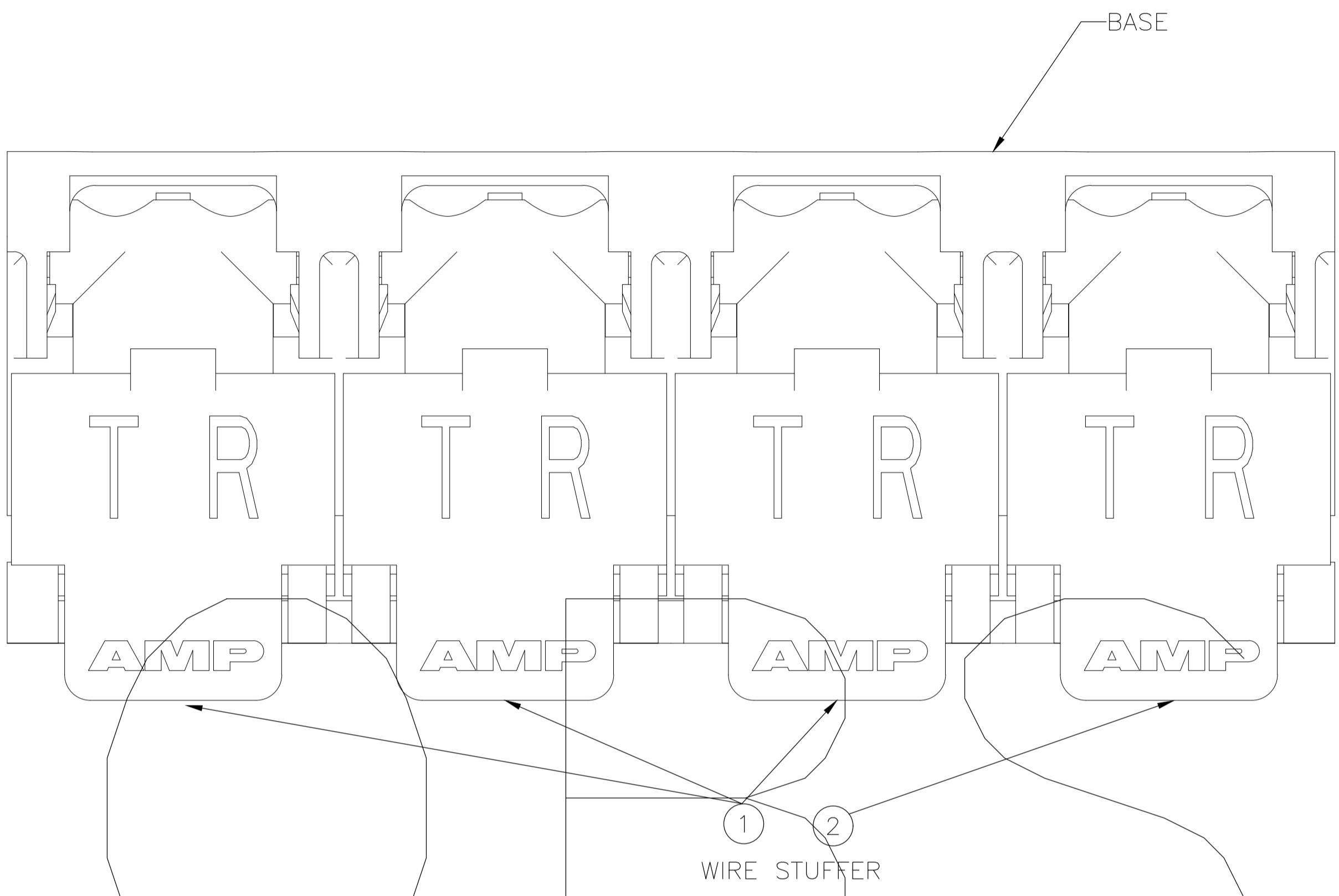
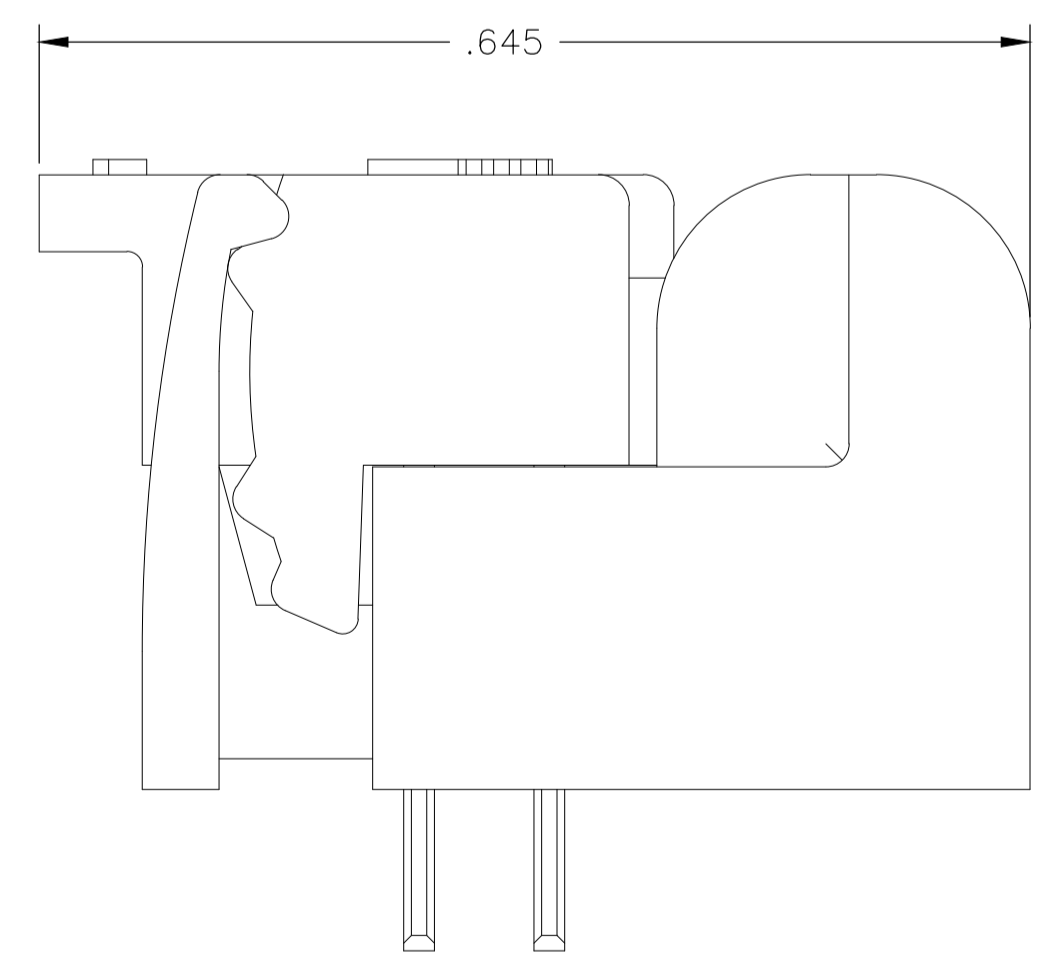
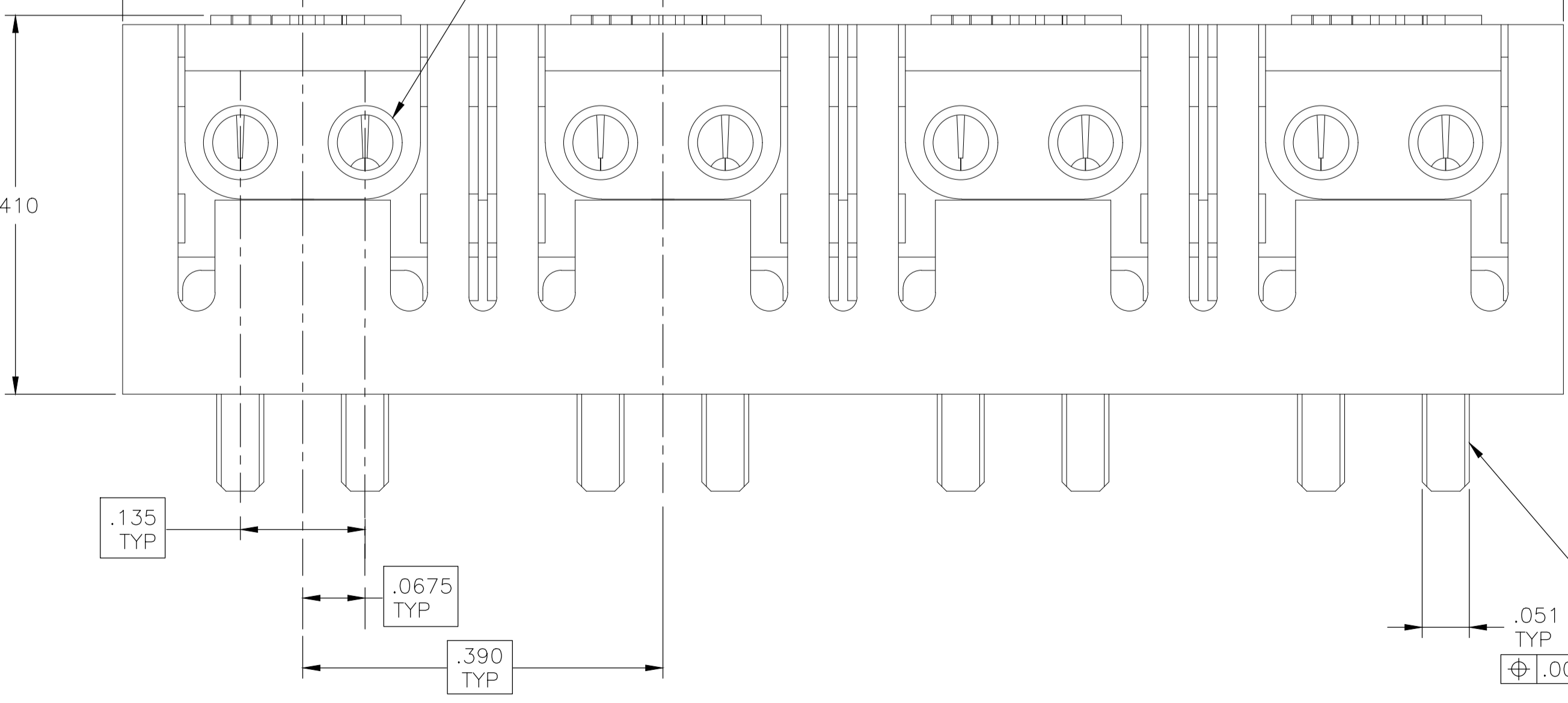
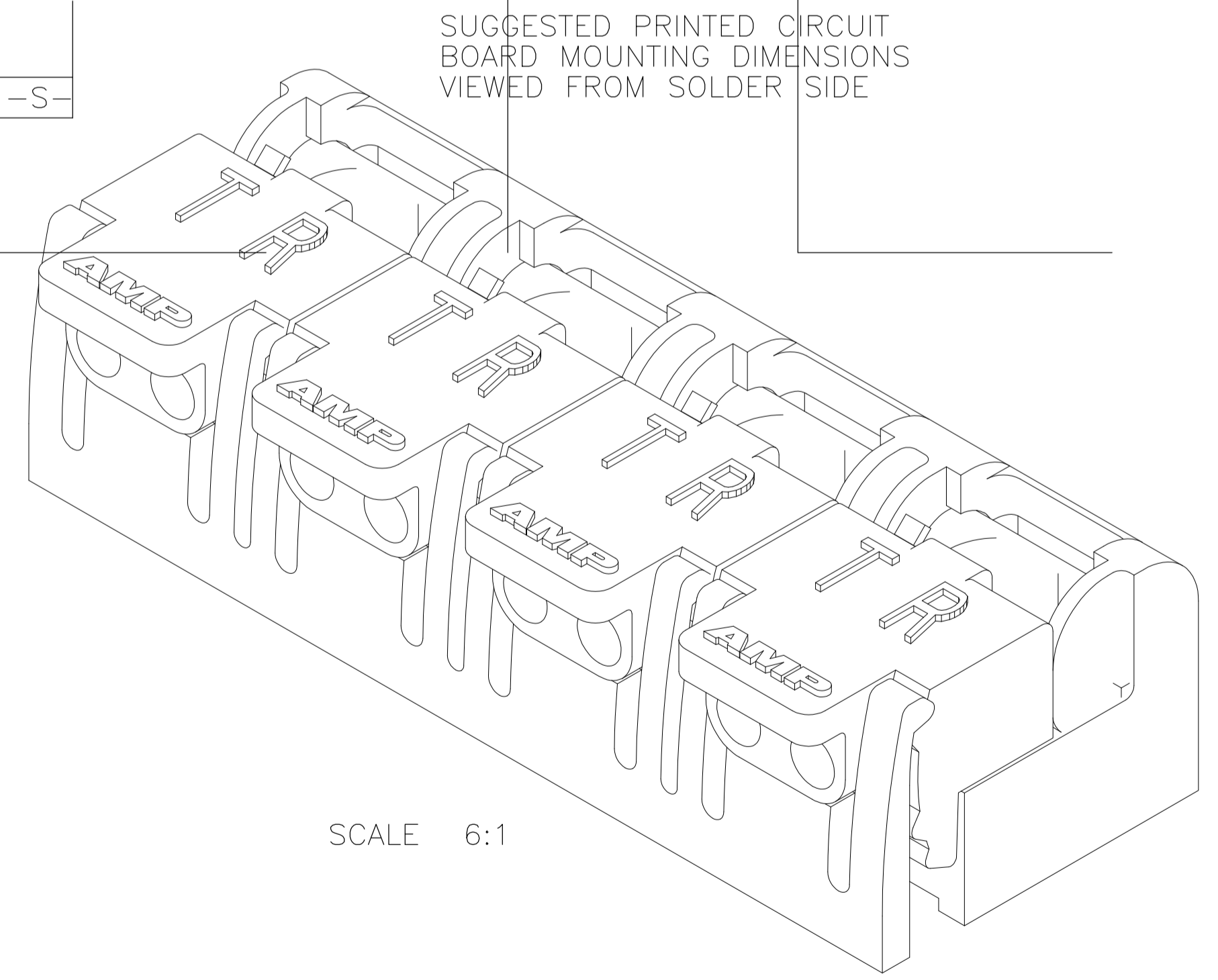
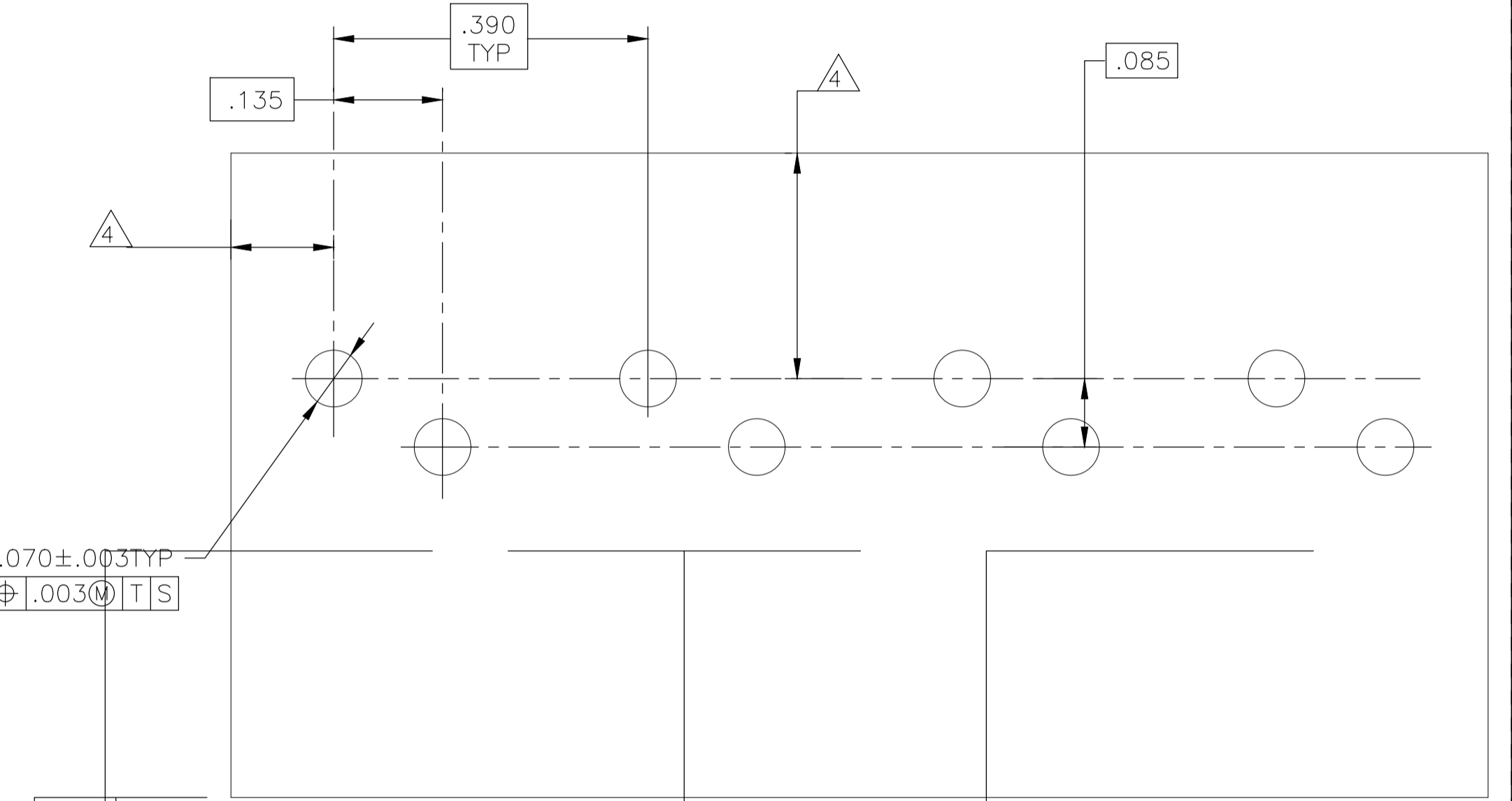

CLOSED POSITION

TERMINAL
.051 REF TYP
⊕ .008 Ⓜ Y X Ⓢ

② PURPLE ①	① CLEAR ①	1932559-1
STUFFER COLOR		P/N
STE TE Connectivity		
THIS DRAWING IS A CONTROLLED DOCUMENT. DIMENSIONS: mm TOLERANCES UNLESS OTHERWISE SPECIFIED: 0. PLC ± - 1. PLC ± .01 2. PLC ± .01 3. PLC ± .005 4. PLC ANGLES ± °		BIN C.ZHU 15JAN2010 CHK S.YAO 15JAN2010 APVD S.YAO NAME PRODUCT SPEC 108-1657 APPLICATION SPEC 114-6062 WEIGHT 0 CUSTOMER DRAWING
ASSEMBLY, FOUR PAIR SINGLE ENTRY PIVOT II CONNECTOR		SIZE A1 CAGE CODE 00779 DRAWING NO. 1932559 RESTRICTED TO
SCALE 8:1		SHEET 1 OF 1 REV A2