

---

---

## maXTouch 2911-node Touchscreen Controller Product Brief

---

---

### Description

The mXT2952TD 1.0 uses a unique charge-transfer acquisition engine to implement Microchip's patented capacitive sensing method. Coupled with a state-of-the-art CPU, the entire touchscreen sensing solution can measure, classify and track a number of individual finger touches with a high degree of accuracy in the shortest response time. The mXT2952TD 1.0 allows for both mutual and self capacitance measurements, with the self capacitance measurements being used to augment the mutual capacitance measurements to produce reliable touch information.

### maXTouch<sup>®</sup> Adaptive Sensing Touchscreen Technology

- Up to 41 X (transmit) lines and 71 Y (receive) lines for use by touchscreen and keys
- Touchscreen size 21 inches (16:9 aspect ratio), assuming a sensor electrode pitch of 6.5 mm. Other sizes are possible with different electrode pitches and appropriate sensor material
- A maximum of 2911 X/Y nodes can be allocated to the touch sensor
- Multiple touch support with up to 16 concurrent touches tracked in real time
- HID Mouse mode reporting of single touches to the host, subject to configuration
- Dual-boot OS support for Microsoft<sup>®</sup> Windows<sup>®</sup> and Android<sup>™</sup>

### Keys

- Up to 32 nodes can be allocated as mutual capacitance sensor keys (subject to other configurations)
- Adjacent Key Suppression (AKS) technology is supported for false key touch prevention

### Touch Sensor Technology

- Discrete/out-cell support including glass and PET film-based sensors
- On-cell/touch-on display support including TFT, IPS and OLED
- Synchronization with display refresh timing capability
- Support for standard (for example, Diamond) and proprietary sensor patterns (review of designs by Microchip or a Microchip-qualified touch sensor module partner is recommended)

### Front Panel Material

- Works with PET or glass, including curved profiles (configuration and stack-up to be approved by Microchip or a Microchip-qualified touch sensor module partner)
- 10 mm glass (or 5 mm PMMA) with bare finger (dependent on screen size, touch size, configuration and stack-up)
- 6 mm glass (or 3 mm PMMA) with multi-finger 5 mm glove (2.7 mm PMMA equivalent) (dependent on screen size, touch size, configuration and stack-up)

### Touch Performance

- Moisture/Water Compensation
  - No false touch with condensation or water drop up to 22 mm diameter
  - One-finger tracking with condensation or water drop up to 22 mm diameter
- Mutual capacitance and self capacitance measurements supported for robust touch detection
- P2P mutual capacitance measurements supported for extra sensitive multi-touch sensing
- Noise suppression technology to combat ambient, charger, and power-line noise
  - Up to 240 V<sub>PP</sub> between 1 Hz and 1 kHz sinusoidal waveform
  - Up to 20 V<sub>PP</sub> between 1 kHz and 1 MHz sinusoidal waveform
- Stylus Support
  - Supports passive stylus with 1.5 mm contact diameter, subject to configuration, stack-up, and sensor design
- Burst Frequency
  - Flexible and dynamic Tx burst frequency selection to reduce EMC disturbance
  - Configurable Tx waveform shaping to reduce emissions

# MXT2952TD 1.0

---

- Scan Speed
  - Up to 112 Hz report rate for one finger (subject to configuration)
  - Typical report rate for 10 touches  $\geq 100$  Hz (subject to configuration)
  - Initial touch latency  $< 14$  ms for first touch from idle (subject to configuration)
  - Configurable to allow for power and speed optimization
- Touch panel failure detection
  - Automatic touch sensor diagnostics during run time to support the implementation of safety critical features
  - Diagnostics reported using dedicated output pin or by standard Object Protocol messages
  - Configurable test limits

## On-chip Gestures

- Reports one-touch and two-touch gestures
- Supports wake up/unlock gestures, including symbol recognition

## Enhanced Algorithms

- Lens bending algorithms to remove display noise
- Touch suppression algorithms to remove unintentional large touches, such as palm
- Palm Recovery Algorithm for quick restoration to normal state

## Power Saving

- Programmable timeout for automatic transition from Active to Idle state
- Pipelined analog sensing detection and digital processing to optimize system power efficiency

## Application Interfaces

- I<sup>2</sup>C slave with support for Standard mode (up to 100 kHz), Fast mode (up to 400 kHz), Fast-mode Plus (up to 1 MHz), High Speed mode (up to 3.4 MHz)
- USB HID interface for Microsoft Windows 8.x and later versions
- HID-I<sup>2</sup>C interface for Microsoft Windows 8.x and later versions
- Interrupt to indicate when a message is available
- Additional SPI Debug Interface to read the raw data for tuning and debugging purposes

## Power Supply

- Digital (V<sub>dd</sub>) 3.3V nominal
- Digital I/O (V<sub>ddIO</sub>) 1.8V to 3.3V (I<sup>2</sup>C mode), 3.3V (USB mode)
- Analog (AV<sub>dd</sub>) 3.3V nominal
- High voltage external X line drive (XV<sub>dd</sub>) up to 9.2V

## Package

- 162-ball UFBGA 10 × 5 × 0.6 mm, 0.5 mm pitch

## Operating Temperature

- $-40^{\circ}\text{C}$  to  $+85^{\circ}\text{C}$

**PIN CONFIGURATION**

**0.1 162-ball UFBGA**

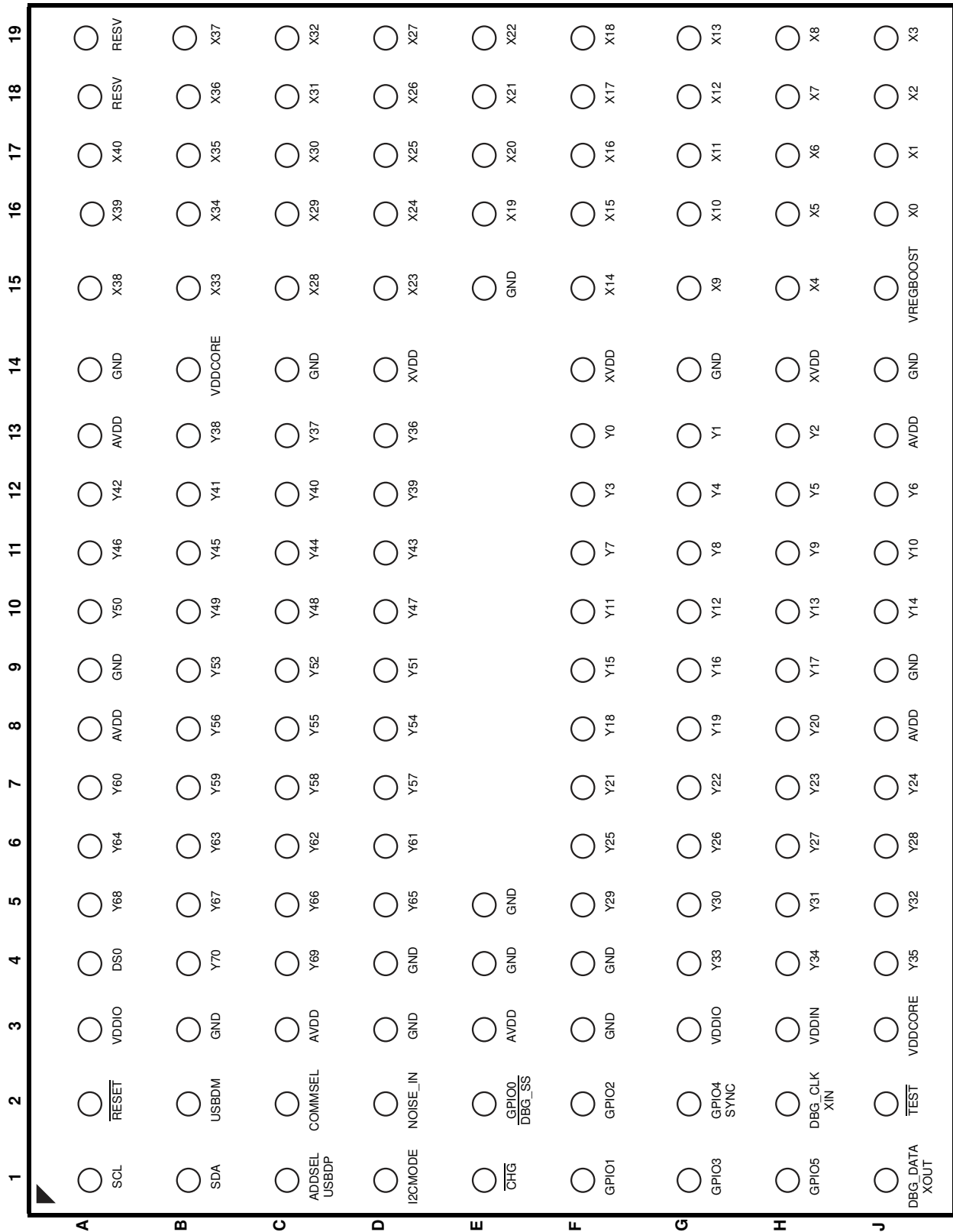

Top View

# mXT2952TD 1.0

## 1.0 PACKAGING INFORMATION

### 162-Ball Ultra Thin Fine Pitch Ball Grid Array (C6B) - 10x5x0.6 mm Body [UFBGA] Atmel Legacy Global Package Code CAK

**Note:** For the most current package drawings, please see the Microchip Packaging Specification located at <http://www.microchip.com/packaging>

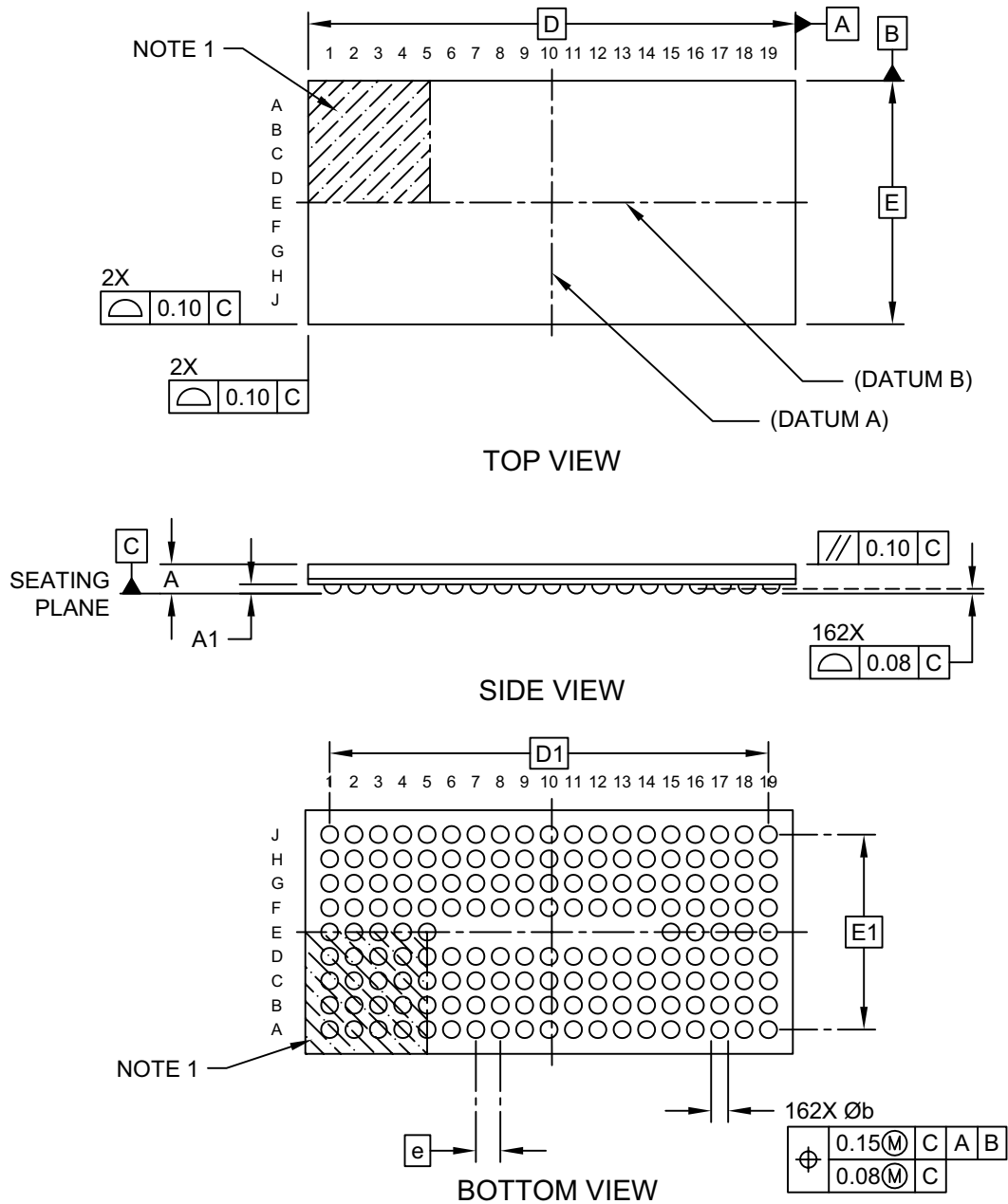

Microchip Technology Drawing C04-21167 Rev A Sheet 1 of 2

## 162-Ball Ultra Thin Fine Pitch Ball Grid Array (C6B) - 10x5x0.6 mm Body [UFBGA] Atmel Legacy Global Package Code CAK

**Note:** For the most current package drawings, please see the Microchip Packaging Specification located at <http://www.microchip.com/packaging>

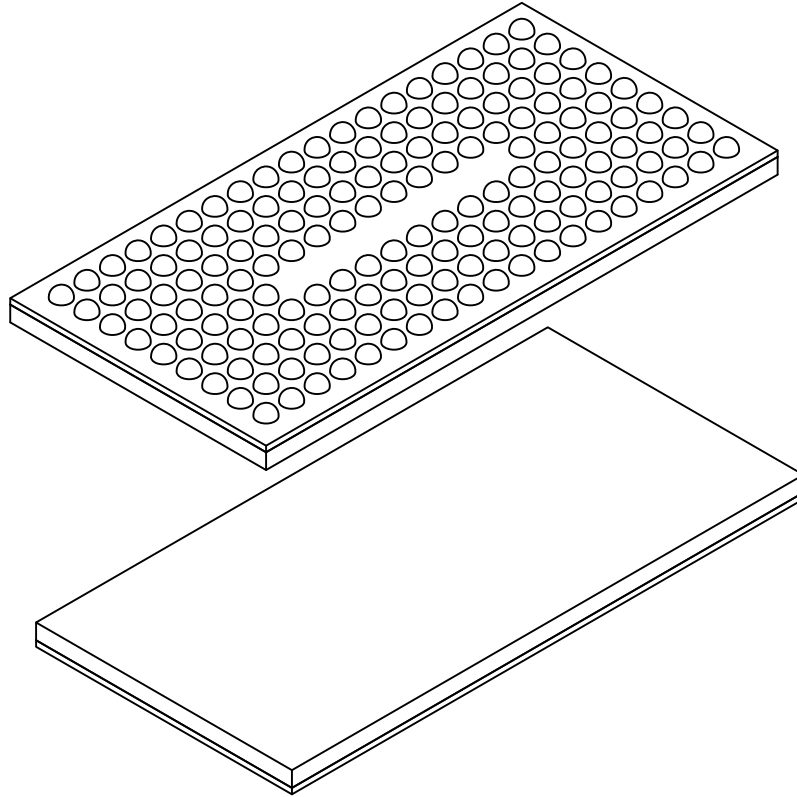

Dimension Limits	Units	MILLIMETERS		
		MIN	NOM	MAX
Number of Terminals	N	162		
Pitch	e	0.50 BSC		
Overall Height	A	0.488	0.546	0.60
Standoff	A1	0.120	0.155	0.190
Overall Length	D	10.00 BSC		
Overall Ball Spacing	D1	9.00 BSC		
Overall Width	E	5.00 BSC		
Exposed Pad Width	E1	4.00 BSC		
Ball Diameter	b	0.20	0.25	0.30

**Notes:**

- Pin 1 visual index feature may vary, but must be located within the hatched area.
- Dimensioning and tolerancing per ASME Y14.5M  
BSC: Basic Dimension. Theoretically exact value shown without tolerances.  
REF: Reference Dimension, usually without tolerance, for information purposes only.

Microchip Technology Drawing C04-21167 Rev A Sheet 2 of 2

# mXT2952TD 1.0

## 162-Ball Ultra Thin Fine Pitch Ball Grid Array (C6B) - 10x5x0.6 mm Body [UFBGA] Atmel Legacy Global Package Code CAK

**Note:** For the most current package drawings, please see the Microchip Packaging Specification located at <http://www.microchip.com/packaging>

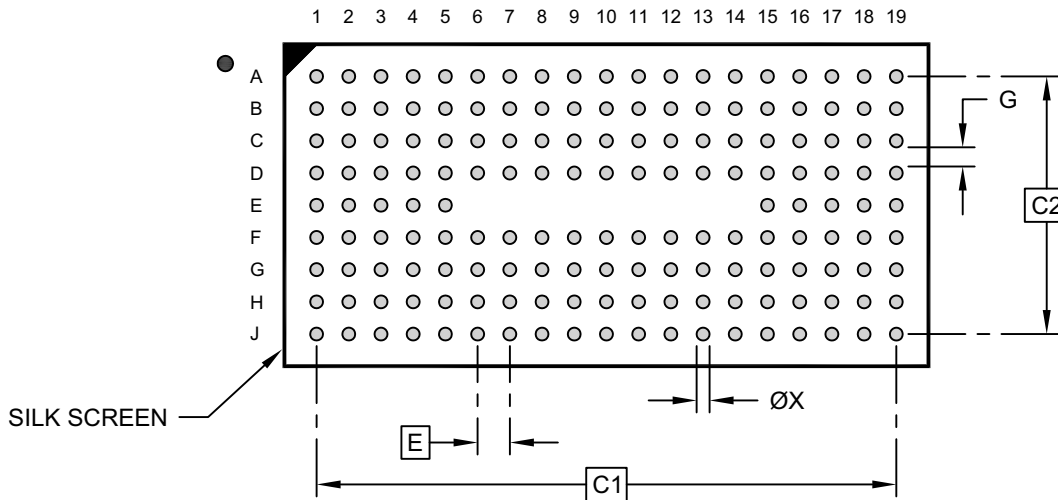

### RECOMMENDED LAND PATTERN

Dimension Limits	Units	MILLIMETERS		
		MIN	NOM	MAX
Contact Pitch	E	0.50 BSC		
Contact Pad Spacing	C1	9.00 BSC		
Contact Pad Spacing	C2	4.00 BSC		
Contact Pad Diameter (X162)	X1			0.20
Contact Pad to Contact Pad	G	0.30		

**Notes:**

1. Dimensioning and tolerancing per ASME Y14.5M

BSC: Basic Dimension. Theoretically exact value shown without tolerances.

Microchip Technology Drawing C04-23167 Rev A

## APPENDIX A: REVISION HISTORY

### Revision A (July 2019)

Initial edition for firmware revision 1.0.AA – Release

# mXT2952TD 1.0

## PRODUCT IDENTIFICATION SYSTEM

The table below gives details on the product identification system for maXTouch devices. See ["Orderable Part Numbers"](#) below for example part numbers for the mXT2952TD.

To order or obtain information, for example on pricing or delivery, refer to the factory or the listed sales office.

PART NO.	-XXX	[X]	[X]	[XXX]
Device	Package	Temperature Range	Tape and Reel Option	Pattern
Device:	Base device name			
Package:	A	=	QFP (Plastic Quad Flatpack)	
	CC	=	UFBGA (Ultra Thin Fine-pitch Ball Grid Array)	
	C2	=	UFBGA (Ultra Thin Fine-pitch Ball Grid Array)	
	NH	=	UFBGA (Ultra Thin Fine-pitch Ball Grid Array)	
	C4	=	X1FBGA (Extra Thin Fine-pitch Ball Grid Array)	
	MA	=	XQFN (Super Thin Quad Flat No Lead Sawn)	
	MA5	=	XQFN (Super Thin Quad Flat No Lead Sawn)	
Temperature Range:	U	=	-40°C to +85°C (Grade 3)	
	T	=	-40°C to +85°C (Grade 3)	
	B	=	-40°C to +105°C (Grade 2)	
Tape and Reel Option:	<i>Blank</i>	=	Standard Packaging (Tube or Tray)	
	R	=	Tape and Reel <sup>(1)</sup>	
Pattern:	Extension, QTP, SQTP, Code or Special Requirements (Blank Otherwise)			

**Note 1:** Tape and Reel identifier only appears in the catalog part number description. This identifier is used for ordering purposes and is not printed on the device package. See ["Orderable Part Numbers"](#) below or check with your Microchip Sales Office for package availability with the Tape and Reel option.

## Orderable Part Numbers

Orderable Part Number	Firmware Revision	Description
ATMXT2952TD-C2U001 (Supplied in trays)	1.0.AA	162-ball UFBGA 10 × 5 × 0.6 mm, RoHS compliant Industrial grade; not suitable for automotive characterization
ATMXT2952TD-C2UR001 (Supplied in tape and reel)		



---

Note the following details of the code protection feature on Microchip devices:

- Microchip products meet the specification contained in their particular Microchip Data Sheet.
- Microchip believes that its family of products is one of the most secure families of its kind on the market today, when used in the intended manner and under normal conditions.
- There are dishonest and possibly illegal methods used to breach the code protection feature. All of these methods, to our knowledge, require using the Microchip products in a manner outside the operating specifications contained in Microchip's Data Sheets. Most likely, the person doing so is engaged in theft of intellectual property.
- Microchip is willing to work with the customer who is concerned about the integrity of their code.
- Neither Microchip nor any other semiconductor manufacturer can guarantee the security of their code. Code protection does not mean that we are guaranteeing the product as “unbreakable.”

Code protection is constantly evolving. We at Microchip are committed to continuously improving the code protection features of our products. Attempts to break Microchip's code protection feature may be a violation of the Digital Millennium Copyright Act. If such acts allow unauthorized access to your software or other copyrighted work, you may have a right to sue for relief under that Act.

---

Information contained in this publication regarding device applications and the like is provided only for your convenience and may be superseded by updates. It is your responsibility to ensure that your application meets with your specifications. MICROCHIP MAKES NO REPRESENTATIONS OR WARRANTIES OF ANY KIND WHETHER EXPRESS OR IMPLIED, WRITTEN OR ORAL, STATUTORY OR OTHERWISE, RELATED TO THE INFORMATION, INCLUDING BUT NOT LIMITED TO ITS CONDITION, QUALITY, PERFORMANCE, MERCHANTABILITY OR FITNESS FOR PURPOSE. Microchip disclaims all liability arising from this information and its use. Use of Microchip devices in life support and/or safety applications is entirely at the buyer's risk, and the buyer agrees to defend, indemnify and hold harmless Microchip from any and all damages, claims, suits, or expenses resulting from such use. No licenses are conveyed, implicitly or otherwise, under any Microchip intellectual property rights unless otherwise stated.

#### Trademarks

The Microchip name and logo, the Microchip logo, Adaptec, AnyRate, AVR, AVR logo, AVR Freaks, BesTime, BitCloud, chipKIT, chipKIT logo, CryptoMemory, CryptoRF, dsPIC, FlashFlex, flexPWR, HELDO, IGLOO, JukeBlox, KeeLoq, Klear, LANCheck, LinkMD, maXStylus, maXTouch, MediaLB, megaAVR, Microsemi, Microsemi logo, MOST, MOST logo, MPLAB, OptoLyzer, PackeTime, PIC, picoPower, PICSTART, PIC32 logo, PolarFire, Prochip Designer, QTouch, SAM-BA, SenGenuity, SpyNIC, SST, SST Logo, SuperFlash, Symmetricom, SyncServer, Tachyon, TempTrackr, TimeSource, tinyAVR, UNI/O, Vectron, and XMEGA are registered trademarks of Microchip Technology Incorporated in the U.S.A. and other countries.

APT, ClockWorks, The Embedded Control Solutions Company, EtherSynch, FlashTec, Hyper Speed Control, HyperLight Load, IntelliMOS, Libero, motorBench, mTouch, Powermite 3, Precision Edge, ProASIC, ProASIC Plus, ProASIC Plus logo, Quiet-Wire, SmartFusion, SyncWorld, Temux, TimeCesium, TimeHub, TimePictra, TimeProvider, Vite, WinPath, and ZL are registered trademarks of Microchip Technology Incorporated in the U.S.A.

Adjacent Key Suppression, AKS, Analog-for-the-Digital Age, Any Capacitor, AnyIn, AnyOut, BlueSky, BodyCom, CodeGuard, CryptoAuthentication, CryptoAutomotive, CryptoCompanion, CryptoController, dsPICDEM, dsPICDEM.net, Dynamic Average Matching, DAM, ECAN, EtherGREEN, In-Circuit Serial Programming, ICSP, INICnet, Inter-Chip Connectivity, JitterBlocker, KlearNet, KlearNet logo, memBrain, Mindi, MiWi, MPASM, MPF, MPLAB Certified logo, MPLIB, MPLINK, MultiTRAK, NetDetach, Omniscient Code Generation, PICDEM, PICDEM.net, PICkit, PICtail, PowerSmart, PureSilicon, QMatrix, REAL ICE, Ripple Blocker, SAM-ICE, Serial Quad I/O, SMART-I.S., SQI, SuperSwitcher, SuperSwitcher II, Total Endurance, TSHARC, USBCheck, VariSense, ViewSpan, WiperLock, Wireless DNA, and ZENA are trademarks of Microchip Technology Incorporated in the U.S.A. and other countries.

SQTP is a service mark of Microchip Technology Incorporated in the U.S.A.

The Adaptec logo, Frequency on Demand, Silicon Storage Technology, and Symmcom are registered trademarks of Microchip Technology Inc. in other countries.

GestIC is a registered trademark of Microchip Technology Germany II GmbH & Co. KG, a subsidiary of Microchip Technology Inc., in other countries.

All other trademarks mentioned herein are property of their respective companies.

© 2019, Microchip Technology Incorporated, All Rights Reserved.

ISBN: 978-1-5224-4673-6

For information regarding Microchip's Quality Management Systems, please visit [www.microchip.com/quality](http://www.microchip.com/quality).

---



---

## Worldwide Sales and Service

---



---

### AMERICAS

**Corporate Office**  
 2355 West Chandler Blvd.  
 Chandler, AZ 85224-6199  
 Tel: 480-792-7200  
 Fax: 480-792-7277  
 Technical Support:  
[http://www.microchip.com/  
 support](http://www.microchip.com/support)  
 Web Address:  
[www.microchip.com](http://www.microchip.com)

#### Atlanta

Duluth, GA  
 Tel: 678-957-9614  
 Fax: 678-957-1455

#### Austin, TX

Tel: 512-257-3370

#### Boston

Westborough, MA  
 Tel: 774-760-0087  
 Fax: 774-760-0088

#### Chicago

Itasca, IL  
 Tel: 630-285-0071  
 Fax: 630-285-0075

#### Dallas

Addison, TX  
 Tel: 972-818-7423  
 Fax: 972-818-2924

#### Detroit

Novi, MI  
 Tel: 248-848-4000

#### Houston, TX

Tel: 281-894-5983

#### Indianapolis

Noblesville, IN  
 Tel: 317-773-8323  
 Fax: 317-773-5453  
 Tel: 317-536-2380

#### Los Angeles

Mission Viejo, CA  
 Tel: 949-462-9523  
 Fax: 949-462-9608  
 Tel: 951-273-7800

#### Raleigh, NC

Tel: 919-844-7510

#### New York, NY

Tel: 631-435-6000

#### San Jose, CA

Tel: 408-735-9110  
 Tel: 408-436-4270

#### Canada - Toronto

Tel: 905-695-1980  
 Fax: 905-695-2078

### ASIA/PACIFIC

**Australia - Sydney**  
 Tel: 61-2-9868-6733

**China - Beijing**  
 Tel: 86-10-8569-7000

**China - Chengdu**  
 Tel: 86-28-8665-5511

**China - Chongqing**  
 Tel: 86-23-8980-9588

**China - Dongguan**  
 Tel: 86-769-8702-9880

**China - Guangzhou**  
 Tel: 86-20-8755-8029

**China - Hangzhou**  
 Tel: 86-571-8792-8115

**China - Hong Kong SAR**  
 Tel: 852-2943-5100

**China - Nanjing**  
 Tel: 86-25-8473-2460

**China - Qingdao**  
 Tel: 86-532-8502-7355

**China - Shanghai**  
 Tel: 86-21-3326-8000

**China - Shenyang**  
 Tel: 86-24-2334-2829

**China - Shenzhen**  
 Tel: 86-755-8864-2200

**China - Suzhou**  
 Tel: 86-186-6233-1526

**China - Wuhan**  
 Tel: 86-27-5980-5300

**China - Xian**  
 Tel: 86-29-8833-7252

**China - Xiamen**  
 Tel: 86-592-2388138

**China - Zhuhai**  
 Tel: 86-756-3210040

### ASIA/PACIFIC

**India - Bangalore**  
 Tel: 91-80-3090-4444

**India - New Delhi**  
 Tel: 91-11-4160-8631

**India - Pune**  
 Tel: 91-20-4121-0141

**Japan - Osaka**  
 Tel: 81-6-6152-7160

**Japan - Tokyo**  
 Tel: 81-3-6880-3770

**Korea - Daegu**  
 Tel: 82-53-744-4301

**Korea - Seoul**  
 Tel: 82-2-554-7200

**Malaysia - Kuala Lumpur**  
 Tel: 60-3-7651-7906

**Malaysia - Penang**  
 Tel: 60-4-227-8870

**Philippines - Manila**  
 Tel: 63-2-634-9065

**Singapore**  
 Tel: 65-6334-8870

**Taiwan - Hsin Chu**  
 Tel: 886-3-577-8366

**Taiwan - Kaohsiung**  
 Tel: 886-7-213-7830

**Taiwan - Taipei**  
 Tel: 886-2-2508-8600

**Thailand - Bangkok**  
 Tel: 66-2-694-1351

**Vietnam - Ho Chi Minh**  
 Tel: 84-28-5448-2100

### EUROPE

**Austria - Wels**  
 Tel: 43-7242-2244-39  
 Fax: 43-7242-2244-393

**Denmark - Copenhagen**  
 Tel: 45-4450-2828  
 Fax: 45-4485-2829

**Finland - Espoo**  
 Tel: 358-9-4520-820

**France - Paris**  
 Tel: 33-1-69-53-63-20  
 Fax: 33-1-69-30-90-79

**Germany - Garching**  
 Tel: 49-8931-9700

**Germany - Haan**  
 Tel: 49-2129-3766400

**Germany - Heilbronn**  
 Tel: 49-7131-72400

**Germany - Karlsruhe**  
 Tel: 49-721-625370

**Germany - Munich**  
 Tel: 49-89-627-144-0  
 Fax: 49-89-627-144-44

**Germany - Rosenheim**  
 Tel: 49-8031-354-560

**Israel - Ra'anana**  
 Tel: 972-9-744-7705

**Italy - Milan**  
 Tel: 39-0331-742611  
 Fax: 39-0331-466781

**Italy - Padova**  
 Tel: 39-049-7625286

**Netherlands - Drunen**  
 Tel: 31-416-690399  
 Fax: 31-416-690340

**Norway - Trondheim**  
 Tel: 47-7288-4388

**Poland - Warsaw**  
 Tel: 48-22-3325737

**Romania - Bucharest**  
 Tel: 40-21-407-87-50

**Spain - Madrid**  
 Tel: 34-91-708-08-90  
 Fax: 34-91-708-08-91

**Sweden - Gothenberg**  
 Tel: 46-31-704-60-40

**Sweden - Stockholm**  
 Tel: 46-8-5090-4654

**UK - Wokingham**  
 Tel: 44-118-921-5800  
 Fax: 44-118-921-5820