

PART NUMBER	REVISION	DESCRIPTION	FEED TYPE
2151493-1	L	FINE CRIMP HEIGHT ADJUST	MECHANICAL
2151493-2	L	FINE CRIMP HEIGHT ADJUST	PNEUMATIC
3-2151493-2	L	FINE CRIMP HEIGHT ADJUST	DOUBLE ACTING PNEUMATIC WITH SENSORS
5-2151493-1	L	SEAL STRIPPER CRIMPER TERMINATING UNIT	MECHANICAL
5-2151493-2	L	SEAL STRIPPER CRIMPER TERMINATING UNIT	PNEUMATIC
7-2151493-1	L	MECHANICAL AND CRIMP TOOLING KIT	MECHANICAL
7-2151493-2	L	PNEUMATIC AND CRIMP TOOLING KIT	PNEUMATIC
7-2151493-7	A	CRIMP TOOLING KIT	-

ATLANTIC VERSION TERMINATOR INTERFACE ADAPTER

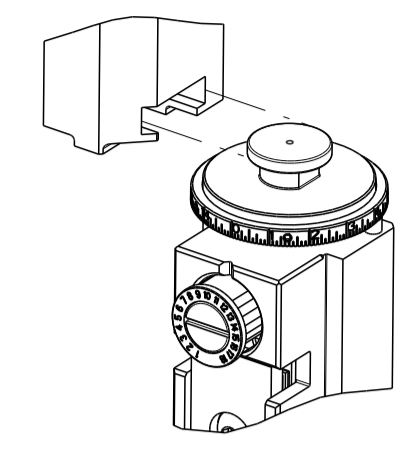

APPLICATOR DATA		
CRIMP	SIZE	TYPE
WIRE	1.40 mm [.055]	F
INSUL	1.83 mm [.072]	O

APPLICATOR INSTRUCTIONS  
408-35042

TERMINAL DATA: TE TERMINAL		TE CRIMP SPECIFICATION	
TERMINAL NAME: MICRO QUADOCK SYSTEM			
WIRE STRIP LENGTH	INSULATION DIAMETER RANGE		
3.45-3.75 mm [.136-.148 IN]	Ø 1.10-1.60 mm [.043-.063 IN]		
TERMINAL APPLICATION SPECIFICATION	(A) 114-18021		
	(B) 114-61024		

TERMINALS APPLIED			
GROUP 1		GROUP 2	
TE TERMINAL	TE TERMINAL	TE TERMINAL	TE TERMINAL
(A) 928999-1	(A) 5-928918-2	(A) 968220-1	(A) 1703296-1
(A) 928999-5	(A) 5-928918-1	(A) 968220-5	(A) 1703296-5
(A) 928999-6	(A) 6-928918-1	(A) 968220-6	(A) 1534116-1
(A) 5-928999-1	(A) 6-928918-2	(A) 5-968220-1	(A) 1534116-2
(A) 968893-1	(A) 6-928918-3	(A) 5-968220-5	(A) 5-1534116-1
(A) 928918-1	(A) 1394702-1	(A) 5-968220-6	(A) 5-1534116-2
(A) 928918-2	(A) 1394702-2	(B) 2005119-1	(A) 1241918-1
(A) 1-928918-1	(A) 5-928999-5		
(A) 1-928918-2	(A) 5-928999-6		
(A) 5-1394702-1	(A) 6-928999-5		
(A) 5-1394702-2	(A) 5-968893-1		

WIRE SIZE	CRIMP HEIGHT mm [INCH]	CRIMP HEIGHT REFERENCE SETTING
Ø 0.50mm2	0.86 +/- 0.03 [.034 +/- .001]	9.0
Ø 0.35mm2	0.76 +/- 0.03 [.030 +/- .001]	9.9
Ø 22 AWG	0.76 +/- 0.03 [.030 +/- .001]	9.9
Ø 0.25mm2	0.72 +/- 0.03 [.028 +/- .001]	10.4

- RECOMMENDED SPARE PARTS
- REFER TO SUPPLIED INSTRUCTION SHEET FOR CLEANING, LUBRICATION & STORAGE OF APPLICATOR.
- APPLY PART NUMBER 1-23419-5 LOCTITE TO THREADS OF ITEM 180. APPLY PART NUMBER 2-23419-6 LOCTITE TO THREADS OF ITEM 242.
- CRIMP HEIGHT REFERENCE SETTING WAS THE SETTING USED WHEN THE APPLICATOR WAS QUALIFIED AT THE FACTORY. ADJUSTMENT MAY BE NECESSARY WHEN RUNNING APPLICATOR IN THE FIELD.
- REFER TO APPLICATION SPECIFICATION, 114-18021, PAGE 8, NOTE 3 CONCERNING CRIMPING 0.50mm<sup>2</sup> WIRE.
- POSITION THE HOLD DOWN, ITEM 18, IN ORIENTATION 1 FOR GROUP 1 TERMINALS. REFER TO SHEET 2.
- POSITION THE HOLD DOWN, ITEM 18, IN ORIENTATION 2 FOR GROUP 2 TERMINALS. REFER TO SHEET 2.

- THIS CRIMP PARAMETER IS PROVIDED TO MEET A CUSTOM AND UNIQUE CUSTOMER REQUIREMENT. IT HAS BEEN EVALUATED AND IS CONDITIONALLY SPECIFIED BY TE CONNECTIVITY. THIS CUSTOMIZED CRIMP PARAMETER IS NOT LISTED AS AN APPROVED APPLICATION WITHIN A TE CONNECTIVITY APPLICATION SPECIFICATION. **TE CONNECTIVITY EXPRESSLY DISCLAIMS ANY AND ALL WARRANTIES THAT THE PRODUCT WILL PERFORM SIMILARLY TO VALIDATED AND APPROVED APPLICATIONS, AS STATED WITHIN TE CONNECTIVITY APPLICATION SPECIFICATIONS, INCLUDING BUT NOT LIMITED TO IMPLIED WARRANTIES OF MERCHANTABILITY OR FITNESS FOR PARTICULAR PURPOSE.** AS SUCH, IT IS HIGHLY RECOMMENDED THAT THE CUSTOMER PERFORM FURTHER DETAILED EVALUATION TO ASSESS PRODUCT PERFORMANCE IN THE SPECIFIC APPLICATION.
- UNLESS SPECIFIED OTHERWISE TORQUE VALUES SHALL BE USED PER DOCUMENT, 101-35000.
- THIS APPLICATOR IS EQUIPPED WITH THE DOUBLE ACTING FEED WITH SENSORS AND IS APPLICATION SPECIFIC. IT DOES NOT REQUIRE ITEMS 49 & 248.

LOC	DIST	REVISIONS					
A	66	P	LTN	DESCRIPTION	DATE	OWN	APVD
		H4		ECR-21-000640	19JAN2021	FJ	YY
		J		ECR-21-109886	11AUG2021	JWC	RK
		K		ECR-22-161068	13DEC2022	FZ	JAH
		L		ECR-23-164268	20JAN2023	JWC	TE

-	-	-	1	1	-	-	-	1803515-3	RAM ASSEMBLY, SF ATLANTIC	293	
-	-	-	1	1	-	-	-	2-1803583-1	APPLICATOR BASIC ASSEMBLY, SF	292	
-	-	-	-	-	1	-	-	2844950-1	AIR FEED MODULE	290	
△	-	1	-	1	-	-	1	2119641-1	FEED CAM, AIR FEED	248	
-	1	1	1	1	1	1	1	2119082-5	CAM, SNAIL, INSULATION ADJUSTMENT	244	
△	-	1	1	1	1	1	1	2079764-1	WASHER, WAVE SPRING, WASHER-TO-CREST	243	
-	1	1	1	1	1	1	1	2119083-1	RETAINER, INSULATION DIAL	242	
-	1	1	1	1	1	1	1	7-18023-7	SCR, SKT HD CAP M3 X 4.0	241	
-	-	1	-	1	-	-	1	2119580-1	MECHANICAL FEED ASSEMBLY	239	
-	1	-	1	-	-	1	-	2844940-1	AIR FEED MODULE	238	
-	-	-	1	1	-	-	-	4-1722335-3	STRIPPER, SIDE FEED	182	
△	-	-	-	1	1	-	-	1-5018030-0	NUT, HEX, REG, RoHS, M3.5	181	
-	-	-	-	1	1	-	-	1-1752354-7	STANDOFF, HOLD-DOWN	180	
-	-	-	-	1	1	-	-	9931111-1	PIN, SLOTTED SPRING 3.0 X 20.0	177	
-	-	-	-	1	1	-	-	5-22280-0	SPRING, COMPRESSION	176	
-	-	-	-	1	1	-	-	1752353-3	GUIDE PIN, HOLDDOWN	175	
-	-	-	-	1	1	-	-	1901680-2	GUIDE PIN, HOLDDOWN	174	
-	REF	REF	REF	REF	REF	REF	REF	994970-2	COUNTER, MAGNETIC	164	
-	1	1	1	1	1	1	1	2844908-1	SCREW, LOCKING	99	
-	1	1	1	1	1	1	1	2844907-1	POST, LOCKING	98	
-	1	1	1	1	1	1	1	455888-5	SPACER, CRIMPER	82	
△	-	1	1	1	1	1	1	1-240641-3	SPACER	81	
△	-	2	2	2	2	2	2	2168083-1	SCR, SKT HD CAP, RoHS, M3 X 8.0	79	
-	1	1	1	1	1	1	1	1633782-2	FENCE	78	
-	1	1	1	1	1	1	1	1803607-3	DOCUMENTATION PACKAGE	71	
-	1	1	1	1	1	1	1	2119791-5	DEPRESSOR, WIRE	70	
-	1	1	1	1	1	1	1	2119943-1	WASHER, SPACER	69	
-	1	1	1	1	1	1	1	2119740-1	TAG, IDENTIFICATION	67	
-	2	2	2	2	2	2	2	2168078-1	SCREW, DRIVE, RH, RoHS, 2 x .188	66	
-	1	1	1	1	1	1	1	2168083-2	SCR, SKT HD CAP, RoHS, M4 X 8.0	60	
-	1	1	1	1	1	1	1	5-18022-5	SCR, HEX HD CAP, M4 X 6.0	59	
-	1	1	1	1	1	1	1	1338685-1	PAWL, FEED	56	
-	4	4	4	4	4	4	4	2168083-3	SCR, SKT HD CAP, RoHS, M4 X 12.0	54	
-	2	2	2	2	2	2	2	2168083-2	SCR, SKT HD CAP, RoHS, M4 X 8.0	53	
△	-	1	2	1	2	-	1	2	18023-9	SCR, SKT HD CAP M4 X 6.0	49
-	-	1	-	1	-	-	1	2119652-1	FEED CAM, PRE FEED	48	
-	-	1	-	1	-	-	1	2119653-1	FEED CAM, POST FEED	47	
-	1	1	-	-	1	1	1	1803583-9	APPLICATOR BASIC ASSEMBLY, SF	46	
-	1	1	-	-	1	1	1	1803515-1	RAM ASSEMBLY, SF ATLANTIC	44	
-	1	1	1	1	1	1	1	1803602-1	SCR, BHSC, RoHS (M8 X 25)	41	
-	1	1	1	1	1	1	1	1752356-6	SUPPORT, TERMINAL	34	
-	2	2	2	2	2	2	2	2079383-5	SCR, BHSC, RoHS (M4 X 20)	33	
-	2	2	2	2	2	2	2	2-2844962-4	SPACER, CYLINDRICAL, STRIP GUIDE	30	
-	1	1	1	1	1	1	1	2844992-1	ASSEMBLY, STRIP GUIDE	29	
-	1	1	1	1	1	1	1	1-455888-0	SPACER, CRIMPER	28	
-	1	1	1	1	1	1	1	1320928-2	STRIP GUIDE	24	
-	1	1	-	-	1	1	1	2168083-2	SCR, SKT HD CAP, RoHS, M4 X 8.0	21	
-	2	2	1	1	2	2	2	1-18028-2	WASHER, FLAT, REG M4	20	
-	1	1	-	-	1	1	1	2119533-1	STRIPPER, SIDE FEED	19	
△	-	1	1	1	1	1	1	1803155-1	HOLD DOWN, TERMINAL	18	
△	-	1	1	1	1	1	1	2119806-1	INSERT, SHEAR	13	
-	1	1	1	1	1	1	1	3-22280-3	SPRING, COMPRESSION	12	
-	1	1	1	1	1	1	1	1-356885-4	STOP, SHEAR	11	
-	1	1	1	1	1	1	1	2119805-1	SHEAR HOLDER, FRONT	10	
-	1	1	1	1	1	1	1	1803095-1	FLOATING SHEAR, FRONT	9	
△	1	2	2	1	1	1	1	1-1338690-2	ANVIL, COMBINATION .055	8	
△	-	1	1	1	1	1	1	4-240641-2	SPACER	7	
-	1	1	1	1	1	1	1	2119757-4	DEPRESSOR, SHEAR	5	
-	1	1	1	1	1	1	1	238011-8	BLOCK, CRIMPER SPACER	4	
△	1	2	2	1	1	1	1	2119784-2	CRIMPER, INSULATION O PREMIUM	3	
-	1	1	1	1	1	1	1	455888-1	SPACER, CRIMPER	2	
△	1	2	2	1	1	1	1	1-562108-5	CRIMPER, WIRE, F	1	

ATLANTIC VERSION  
Shown on sheets 1 of 4 & 2 of 4  
(Pacific version shown on sheets 3 of 4 & 4 of 4)

DIMENSIONS:		TOLERANCES UNLESS OTHERWISE SPECIFIED:		MATERIAL:		FINISH:		WEIGHT:		SCALE:	
mm	0 PLC ±	1 PLC ±	2 PLC ±	3 PLC ±	4 PLC ±	ANGLES	FINISH	Customer Accessible Production Drawing	SCALE	SHEET	REV
								00779	5:1	1 of 4	L

LOC	DIST	REV	DESCRIPTION	DATE	OWN	APVD
A	66		SEE SHEET 1			

### FEED TYPE MECHANICAL

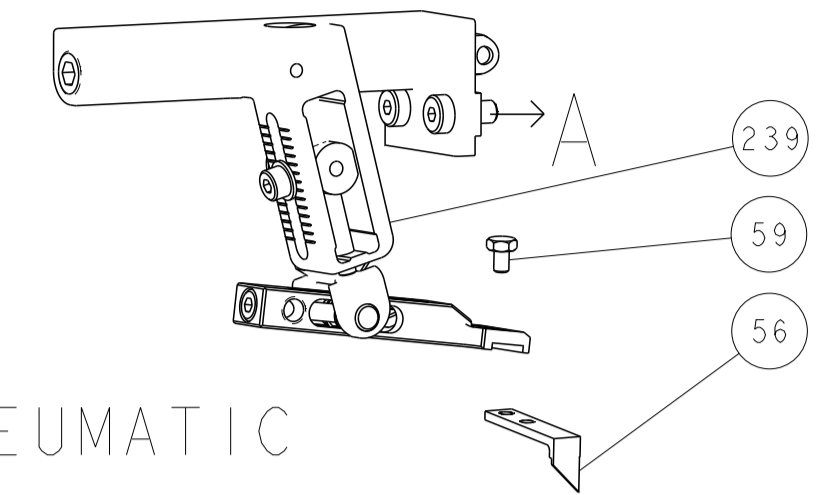

### PNEUMATIC

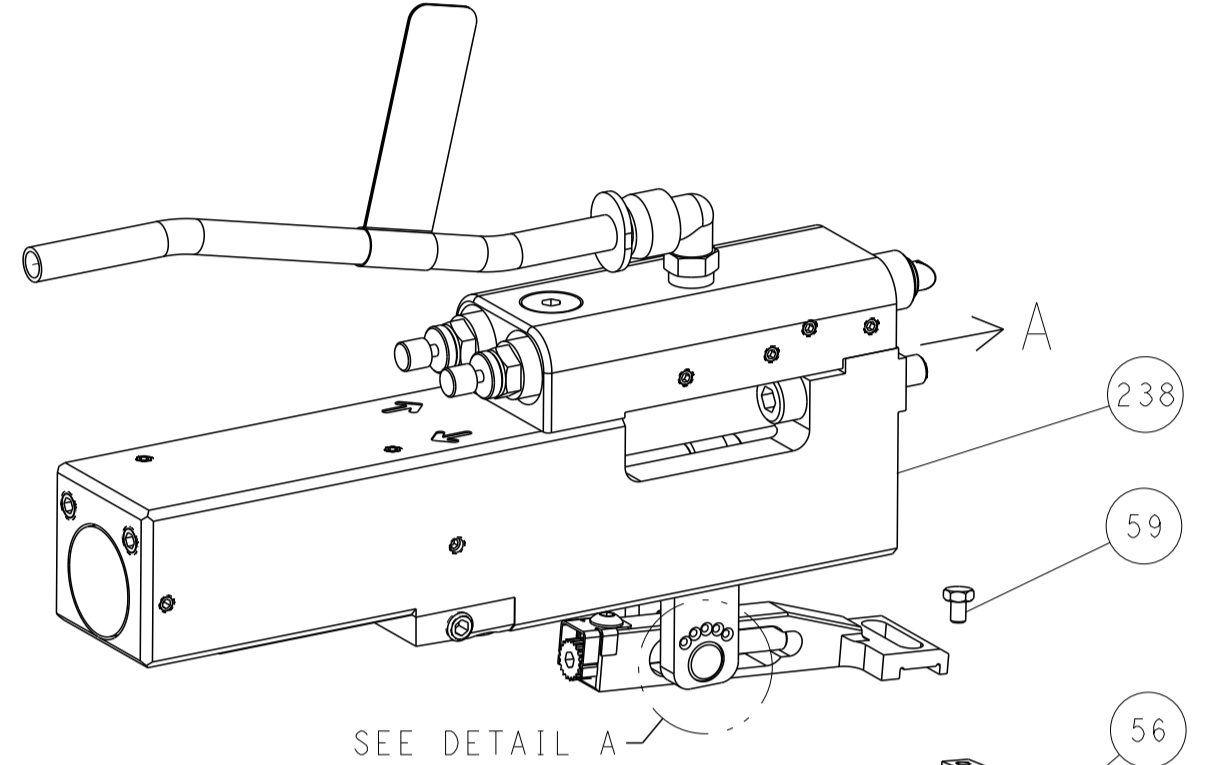

SEE DETAIL A  
 FEED SPRING SETTING POSITION  
 (SHOWN FROM REAR SIDE)

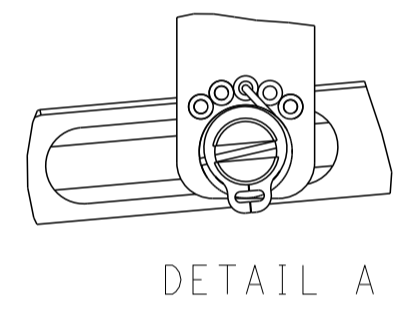

### DOUBLE ACTING PNEUMATIC WITH SENSORS

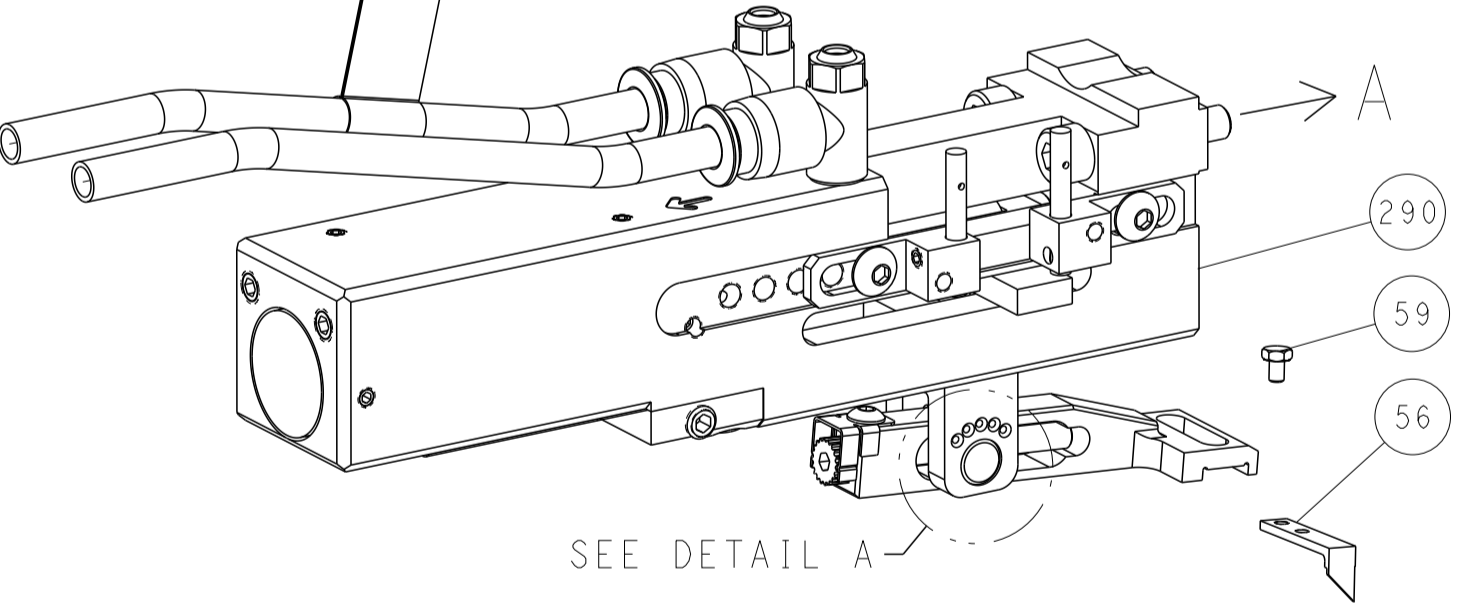

SEE DETAIL A

### CAM POSITIONS

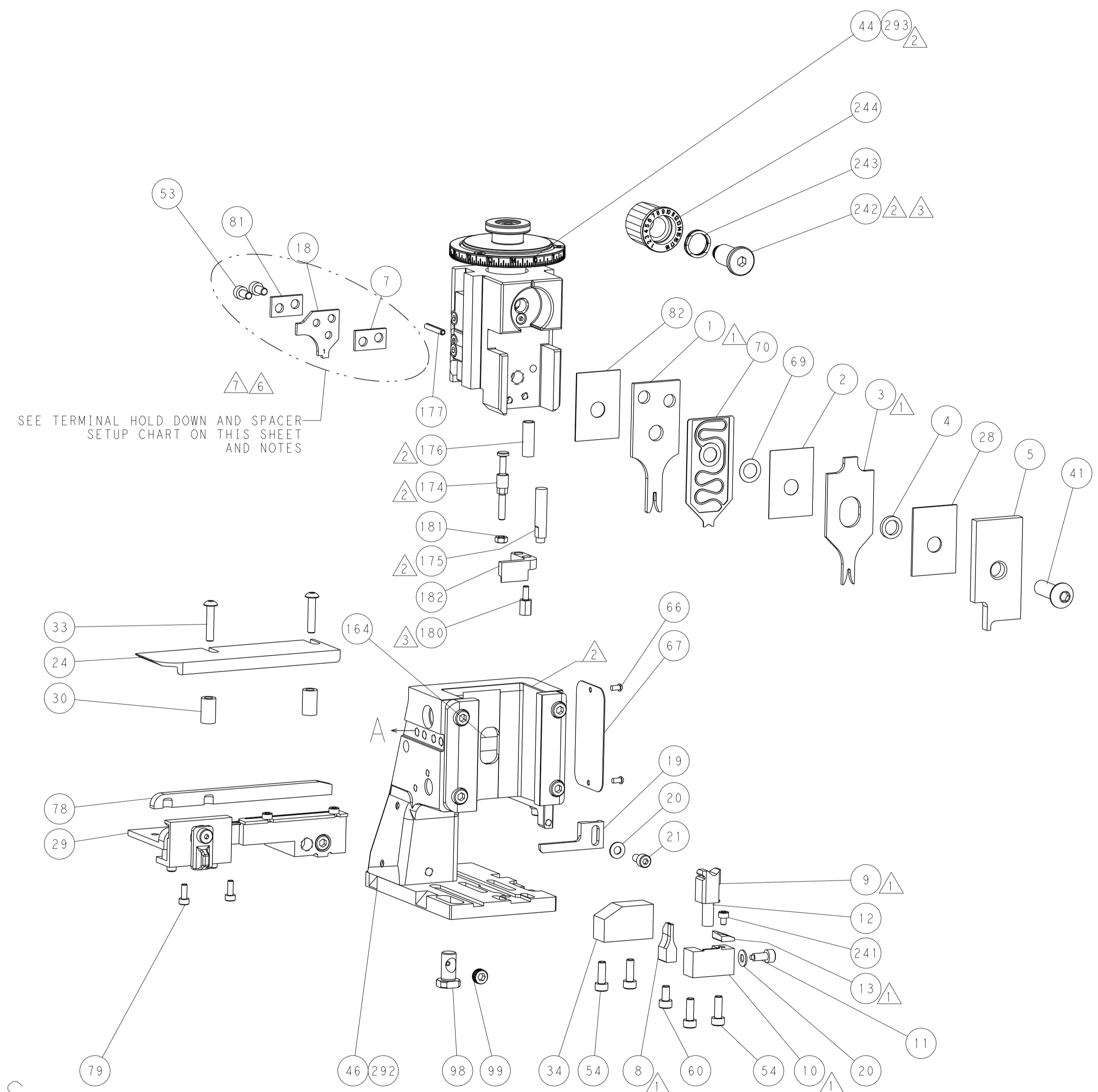
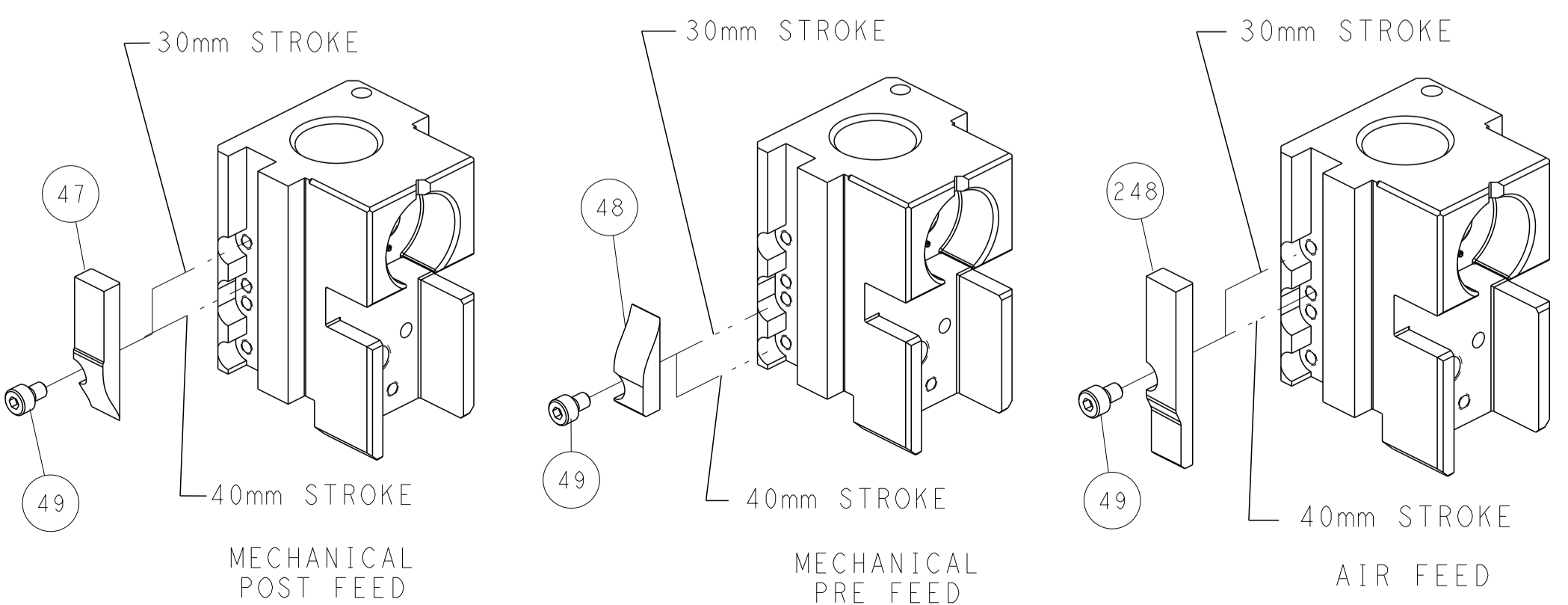

SEE TERMINAL HOLD DOWN AND SPACER SETUP CHART ON THIS SHEET AND NOTES

### TERMINAL HOLD DOWN & SPACER SETUP CHART

GROUP	HOLD DOWN & SPACER TOOLING SETUP FOR TERMINALS:	POSITION
GROUP 1	928999-1 2-928918-2 928999-5 3-928918-2 928999-6 5-928918-1 5-928999-1 6-928918-1 6-928999-5 6-928918-2 928918-1 6-928918-3 928918-2 1394702-1 1-928918-1 1394702-2 1-928918-2 5-1394702-1 5-1394702-2	POSITION 1
	968893-1	POSITION 1
GROUP 2	968220-1 5-968220-6 968220-5 1703296-1 968220-6 1703296-5 5-968220-1 1534116-1 5-968220-5 1534116-2 5-968220-5 5-1534116-1 5-1534116-2	POSITION 2
	1241918-1	POSITION 2

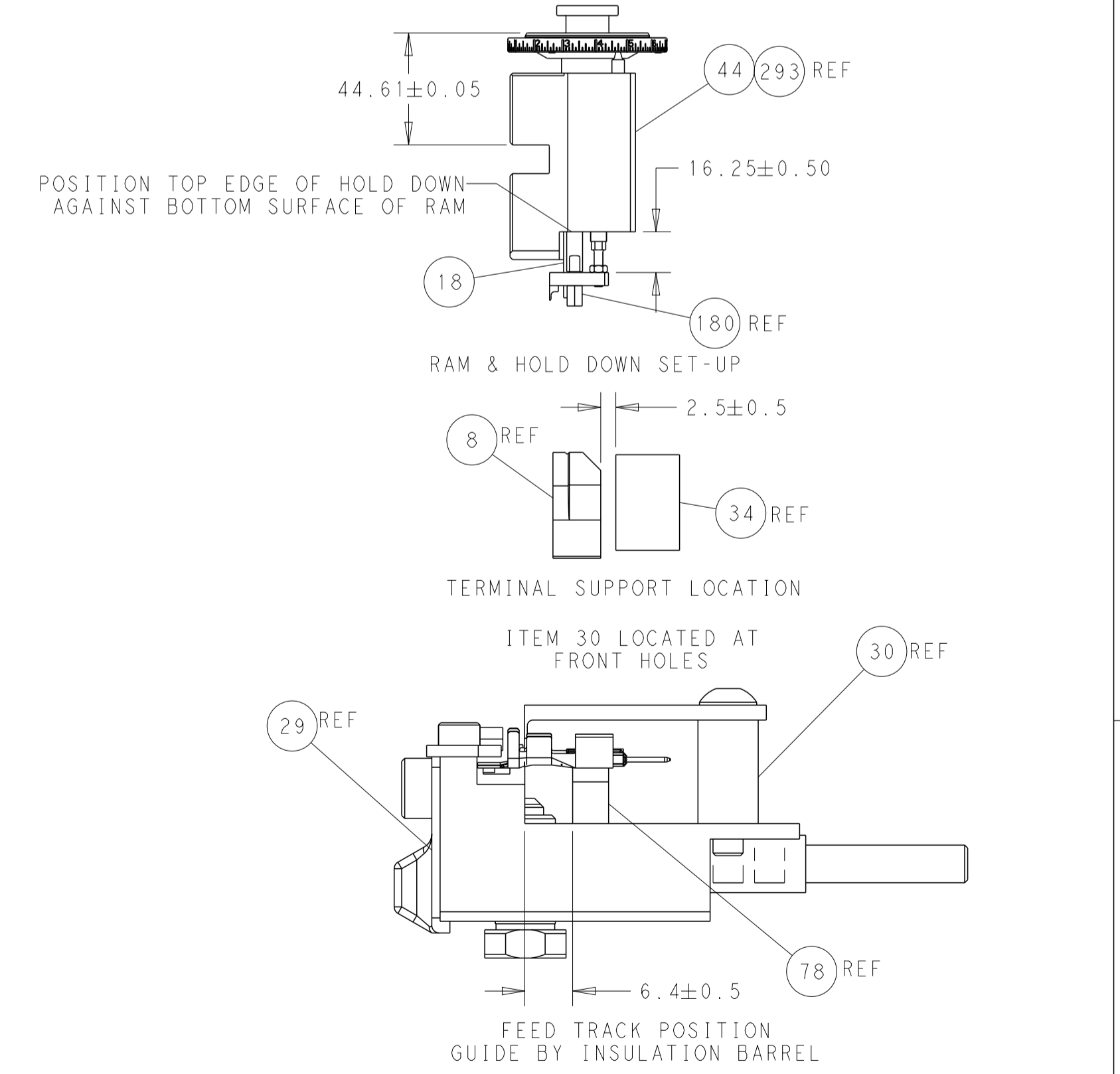

**ATLANTIC VERSION**  
 Shown on sheets 1 of 4 & 2 of 4  
 (Pacific version shown on sheets 3 of 4 & 4 of 4)

DIMENSIONS: mm 		TOLERANCES UNLESS OTHERWISE SPECIFIED: 0 PLC ± 1 PLC ± 3 PLC ± 4 PLC ± ANGLES ±		DWN L.GROSS 02SEP2011 CHK G.BAILLEY 02SEP2011 APVD J.CRUZ 02SEP2011 PRODUCT SPEC APPLICATION SPEC WEIGHT Customer Accessible Production Drawing		NAME Ocean Side Feed Applicator SIZE CAGE CODE DRAWING NO. RESTRICTED TO A1 00779 C=2151493 SCALE 5:1 SHEET 2 OF 4 REV L	
--------------------	--	--	--	---	--	---	--

PART NUMBER	REVISION	DESCRIPTION	FEED TYPE
2-2151493-1	L	FINE CRIMP HEIGHT ADJUST	MECHANICAL
2-2151493-2	L	FINE CRIMP HEIGHT ADJUST	PNEUMATIC
4-2151493-2	L	FINE CRIMP HEIGHT ADJUST	DOUBLE ACTING PNEUMATIC WITH SENSORS
7-2151493-7	A	CRIMP TOOLING KIT	-

PACIFIC VERSION TERMINATOR INTERFACE ADAPTER

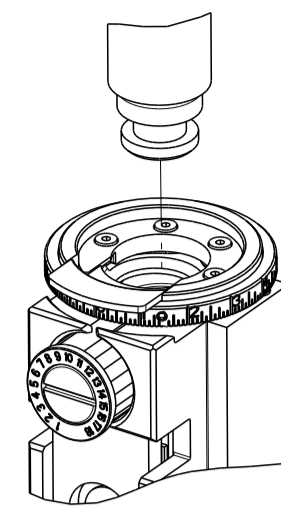

APPLICATOR DATA		
CRIMP	SIZE	TYPE
WIRE	1.40 mm [.055]	F
INSUL	1.83 mm [.072]	O
APPLICATOR INSTRUCTIONS 408-35042		

TERMINAL DATA: TE TERMINAL		TE CRIMP SPECIFICATION	
TERMINAL NAME: MICRO QUADOCK SYSTEM			
WIRE STRIP LENGTH		INSULATION DIAMETER RANGE	
3.45-3.75 mm [.136-.148 IN]		Ø 1.10-1.60 mm [.043-.063 IN]	
TERMINAL APPLICATION SPECIFICATION	(A) 114-18021	-	-
	(B) 114-61024	-	-

TERMINALS APPLIED			
GROUP 1		GROUP 2	
TE TERMINAL	TE TERMINAL	TE TERMINAL	TE TERMINAL
(A) 928999-1	(A) 5-928918-2	(A) 968220-1	(A) 1703296-1
(A) 928999-5	(A) 5-928918-1	(A) 968220-5	(A) 1703296-5
(A) 928999-6	(A) 6-928918-1	(A) 968220-6	(A) 1534116-1
(A) 5-928999-1	(A) 6-928918-2	(A) 5-968220-1	(A) 1534116-2
(A) 968893-1	(A) 6-928918-3	(A) 5-968220-5	(A) 5-1534116-1
(A) 928918-1	(A) 1394702-1	(A) 5-968220-6	(A) 5-1534116-2
(A) 928918-2	(A) 1394702-2	(B) 2005119-1	(A) 1241918-1
(A) 1-928918-1	(A) 5-928999-5		
(A) 1-928918-2	(A) 5-928999-6		
(A) 5-1394702-1	(A) 6-928999-5		
(A) 5-1394702-2	(A) 5-968893-1		

WIRE SIZE	CRIMP HEIGHT mm [INCH]	CRIMP HEIGHT REFERENCE SETTING
0.50mm2	0.86 +/- 0.03 [.034 +/- .001]	9.0
0.35mm2	0.76 +/- 0.03 [.030 +/- .001]	9.9
22 AWG	0.76 +/- 0.03 [.030 +/- .001]	9.9
0.25mm2	0.72 +/- 0.03 [.028 +/- .001]	10.4

- 1 RECOMMENDED SPARE PARTS
- 2 REFER TO SUPPLIED INSTRUCTION SHEET FOR CLEANING, LUBRICATION & STORAGE OF APPLICATOR.
- 3 APPLY PART NUMBER 2-23419-6 LOCTITE TO THREADS OF ITEM 242.
- 4 CRIMP HEIGHT REFERENCE SETTING WAS THE SETTING USED WHEN THE APPLICATOR WAS QUALIFIED AT THE FACTORY. ADJUSTMENT MAY BE NECESSARY WHEN RUNNING APPLICATOR IN THE FIELD.
- 5 REFER TO APPLICATION SPECIFICATION, 114-18021, PAGE 8, NOTE 3 CONCERNING CRIMPING 0.50mm<sup>2</sup> WIRE.
- 6 POSITION THE HOLD DOWN, ITEM 18, IN ORIENTATION 1 FOR GROUP 1 TERMINALS. REFER TO SHEET 4.
- 7 POSITION THE HOLD DOWN, ITEM 18, IN ORIENTATION 2 FOR GROUP 2 TERMINALS. REFER TO SHEET 4.

- 8 THIS CRIMP PARAMETER IS PROVIDED TO MEET A CUSTOM AND UNIQUE CUSTOMER REQUIREMENT. IT HAS BEEN EVALUATED AND IS CONDITIONALLY SPECIFIED BY TE CONNECTIVITY. THIS CUSTOMIZED CRIMP PARAMETER IS NOT LISTED AS AN APPROVED APPLICATION WITHIN A TE CONNECTIVITY APPLICATION SPECIFICATION. **TE CONNECTIVITY EXPRESSLY DISCLAIMS ANY AND ALL WARRANTIES THAT THE PRODUCT WILL PERFORM SIMILARLY TO VALIDATED AND APPROVED APPLICATIONS, AS STATED WITHIN TE CONNECTIVITY APPLICATION SPECIFICATIONS, INCLUDING BUT NOT LIMITED TO IMPLIED WARRANTIES OF MERCHANTABILITY OR FITNESS FOR PARTICULAR PURPOSE.** AS SUCH, IT IS HIGHLY RECOMMENDED THAT THE CUSTOMER PERFORM FURTHER DETAILED EVALUATION TO ASSESS PRODUCT PERFORMANCE IN THE SPECIFIC APPLICATION.
- 9. UNLESS SPECIFIED OTHERWISE TORQUE VALUES SHALL BE USED PER DOCUMENT, 101-35000.
- 10 THIS APPLICATOR IS EQUIPPED WITH THE DOUBLE ACTING FEED WITH SENSORS AND IS APPLICATION SPECIFIC. IT DOES NOT REQUIRE ITEMS 49 & 151.

ENTRY LEVEL APPLICATOR		ITEM SUBSTITUTION LIST		
PART NUMBER	SAME AS	ITEM	ITEM DESCRIPTION	SUBSTITUTE PART NUMBER
8-2151493-1	2151493-1	1	WIRE CRIMPER	1-1803529-5
8-2151493-2	2151493-2	3	INSULATION CRIMPER	1803604-2
9-2151493-1	2-2151493-1	46	BASIC SUB -ASSEMBLY	1803940-9
9-2151493-2	2-2151493-2	141	BASIC SUB -ASSEMBLY	1-1803940-0
			LUBRICATOR	DELETE

**PACIFIC VERSION**  
Shown on sheets 3 of 4 & 4 of 4  
(Atlantic version shown on sheets 1 of 4 & 2 of 4)

LOC	DIST	REVISIONS					
A	66	P	LTN	DESCRIPTION	DATE	OWN	APVD
		-	-	SEE SHEET 1	-	-	-

-	1	-	-	2844950-1	AIR FEED MODULE		290
-	1	1	1	2119082-5	CAM, SNAIL, INSULATION ADJUSTMENT		244
-	1	1	1	2079764-1	WASHER, WAVE SPRING, CREST-TO-CREST		243
-	1	1	1	2119083-1	RETAINER, INSULATION DIAL		242
-	1	1	1	7-18023-7	SCR, SKT HD CAP M3 X 4.0		241
-	-	-	1	2119580-1	MECHANICAL FEED ASSEMBLY		239
-	-	-	1	2844940-1	AIR FEED MODULE		238
-	REF	REF	REF	994970-2	COUNTER, MAGNETIC		164
-	-	1	-	2119641-2	FEED CAM, AIR FEED		151
-	1	1	1	2168083-8	SCR, SKT HD CAP, RoHS, M4 X 16		144
-	4	4	4	2168083-9	SCR, SKT HD CAP, RoHS, M4 X 20		143
-	-	-	1	2119653-2	FEED CAM, POST FEED		142
-	1	1	1	1-1803583-0	APPLICATOR BASIC ASSEMBLY, SF		141
-	1	1	1	1803516-1	RAM ASSEMBLY, SF PACIFIC		140
-	1	1	1	2844908-1	SCREW, LOCKING		99
-	1	1	1	2844907-1	POST, LOCKING		98
-	1	1	1	455888-5	SPACER, CRIMPER		82
-	1	1	1	1-240641-3	SPACER		81
-	2	2	2	2168083-1	SCR, SKT HD CAP, RoHS, M3 X 8.0		79
-	1	1	1	1633782-2	FENCE		78
-	1	1	1	1803607-3	DOCUMENTATION PACKAGE		71
-	1	1	1	2119791-5	DEPRESSOR, WIRE		70
-	1	1	1	2119943-1	WASHER, SPACER		69
-	1	1	1	2119740-1	TAG IDENTIFICATION		67
-	2	2	2	2168078-1	SCREW, DRIVE, RH, RoHS, 2 x .188		66
-	1	1	1	5-18022-5	SCR, HEX HD CAP, M4 X 6.0		59
-	1	1	1	1338685-1	PAWL, FEED		56
-	2	2	2	2168083-2	SCR, SKT HD CAP, RoHS, M4 X 8.0		53
-	-	1	2	18023-9	SCR, SKT HD CAP M4 X 6.0		49
-	-	-	1	2119652-1	FEED CAM, PRE FEED		48
-	1	1	1	1803602-1	SCR, BHSC, RoHS (M8 X 25)		41
-	1	1	1	1752356-6	SUPPORT, TERMINAL		34
-	2	2	2	2079383-5	SCR, BHSC, RoHS (M4 X 20)		33
-	2	2	2	2-2844962-4	SPACER, CYLINDRICAL, STRIP GUIDE		30
-	1	1	1	2844992-1	ASSEMBLY, STRIP GUIDE		29
-	1	1	1	1-455888-0	SPACER, CRIMPER		28
-	1	1	1	1320928-2	STRIP GUIDE		24
-	1	1	1	2168083-2	SCR, SKT HD CAP, RoHS, M4 X 8.0		21
-	2	2	2	1-18028-2	WASHER, FLAT, REG M4		20
-	1	1	1	2119533-1	STRIPPER, SIDE FEED		19
-	1	1	1	1803155-1	HOLD DOWN, TERMINAL		18
-	1	1	1	2119806-1	INSERT, SHEAR		13
-	1	1	1	3-22280-3	SPRING, COMPRESSION		12
-	1	1	1	1-356885-4	STOP, SHEAR		11
-	1	1	1	2119805-1	SHEAR HOLDER, FRONT		10
-	1	1	1	1803095-1	FLOATING SHEAR, FRONT		9
-	1	1	1	1-1338690-2	ANVIL, COMBINATION .055		8
-	1	1	1	4-240641-2	SPACER		7
-	1	1	1	2119757-4	DEPRESSOR, SHEAR		5
-	1	1	1	238011-8	BLOCK, CRIMPER SPACER		4
-	1	1	1	2119784-2	CRIMPER, INSULATION O PREMIUM		3
-	1	1	1	455888-1	SPACER, CRIMPER		2
-	1	1	1	1-562108-5	CRIMPER, WIRE, F		1

DIMENSIONS:		TOLERANCES UNLESS OTHERWISE SPECIFIED:		MATERIAL:		FINISH:		WEIGHT:		SCALE:	
mm	0 PLC ±	1 PLC ±	2 PLC ±	3 PLC ±	4 PLC ±	ANGLES	FINISH				
Customer Accessible Production Drawing		SCALE 5:1		SHEET 3 OF 4		REV L					

LOC	DIST	REVISIONS			
A	66	REV	DATE	BY	APPV
-	-	SEE SHEET 1	-	-	-

# FEED TYPE MECHANICAL

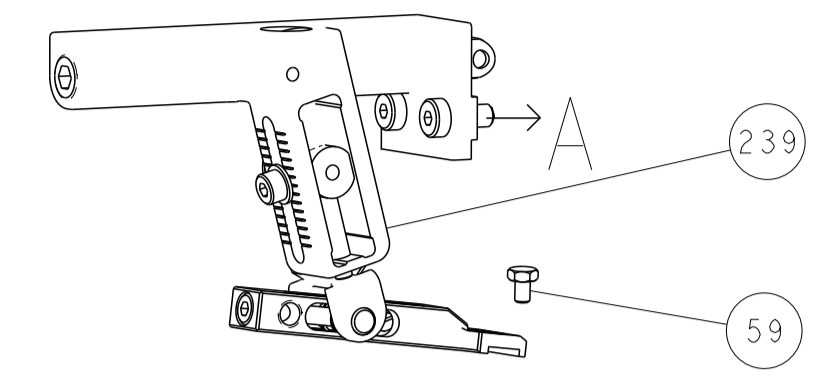

# PNEUMATIC

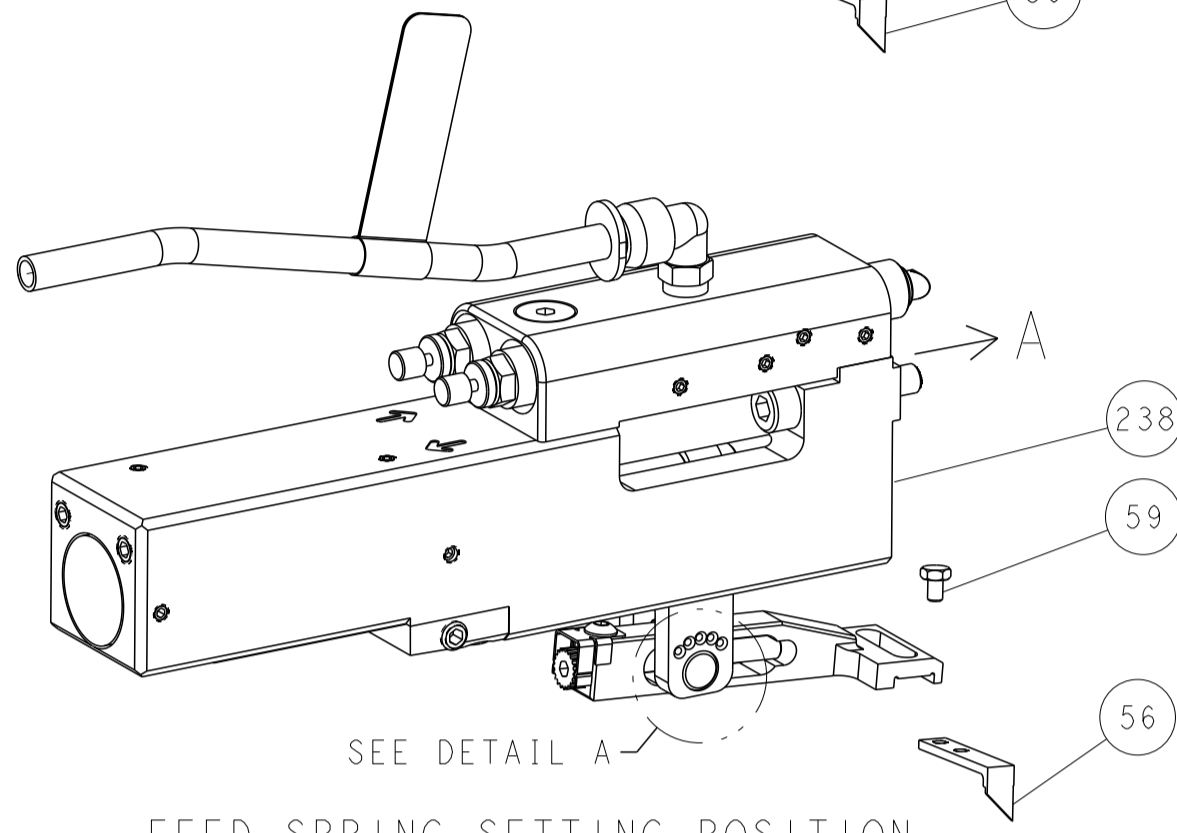

SEE DETAIL A  
FEED SPRING SETTING POSITION (SHOWN FROM REAR SIDE)

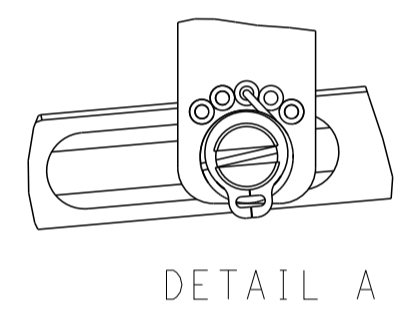

DETAIL A

# DOUBLE ACTING PNEUMATIC WITH SENSORS

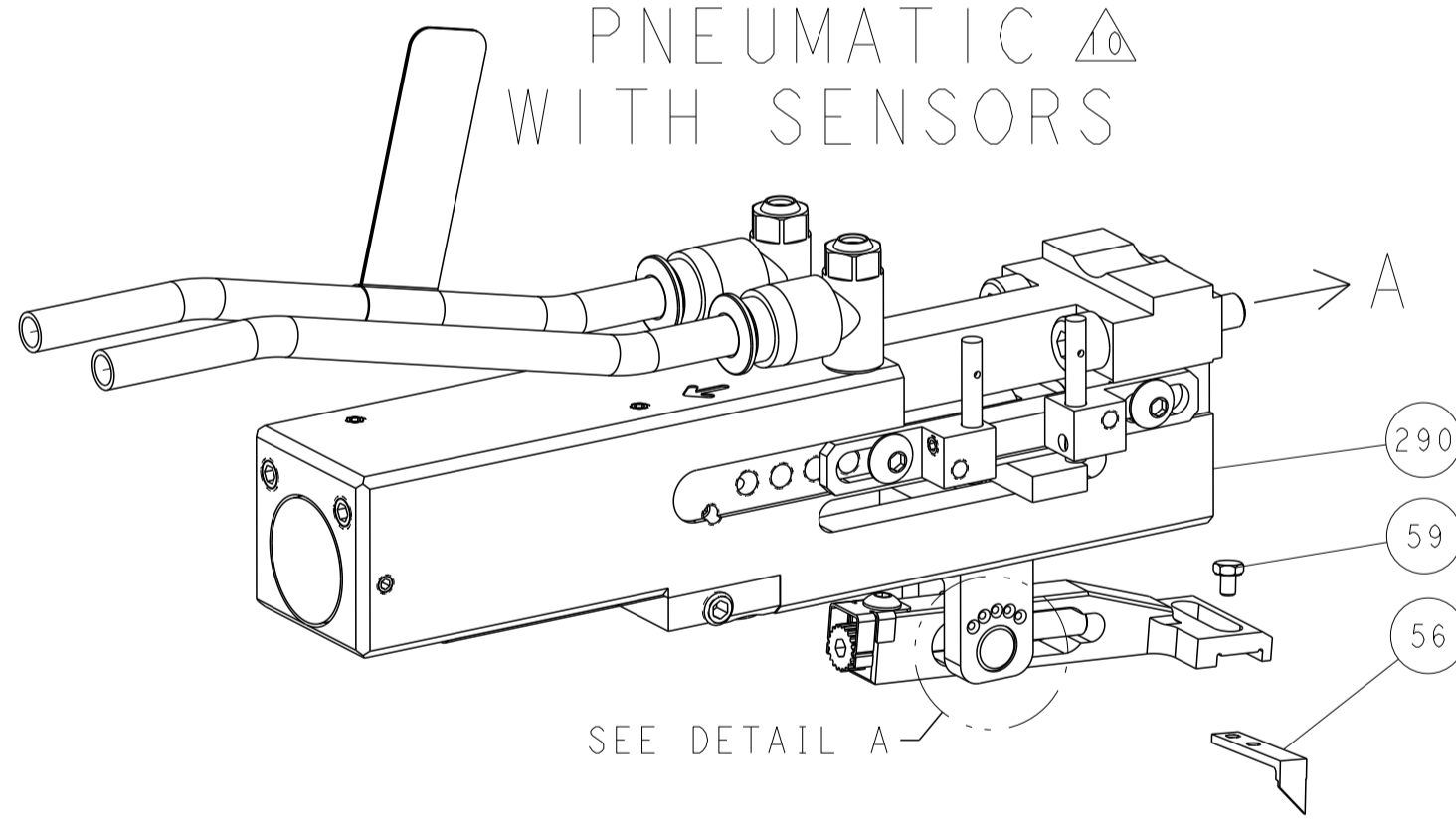

SEE DETAIL A

# CAM POSITIONS

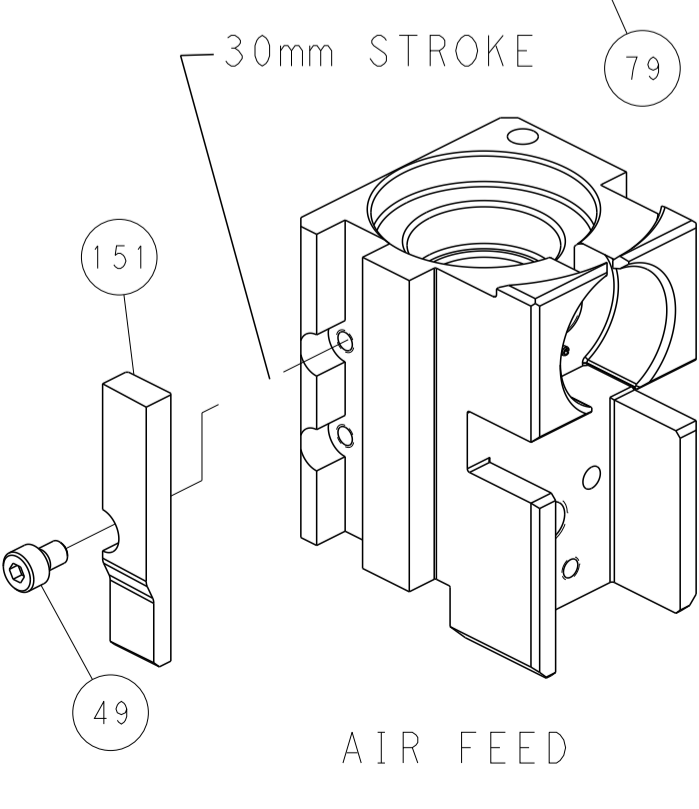
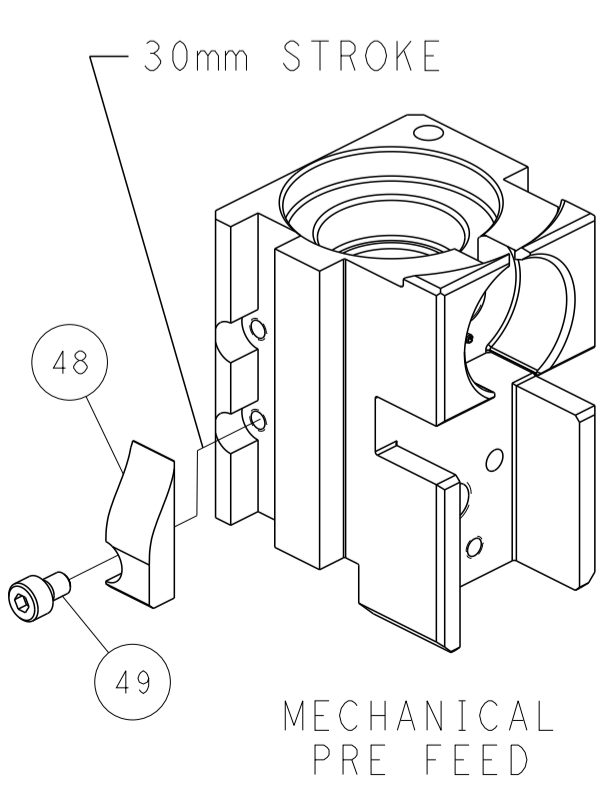
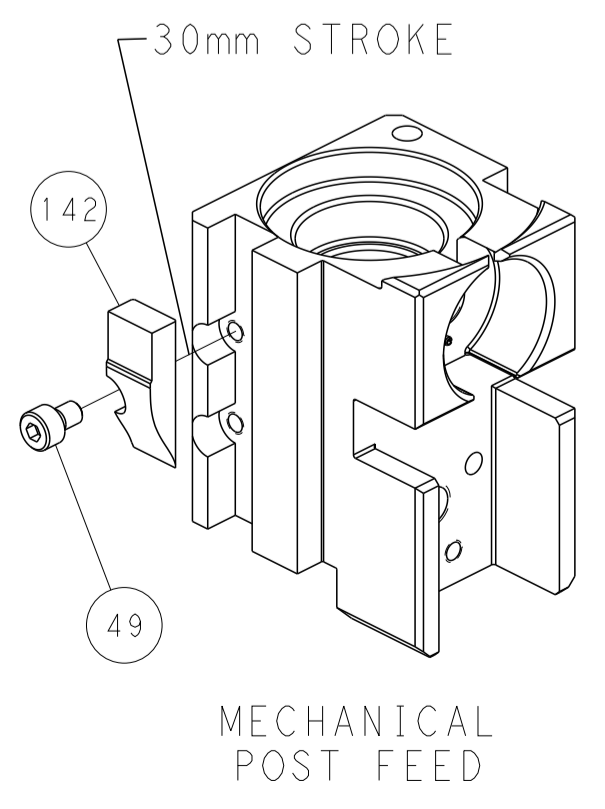

SEE TERMINAL HOLD DOWN AND SPACER SETUP CHART ON THIS SHEET AND NOTES

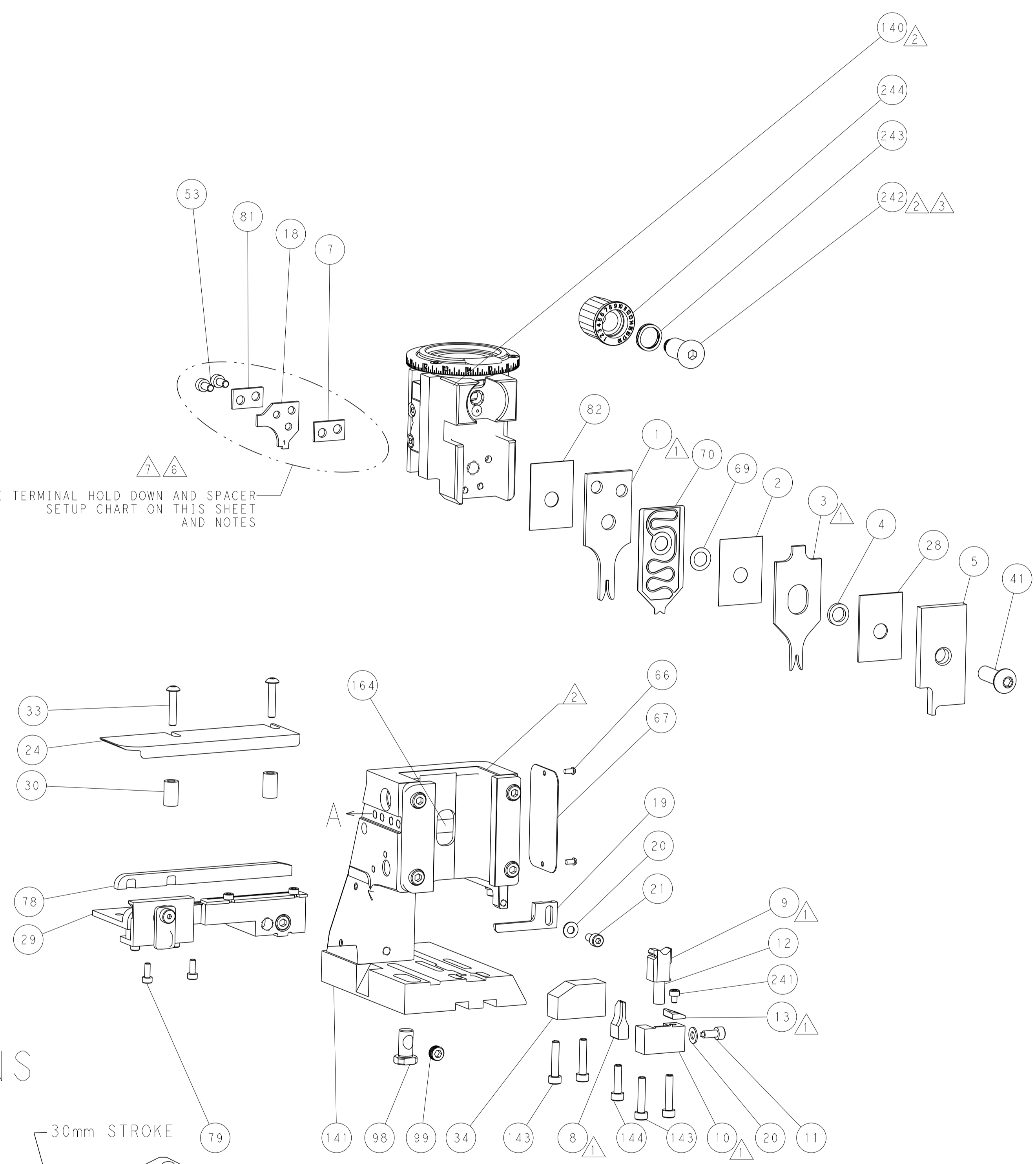

## TERMINAL HOLD DOWN AND SPACER SETUP CHART

GROUP	HOLD DOWN & SPACER TOOLING SETUP FOR TERMINALS:	POSITION
GROUP 1	928999-1 2-928918-2 928999-5 3-928918-2 928999-6 5-928918-1 5-928999-1 6-928918-1 6-928999-5 6-928918-2 928918-1 6-928918-3 928918-2 1394702-1 1-928918-1 1394702-2 1-928918-2 5-1394702-1 5-1394702-2	POSITION 1
GROUP 2	968220-1 5-968220-6 968220-5 1703296-1 968220-6 1703296-5 5-968220-1 1534116-1 5-968220-5 1534116-2 5-1534116-1 5-1534116-2	POSITION 2
GROUP 2	1241918-1	POSITION 2

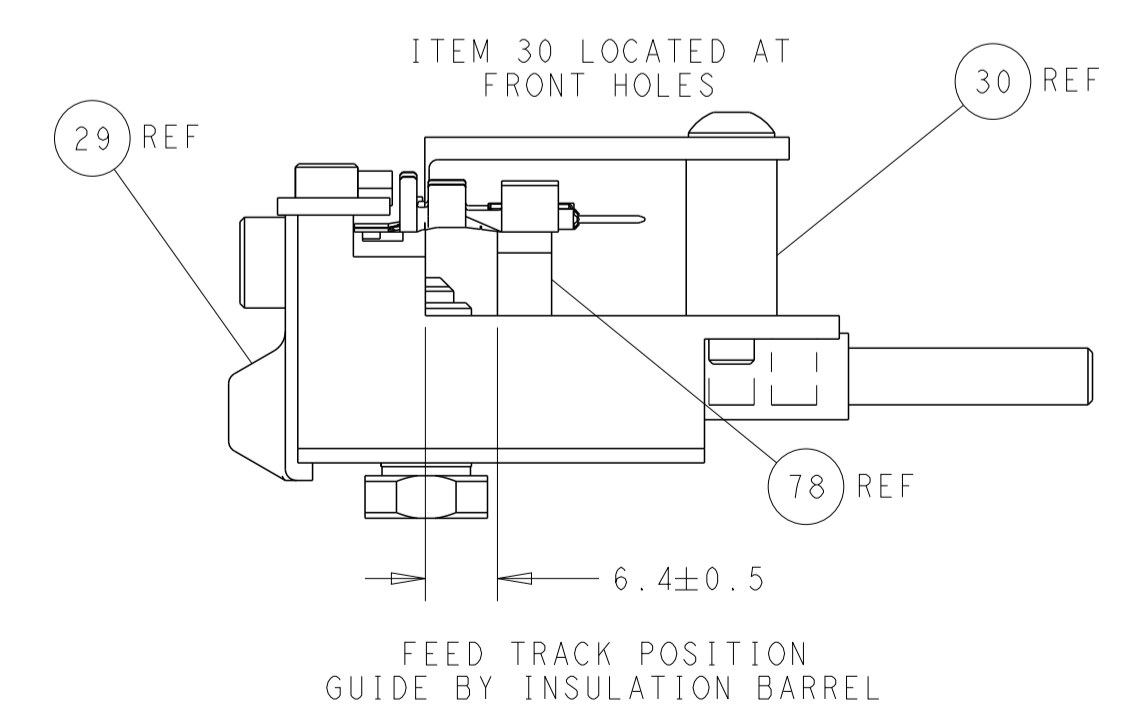
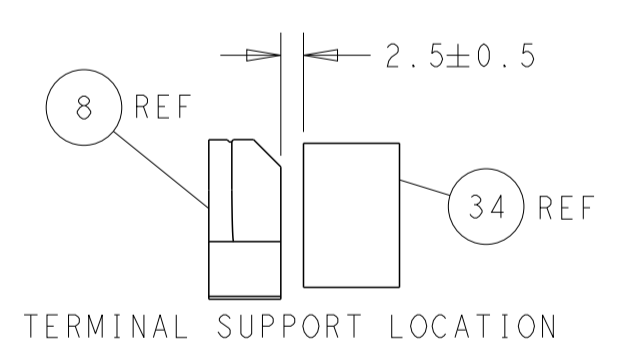
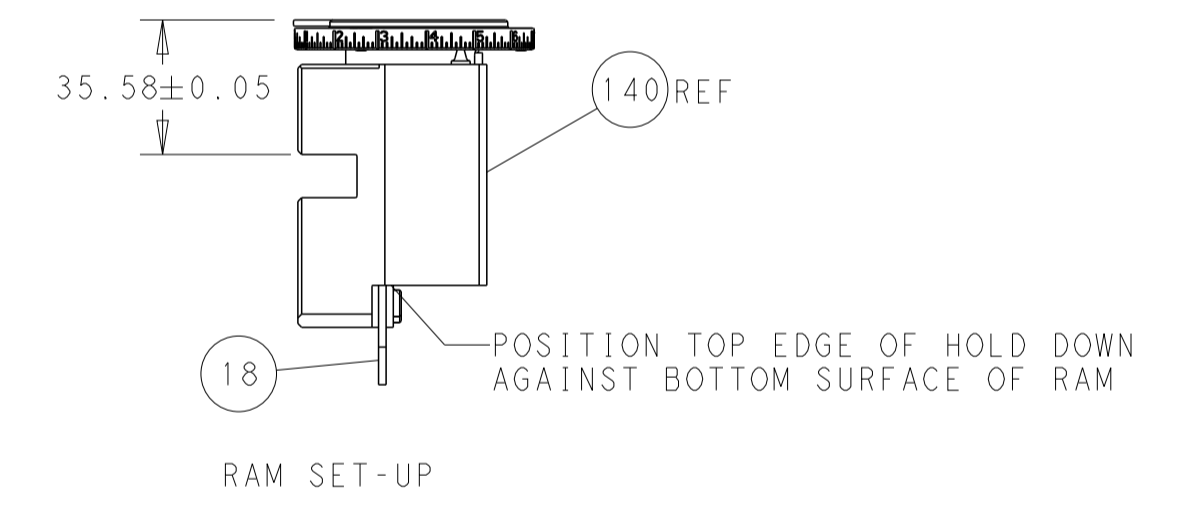

**PACIFIC VERSION**  
 Shown on sheets 3 of 4 & 4 of 4  
 (Atlantic version shown on sheets 1 of 4 & 2 of 4)

DIMENSIONS: mm 		TOLERANCES UNLESS OTHERWISE SPECIFIED: 0 PLC ± 1 PLC ± 3 PLC ± 4 PLC ± ANGLES ± FINISH		DWN L.GROSS 02SEP2011 CHK G.BAILEY 02SEP2011 APVD J.CRUZ 02SEP2011 PRODUCT SPEC APPLICATION SPEC WEIGHT Customer Accessible Production Drawing		NAME Ocean Side Feed Applicator SIZE CAGE CODE DRAWING NO A1 00779 C=2151493 SCALE 5:1 SHEET 4 OF 4 REV L	
--------------------	--	--	--	--	--	--	--