

THIS DRAWING IS UNPUBLISHED. RELEASED FOR PUBLICATION
 © COPYRIGHT - By - ALL RIGHTS RESERVED.

LOC	DIST	REVISIONS					
00	00	P	LTR	DESCRIPTION	DATE	DWN	APVD
		B1		REVISED PER ECO-11-005150	21MAR11	RK	HMR

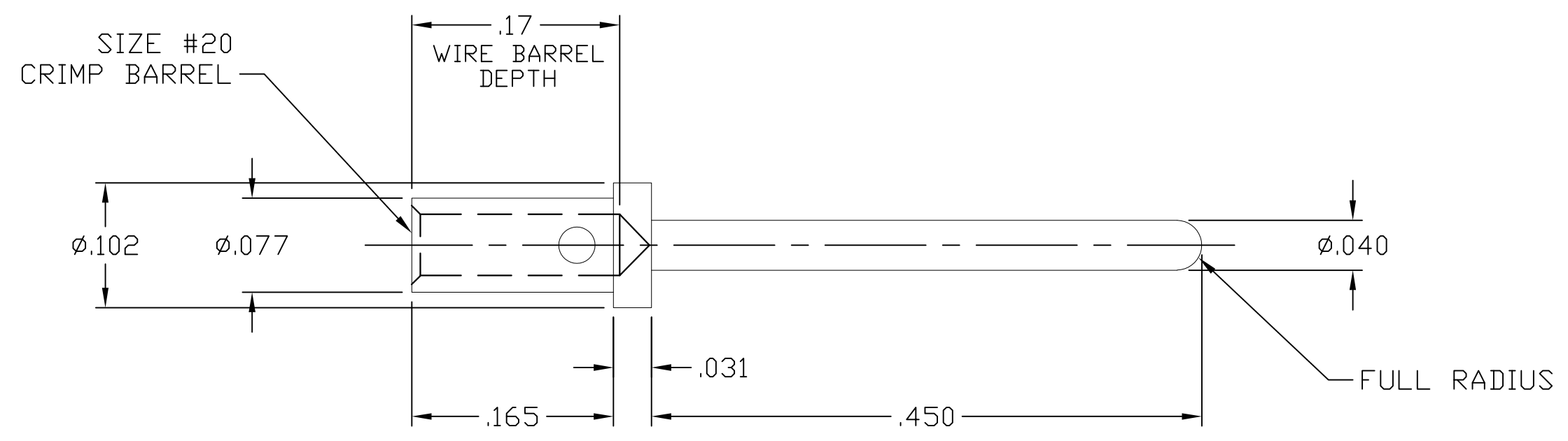

6. FOR TERMINATION, USE FOLLOWING EQUIPMENT:
 SHOWN FOR REFERENCE ONLY (USER SUPPLIED)
 CRIMP TOOL: M22520/1-01
 TURRET HEAD/LOCATOR: M22520/1-02

5 FINISH: GOLD PLATED, .000030 MIN THICK
 OVER NICKEL PLATED, .000050 MIN THICK
 4 FINISH: GOLD PLATED, .000010 MIN THICK
 OVER NICKEL PLATED, .000050 MIN THICK

3. MATERIAL: COPPER ALLOY.
 2. ITEMS PROVIDED TO THIS SPECIFICATION SHALL BE IDENTIFIED ON THE CONTAINER WITH THE FOLLOWING INFORMATION:
 PART NUMBER & DATE CODE OF MANUFACTURE.
 1. PART NUMBER CHANGES AND OR DESIGN CHANGES AFFECTING ITEM INTERCHANGEABILITY REQUIRE PRIOR TE CONNECTIVITY APPROVAL AND AUTHORIZATION BY REVISION TO THIS DRAWING.

NOTES: UNLESS OTHERWISE SPECIFIED

1650155-2	5
1650155-1	4
PART NUMBER	DESCRIPTION

THIS DRAWING IS A CONTROLLED DOCUMENT.		DWN J. PATTERSON 11JULY07	TE Connectivity	
DIMENSIONS: INCHES		CHK D. ORRIS 11JULY07		
TOLERANCES UNLESS OTHERWISE SPECIFIED:		APVD D. ORRIS D. ORRIS	NAME CONTACT, PIN, SIZE #20 CRIMP, STANDARD, .33 PIN EXT	
0 PLC ± - 1 PLC ± - 2 PLC ± .02 [.3] 3 PLC ± .010 [.25] 4 PLC ± - ANGLES ± .5°		PRODUCT SPEC -	SIZE A3	
MATERIAL SEE NOTE 1, SHEET 1		FINISH -	APPLICATION SPEC -	CAGE CODE 00779
		WEIGHT -	DRAWING NO C-1650155	RESTRICTED TO -
CUSTOMER DRAWING			SCALE 8=1	SHEET 1 OF 1
			REV B1	