

Type FCC / FCC-P Fast Acting Ceramic Fuse 5 x 20 mm



www.optifuse.com

(619) 593-5050

Part number:
FCC-XXA or
FCC-P-XXA

Where XX is Amperage
P is for Pigtail version

Agency Standards and Listings:



Approvals:

UL Listed 250mA-15A
CSA Certified 250mA-12A
CSA Acceptance 15A
PSE 6.3A-15A

Time Characteristic

Rated Current	1 In	1.35 In	2 In
	MIN	MAX	MAX
10mA~20A	4 Hrs	1 Hr	30 Sec

Interrupt Ratings:

10mA~15A: 10,000 amperes at 125VAC
10mA~1A: 35 amperes at 250VAC
1.25A~3.5A: 100 amperes at 250VAC
3.75A~10A: 200 amperes at 250VAC
10.1A~15A: 750 amperes at 250VAC

Operating Temperature:

-55°C to +125°C

Physical Specifications:

Materials:

Ceramic body / Nickel Plated Brass Caps
Lead Wire:
Diameter Ø0.8 mm 14A and less.
Diameter Ø1.0 mm for rating above 15A to 19A.
Diameter Ø1.2 mm for rating above 20A.

Mechanical Dimensions:

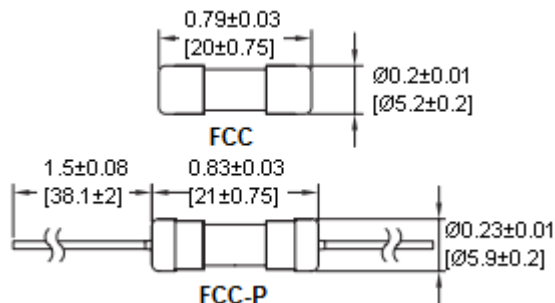

Cartridge Part Number.	Axial Lead Part Number	Ampere Rating (In)	Voltage Rating (V)	Nominal Resistance Cold Ohms	Nominal Melting I ² t A ² Sec
FCC-250mA	FCC-P-250mA	250mA	250V	2.5440	0.0142
FCC-315mA	FCC-P-315mA	315mA		2.0080	0.0218
FCC-400mA	FCC-P-400mA	400mA		0.6030	0.0561
FCC-500mA	FCC-P-500mA	500mA		0.4005	0.1170
FCC-630mA	FCC-P-630mA	630mA		0.2920	0.1715
FCC-750mA	FCC-P-750mA	750mA		0.2144	0.2430
FCC-800mA	FCC-P-800mA	800mA		0.2100	0.2840
FCC-1A	FCC-P-1A	1A		0.1637	0.4140
FCC-1.25A	FCC-P-1.25A	1.25A		*	*
FCC-1.5A	FCC-P-1.5A	1.5A		0.0813	1.4580
FCC-1.6A	FCC-P-1.6A	1.6A		*	*
FCC-2A	FCC-P-2A	2A		0.0576	3.1680
FCC-2.5A	FCC-P-2.5A	2.5A		0.0569	3.6000
FCC-3.15A	FCC-P-3.15A	3.15A		0.0461	5.8725
FCC-4A	FCC-P-4A	4A		0.0275	13.683
FCC-5A	FCC-P-5A	5A		0.0209	22.303
FCC-6.3A	FCC-P-6.3A	6.3A		0.0129	48.237
FCC-7A	FCC-P-7A	7A		0.0127	60.523
FCC-8A	FCC-P-8A	8A		0.0124	95.715
FCC-10A	FCC-P-10A	10A		0.0074	166.10
FCC-12A	FCC-P-12A	12A	0.0057	240.62	
FCC-15A	FCC-P-15A	15A	0.0044	435.98	
FCC-20A	FCC-P-20A	20A	0.0034	792.00	

* Please contact Optifuse

Packaging :

- In Bulk: FCC – 1,000 pcs
FCC-P – 500 pcs per box.
- On Axial Tape & Reel: 1,000 pcs per reel.
- Tape & Reel specification: Per EIA-296-E & IEC 286-1 @ 10mm Pitch and 56.5mm inside Tape spacing.

Type FCC / FCC-P
Fast Acting Ceramic Fuse
5 x 20 mm



www.optifuse.com

(619) 593-5050

PART NUMBER FCC/FCC-P
TIME CURRENT CURVES

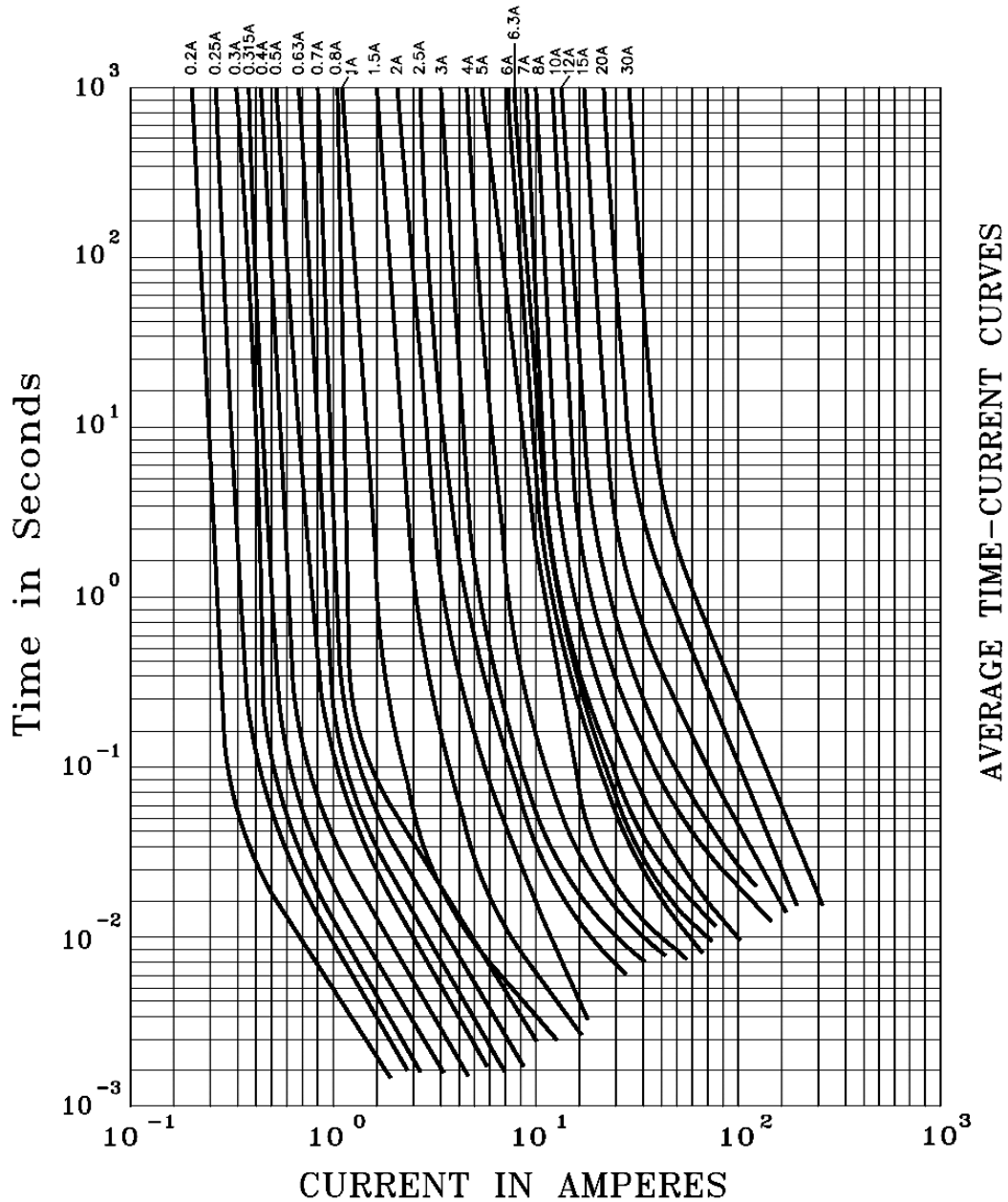

	<p>Warning:</p> <ul style="list-style-type: none"> -Operation beyond the specified maximum ratings or improper use may result in damage and possible electrical arcing and/or flame.
	<ul style="list-style-type: none"> -Avoid contact of fuse with chemical solvent. Prolonged contact may damage the device performance.