

# INTEGRATED CONNECTOR MODULES

0833-2X4R-55-F Power over Ethernet MagJack® 2 x 4



## ELECTRICAL CHARACTERISTICS @ 25°C

TURNS RATIO OCL @ 0.1V, 100KHz 8mA DC BIAS INSERTION LOSS 100KHz TO 100MHz RETURN LOSS (MIN.) 2MHz-30MHz 60MHz-80MHz LEAKAGE INDUCTANCE PRIMARY w/ SECONDARY SHORTED D.C. RESISTANCE (9-8)=(7-6) (RJ1-RJ2)=(RJ3-RJ6) INTERWINDING CAPACITANCE PER CHANNEL (PRI. to SEC.) XTALK 100KHz TO 100MHz HIPOT	1CT : 1CT ±2% 350µH MIN. -1.5 dB MAX. 16 dB MIN. 10 dB MIN. 0.25µH MAX. @ 1MHz 1.4 ΩH . 1.0 ΩH . 40 pF MAX. -30 dB MIN. 2250 VDC
--	--

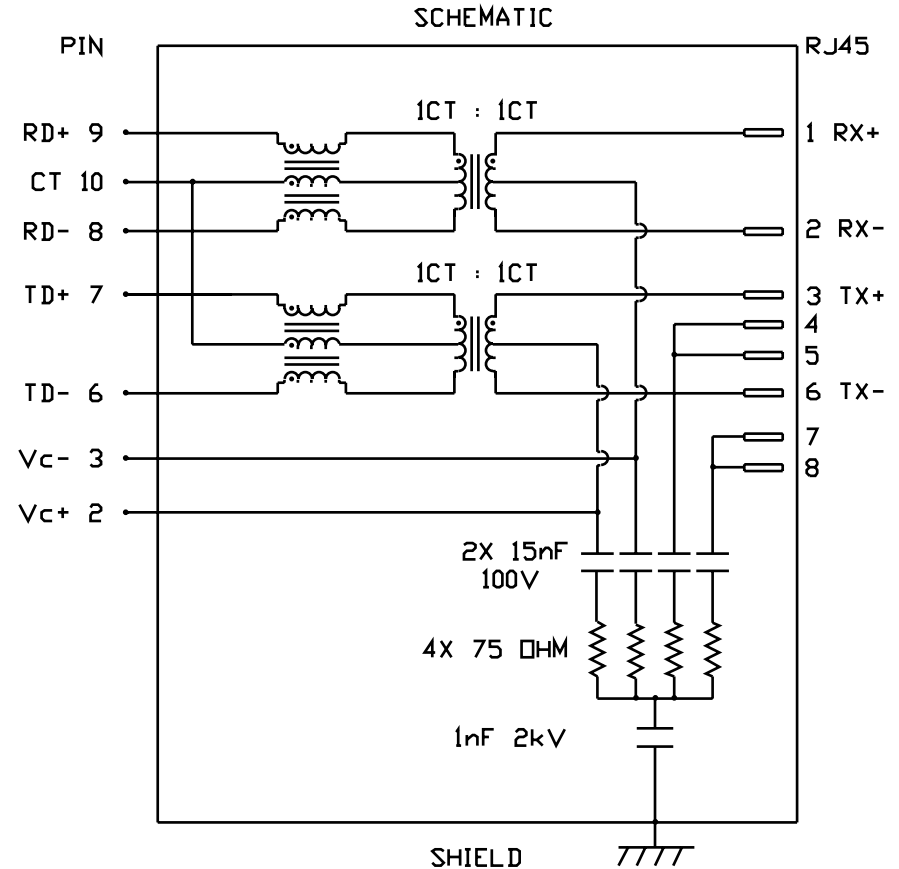

# INTEGRATED CONNECTOR MODULES

0833-2X4R-55-F Power over Ethernet MagJack® 2 x 4

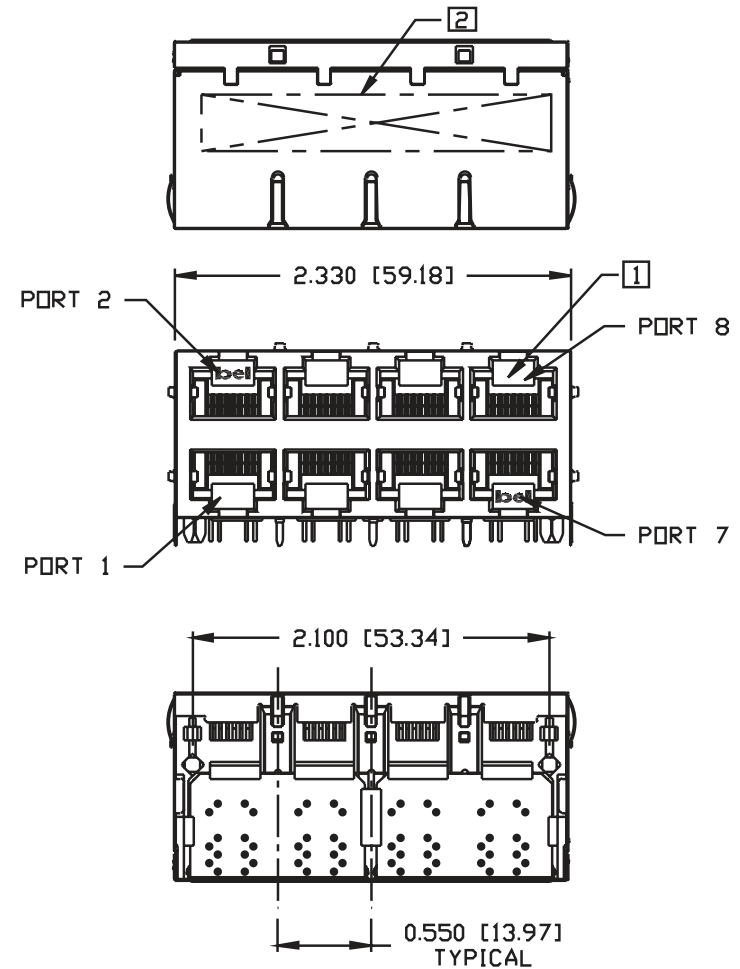
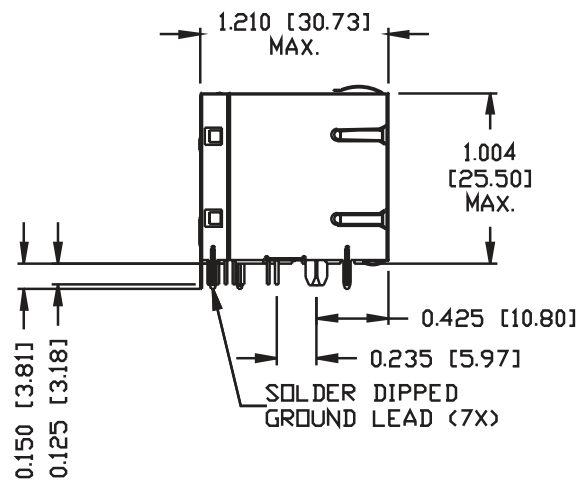

**NOTES:**

- PLASTIC HOUSING: THERMOPLASTIC PA 4/6  
FLAMMABILITY RATING UL 94V-0
- CONTACT PLATING: 50 MICRO-INCH HARD GOLD PLATING
- OUTPUT PINS: TIN-COATED COPPER WIRE, DIA 0.018 INCH.
- SOLDERABILITY: PER MIL STD. 202, METHOD 208.
- METAL SHIELD: NICKEL PLATED COPPER ALLOY.  
(ALL GROUND LEADS ARE SOLDER DIPPED)

- 1. JACK CAVITY CONFORMS TO FCC RULES AND REGULATIONS, PART 68 SUBPART F.
- 2. MARK PART WITH MFG LOGO, MFG NAME, PART NUMBER, AND DATE CODE.
- 3. RoHS COMPLIANCE, PER EU DIRECTIVE 2002/95/EC.

# INTEGRATED CONNECTOR MODULES

0833-2X4R-55-F Power over Ethernet MagJack® 2 x 4

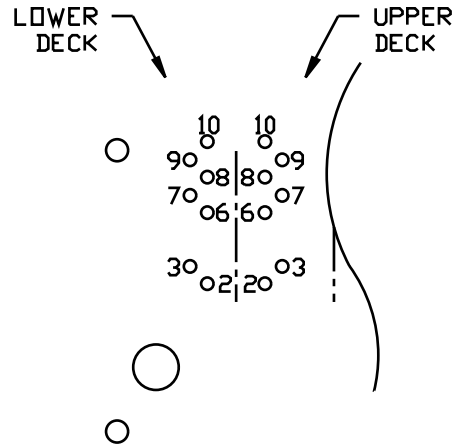

PIN-OUT INFORMATION  
(COMPONENT SIDE VIEW)

10	COMMON CT
9	RD+
8	RD-
7	TD+
6	TD-
5	NO PIN
4	NO PIN
3	Vc-
2	Vc+
1	NO PIN

UNUSED PIN LOCATIONS MUST BE REMOVED TO ENSURE 2KV ISOLATION.

PORT ASSIGNMENT  
(COMPONENT SIDE VIEW)

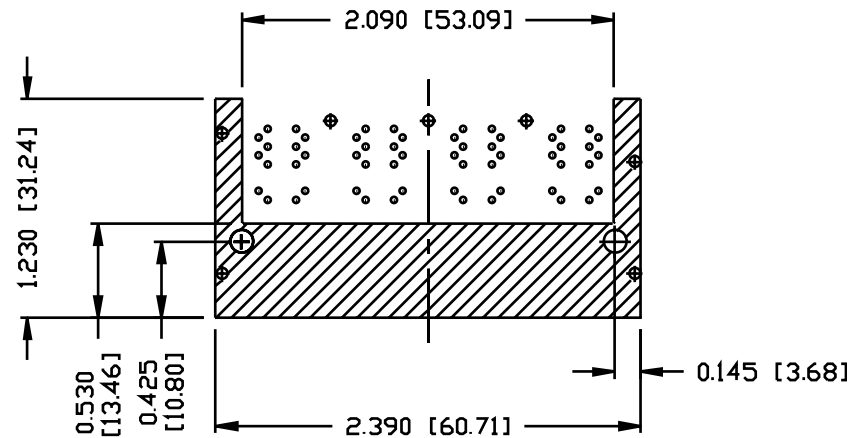
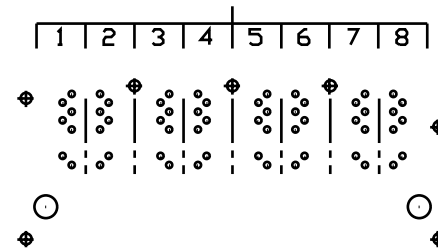

THE SHADED AREA OF BOTTOM SIDE OF PART MAY BE COVERED BY METAL SHIELD.

# INTEGRATED CONNECTOR MODULES

0833-2X4R-55-F Power over Ethernet MagJack® 2 x 4

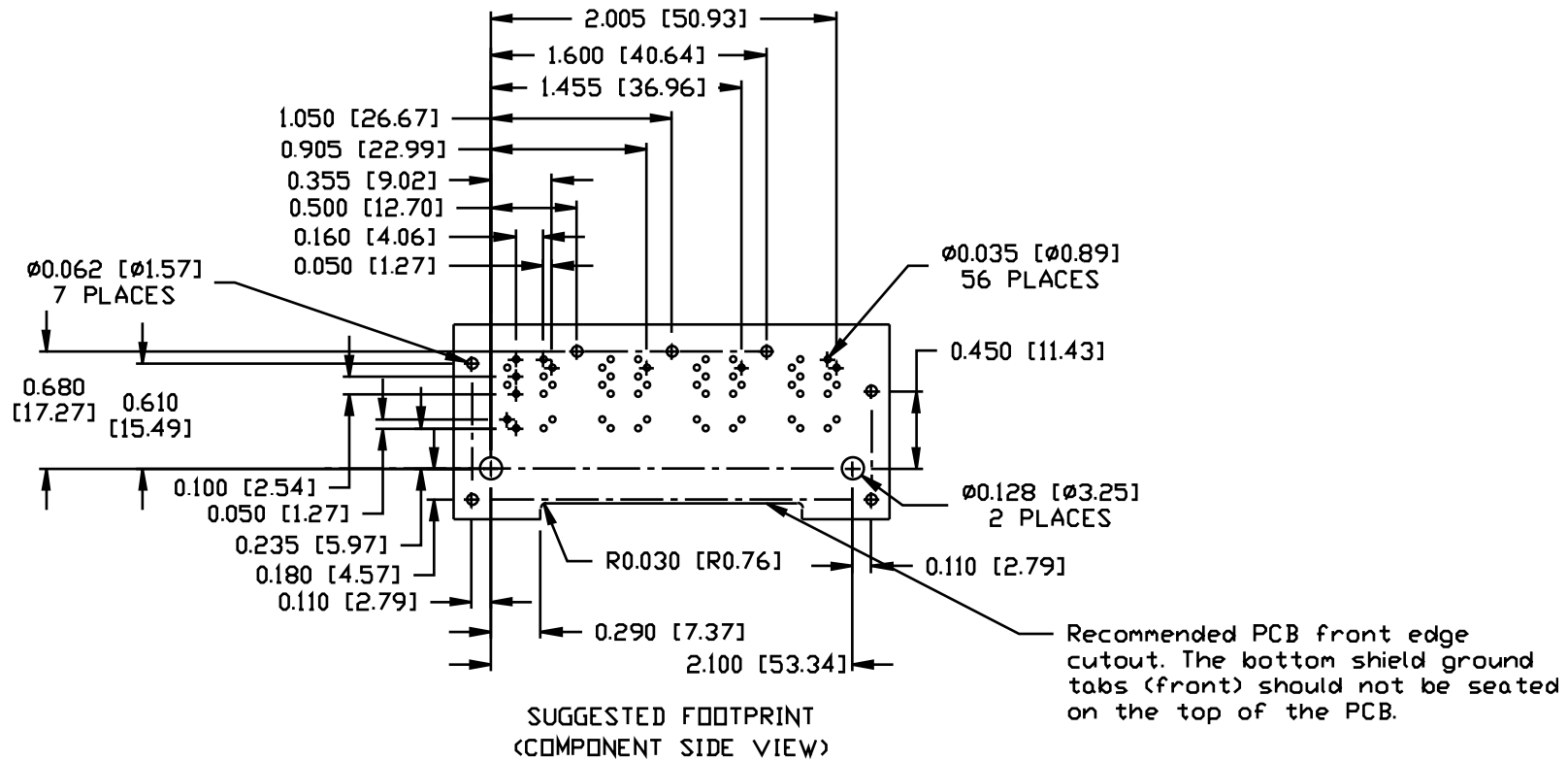

## INTEGRATED CONNECTOR MODULES

0833-2X4R-55-F Power over Ethernet MagJack® 2 x 4

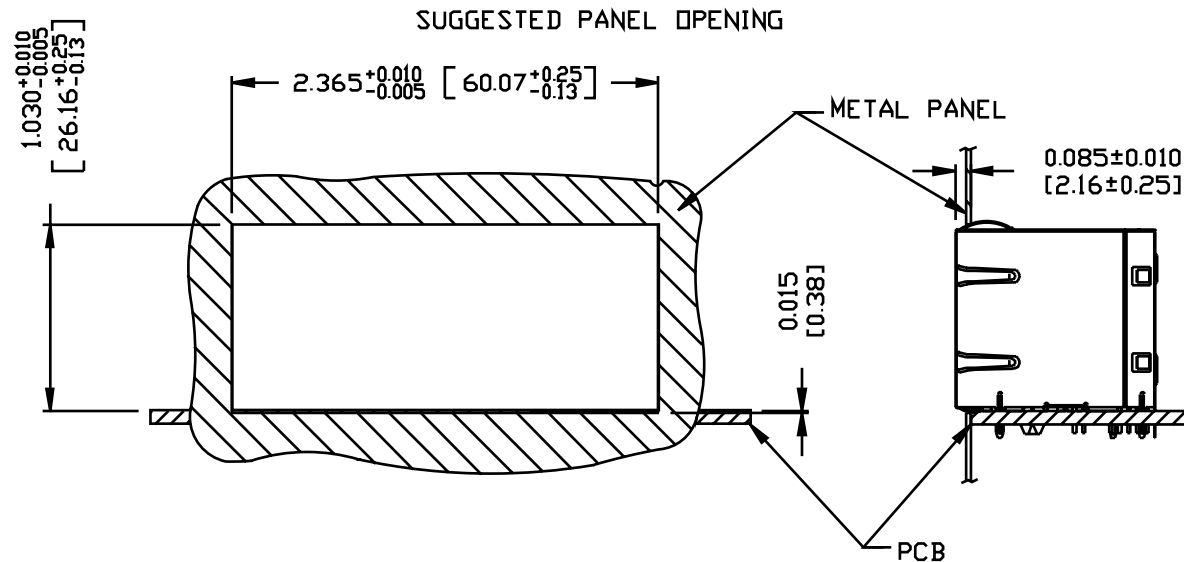

**NOTE:**

THE DISTANCE OF PANEL INSIDE SURFACE RELATIVE TO FRONT SURFACE OF PART IS ONLY A SUGGESTION. IN CASE THIS DISTANCE IS DIFFERENT, THE REQUIRED PANEL OPENING DIMENSIONS CHANGE ACCORDINGLY.

**PACKING INFORMATION**

PACKING TRAY : 0200-0148-46 (TOP)

0200-0148-47 (BOTTOM)

PACKING QUANTITY : 20 PCS FINISHED GOODS PER TRAY.

7 TRAYS (140 PCS FINISHED GOODS) PER CARTON BOX.

NOTE : CARDBOARDS ARE PLACED BETWEEN LAYERS OF PACKING TRAY INSIDE CARTON BOX.

(INCLUDE THE UPPERMOST AND LOWERMOST TRAY)