

REVISION HISTORY			
REV	DESCRIPTION	DATE	APPROVED
E	DCN 32902	03/05	BRT
D	DCN 37137	10/09	DAL

# PRODUCT DATA DRAWING

## MATERIAL

**BODY, INSERT:** STAINLESS STEEL PER AMS-5640, ALLOY UNS S30300, TYPE 303. COND. A

**CONTACT, E-RING, SPRING CLIP, CONTACT SLEEVE:** BERYLLIUM COPPER PER ASTM B196, COND. TD04, ALLOY UNS C17300

**SHIM SPRING, OUTER CONTACT:** BERYLLIUM COPPER PER ASTM B194, COND. TD04, ALLOY UNS C17200

**COIL SPRING:** MUSIC WIRE PER ASTM A228

**INSULATOR:** PTFE PER ASTM D1710, TYPE I, GRADE 1, CLASS B

## FINISH

**BODY, INSERT, CONTACTS, SPRING CLIP, SHIM SPRING:** GOLD PER ASTM B488, TYPE II, CODE C, CLASS .76; OVER NICKEL PER AMS-QQ-N-290, CLASS 1, .00010 MIN.

**E-RING:** NICKEL PER AMS-QQ-N-290, CLASS 1, GRADE G

**COIL SPRING:** ZINC PER ASTM B633

## PERFORMANCE

**IMPEDANCE:** 50 OHMS  
**FREQ. RANGE:** DC TO 18.0 GHz  
**D.W.V.:** 1000 VRMS  
**INSUL. RES.:** 5000 MEGOHMS MIN.

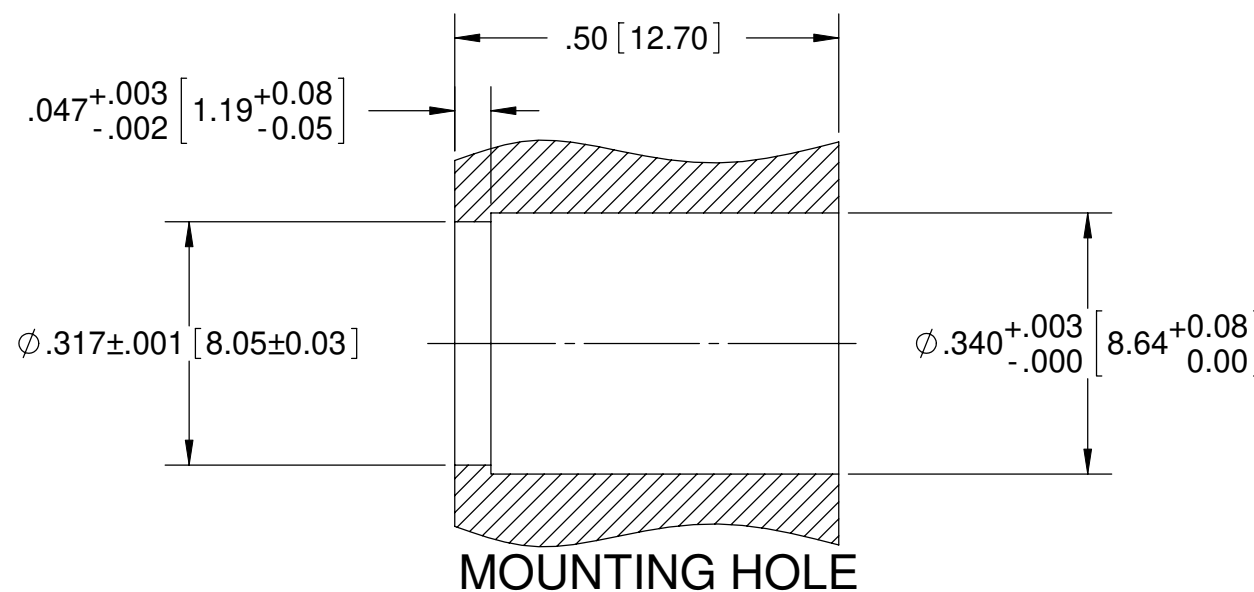
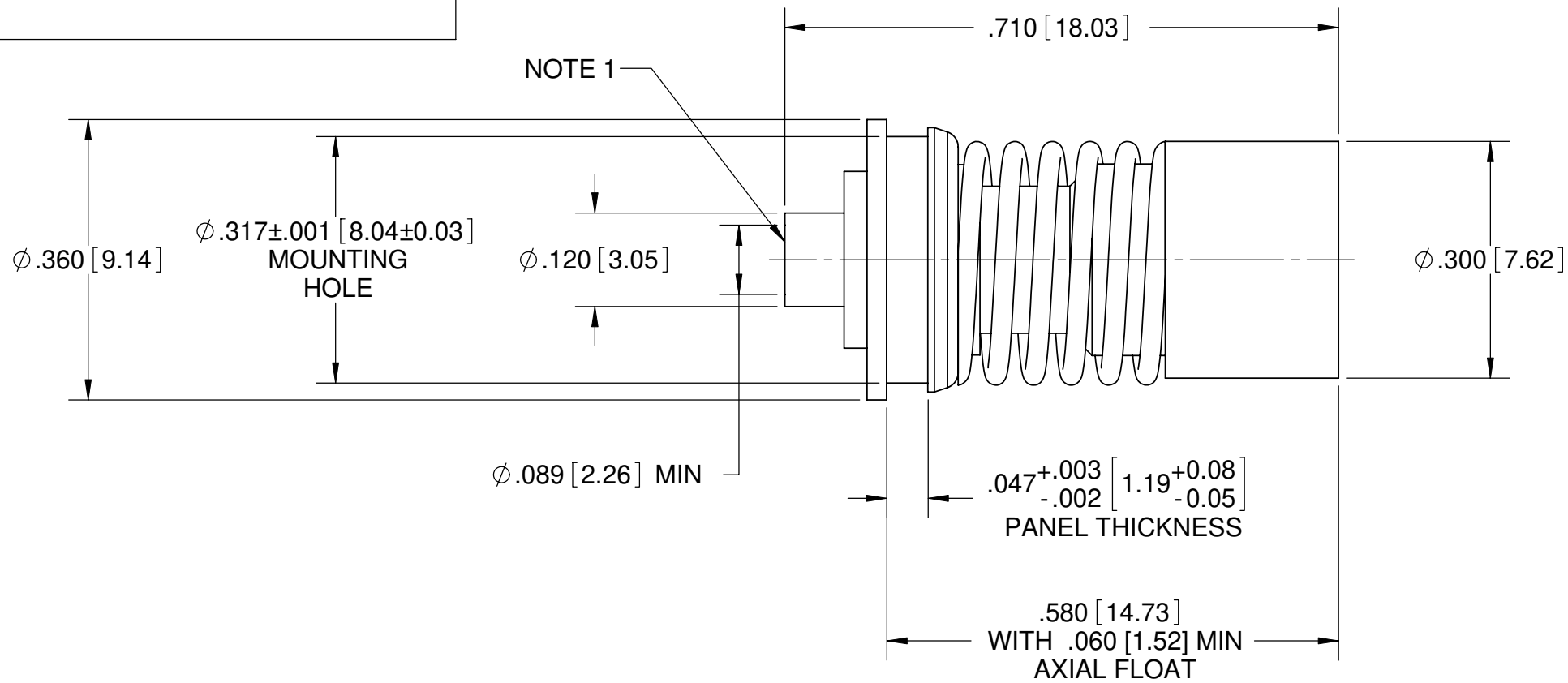

**NOTES:**  
 1. ACCEPTS .085 SEMI-RIGID CABLE OR T-FLEX 405 CABLE.

MATERIAL: SEE ABOVE	DIMENSIONS ARE IN INCHES TOLERANCES: FRACTIONAL: $\pm 1/64$ ANGULAR: X° $\pm 1'0''$ X°X' $\pm 15''$	UNLESS OTHERWISE SPECIFIED 1) ALL DIMENSIONS ARE IN INCHES[MILLIMETERS] 2) ALL DIMENSIONS ARE AFTER PLATING. 3) BREAK CORNERS & EDGES .005 R. MAX. 4) CHAM. 1ST & LAST THREADS. 5) SURFACE ROUGHNESS 63 S MIL-STD-10. 6) DIA.'S ON COMMON CENTERS TO BE CONCENTRIC WITHIN .005 T.I.R. 7) REMOVE ALL BURRS	<b>SV Microwave, Inc.</b> 2400 Centrepark West Drive, Suite 100 West Palm Beach, FL 33409	
FINISH: SEE ABOVE	DECIMAL: .X $\pm .030$ .XX $\pm .010$ .XXX $\pm .005$		TITLE: <b>BMA LOW PROFILE PANEL FEED THROUGH CABLE JACK FLOATING REAR MOUNT</b>	
SURFACE AREA: N/A	INTERPRET DIMENSIONS AND TOLERANCES PER ASME Y14.5M - 1994	THIRD ANGLE PROJECTION	DRAWN: VMJ 02/14/00	SIZE: <b>B</b> CAGE CODE: <b>95077</b> DWG. NO.: <b>1740-6001</b>
<b>PROPRIETARY</b> THE INFORMATION CONTAINED IN THIS DRAWING IS THE SOLE PROPERTY OF SV MICROWAVE, INC. ANY REPRODUCTION IN PART OR AS A WHOLE WITHOUT THE WRITTEN PERMISSION OF SV MICROWAVE, INC IS PROHIBITED.			CHECKED: STW 02/16/00	SCALE: 5:1
			APPROVED: STW 02/16/00	SHEET 1 OF 1