

# **BUF12800EVM Evaluation Board and Software Tutorial**

---



---



---

This user's guide describes the characteristics, operation, and use of the BUF12800EVM evaluation board. It discusses how to set up and configure the software and hardware and reviews various aspects of the program operation. Throughout this document, the terms *evaluation board*, *evaluation module*, and *EVM* are synonymous with the BUF12800EVM. This user's guide also includes information regarding operating procedures and input/output connections, an electrical schematic, printed circuit board (PCB) layout drawings, and a parts list for the EVM.

## **Contents**

1	Overview .....	2
2	BUF12800EVM Hardware Setup .....	3
3	BUF12800EVM Hardware .....	5
4	BUF12800EVM Features.....	11
5	BUF12800EVM Software Setup.....	13
6	BUF12800EVM Software Overview.....	16
7	BUF12800EVM Documentation .....	24

## **List of Figures**

1	BUF12800EVM Hardware Setup .....	3
2	BUF12800EVM Board Block Diagram .....	4
3	USB DIG Platform Block Diagram.....	5
4	Typical Hardware Connections for the BUF12800EVM .....	6
5	Connecting External Power to the BUF12800EVM .....	7
6	Connecting the USB Cable to the USB DIG Platform .....	8
7	Confirmation of USB DIG Platform Driver Installation .....	8
8	Default Jumper Locations for BUF12800EVM .....	9
9	BUF12800EVM Software Install Window .....	14
10	BUF12800EVM Software License Agreements .....	14
11	BUF12800EVM Software Installation Progress .....	15
12	BUF12800EVM Software About Button .....	15
13	BUF12800EVM Software Interface .....	16
14	Communication Error with USB DIG Platform.....	17
15	JMP6 Setting for Logic '0' .....	17
16	JMP6 Setting for Logic '1' .....	18
17	Measuring and Entering Power-Supply Voltage .....	18
18	Auto Write Feature Enabled .....	19
19	Save File Prompt .....	20
20	Saved Data Format .....	21
21	Load File Prompt .....	21
22	Run Batch Dialog.....	22
23	Control Panel Window.....	23

PowerPAD is a trademark of Texas Instruments.  
 Microsoft, Windows are registered trademarks of Microsoft Corporation.  
 WinZIP is a registered trademark of WinZip International LLC.  
 All other trademarks are the property of their respective owners.

24	BUF12800EVM Board Schematic.....	24
25	BUF12800EVM PCB Top Layer (Component Layout) .....	25

## 1 Overview

The [BUF12800](#) is a programmable gamma-voltage generator. This device offers 12 programmable gamma channels, making it ideal for 10-bit source TFT-LCD reference drivers.

The BUF12800EVM is a platform for evaluating the performance of the BUF12800 under various signal, reference, and supply conditions. This document gives a general overview of the BUF12800EVM, and provides a general description of the features and functions to be considered while using this evaluation module.

### 1.1 BUF12800EVM Kit Contents

[Table 1](#) lists the contents of the BUF12800EVM kit. Contact the [Texas Instruments Product Information Center](#) nearest you if any component is missing. It is highly recommended that you also check the [BUF12800 product folder](#) on the TI web site at [www.ti.com](http://www.ti.com) to verify that you have the latest versions of the related software.

**Table 1. BUF12800EVM Kit Contents**

Item	Quantity
BUF12800EVM PCB Test Board	1
USB_DIG_Platform PCB	1
USB Cable	1
Barrel plug cable assembly (part # 10-01935 - Tensility International Corporation) for external power supply	1
User's Guide CD-ROM	1

### 1.2 Related Documentation from Texas Instruments

The following documents provide information regarding Texas Instruments' integrated circuits used in the assembly of the BUF12800EVM. This user's guide is available from the TI web site under literature number **SBOU116**. Any letter appended to the literature number corresponds to the document revision that is current at the time of the writing of this document. Newer revisions may be available from the [TI web site](#), or call the Texas Instruments' Literature Response Center at (800) 477-8924 or the Product Information Center at (972) 644-5580. When ordering, identify the document by both title and literature number.

**Table 2. Related Documentation**

Document	Literature Number
BUF12800 Product Data Sheet	<a href="#">SBOS315</a>
USB_DIG_Platform User Guide	<a href="#">SBOU058</a>

## 2 BUF12800EVM Hardware Setup

This section discusses the overall system setup for the BUF12800EVM. The PC runs software that communicates with the USB\_DIG\_Platform. The USB DIG Platform generates the analog and digital signals used to communicate with the BUF12800 test board. Connectors on the BUF12800 test board allow the user to connect to the system under various test conditions and monitor the power, current, and voltage. A block diagram of the overall hardware setup is shown in [Figure 1](#).

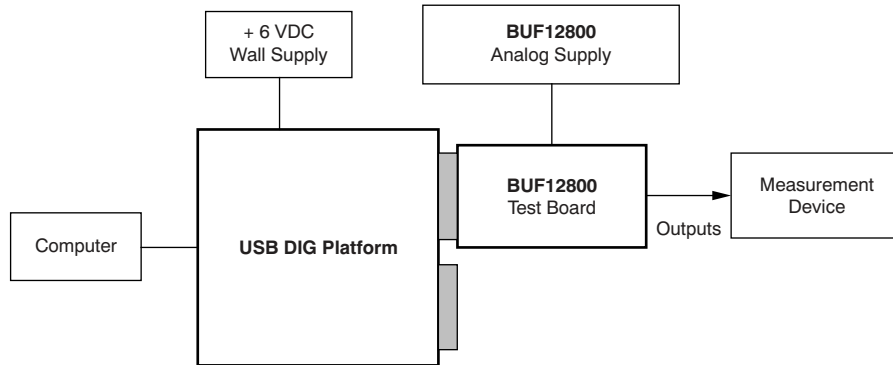

**Figure 1. BUF12800EVM Hardware Setup**

## 2.1 Theory of Operation for BUF12800 Hardware

Figure 2 shows the BUF12800 test board hardware setup. The functionality of the PCB is such that it provides connections to the I<sup>2</sup>C and general-purpose inputs/outputs (GPIOs) on the USB DIG Platform board. It also provides connection points for external connections of the shunt voltage, bus voltage, and ground.

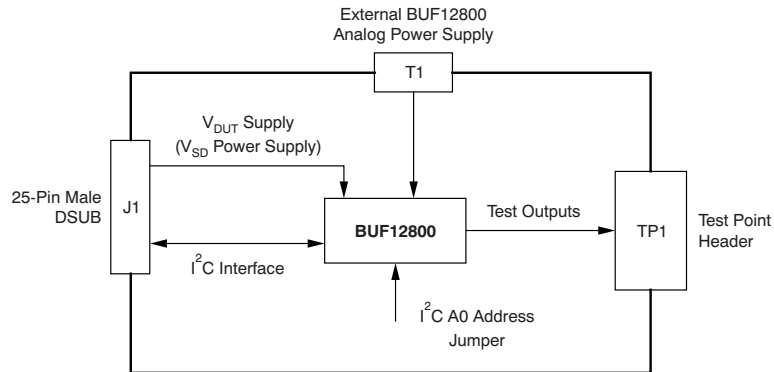

Figure 2. BUF12800EVM Board Block Diagram

## 2.2 Signal Definitions of J1 (25-Pin Male DSUB)

Table 3 shows the various signals connected to J1 on the BUF12800 test board.

Table 3. J1 Signal Definition for BUF12800EVM

Pin No on U1	Signal	BUF12800 Pin
1	N/C	No connection
2	N/C	No connection
3	N/C	No connection
4	N/C	No connection
5	N/C	No connection
6	N/C	No connection
7	N/C	No connection
8	N/C	No connection
9	I2C_SCK	No connection
10	I2C_SDA2	No connection
11	N/C	No connection
12	I2C_SCK_ISO	I <sup>2</sup> C clock signal (SCL) channel 1; can be disconnected using a switch
13	I2C_SDA_ISO	I <sup>2</sup> C data signal (SDA) channel 1; can be disconnected using a switch
14	N/C	No connection
15	N/C	No connection
16	N/C	No connection
17	V <sub>DUT</sub>	Switched 3-V/5-V power <sup>(1)</sup>
18	V <sub>CC</sub>	No connection
19	N/C	No connection
20	N/C	No connection
21	GND	Common ground connection
22	SPI_SCK	No connection
23	SPI_CS1	No connection
24	SPI_DOOUT1	No connection
25	SPI_DIN1	No connection

<sup>(1)</sup> When power is switched off, digital I/O is also switched off.

### 2.2.1 Theory of Operation for USB DIG Platform

Figure 3 shows the block diagram for the USB DIG platform. This platform is a general-purpose data acquisition system that is used on several different Texas Instruments evaluation modules. The details of its operation are included in a separate document, SBOU058 (available for download at [www.ti.com](http://www.ti.com)). The block diagram shown in Figure 3 gives a brief overview of the platform. The primary control device on the USB DIG platform is the TUSB3210.

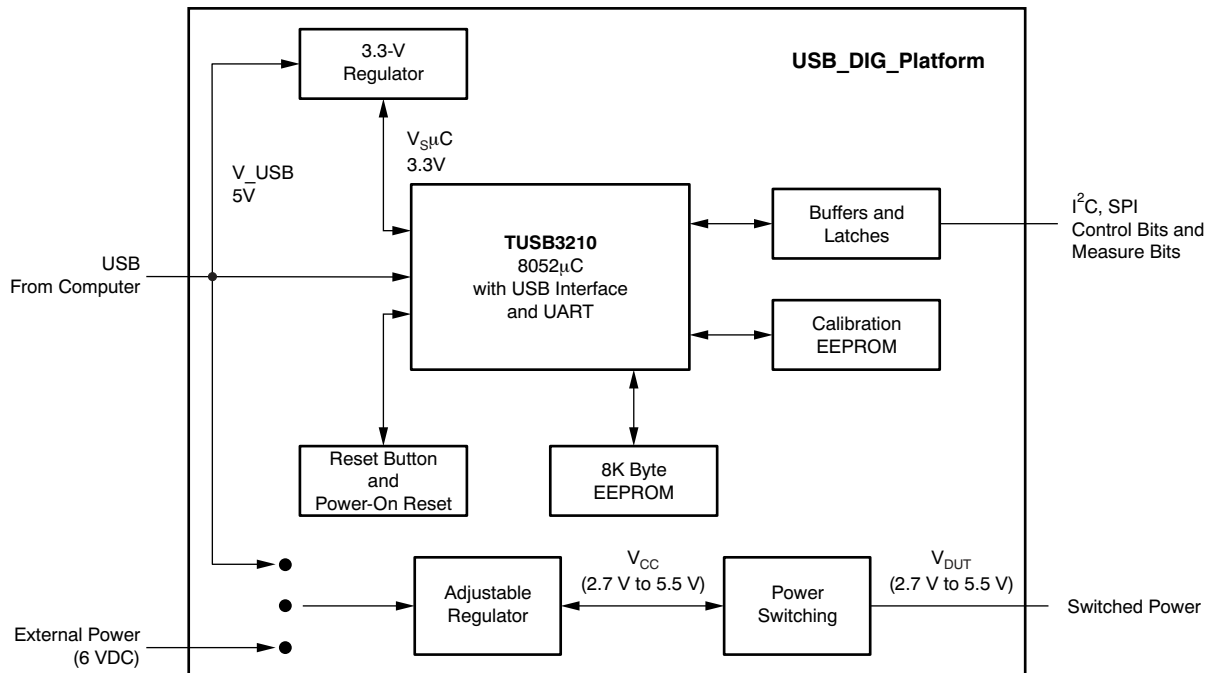

Figure 3. USB DIG Platform Block Diagram

## 3 BUF12800EVM Hardware

This section provides details about connecting the two PCBs of the BUF12800EVM together, applying power, connecting the USB cable, and setting the jumpers.

### 3.1 Electrostatic Discharge Warning

#### CAUTION

Many of the components on the BUF12800EVM are susceptible to damage by electrostatic discharge (ESD). Customers are advised to observe proper ESD handling precautions when unpacking and handling the EVM, including the use of a grounded wrist strap at an approved ESD workstation.

### 3.2 Typical Hardware Connections

Setting up the BUF12800EVM hardware involves connecting the BUF12800 test board and the USB DIG Platform together via a 25-pin DSUB connector and then applying power. The external connections may be connected to the real-world system that the BUF12800 is to be incorporated into. Figure 4 shows the typical hardware connections.

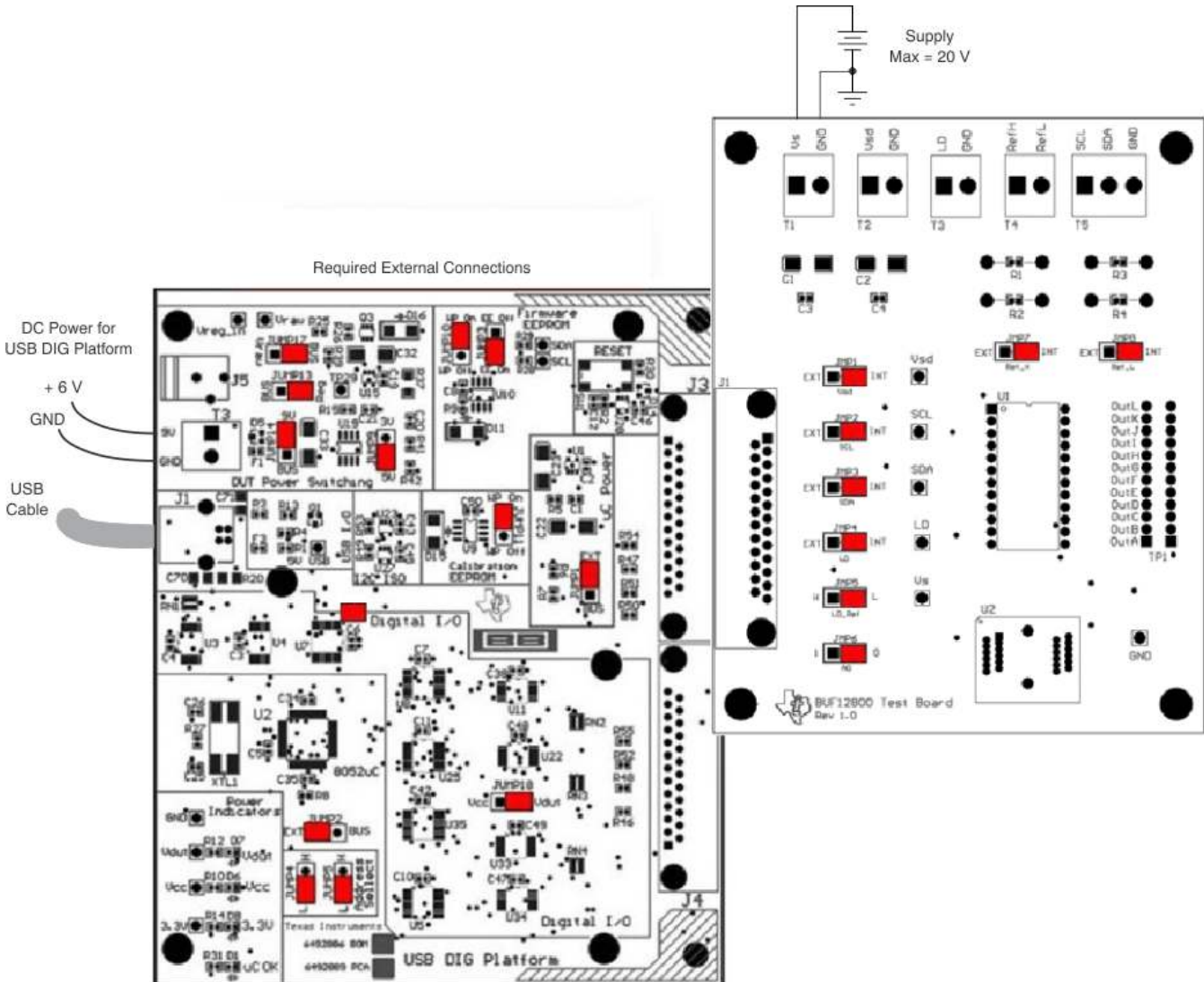

Figure 4. Typical Hardware Connections for the BUF12800EVM

### 3.3 Connecting the Hardware

To connect the BUF12800 Test Board and the USB DIG Platform together, gently push on both sides of the DSUB connectors. Note that the USB DIG Platform board has two DSUB connectors; either DSUB connector may be used. Make sure that the two connectors are completely pushed together; loose connections may cause intermittent operation.

### 3.4 Connecting Power

After the boards are conjoined, connect the +6-V wall supply to the USB DIG Platform board as shown in Figure 5. Note that it is always necessary to connect the power to the DIG before connecting the USB cable. If the USB cable is connected before the power, the computer may attempt communication to an unpowered device that is unable to respond. In addition, the BUF1280 test board requires an external dc power source. This source is not included with the kit, and its voltage may differ depending on your testing needs. The source will be used to provide dc supply voltage to the BUF1280 test board.

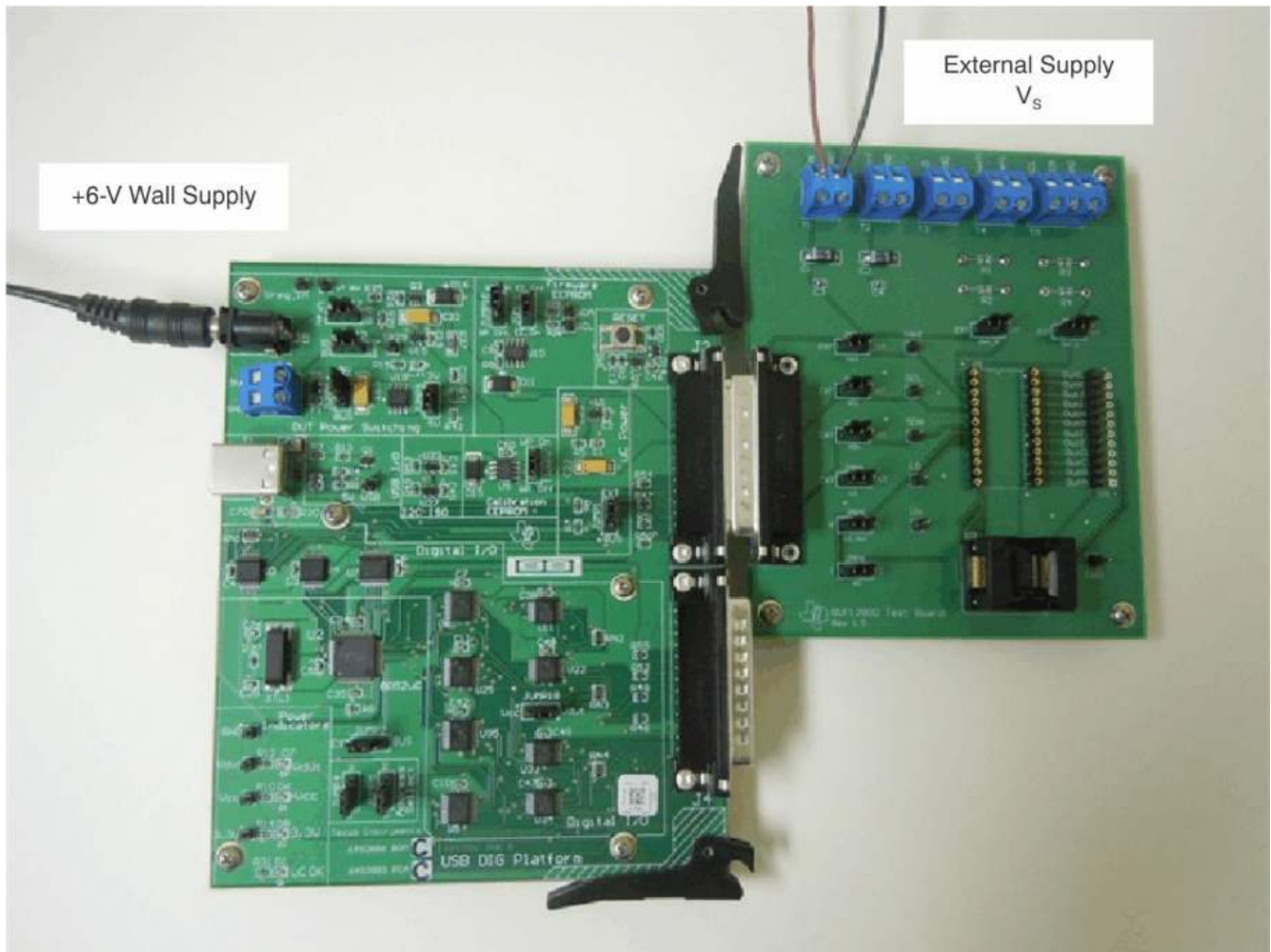
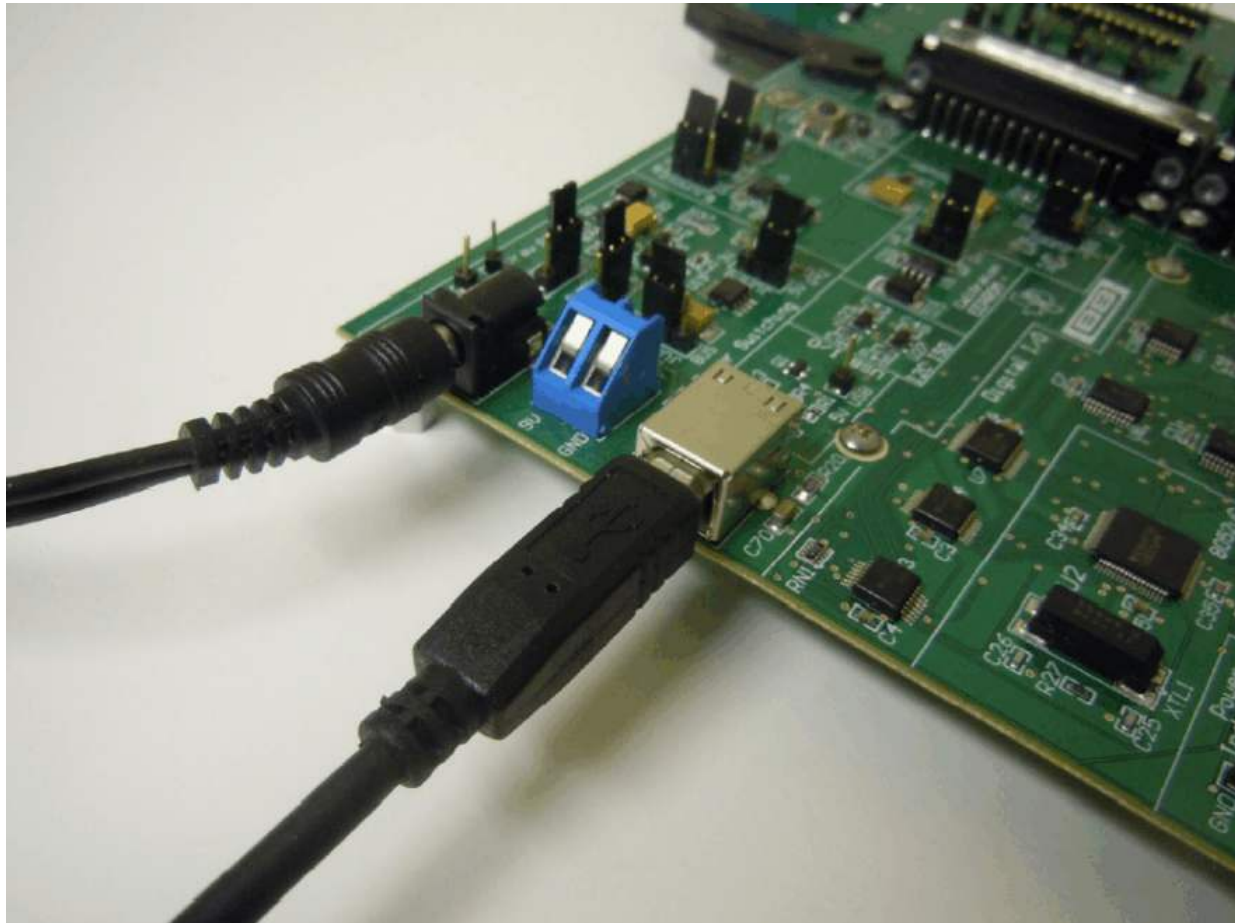

**Figure 5. Connecting External Power to the BUF1280EVM**



### 3.5 Connecting the USB Cable to the USB DIG Platform

Once power is connected, the USB cable must be connected to the DIG, as shown in [Figure 6](#).



**Figure 6. Connecting the USB Cable to the USB DIG Platform**

Note that the Test Board and USB DIG Platform must be powered on before connecting the USB cable. Typically, the computer responds with a *Found New Hardware, USB Device* pop-up dialog. The pop-up window typically changes to *Found New Hardware, USB Human Interface Device*. This pop-up window indicates that the device is ready to be used. The USB DIG Platform uses the human interface device drivers that are part of the Microsoft® Windows® operating system.

In some cases, the Windows *Add Hardware* wizard is shown. If this prompt appears, allow the system device manager to install the human interface drivers by clicking **Yes** when requested to install drivers. Windows then confirms installation of the drivers with the message shown in [Figure 7](#).



**Figure 7. Confirmation of USB DIG Platform Driver Installation**



### 3.6 BUF12800EVM Default Jumper Settings

Figure 8 shows the default jumpers configuration for the BUF12800EVM. In general, the jumper settings of the USB DIG Platform do not need to be changed. You may want to change some of the jumpers on the BUF12800 Test Board to match your specific configuration. For instance, you may wish to set a specific I<sup>2</sup>C address.

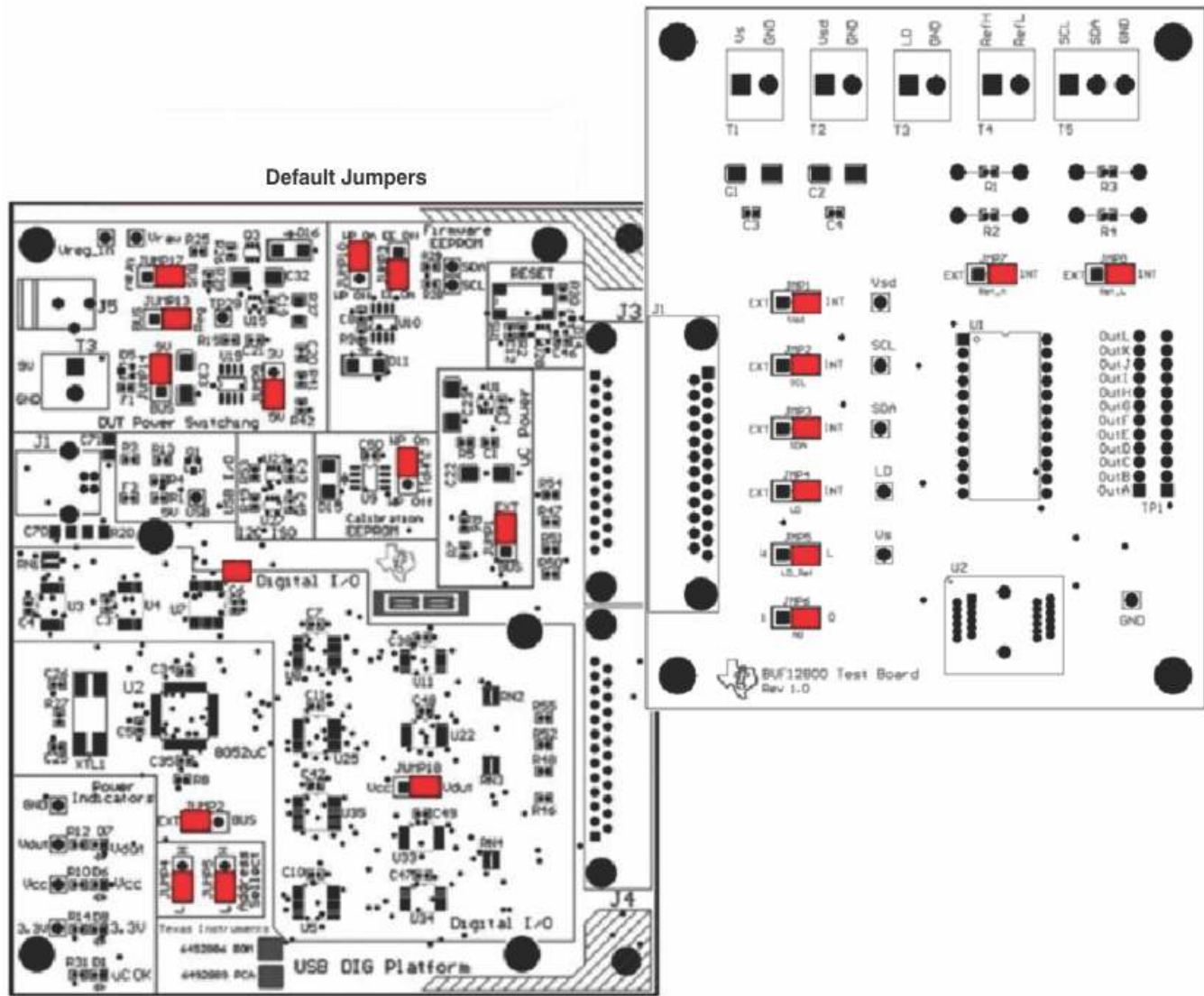

Figure 8. Default Jumper Locations for BUF12800EVM

Table 4 summarizes the function of the BUF12800 Test Board jumpers. For most application, jumpers 2 through 5 are all set to the default positions.

**Table 4. BUF12800 Test Board Jumper Functions**

Jumper	Default	Purpose/Description
JMP1	INT	This jumper selects whether the $V_{SD}$ pin on the BUF12800 is connected to the $V_{DUT}$ signal generated from the USB DIG Platform or whether digital supply pin is connected to terminal T2, allowing for an external supply to power the digital circuitry. The default INT position connects the $V_{SD}$ pin to the $V_{DUT}$ control signal.
JMP2	INT	This jumper selects whether the SCL pin on the BUF12800 is connected to the I2C_SCK_ISO signal generated from the USB DIG Platform or whether the SCL pin is connected to terminal T5, allowing for an external source to control the I <sup>2</sup> C clock line. The default INT position connects the SCL pin to the I2C_SCK_ISO control signal.
JMP3	INT	This jumper selects whether the SDA pin on the BUF12800 is connected to the I2C_SDA_ISO signal generated from the USB DIG Platform or whether the SDA pin is connected to terminal T5, allowing for an external source to control the I <sup>2</sup> C data line. The default INT position connects the SDA pin to the I2C_SDA_ISO control signal.
JMP4	INT	This jumper selects whether the LD pin on the BUF12800 is connected to jumper JMP5 or whether the LD pin is connected to terminal T3, allowing for an external source to control the latch pin. The default INT position connects the LD pin to jumper JMP5.
JMP5	L	This jumper selection depends on the configuration of JMP4. If JMP4 is set to INT, JMP5 is used to select whether or not the LD pin on the BUF12800 is connected to the $V_{SD}$ digital supply or whether the LD pin is connected to ground. The default LOW position connects the LD pin to ground. If JMP4 is set to the EXT position, JMP4 is not used.
JMP6	0	This jumper selects I <sup>2</sup> C A0 address selection. Two separate I <sup>2</sup> C addresses can be selected, depending upon whether JMP6 is set high or low.
JMP7	INT	This jumper selects whether or not the RefH pin on the BUF12800 is connected to the $V_s$ signal generated by the external analog power-supply input at terminal T1, or whether the RefH pin is connected to a user-designated reference, which is set using an external input at terminal T4 as well as resistors R1 and R2. The default INT position connects the RefH pin to the external power-supply input at terminal T1.
JMP8	INT	This jumper selects whether or not the RefL pin on the BUF12800 is connected to ground or whether the RefL pin is connected to a user-designated reference, which is set using an external input at terminal T4 as well as resistors R3 and R4. The default INT position connects the RefL pin to ground.

Table 5 summarizes the function of the USB DIG Platform jumpers. For most applications, the default positions should be used. A separate document ([SBOU058](#)) provides details regarding the operation and design of the USB DIG Platform.

**Table 5. USB DIG Platform Jumper Functions**

Jumper	Default	Purpose/Description
JUMP1	EXT	This jumper selects external power or bus power. External power is applied on J5 or T3 (up to +9 V DC). Bus power is +5 V from the USB. External power is typically used because the USB bus power introduces additional noise.
JUMP2	EXT	Same as JUMP1.
JUMP3	EE ON	This jumper determines where the TUSB3210 loads the USB DIG Platform firmware upon power-up or reset. The <i>EE Off</i> position is used for development or firmware update.
JUMP4, JUMP5	L, L	This jumper sets the address for the USB DIG Platform board. The only reason to change from the default is if multiple boards are being used.
JUMP9	5V	This jumper selects the voltage of the device under test supply ( $V_{DUT} = 5\text{ V}$ or $3\text{ V}$ ). This jumper is typically the only jumper that changes for most applications.
JUMP10	WP ON	This write protects the firmware EEPROM.
JUMP11	WP ON	This write protects the calibration EEPROM.
JUMP13	REG	Uses the regulator output to generate the $V_{DUT}$ supply. The USB bus can be used as the $V_{DUT}$ supply.
JUMP14	9V	Uses the external power (9 V as opposed to the bus)
JUMP17	BUS	While in the BUS position, $V_{DUT}$ operation is normal. While in the $V_{RAW}$ position, the $V_{DUT}$ supply is connected to an external source. This configuration allows for any value of $V_{DUT}$ between 3 V and 5 V. <sup>(1)</sup>
JUMP18	$V_{DUT}$	Connects the pull-up on GPIO to the $V_{DUT}$ supply or the $V_{CC}$ supply.

<sup>(1)</sup> Adjusting beyond this range damages the EVM.

## 4 BUF12800EVM Features

This section describes some of the hardware features present on the BUF12800 Test Board.

### 4.1 JMP1: $V_{SD}$ Control Setting

Jumper JMP1 selects where the BUF12800 digital supply pin is connected. If JMP1 is set to the INT position, the DVDD pin is connected to the switchable  $V_{DUT}$  signal generated from the USB DIG Platform. This voltage can be set to either +3.3 V or +5 V, depending on how JUMP9 on the USB DIG Platform is set. While JMP1 is set to the INT position, the  $V_{SD}$  Power button on the BUF12800 software is able to control whether the  $V_{DUT}$  supply voltage is turned on or off.

When JMP1 is set in the EXT position, an external supply connected to terminal T2 can be used to provide the digital supply voltage for the BUF12800.

#### 4.2 **JMP2: I<sup>2</sup>C SCL Control Setting**

Jumper JMP2 selects where the BUF12800 I<sup>2</sup>C SCL pin is connected. If JMP2 is set to the INT position, the I<sup>2</sup>C clock signal is generated from the I2C\_SCK\_ISO signal from the USB DIG Platform.

When JMP2 is set in the EXT position, an external source connected to SCL pin of terminal T5 can be used to provide the I<sup>2</sup>C SCK signal to the BUF12800.

#### 4.3 **JMP3: I<sup>2</sup>C SDA Control Setting**

Jumper JMP3 selects where the BUF12800 I<sup>2</sup>C SDA pin is connected. If JMP3 is set to the INT position, the I<sup>2</sup>C data signal is generated from the I2C\_SDA\_ISO signal from the USB DIG Platform.

When JMP3 is set in the EXT position, an external source connected to SDA pin of terminal T5 can be used to provide the I<sup>2</sup>C SDA signal for the BUF12800.

#### 4.4 **JMP4: LD Control Setting**

Jumper JMP4 selects the input that the LD latch pin of the BUF12800 is connected to. If JMP4 is set in the INT position, it is routed through the JMP5 jumper where the reference voltage can be set high or low (see [Section 4.5](#)).

When JMP4 is set to the EXT position, an external source connected to the LD pin of terminal T3 can be used to provide a reference voltage for the latch pin, which dictates the method by which the digital-to-analog converter (DAC) output voltage is updated.

#### 4.5 **JMP5: LD Reference Setting**

Jumper JMP5 is used to select the reference voltage that is connected to the LD latch pin. It is used only when jumper JMP4 is set to INT. If JMP5 is set to H, the latch pin is connected to the V<sub>SD</sub> supply voltage; this configuration allows all DAC output voltages to retain the respective values during data transfer until LD sees a low reference (such as when JMP5 is set to the L position).

When JMP5 is set to the L position, the LD latch pin is connected to ground. This setting updates each DAC output voltage whenever its corresponding register is updated.

#### 4.6 **JMP6: I<sup>2</sup>C Address Hardware Setting**

Jumper JMP6 sets the hardware configuration for the A0 I<sup>2</sup>C address pin on the BUF12800. Using JMP6, the A0 address can be set to either a logic '1' or a logic '0' to allow for two unique I<sup>2</sup>C addresses. See [Section 6.2.1](#) on how to configure the BUF12800EVM software to match the JMP6 hardware setting.

#### 4.7 **JMP7: RefH Control Setting**

Jumper JMP7 is selects where the BUF12800 high reference supply pin RefH is connected. If JMP7 is set to the INT position, RefH is connected to VS, the external analog supply input at terminal T1.

When JMP7 is set to the EXT position, the reference voltage is then designated by the user with the RefH pin of terminal T4, along with resistors R1 and R2. An external power supply is connected to the RefH pin of terminal T4, and R1 and R2 act as a voltage-divider circuit; the user sets the values of R1 and R2 to achieve the desired reference voltage using [Equation 1](#):

$$\text{RefH} = V_{\text{SUP\_H}} \left( \frac{R2}{R1 + R2} \right) \quad (1)$$

Where V<sub>SUP\_H</sub> is the input supply voltage seen at the RefH pin of terminal T4.

#### 4.8 **JMP8: RefL Control Setting**

Jumper JMP8 is selects where the BUF12800 high reference supply pin RefL is connected. If JMP8 is set to the INT position, RefL is connected to ground.

When JMP8 is set to the EXT position, the reference voltage is then designated by the user with the RefL pin of terminal T4, along with resistors R3 and R4. An external power supply is connected to the RefL pin of terminal T4, and R3 and R4 act as a voltage-divider circuit; the user sets the values of R3 and R4 to achieve the desired reference voltage using [Equation 2](#):

$$\text{RefL} = V_{\text{SUP\_L}} \left( \frac{R4}{R3 + R4} \right) \quad (2)$$

Where  $V_{\text{SUP\_L}}$  is the input supply voltage seen at the RefL pin of terminal T4.

#### 4.9 BUF12800 Device Placement

The BUF12800EVM provides two separate locations on the board where the BUF12800 test device can be installed.

Location U1 allows for a BUF12800 device that is soldered down on a DIP adaptor board to be installed on the BUF12800 Test Board. The output capability of the BUF12800 that is soldered on this adaptor board can be fully evaluated. The PowerPAD™ of this soldered BUF12800 is connected correctly and allows the device to dissipate the necessary power while being evaluated.

Location U2 on the BUF12800 Test Board is a 24-pin, QFN-package test socket that allows the user to evaluate and program many devices very quickly. One drawback to this socket is that there is no connection to the PowerPAD of the BUF12800. Because of this limitation, while the device is placed in this socket, it cannot be operated to its full output capability as a result of thermal dissipation limitations.

#### CAUTION

Only one location should be populated at a time. The use of both locations simultaneously will likely damage one or both of the devices under test.

#### 4.10 Terminal Strip TP1

Terminal strip TP1 provides the individual output signals on a single row of headers as well as a row of vias. This footprint offers the user multiple options to interface the output signals of the BUF12800 with an available display panel (provided by the user). The user can also develop a custom cable to connect the headers to this panel directly, or to solder the headers directly to the individual vias.

### 5 BUF12800EVM Software Setup

This section discusses how to install the BUF12800EVM software.

#### 5.1 BUF12800EVM Software Operating Systems

The BUF12800EVM software has been tested on Microsoft Windows XP, Vista, and Windows7 operating systems (OS) with United States and European regional settings. The software should also function on other Windows OS platforms.

#### 5.2 BUF12800 Software Installation

The BUF12800EVM software is included on the CD that is shipped with the EVM kit. It is also available through the BUF12800EVM product folder on the [TI web site](#). To download the software to your system, insert the disc into an available CD-ROM drive. Navigate to the drive contents and open the BUF12800EVM software folder. Locate the compressed file (*BUF12800EVM.zip*) and open it. Using WinZIP® or a similar file compression program; extract the BUF12800EVM files into a specific BUF12800EVM folder (for example, *C:\BUF12800EVM*) on your hard drive.

Once the files are extracted, navigate to the BUF12800EVM folder you created on your hard drive. Locate the *setup.exe* file and execute it to start the installation. The BUF12800 software installer file then opens to begin the installation process, as shown in [Figure 9](#).



**Figure 9. BUF12800EVM Software Install Window**

After the installation process initializes, the user is given the choice of selecting the directory to install the program. Generally, defaulting to *C:\Program Files\BUF12800\* and *C:\Program Files\National Instruments\* is an acceptable choice. Following this option, two license agreements are presented that must be accepted as shown in [Figure 10](#).



**Figure 10. BUF12800EVM Software License Agreements**



After accepting the Texas Instruments and National Instruments license agreements, the progress bar opens and shows the installation of the software, as [Figure 11](#) illustrates. Once the installation process is completed, click **Finish**.

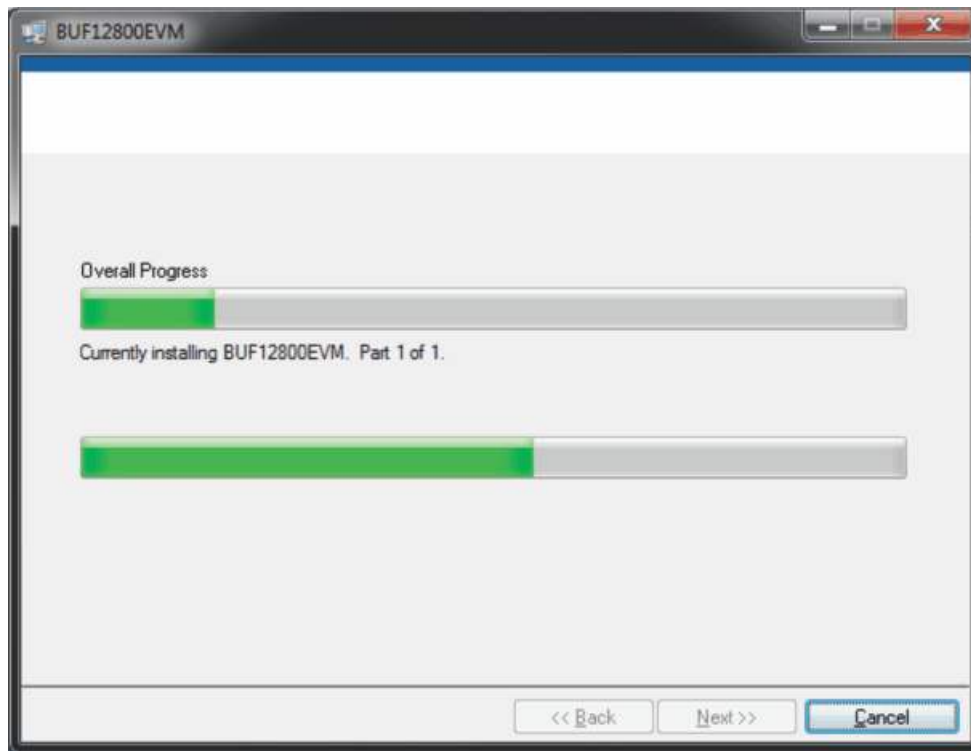

**Figure 11. BUF12800EVM Software Installation Progress**

### 5.3 Software Description and Set-Up

The BUF12800EVM software allows the user to read and write to all registers in the BUF12800 gamma correction buffer. Furthermore, it allows programming of the OTP register on the BUF12800. The software also permits the user to select either I<sup>2</sup>C address. Press the **About** button to verify that you have the latest version of the software; the contents of this window are shown in [Figure 12](#).



**Figure 12. BUF12800EVM Software About Button**

## 6 BUF12800EVM Software Overview

This section discusses how to use the BUF12800EVM software.

### 6.1 Starting the BUF12800EVM Software

The BUF12800EVM software can be operated through the *Start* menu in Windows. From the Start menu, select *All Programs*, and then select the *BUF12800EVM* program to start the software. [Figure 13](#) shows how the software should appear if the BUF12800EVM is functioning properly.

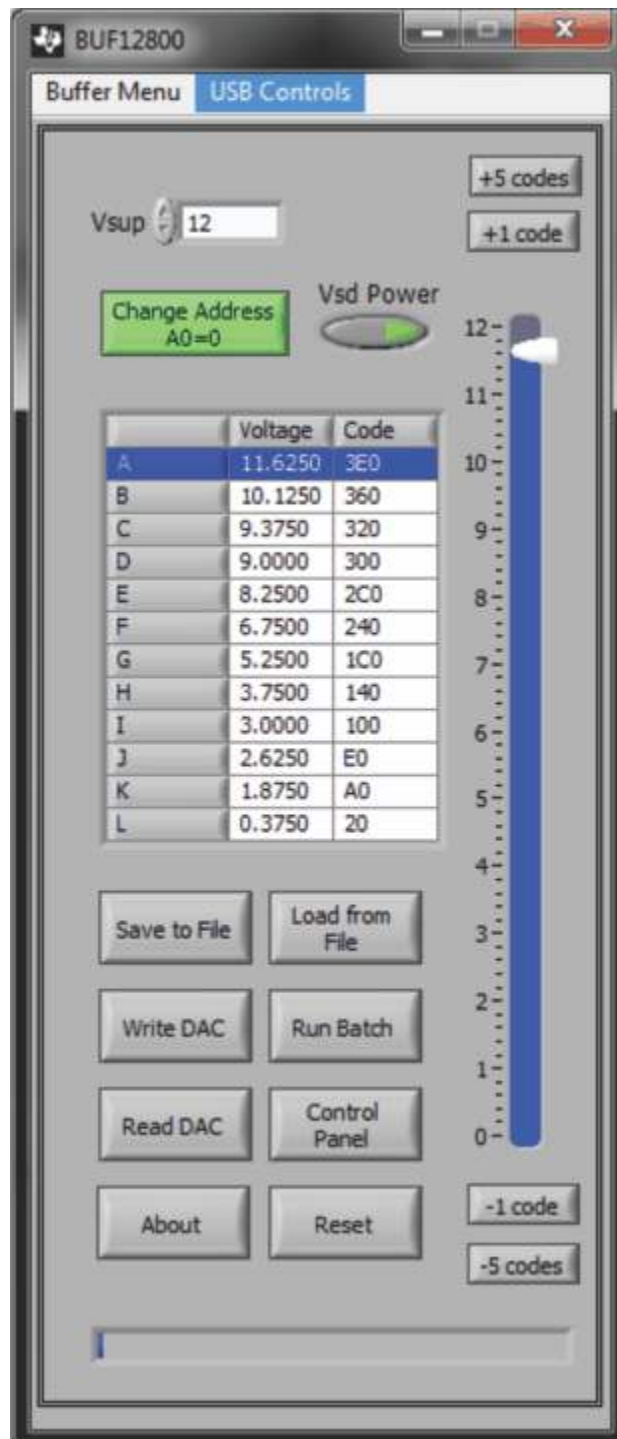

**Figure 13. BUF12800EVM Software Interface**

Figure 14 shows an error that pops up if the computer cannot communicate with the EVM. If you receive this error, first ensure that the USB cable is properly connected on both ends. This error can also occur if you connect the USB cable before the USB DIG Platform power source. Another possible cause for this error is a problem with the USB Human Interface Device Driver on the computer you are using. Make sure that the device is recognized when the USB cable is plugged in; this action is indicated by a Windows-generated confirmation sound.



Figure 14. Communication Error with USB DIG Platform

## 6.2 Using the BUF12800 Software

### 6.2.1 I<sup>2</sup>C Address Selection

As mentioned previously (refer to Section 4.6), jumper JMP6 is used to set the I<sup>2</sup>C address pin of the BUF12800. Figure 15 shows how the hardware and software must both be set to enable communication between the BUF12800EVM and the software. Without jumper JMP6 and the software address button configured correctly, the software cannot communicate with the BUF12800 device.

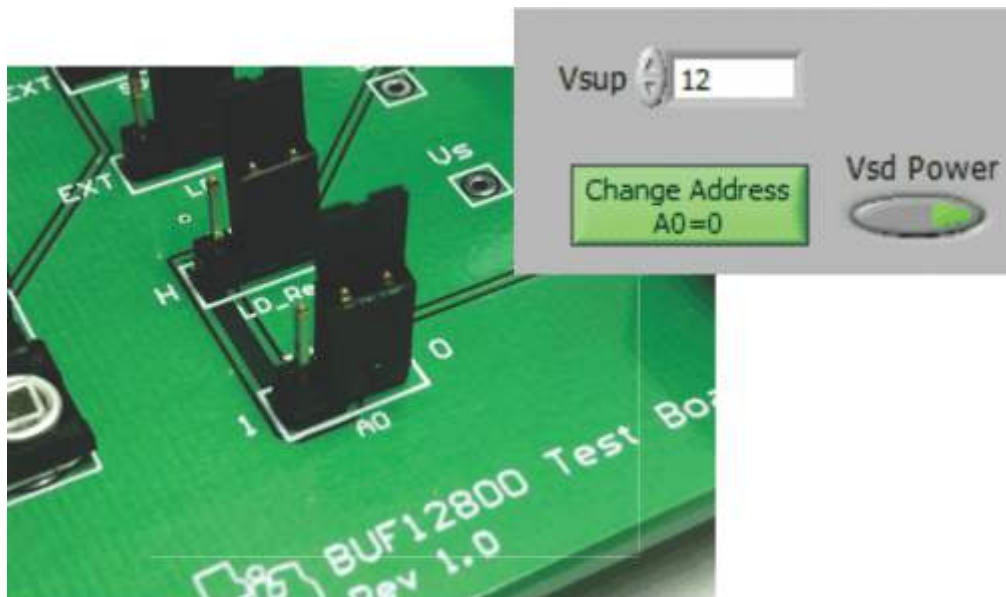
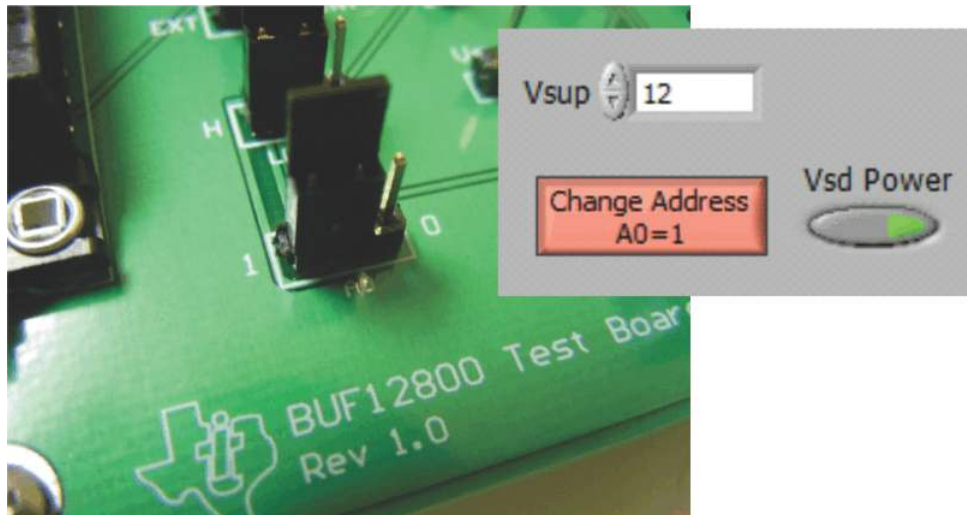

Figure 15. JMP6 Setting for Logic '0'

When JMP6 and the software are set as shown in [Figure 16](#), the second I<sup>2</sup>C address can be configured.



**Figure 16. JMP6 Setting for Logic '1'**

### 6.2.2 Measuring the Power Supply

You must measure the power supply ( $V_S$ ) with respect to the GND on the BUF12800 Test Board and enter it in the  $V_{sup}$  field located in the top section of the software interface as shown in [Figure 17](#).

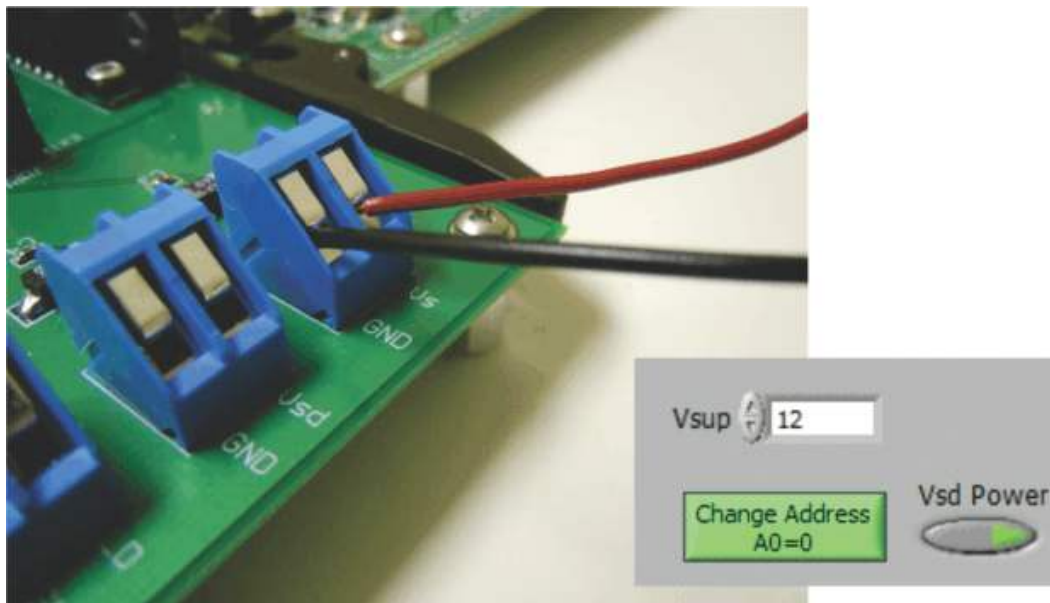

**Figure 17. Measuring and Entering Power-Supply Voltage**

The voltage out of each DAC is calculated according to the  $V_S$  value entered.

Changing the value in the channel 6 cell as shown below, for instance, immediately changes the output of channel 6 to 0.996 V. The calculation is performed according to [Equation 3](#).

$$V_{\text{DAC\_CHANNEL}} = \frac{V_S \times \text{Code\_in\_decimal}}{1024} \quad (3)$$

For example:

Channel 6: Code 44 (hexadecimal) = 68 (decimal)

$$V_{\text{DAC\_CHANNEL}} = \frac{15 \text{ V} \times 68}{1024} = 0.996 \text{ V} \quad (4)$$

### 6.2.3 Read DAC Button

By pressing the **Read DAC** button in the BUF12800EVM software, all of the BUF12800 DAC registers are read to obtain the respective current register contents. Once the read procedure is complete, all of the corresponding text boxes are updated to show the current values present in the DAC registers.

### 6.2.4 Write DAC Button

The method used to write the values in the DAC registers is based on whether or not the Auto Write feature is enabled. The BUF12800 has two methods of writing information into the DAC registers. The first method allows for the output voltage to change immediately after the writing to the DAC register. In the BUF12800EVM software, this mode is configured by enabling the Auto Write feature found in the *Buffer Menu* drop-down menu. In this mode, as an individual channel is written to, the output voltage changes as soon as the user moves to a different text box in the software.

The second method of writing to the DAC registers allows for the user to write multiple channels and then have all of the output voltages change at the same time, rather than each channel voltage changing as soon as it is written to. Disabling the Auto Write feature in the software allows the user to enter all of the desired values for all of the channels, and then press the **Write DAC** button to change all of the output voltage of all of the channels at one time. When the Auto Write feature is enabled, no change occurs to the output voltages when the **Write DAC** button is pressed. This action occurs because after the text box for a given channel has been updated, as soon as another item in the software is clicked, the Auto Write feature automatically performs a write command to the updated channel that then updates the output voltage. When in the Auto Write enabled mode, the Write DAC button cannot be pressed with data in the corresponding channel text boxes that are different than the values already stored in the DAC register; no change to the DAC registers will occur. [Figure 18](#) shows the location in the Buffer Menu with the Auto Write feature enabled. Click the Auto Write feature again to enable/disable the feature, depending upon its current state.

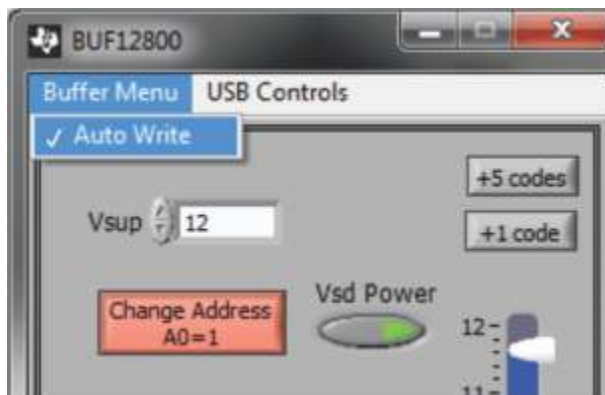

**Figure 18. Auto Write Feature Enabled**

### 6.2.5 Reset Button

Pressing the **Reset** button in the BUF12800EVM software performs two functions. First, a General-Call Reset for the BUF12800 is performed. The status of the DAC registers after this General-Call Reset default to *1000000000*, or mid-supply. The second function performed after the **Reset** button is pressed is that a Read DAC call is made to update the corresponding channel text boxes to the current value for each channel.

## 6.2.6 Save to File Button

The register configurations of the BUF12800 DACs are displayed in both analog voltage and in hexadecimal (refer to [Figure 13](#)). The DAC codes (that is, gamma voltages) can also be saved to a text file (.txt) using the **Save to File** button.

Pressing the **Save to File** button opens a file-save dialog box similar to that shown in [Figure 19](#). Pressing the folder icon creates a new folder on your PC. It is a good idea to create a directory exclusively for BUF12800 DAC code (gamma voltage) files. Enter a unique file name in the *File name* field to store your BUF12800 register information. Press the **OK** button to save the file.

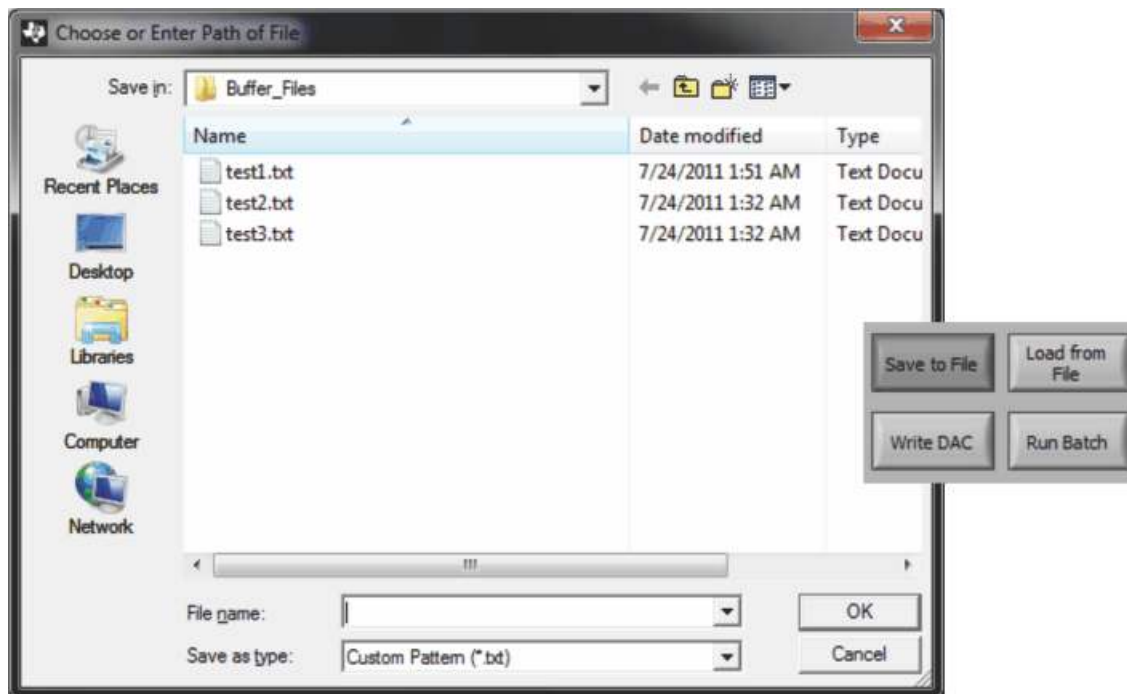

**Figure 19. Save File Prompt**



Saving the BUF12800 DAC codes (gamma voltages) creates a text file that can be opened in a text editor, as illustrated in [Figure 20](#).

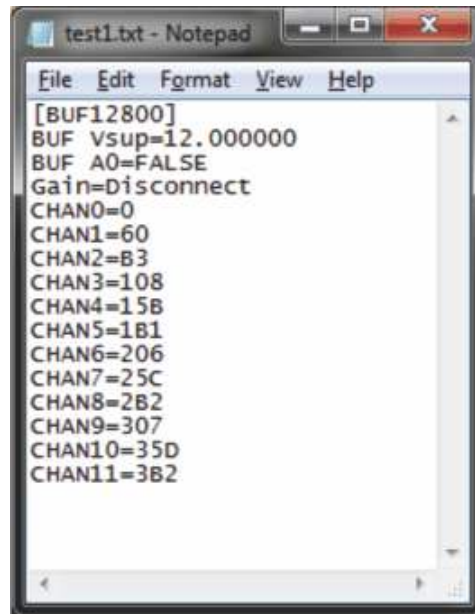

Figure 20. Saved Data Format

### 6.2.7 Load From File Button

The BUF12800EVM software is also able to load data saved from previous evaluations. A saved register configuration can be loaded into the BUF12800 using the **Load From File** button, shown in [Figure 21](#). The program recalls where you saved the last register configuration. Simply select the desired configuration and press **Open**.

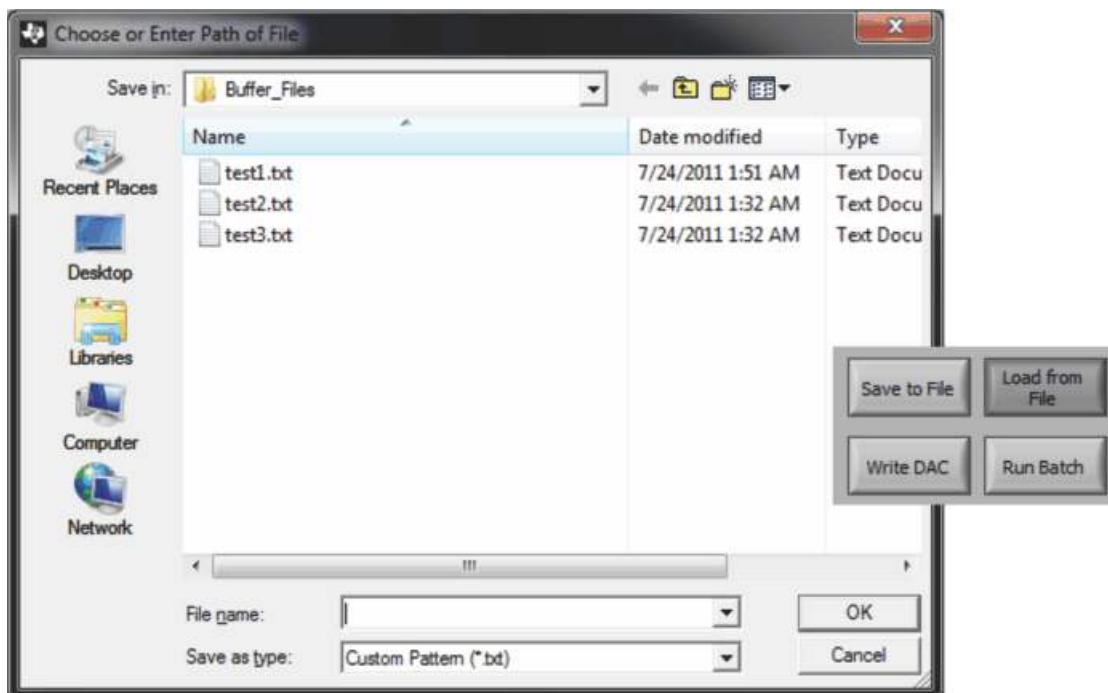

Figure 21. Load File Prompt

### 6.2.8 Changing DAC Analog Voltage

The voltage of any of the DAC channels can be adjusted in several ways. One way is to change the voltage by entering the desired voltage directly in the voltage text box. In order to be able to manually type the voltage into the text box, first click on the cell to be edited. Click a second time and the cell turns from blue to black and allows the updated voltage to be typed in the cell. The hexadecimal DAC codes can be entered in the *Code* column in the same manner.

Another method of changing the voltage of a DAC channel is through the use of the slider on the main software window (refer to Figure 13). There is only a single slider that is used for all channels. In order to use the slider to adjust the voltage of a particular channel, the channel must first be selected. Clicking on either the channel number, voltage, or code of a particular channel highlights the entire channel row and makes it blue to indicate which channel is selected. Adjusting the slider bar then only updates the highlighted channel.

The final method to change the DAC voltages is through the **±1 Code** and **±5 Code** buttons on the main software window. These buttons allow for fine and coarse adjustments to the highlighted channel to allow the user to quickly step the channel output up or down as needed, without having to manually enter the changes in the Code column.

### 6.2.9 Run Batch Button

The **Run Batch** button (as indicated in Figure 22) enables the user to configure the BUF12800 to cycle through different register configurations in a continuous loop. When connected to the end application, this feature can be used to cycle through different gamma settings to determine what the optimal settings must be for a given application.

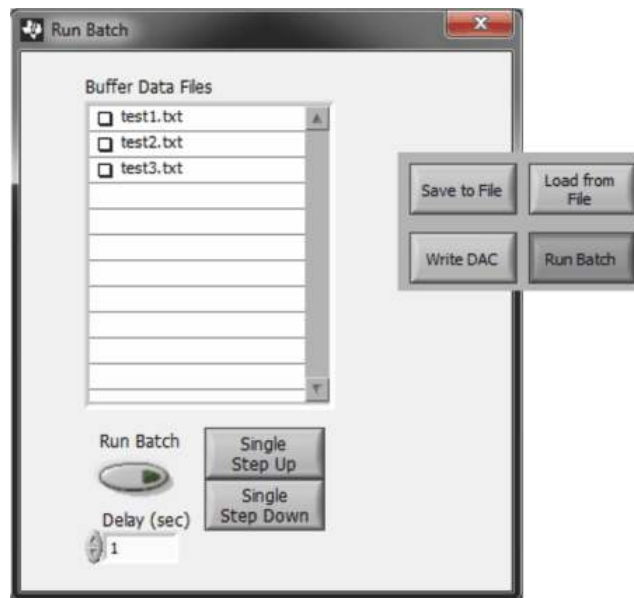

Figure 22. Run Batch Dialog

When the **Run Batch** button is pressed, a new dialog box displays as Figure 22 shows. The delay time is the amount of time between loading new configurations into the BUF12800.

Use the **Single Step Up** and **Single Step Down** buttons to step through the selected files manually. The currently-selected file name is displayed in the lower left corner area of the dialog box. Double-click on the file names to select them. Once the names have been selected, the check box turns dark. Double-click on the file name again to unselect it from the batch run. In Figure 22, two configuration files are selected.

### 6.2.10 Control Panel Button

Pressing the **Control Panel** button brings up a display panel that allows you to adjust each channel using a set of graphical sliders, as shown in [Figure 23](#). Simply drag the slider to adjust the desired channel output. The DAC code and corresponding output value of each channel changes automatically. This action is similar to the slider present on the main BUF12800EVM software window that changes based on the channel that is highlighted.

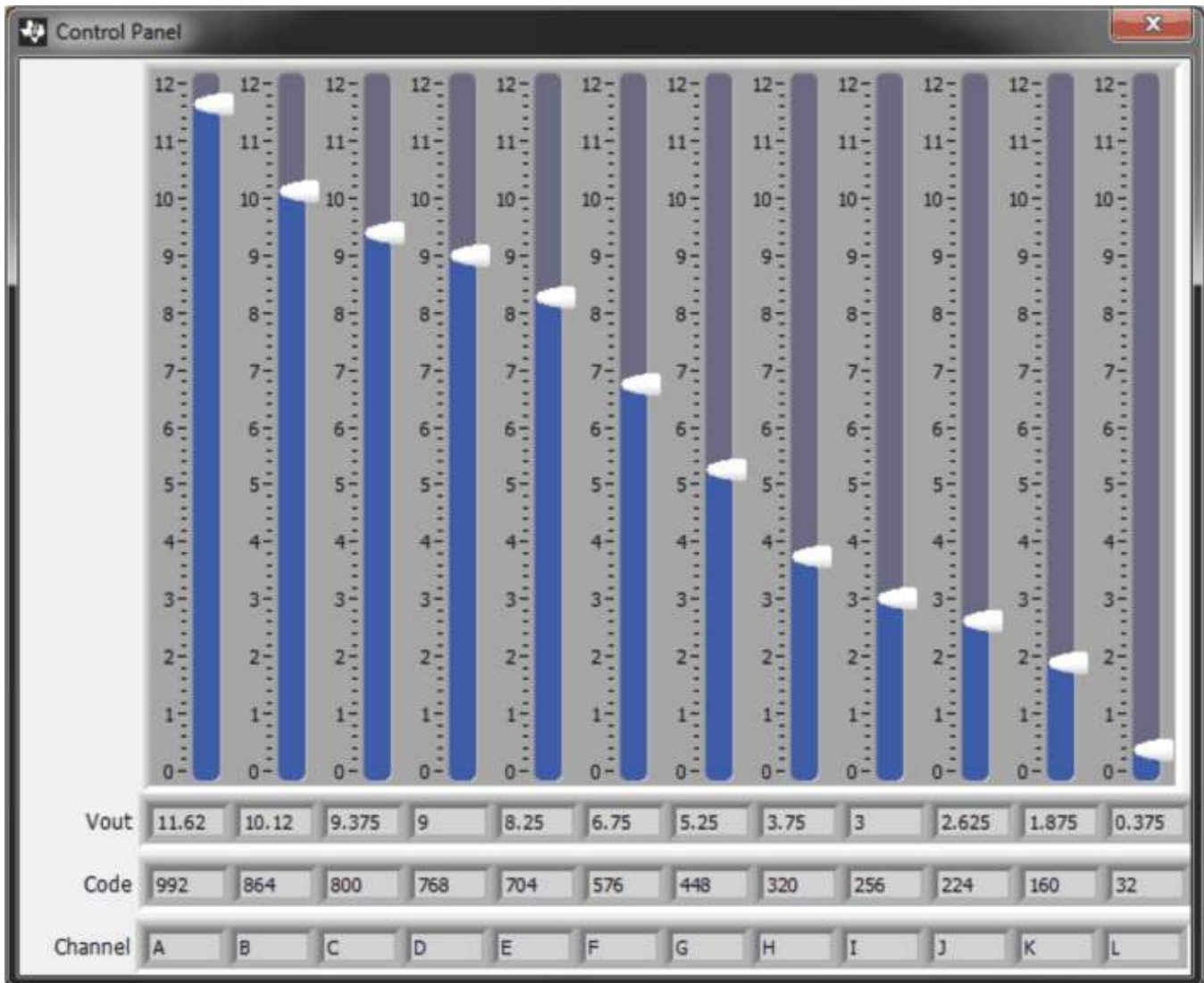

Figure 23. Control Panel Window

## 7 BUF12800EVM Documentation

This section contains the complete bill of materials and PCB layout for the BUF12800EVM.

**NOTE:** These board layouts are not to scale. These image are intended to show how the board is laid out; they are not intended to be used for manufacturing BUF12800EVM PCBs.

### 7.1 BUF12800EVM Board Schematic

Figure 24 shows the schematic for the BUF12800EVM board.

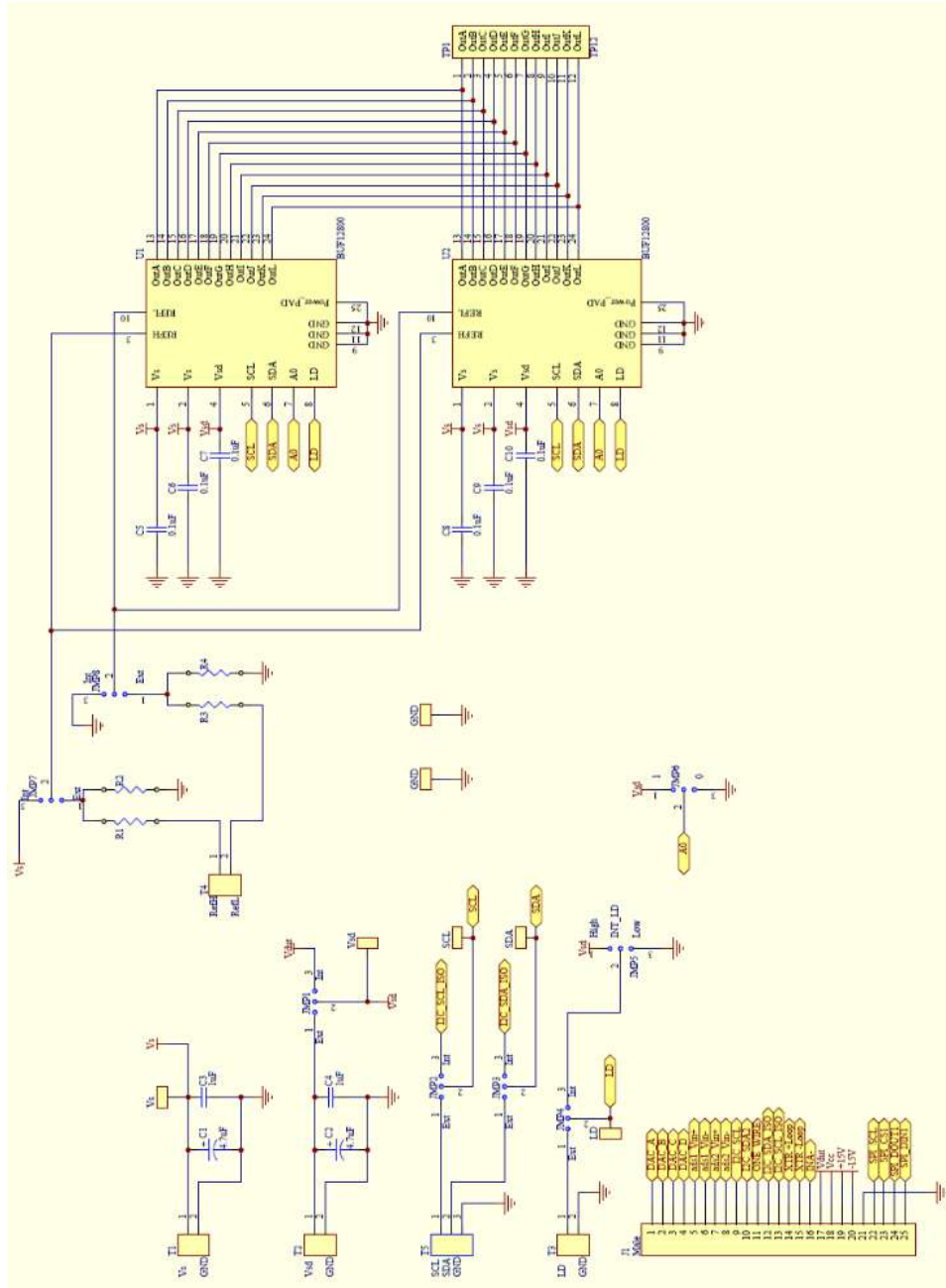

Figure 24. BUF12800EVM Board Schematic

## 7.2 PCB Layout

Figure 25 shows the PCB layout of the BUF12800EVM.

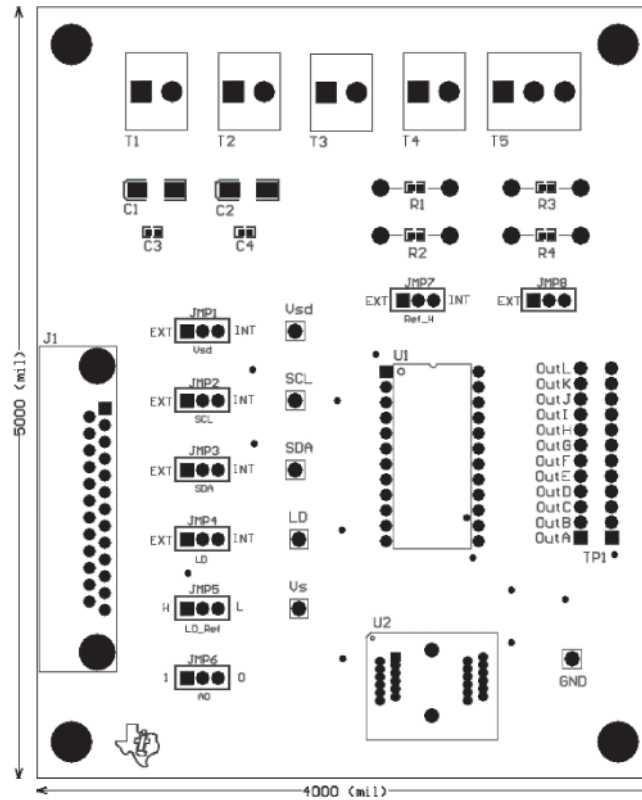

Figure 25. BUF12800EVM PCB Top Layer (Component Layout)

### 7.3 Bill of Materials

Table 6 lists the bill of materials for the BUF12800EVM.

**Table 6. BUF12800EVM Test Board Bill of Materials**

Item No.	Qty	Value	Ref Des	Description	Vendor/Mfr	Part Number
1	4	Various	R1 to R4	Resistor, 1/16W 5% 0603 SMD	Susumu Co Ltd	Various
2	2	4.7 $\mu$ F	C1, C2	Capacitor, tantalum, 4.7 $\mu$ F 35 V 10% SMD	Vishay/Sprague	293D475X9035C2TE3
3	2	1 $\mu$ F	C3, C4	Capacitor, ceramic, 1 $\mu$ F 25 V X7R 0402	Murata Electronics North America	GRM188F51E105ZA12D
4	6	0.1 $\mu$ F	C5 to C10	Capacitor ceramic, 0.1 $\mu$ F 25 V Y5V 0603	Kemet	C0603C104Z3VACTU
5	1	—	U1	Connector, Rcpt .100 in, 12-Pos Gold T/H	Samtec	SS-112-G-2
6	2	—	U2	Socket, TSSOP 24-Pin ZIF	ENPLAS	OTS-24(28)-0.65-02-00
7	1	DSUB 25M	J1	Connector, D-SUB Plug R/A 25-Pos 30 Gold (with threaded inserts and board locks)	AMP/Tyco Electronics	5747842-4
8	4	—	T1 to T4	Terminal block 5 MM 2 Pos	On-Shore Technology Inc	ED300/2
9	1	—	T5	Terminal block 5 MM 3 Pos	On-Shore Technology Inc	ED300/3
10	1	—	TP1	Connector, Header 12-Pos .100 in., SGL Gold	Samtec	TSW-112-07-G-S
11	6	—	All Test Points (V <sub>S</sub> , V <sub>SD</sub> , SCL, SDA, LD, GND)	Connector, Header 1-Pos .100 in., SGL Gold	Samtec	TSW-101-07-G-S
12	4	Standoff	None	Standoffs, Hex , 4-40 Threaded, 0.500 in., length, 0.250 in. OD, Aluminum Iridite Finish	Keystone	2203
13	4	Screw	None	Screw Machine Phillips, 4-40X1/4 SS	B & F Fastener Supply	PMSSS 440 0025 PH
14	8	Strip cut to size (length is 3 pos.)	JMP1 to JMP8	Connector, Header 3-Pos .100 in., SGL Gold	Samtec	TSW-103-07-G-S
15	8	Jumper	JMP1 to JMP8	Shunt LP w/Handle 2-Pos 30AU	AMP/Tyco Electronics	881545-2

### Revision History

NOTE: Page numbers for previous revisions may differ from page numbers in the current version.

#### Changes from Original (September 2011) to A Revision

Page

- Changed power supply in the *BUF12800EVM Kit Contents* section. .... 2



## STANDARD TERMS AND CONDITIONS FOR EVALUATION MODULES

1. *Delivery:* TI delivers TI evaluation boards, kits, or modules, including any accompanying demonstration software, components, or documentation (collectively, an "EVM" or "EVMs") to the User ("User") in accordance with the terms and conditions set forth herein. Acceptance of the EVM is expressly subject to the following terms and conditions.
  - 1.1 EVMs are intended solely for product or software developers for use in a research and development setting to facilitate feasibility evaluation, experimentation, or scientific analysis of TI semiconductors products. EVMs have no direct function and are not finished products. EVMs shall not be directly or indirectly assembled as a part or subassembly in any finished product. For clarification, any software or software tools provided with the EVM ("Software") shall not be subject to the terms and conditions set forth herein but rather shall be subject to the applicable terms and conditions that accompany such Software
  - 1.2 EVMs are not intended for consumer or household use. EVMs may not be sold, sublicensed, leased, rented, loaned, assigned, or otherwise distributed for commercial purposes by Users, in whole or in part, or used in any finished product or production system.
2. *Limited Warranty and Related Remedies/Disclaimers:*
  - 2.1 These terms and conditions do not apply to Software. The warranty, if any, for Software is covered in the applicable Software License Agreement.
  - 2.2 TI warrants that the TI EVM will conform to TI's published specifications for ninety (90) days after the date TI delivers such EVM to User. Notwithstanding the foregoing, TI shall not be liable for any defects that are caused by neglect, misuse or mistreatment by an entity other than TI, including improper installation or testing, or for any EVMs that have been altered or modified in any way by an entity other than TI. Moreover, TI shall not be liable for any defects that result from User's design, specifications or instructions for such EVMs. Testing and other quality control techniques are used to the extent TI deems necessary or as mandated by government requirements. TI does not test all parameters of each EVM.
  - 2.3 If any EVM fails to conform to the warranty set forth above, TI's sole liability shall be at its option to repair or replace such EVM, or credit User's account for such EVM. TI's liability under this warranty shall be limited to EVMs that are returned during the warranty period to the address designated by TI and that are determined by TI not to conform to such warranty. If TI elects to repair or replace such EVM, TI shall have a reasonable time to repair such EVM or provide replacements. Repaired EVMs shall be warranted for the remainder of the original warranty period. Replaced EVMs shall be warranted for a new full ninety (90) day warranty period.
3. *Regulatory Notices:*
  - 3.1 *United States*
    - 3.1.1 *Notice applicable to EVMs not FCC-Approved:*

This kit is designed to allow product developers to evaluate electronic components, circuitry, or software associated with the kit to determine whether to incorporate such items in a finished product and software developers to write software applications for use with the end product. This kit is not a finished product and when assembled may not be resold or otherwise marketed unless all required FCC equipment authorizations are first obtained. Operation is subject to the condition that this product not cause harmful interference to licensed radio stations and that this product accept harmful interference. Unless the assembled kit is designed to operate under part 15, part 18 or part 95 of this chapter, the operator of the kit must operate under the authority of an FCC license holder or must secure an experimental authorization under part 5 of this chapter.
    - 3.1.2 *For EVMs annotated as FCC – FEDERAL COMMUNICATIONS COMMISSION Part 15 Compliant:*

### CAUTION

This device complies with part 15 of the FCC Rules. Operation is subject to the following two conditions: (1) This device may not cause harmful interference, and (2) this device must accept any interference received, including interference that may cause undesired operation.

Changes or modifications not expressly approved by the party responsible for compliance could void the user's authority to operate the equipment.

### FCC Interference Statement for Class A EVM devices

*NOTE: This equipment has been tested and found to comply with the limits for a Class A digital device, pursuant to part 15 of the FCC Rules. These limits are designed to provide reasonable protection against harmful interference when the equipment is operated in a commercial environment. This equipment generates, uses, and can radiate radio frequency energy and, if not installed and used in accordance with the instruction manual, may cause harmful interference to radio communications. Operation of this equipment in a residential area is likely to cause harmful interference in which case the user will be required to correct the interference at his own expense.*

## FCC Interference Statement for Class B EVM devices

*NOTE: This equipment has been tested and found to comply with the limits for a Class B digital device, pursuant to part 15 of the FCC Rules. These limits are designed to provide reasonable protection against harmful interference in a residential installation. This equipment generates, uses and can radiate radio frequency energy and, if not installed and used in accordance with the instructions, may cause harmful interference to radio communications. However, there is no guarantee that interference will not occur in a particular installation. If this equipment does cause harmful interference to radio or television reception, which can be determined by turning the equipment off and on, the user is encouraged to try to correct the interference by one or more of the following measures:*

- Reorient or relocate the receiving antenna.
- Increase the separation between the equipment and receiver.
- Connect the equipment into an outlet on a circuit different from that to which the receiver is connected.
- Consult the dealer or an experienced radio/TV technician for help.

### 3.2 Canada

#### 3.2.1 For EVMs issued with an Industry Canada Certificate of Conformance to RSS-210

##### **Concerning EVMs Including Radio Transmitters:**

This device complies with Industry Canada license-exempt RSS standard(s). Operation is subject to the following two conditions: (1) this device may not cause interference, and (2) this device must accept any interference, including interference that may cause undesired operation of the device.

##### **Concernant les EVMs avec appareils radio:**

Le présent appareil est conforme aux CNR d'Industrie Canada applicables aux appareils radio exempts de licence. L'exploitation est autorisée aux deux conditions suivantes: (1) l'appareil ne doit pas produire de brouillage, et (2) l'utilisateur de l'appareil doit accepter tout brouillage radioélectrique subi, même si le brouillage est susceptible d'en compromettre le fonctionnement.

##### **Concerning EVMs Including Detachable Antennas:**

Under Industry Canada regulations, this radio transmitter may only operate using an antenna of a type and maximum (or lesser) gain approved for the transmitter by Industry Canada. To reduce potential radio interference to other users, the antenna type and its gain should be so chosen that the equivalent isotropically radiated power (e.i.r.p.) is not more than that necessary for successful communication. This radio transmitter has been approved by Industry Canada to operate with the antenna types listed in the user guide with the maximum permissible gain and required antenna impedance for each antenna type indicated. Antenna types not included in this list, having a gain greater than the maximum gain indicated for that type, are strictly prohibited for use with this device.

##### **Concernant les EVMs avec antennes détachables**

Conformément à la réglementation d'Industrie Canada, le présent émetteur radio peut fonctionner avec une antenne d'un type et d'un gain maximal (ou inférieur) approuvé pour l'émetteur par Industrie Canada. Dans le but de réduire les risques de brouillage radioélectrique à l'intention des autres utilisateurs, il faut choisir le type d'antenne et son gain de sorte que la puissance isotrope rayonnée équivalente (p.i.r.e.) ne dépasse pas l'intensité nécessaire à l'établissement d'une communication satisfaisante. Le présent émetteur radio a été approuvé par Industrie Canada pour fonctionner avec les types d'antenne énumérés dans le manuel d'usage et ayant un gain admissible maximal et l'impédance requise pour chaque type d'antenne. Les types d'antenne non inclus dans cette liste, ou dont le gain est supérieur au gain maximal indiqué, sont strictement interdits pour l'exploitation de l'émetteur.

### 3.3 Japan

3.3.1 *Notice for EVMs delivered in Japan:* Please see [http://www.tij.co.jp/lstds/ti\\_ja/general/eStore/notice\\_01.page](http://www.tij.co.jp/lstds/ti_ja/general/eStore/notice_01.page) 日本国内に輸入される評価用キット、ボードについては、次のところをご覧ください。  
[http://www.tij.co.jp/lstds/ti\\_ja/general/eStore/notice\\_01.page](http://www.tij.co.jp/lstds/ti_ja/general/eStore/notice_01.page)

3.3.2 *Notice for Users of EVMs Considered "Radio Frequency Products" in Japan:* EVMs entering Japan may not be certified by TI as conforming to Technical Regulations of Radio Law of Japan.

If User uses EVMs in Japan, not certified to Technical Regulations of Radio Law of Japan, User is required by Radio Law of Japan to follow the instructions below with respect to EVMs:

1. Use EVMs in a shielded room or any other test facility as defined in the notification #173 issued by Ministry of Internal Affairs and Communications on March 28, 2006, based on Sub-section 1.1 of Article 6 of the Ministry's Rule for Enforcement of Radio Law of Japan,
2. Use EVMs only after User obtains the license of Test Radio Station as provided in Radio Law of Japan with respect to EVMs, or
3. Use of EVMs only after User obtains the Technical Regulations Conformity Certification as provided in Radio Law of Japan with respect to EVMs. Also, do not transfer EVMs, unless User gives the same notice above to the transferee. Please note that if User does not follow the instructions above, User will be subject to penalties of Radio Law of Japan.

【無線電波を送信する製品の開発キットをお使いになる際の注意事項】 開発キットの中には技術基準適合証明を受けていないものがあります。技術適合証明を受けていないものご使用に際しては、電波法遵守のため、以下のいずれかの措置を取っていただく必要がありますのでご注意ください。

1. 電波法施行規則第6条第1項第1号に基づく平成18年3月28日総務省告示第173号で定められた電波暗室等の試験設備でご使用いただく。
2. 実験局の免許を取得後ご使用いただく。
3. 技術基準適合証明を取得後ご使用いただく。

なお、本製品は、上記の「ご使用にあたっての注意」を譲渡先、移転先に通知しない限り、譲渡、移転できないものとします。

上記を遵守頂けない場合は、電波法の罰則が適用される可能性があることをご留意ください。日本テキサス・インスツルメンツ株式会社  
東京都新宿区西新宿 6 丁目 2 4 番 1 号  
西新宿三井ビル

3.3.3 *Notice for EVMs for Power Line Communication:* Please see [http://www.tij.co.jp/llds/ti\\_ja/general/eStore/notice\\_02.page](http://www.tij.co.jp/llds/ti_ja/general/eStore/notice_02.page)  
電力線搬送波通信についての開発キットをお使いになる際の注意事項については、次のところをご覧ください。[http://www.tij.co.jp/llds/ti\\_ja/general/eStore/notice\\_02.page](http://www.tij.co.jp/llds/ti_ja/general/eStore/notice_02.page)

#### 4 *EVM Use Restrictions and Warnings:*

4.1 EVMS ARE NOT FOR USE IN FUNCTIONAL SAFETY AND/OR SAFETY CRITICAL EVALUATIONS, INCLUDING BUT NOT LIMITED TO EVALUATIONS OF LIFE SUPPORT APPLICATIONS.

4.2 User must read and apply the user guide and other available documentation provided by TI regarding the EVM prior to handling or using the EVM, including without limitation any warning or restriction notices. The notices contain important safety information related to, for example, temperatures and voltages.

#### 4.3 *Safety-Related Warnings and Restrictions:*

4.3.1 User shall operate the EVM within TI's recommended specifications and environmental considerations stated in the user guide, other available documentation provided by TI, and any other applicable requirements and employ reasonable and customary safeguards. Exceeding the specified performance ratings and specifications (including but not limited to input and output voltage, current, power, and environmental ranges) for the EVM may cause personal injury or death, or property damage. If there are questions concerning performance ratings and specifications, User should contact a TI field representative prior to connecting interface electronics including input power and intended loads. Any loads applied outside of the specified output range may also result in unintended and/or inaccurate operation and/or possible permanent damage to the EVM and/or interface electronics. Please consult the EVM user guide prior to connecting any load to the EVM output. If there is uncertainty as to the load specification, please contact a TI field representative. During normal operation, even with the inputs and outputs kept within the specified allowable ranges, some circuit components may have elevated case temperatures. These components include but are not limited to linear regulators, switching transistors, pass transistors, current sense resistors, and heat sinks, which can be identified using the information in the associated documentation. When working with the EVM, please be aware that the EVM may become very warm.

4.3.2 EVMs are intended solely for use by technically qualified, professional electronics experts who are familiar with the dangers and application risks associated with handling electrical mechanical components, systems, and subsystems. User assumes all responsibility and liability for proper and safe handling and use of the EVM by User or its employees, affiliates, contractors or designees. User assumes all responsibility and liability to ensure that any interfaces (electronic and/or mechanical) between the EVM and any human body are designed with suitable isolation and means to safely limit accessible leakage currents to minimize the risk of electrical shock hazard. User assumes all responsibility and liability for any improper or unsafe handling or use of the EVM by User or its employees, affiliates, contractors or designees.

4.4 User assumes all responsibility and liability to determine whether the EVM is subject to any applicable international, federal, state, or local laws and regulations related to User's handling and use of the EVM and, if applicable, User assumes all responsibility and liability for compliance in all respects with such laws and regulations. User assumes all responsibility and liability for proper disposal and recycling of the EVM consistent with all applicable international, federal, state, and local requirements.

5. *Accuracy of Information:* To the extent TI provides information on the availability and function of EVMS, TI attempts to be as accurate as possible. However, TI does not warrant the accuracy of EVM descriptions, EVM availability or other information on its websites as accurate, complete, reliable, current, or error-free.

6. *Disclaimers:*
- 6.1 EXCEPT AS SET FORTH ABOVE, EVMS AND ANY WRITTEN DESIGN MATERIALS PROVIDED WITH THE EVM (AND THE DESIGN OF THE EVM ITSELF) ARE PROVIDED "AS IS" AND "WITH ALL FAULTS." TI DISCLAIMS ALL OTHER WARRANTIES, EXPRESS OR IMPLIED, REGARDING SUCH ITEMS, INCLUDING BUT NOT LIMITED TO ANY IMPLIED WARRANTIES OF MERCHANTABILITY OR FITNESS FOR A PARTICULAR PURPOSE OR NON-INFRINGEMENT OF ANY THIRD PARTY PATENTS, COPYRIGHTS, TRADE SECRETS OR OTHER INTELLECTUAL PROPERTY RIGHTS.
- 6.2 EXCEPT FOR THE LIMITED RIGHT TO USE THE EVM SET FORTH HEREIN, NOTHING IN THESE TERMS AND CONDITIONS SHALL BE CONSTRUED AS GRANTING OR CONFERRING ANY RIGHTS BY LICENSE, PATENT, OR ANY OTHER INDUSTRIAL OR INTELLECTUAL PROPERTY RIGHT OF TI, ITS SUPPLIERS/LICENSORS OR ANY OTHER THIRD PARTY, TO USE THE EVM IN ANY FINISHED END-USER OR READY-TO-USE FINAL PRODUCT, OR FOR ANY INVENTION, DISCOVERY OR IMPROVEMENT MADE, CONCEIVED OR ACQUIRED PRIOR TO OR AFTER DELIVERY OF THE EVM.
7. *USER'S INDEMNITY OBLIGATIONS AND REPRESENTATIONS.* USER WILL DEFEND, INDEMNIFY AND HOLD TI, ITS LICENSORS AND THEIR REPRESENTATIVES HARMLESS FROM AND AGAINST ANY AND ALL CLAIMS, DAMAGES, LOSSES, EXPENSES, COSTS AND LIABILITIES (COLLECTIVELY, "CLAIMS") ARISING OUT OF OR IN CONNECTION WITH ANY HANDLING OR USE OF THE EVM THAT IS NOT IN ACCORDANCE WITH THESE TERMS AND CONDITIONS. THIS OBLIGATION SHALL APPLY WHETHER CLAIMS ARISE UNDER STATUTE, REGULATION, OR THE LAW OF TORT, CONTRACT OR ANY OTHER LEGAL THEORY, AND EVEN IF THE EVM FAILS TO PERFORM AS DESCRIBED OR EXPECTED.
8. *Limitations on Damages and Liability:*
- 8.1 *General Limitations.* IN NO EVENT SHALL TI BE LIABLE FOR ANY SPECIAL, COLLATERAL, INDIRECT, PUNITIVE, INCIDENTAL, CONSEQUENTIAL, OR EXEMPLARY DAMAGES IN CONNECTION WITH OR ARISING OUT OF THESE TERMS AND CONDITIONS OR THE USE OF THE EVMS PROVIDED HEREUNDER, REGARDLESS OF WHETHER TI HAS BEEN ADVISED OF THE POSSIBILITY OF SUCH DAMAGES. EXCLUDED DAMAGES INCLUDE, BUT ARE NOT LIMITED TO, COST OF REMOVAL OR REINSTALLATION, ANCILLARY COSTS TO THE PROCUREMENT OF SUBSTITUTE GOODS OR SERVICES, RETESTING, OUTSIDE COMPUTER TIME, LABOR COSTS, LOSS OF GOODWILL, LOSS OF PROFITS, LOSS OF SAVINGS, LOSS OF USE, LOSS OF DATA, OR BUSINESS INTERRUPTION. NO CLAIM, SUIT OR ACTION SHALL BE BROUGHT AGAINST TI MORE THAN ONE YEAR AFTER THE RELATED CAUSE OF ACTION HAS OCCURRED.
- 8.2 *Specific Limitations.* IN NO EVENT SHALL TI'S AGGREGATE LIABILITY FROM ANY WARRANTY OR OTHER OBLIGATION ARISING OUT OF OR IN CONNECTION WITH THESE TERMS AND CONDITIONS, OR ANY USE OF ANY TI EVM PROVIDED HEREUNDER, EXCEED THE TOTAL AMOUNT PAID TO TI FOR THE PARTICULAR UNITS SOLD UNDER THESE TERMS AND CONDITIONS WITH RESPECT TO WHICH LOSSES OR DAMAGES ARE CLAIMED. THE EXISTENCE OF MORE THAN ONE CLAIM AGAINST THE PARTICULAR UNITS SOLD TO USER UNDER THESE TERMS AND CONDITIONS SHALL NOT ENLARGE OR EXTEND THIS LIMIT.
9. *Return Policy.* Except as otherwise provided, TI does not offer any refunds, returns, or exchanges. Furthermore, no return of EVM(s) will be accepted if the package has been opened and no return of the EVM(s) will be accepted if they are damaged or otherwise not in a resalable condition. If User feels it has been incorrectly charged for the EVM(s) it ordered or that delivery violates the applicable order, User should contact TI. All refunds will be made in full within thirty (30) working days from the return of the components(s), excluding any postage or packaging costs.
10. *Governing Law:* These terms and conditions shall be governed by and interpreted in accordance with the laws of the State of Texas, without reference to conflict-of-laws principles. User agrees that non-exclusive jurisdiction for any dispute arising out of or relating to these terms and conditions lies within courts located in the State of Texas and consents to venue in Dallas County, Texas. Notwithstanding the foregoing, any judgment may be enforced in any United States or foreign court, and TI may seek injunctive relief in any United States or foreign court.

Mailing Address: Texas Instruments, Post Office Box 655303, Dallas, Texas 75265  
Copyright © 2015, Texas Instruments Incorporated

## IMPORTANT NOTICE

Texas Instruments Incorporated and its subsidiaries (TI) reserve the right to make corrections, enhancements, improvements and other changes to its semiconductor products and services per JESD46, latest issue, and to discontinue any product or service per JESD48, latest issue. Buyers should obtain the latest relevant information before placing orders and should verify that such information is current and complete. All semiconductor products (also referred to herein as "components") are sold subject to TI's terms and conditions of sale supplied at the time of order acknowledgment.

TI warrants performance of its components to the specifications applicable at the time of sale, in accordance with the warranty in TI's terms and conditions of sale of semiconductor products. Testing and other quality control techniques are used to the extent TI deems necessary to support this warranty. Except where mandated by applicable law, testing of all parameters of each component is not necessarily performed.

TI assumes no liability for applications assistance or the design of Buyers' products. Buyers are responsible for their products and applications using TI components. To minimize the risks associated with Buyers' products and applications, Buyers should provide adequate design and operating safeguards.

TI does not warrant or represent that any license, either express or implied, is granted under any patent right, copyright, mask work right, or other intellectual property right relating to any combination, machine, or process in which TI components or services are used. Information published by TI regarding third-party products or services does not constitute a license to use such products or services or a warranty or endorsement thereof. Use of such information may require a license from a third party under the patents or other intellectual property of the third party, or a license from TI under the patents or other intellectual property of TI.

Reproduction of significant portions of TI information in TI data books or data sheets is permissible only if reproduction is without alteration and is accompanied by all associated warranties, conditions, limitations, and notices. TI is not responsible or liable for such altered documentation. Information of third parties may be subject to additional restrictions.

Resale of TI components or services with statements different from or beyond the parameters stated by TI for that component or service voids all express and any implied warranties for the associated TI component or service and is an unfair and deceptive business practice. TI is not responsible or liable for any such statements.

Buyer acknowledges and agrees that it is solely responsible for compliance with all legal, regulatory and safety-related requirements concerning its products, and any use of TI components in its applications, notwithstanding any applications-related information or support that may be provided by TI. Buyer represents and agrees that it has all the necessary expertise to create and implement safeguards which anticipate dangerous consequences of failures, monitor failures and their consequences, lessen the likelihood of failures that might cause harm and take appropriate remedial actions. Buyer will fully indemnify TI and its representatives against any damages arising out of the use of any TI components in safety-critical applications.

In some cases, TI components may be promoted specifically to facilitate safety-related applications. With such components, TI's goal is to help enable customers to design and create their own end-product solutions that meet applicable functional safety standards and requirements. Nonetheless, such components are subject to these terms.

No TI components are authorized for use in FDA Class III (or similar life-critical medical equipment) unless authorized officers of the parties have executed a special agreement specifically governing such use.

Only those TI components which TI has specifically designated as military grade or "enhanced plastic" are designed and intended for use in military/aerospace applications or environments. Buyer acknowledges and agrees that any military or aerospace use of TI components which have **not** been so designated is solely at the Buyer's risk, and that Buyer is solely responsible for compliance with all legal and regulatory requirements in connection with such use.

TI has specifically designated certain components as meeting ISO/TS16949 requirements, mainly for automotive use. In any case of use of non-designated products, TI will not be responsible for any failure to meet ISO/TS16949.

### Products

Audio	<a href="http://www.ti.com/audio">www.ti.com/audio</a>
Amplifiers	<a href="http://amplifier.ti.com">amplifier.ti.com</a>
Data Converters	<a href="http://dataconverter.ti.com">dataconverter.ti.com</a>
DLP® Products	<a href="http://www.dlp.com">www.dlp.com</a>
DSP	<a href="http://dsp.ti.com">dsp.ti.com</a>
Clocks and Timers	<a href="http://www.ti.com/clocks">www.ti.com/clocks</a>
Interface	<a href="http://interface.ti.com">interface.ti.com</a>
Logic	<a href="http://logic.ti.com">logic.ti.com</a>
Power Mgmt	<a href="http://power.ti.com">power.ti.com</a>
Microcontrollers	<a href="http://microcontroller.ti.com">microcontroller.ti.com</a>
RFID	<a href="http://www.ti-rfid.com">www.ti-rfid.com</a>
OMAP Applications Processors	<a href="http://www.ti.com/omap">www.ti.com/omap</a>
Wireless Connectivity	<a href="http://www.ti.com/wirelessconnectivity">www.ti.com/wirelessconnectivity</a>

### Applications

Automotive and Transportation	<a href="http://www.ti.com/automotive">www.ti.com/automotive</a>
Communications and Telecom	<a href="http://www.ti.com/communications">www.ti.com/communications</a>
Computers and Peripherals	<a href="http://www.ti.com/computers">www.ti.com/computers</a>
Consumer Electronics	<a href="http://www.ti.com/consumer-apps">www.ti.com/consumer-apps</a>
Energy and Lighting	<a href="http://www.ti.com/energy">www.ti.com/energy</a>
Industrial	<a href="http://www.ti.com/industrial">www.ti.com/industrial</a>
Medical	<a href="http://www.ti.com/medical">www.ti.com/medical</a>
Security	<a href="http://www.ti.com/security">www.ti.com/security</a>
Space, Avionics and Defense	<a href="http://www.ti.com/space-avionics-defense">www.ti.com/space-avionics-defense</a>
Video and Imaging	<a href="http://www.ti.com/video">www.ti.com/video</a>

### TI E2E Community

[e2e.ti.com](http://e2e.ti.com)