

NHD-C0216AZ-FN-GBW

COG (Chip-on-Glass) Liquid Crystal Display Module

NHD- Newhaven Display
C0216- COG, 2 Lines x 16 Characters
AZ- Model
F- Transflective
N- No Backlight
G- STN Positive Gray
B- 6:00 Optimal View
W- Wide Temp
RoHS Compliant

Newhaven Display International, Inc.

2661 Galvin Ct.

Elgin IL, 60124

Ph: 847-844-8795

Fax: 847-844-8796

www.newhavendisplay.com

nhtech@newhavendisplay.com

nhsales@newhavendisplay.com

Document Revision History

Revision	Date	Description	Changed by
0	7/20/07	Initial Release	-
1	8/1/07	Edit temp. range errors	CL
2	6/4/08	Edit incorrect pinout	CL
3	9/9/09	User guide reformat	BE
4	10/9/09	Updated Electrical Characteristics information	MC
5	10/15/09	Updated Block Diagram	MC
6	6/2/11	Timing characteristics updated	AK
7	4/14/17	Updated Mechanical Drawing	TM
8	7/5/19	Added PCB Footprint Drawing	AS
9	1/30/20	Glass Panel Updated	SB

Functions and Features

- 2 lines x 16 characters
- Built-in NT7605 controller
- 5x8 dots with cursor
- +5V power supply
- 1/16 duty, 1/5 bias
- RoHS Compliant

1	2	3	4	5	6	7	8	
				SYMBOL	REVISION			DATE

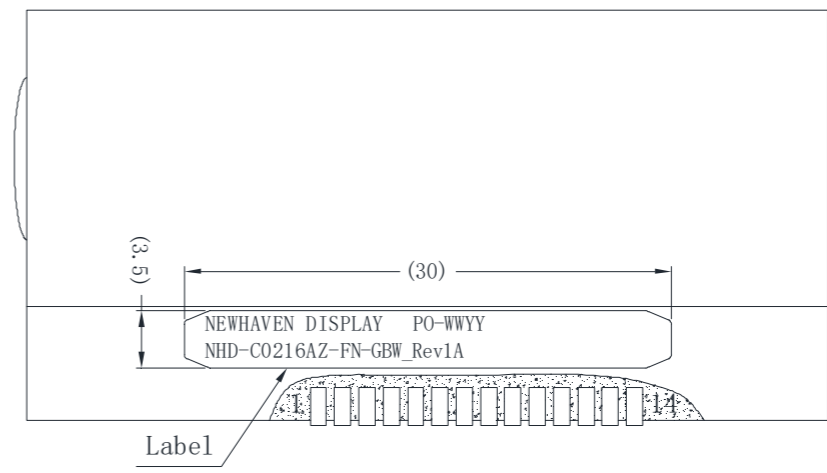
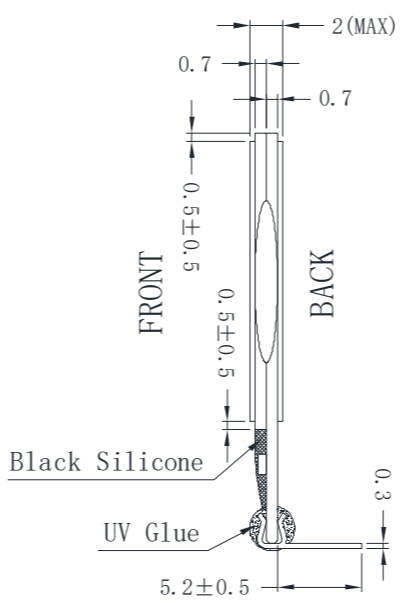
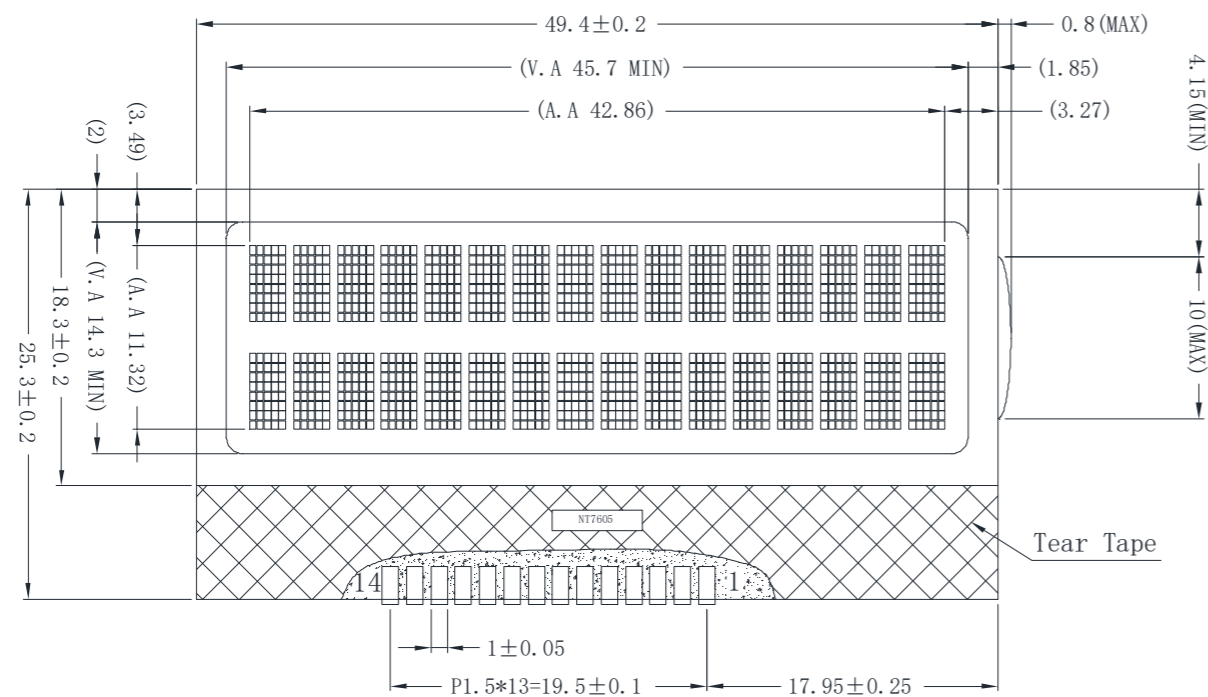

Pin assignment	
NO.	Symbol
1	VSS
2	V0
3	VDD
4	RS
5	R/W
6	E
7	D0
8	D1
9	D2
10	D3
11	D4
12	D5
13	D6
14	D7

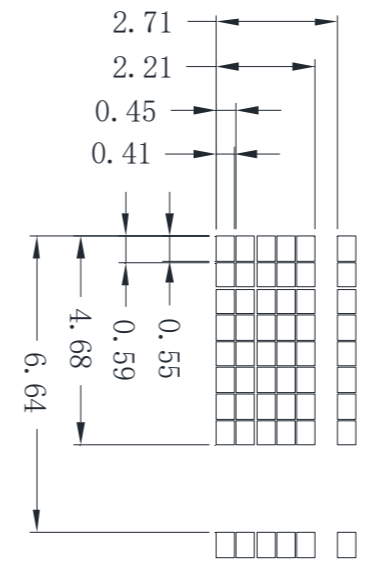
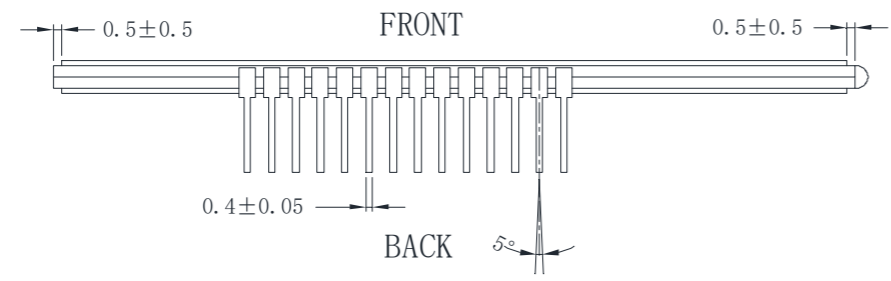

- Notes:**
- Driving: 1/16 Duty, 1/5 Bias
 - Voltage: 5.0V VDD, 4.7V VLCD
 - Display View: STN Gray Positive / Transflective
 - Optimal View: 6:00
 - Backlight: No Backlight
 - Driver IC: NT7605H 4-bit / 8-bit MCU Interface

STANDARD TOLERANCE: (UNLESS OTHERWISE SPECIFIED)		
LINEAR: ±0.3mm	DRAWING/PART NUMBER: NHD-C0216AZ-FN-GBW	REVISION: 1A
UNLESS OTHERWISE SPECIFIED: - DIMENSIONS ARE IN MILLIMETERS - THIRD ANGLE PROJECTION	DRAWN BY: S. Baxi	APPROVED BY: S. Baxi
	DRAWN DATE: 1/30/20	APPROVED DATE: 1/30/20
	DO NOT SCALE DRAWING	
	SHEET 1 OF 1	
THIS DRAWING IS SOLELY THE PROPERTY OF NEWHAVEN DISPLAY INTERNATIONAL, INC. THE INFORMATION IT CONTAINS IS NOT TO BE DISCLOSED, REPRODUCED OR COPIED IN WHOLE OR PART WITHOUT WRITTEN APPROVAL FROM NEWHAVEN DISPLAY.		

Recommended PCB Footprint

SYMBOL	REVISION	DATE

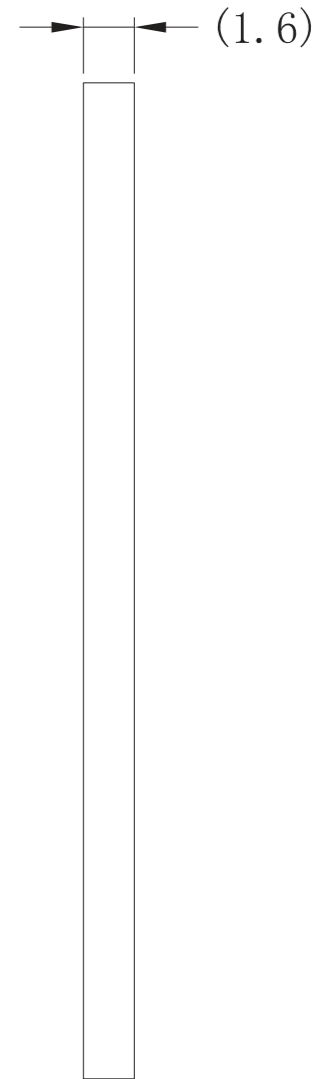
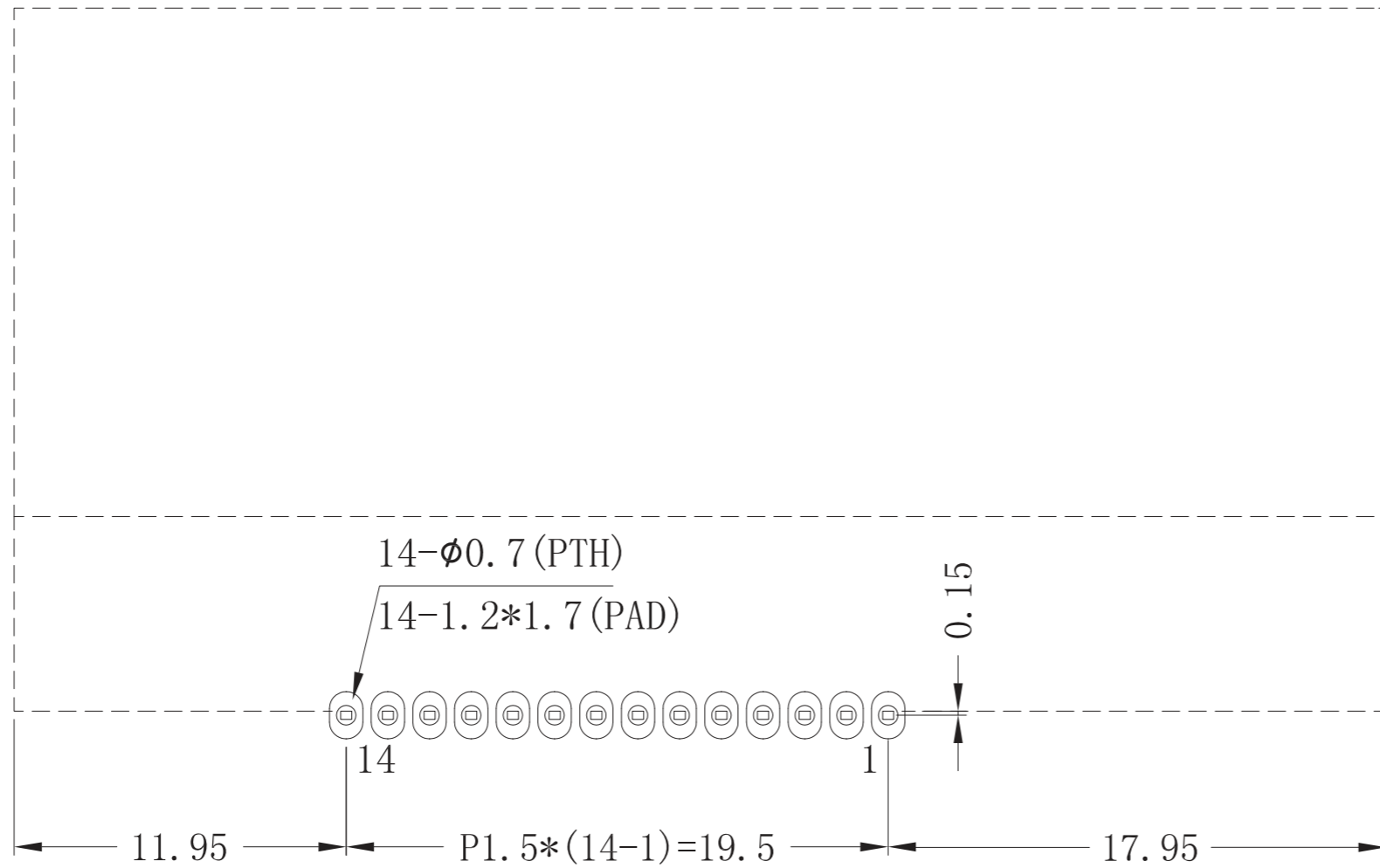

Applicable Displays:
 1) NHD-C0216AZ-FN-GBW

STANDARD TOLERANCE: (UNLESS OTHERWISE SPECIFIED)		
	LINEAR: $\pm 0.3\text{mm}$	REVISION: 1.0
UNLESS OTHERWISE SPECIFIED: - DIMENSIONS ARE IN MILLIMETERS - THIRD ANGLE PROJECTION	DRAWING/PART NUMBER: NHD-C0216AZ-FN-Footprint	
	DRAWN BY: A. Shah	APPROVED BY: A. Khan
	DRAWN DATE: 7/3/19	APPROVED DATE: 7/3/19
	DO NOT SCALE DRAWING	SHEET 1 OF 1
THIS DRAWING IS SOLELY THE PROPERTY OF NEWHAVEN DISPLAY INTERNATIONAL, INC. THE INFORMATION IT CONTAINS IS NOT TO BE DISCLOSED, REPRODUCED OR COPIED IN WHOLE OR PART WITHOUT WRITTEN APPROVAL FROM NEWHAVEN DISPLAY.		

Pin Description and Wiring Diagram

Pin No.	Symbol	External Connection	Function Description
1	V _{SS}	Power Supply	Ground
2	V ₀	Adj. Power supply	Power supply for contrast (approx. 0.3V)
3	V _{DD}	Power Supply	Supply voltage for logic (5.0V)
4	RS	MPU	Register select signal. RS=0: Command, RS=1: Data
5	R/W	MPU	Read/Write select signal, R/W=1: Read R/W=0: Write
6	E	MPU	Operation enable signal. Falling edge triggered.
7-10	DB0-DB3		Four low order bi-directional three state data bus lines. These four are not used during 4-bit operation.
11-14	DB4-DB7		Four high order bi-directional three state data bus lines.

Recommended LCD connector: 1.5 mm pitch, 14 pins Soldered to PCB

Recommended Breakout Board: [NHD-PCB40](#)

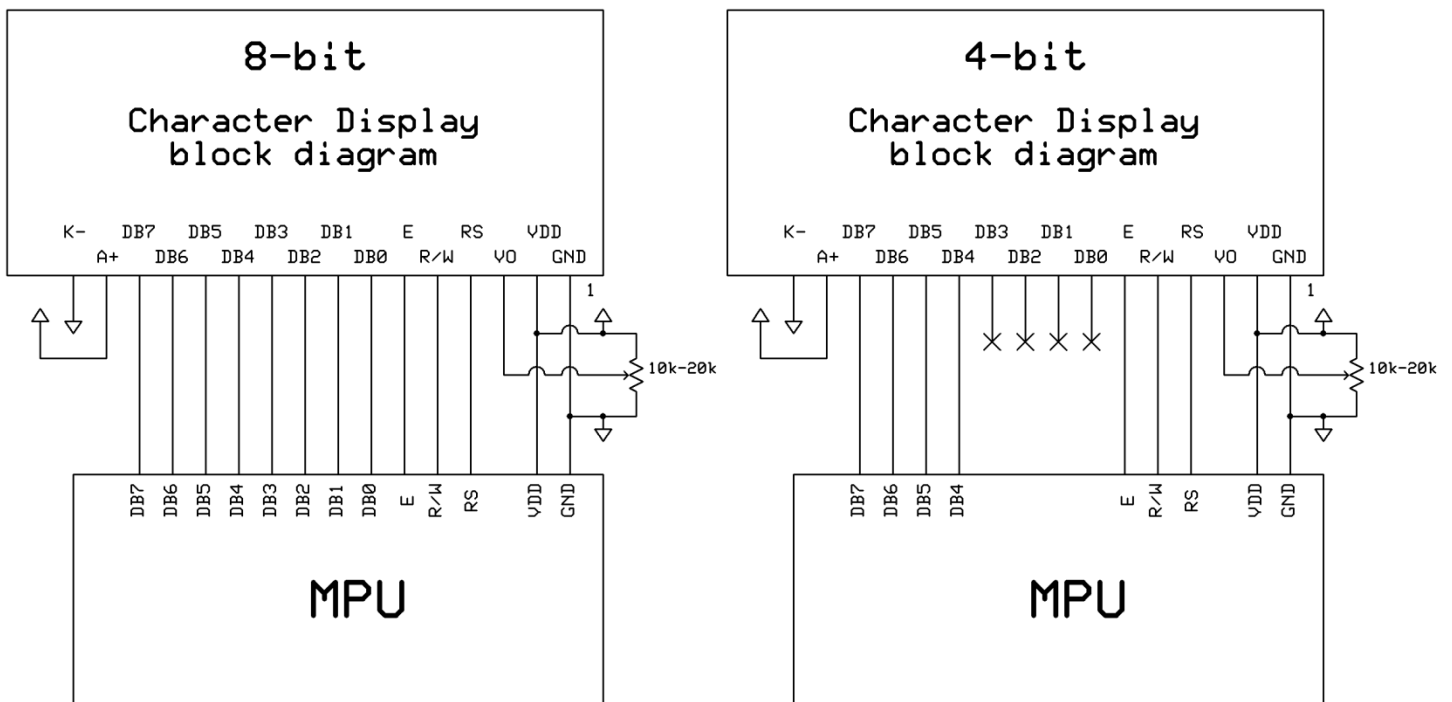

Electrical Characteristics

Item	Symbol	Condition	Min.	Typ.	Max.	Unit
Operating Temperature Range	T _{OP}	Absolute Max	-20	-	+70	°C
Storage Temperature Range	T _{ST}	Absolute Max	-30	-	+80	°C
Supply Voltage	V _{DD}	-	4.5	5.0	5.5	V
Supply Current	I _{DD}	T _{OP} = 25°C, V _{DD} = 5.0V	0.6	1.83	2.8	mA
Supply for LCD (contrast)	V _{LCD}		4.4	4.7	5.0	V
"H" Level input	V _{IH}	-	0.8 * V _{DD}	-	V _{DD}	V
"L" Level input	V _{IL}	-	V _{SS}	-	0.2 * V _{DD}	V
"H" Level output	V _{OH}	-	V _{DD} - 0.8	-	V _{DD}	V
"L" Level output	V _{OL}	-	V _{SS}	-	V _{SS} + 0.4	V

Optical Characteristics

Item	Symbol	Condition	Min.	Typ.	Max.	Unit
Optimal Viewing Angles	Top	CR ≥ 2	-	35	-	°
	Bottom		-	60	-	°
	Left		-	40	-	°
	Right		-	40	-	°
Contrast Ratio	CR	-	2	4	-	-
Response Time	Rise	T _{OP} = 25°C	-	150	250	ms
	Fall		-	150	250	ms

Controller Information

Built-in NT7605 Controller.

Please download specification at http://www.newhavendisplay.com/app_notes/NT7605.pdf

DDRAM address location:

1	2	3	4	5	6	7	8	9	10	11	12	13	14	15	16
00	01	02	03	04	05	06	07	08	09	0A	0B	0C	0D	0E	0F
40	41	42	43	44	45	46	47	48	49	4A	4B	4C	4D	4E	4F

Table of Commands

Instruction	Code										Function	Execution time (max) (fosc = 250KHz)
	RS	RW	DB7	DB6	DB5	DB4	DB3	DB2	DB1	DB0		
Display Clear	0	0	0	0	0	0	0	0	0	1	Clear entire display area, Restore display from shift, and load address counter with DD RAM address 00H.	1.64ms
Display/ Cursor Home	0	0	0	0	0	0	0	0	0	1	Restore display from shift and load address counter with DD RAM address 00H.	1.64ms
Entry Mode Set	0	0	0	0	0	0	0	1	I/D	S	Specify direction of cursor movement and display shift mode. This operation takes place after each data transfer (read/write).	40µs
Display ON/OFF	0	0	0	0	0	0	1	D	C	B	Specify activation of display (D) cursor (C) and blinking of character at cursor position (B).	40µs
Display/ Cursor Shift	0	0	0	0	0	1	S/C	R/L	*	*	Shift display or move cursor.	40µs
Function Set	0	0	0	0	1	DL	N	F	*	*	Set interface data length (DL), number of display line (N), and character font (F).	40µs
RAM Address Set	0	0	0	1	ACG						Load the address counter with a CG RAM address. Subsequent data access is for CG RAM data.	40µs
DD RAM Address Set	0	0	1	ADD						Load the address counter with a DD RAM address. Subsequent data access is for DD RAM data.	40µs	
Busy Flag/ Address Counter Read	0	1	BF	AC						Read Busy Flag (BF) and contents of Address Counter (AC).	1µs	
CG RAM/ DD RAM Data Write	1	0	Write data								Write data to CG RAM or DD RAM.	40µs
CG RAM/ DD RAM Data Read	1	1	Read data								Read data from CG RAM or DD RAM.	40µs
	I/D = 1 : Increment I/D = 0 : Decrement S = 1 : Display Shift On D = 1 : Display On C = 1 : Cursor Display On B = 1 : Cursor Blink On S/C = 1 : Shift Display S/C = 0 : Move Cursor R/L = 1 : Shift Right R/L = 0 : Shift Left DL = 1 : 8-Bit DL = 0 : 4-Bit N = 1 : Dual Line N = 0 : Signal Line F = 1 : 5x10 dots F = 0 : 5x8 dots BF = 1 : Internal Operation BF = 0 : Ready for Instruction										DD RAM : Display Data RAM CG RAM : Character Generator RAM ACG : Character Generator RAM Address ADD : Display Data RAM Address AC : Address Counter	

Timing Characteristics

Read Operation

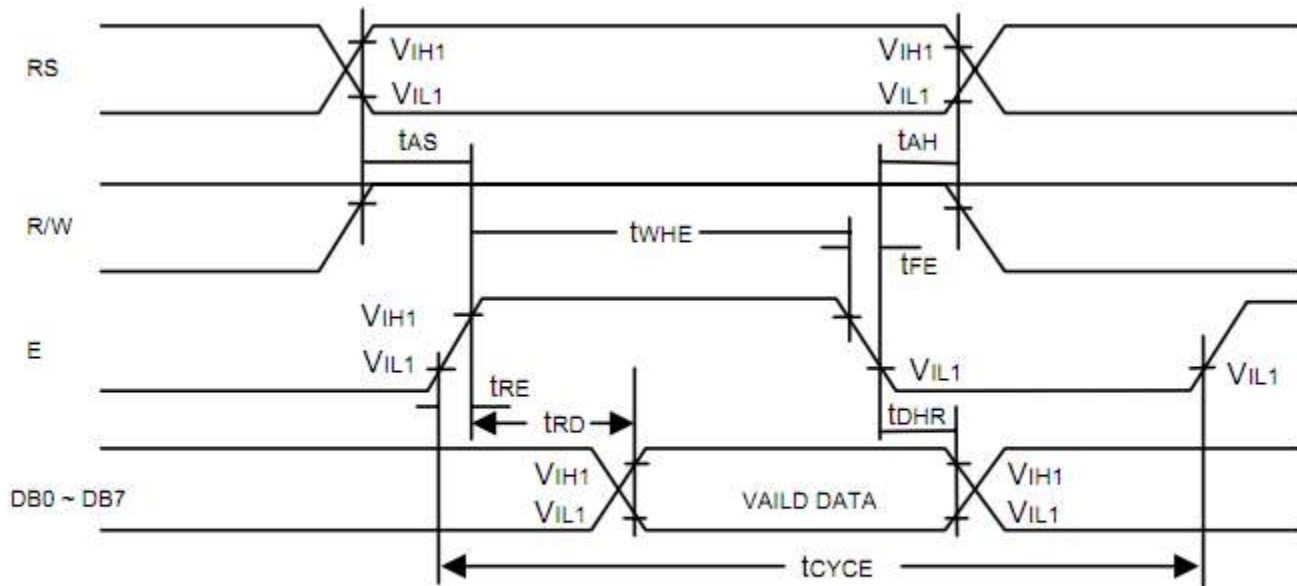

Figure 1. Bus Read Operation Sequence
(Reading out data from NT7605 to MPU)

Read Cycle ($V_{DD} = 5.0V$, $GND = 0V$, $T_A = 25^\circ C$)

Symbol	Parameter	Min.	Typ.	Max.	Unit	Conditions
t_{CYCE}	Enable Cycle Time	500	-	-	ns	Figure 1
t_{wHE}	Enable "H" Level Pulse Width	300	-	-	ns	Figure 1
t_{RE}, t_{FE}	Enable Rise/Fall Time	-	-	25	ns	Figure 1
t_{AS}	RS, R/W Setup Time	60 ¹	-	-	ns	Figure 1
		100 ²				
t_{AH}	RS, R/W Address Hold Time	10	-	-	ns	Figure 1
t_{RD}	Read Data Output Delay	-	-	190	ns	Figure 1
t_{DHR}	Read Data Hold Time	20	-	-	ns	Figure 1

Notes: 1: 8-bit operation mode
2: 4-bit operation mode

Write Operation

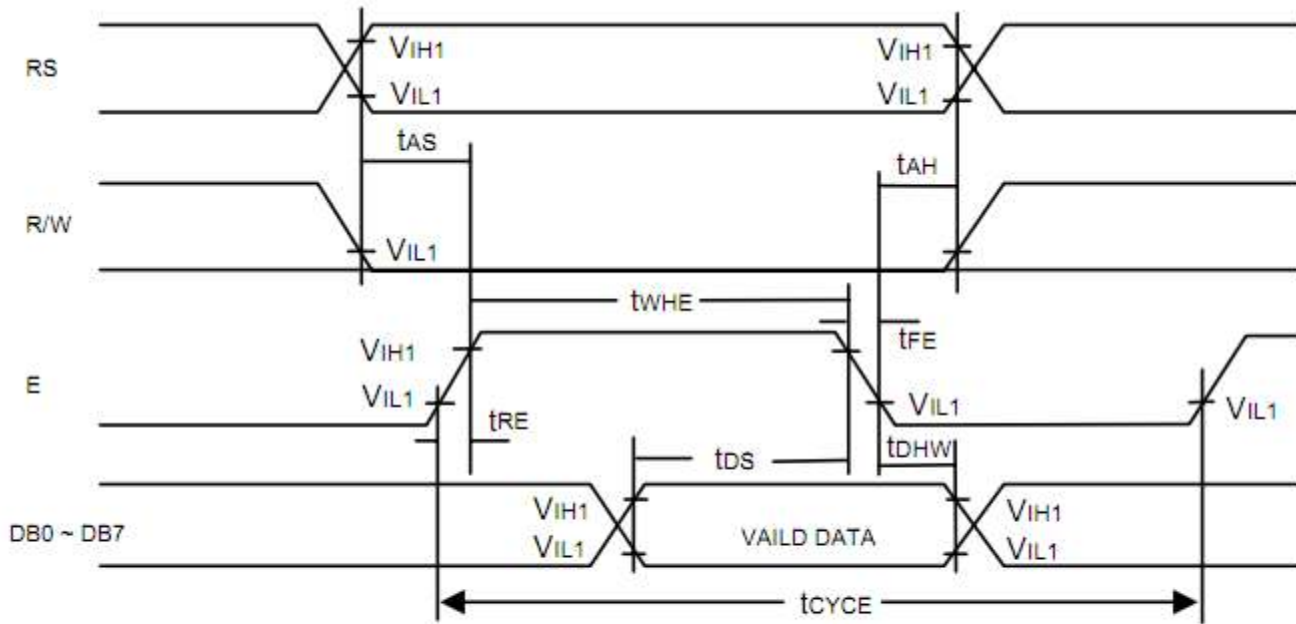

Figure 2. Bus Write Operation Sequence
(Writing data from MPU to NT7605)

Write Cycle ($V_{DD} = 5.0V$, $GND = 0V$, $T_A = 25^\circ C$)

Symbol	Parameter	Min.	Typ.	Max.	Unit	Conditions
t_{CYCE}	Enable Cycle Time	500	-	-	ns	Figure 2
t_{WHE}	Enable "H" Level Pulse Width	300	-	-	ns	Figure 2
t_{RE} , t_{FE}	Enable Rise/Fall Time	-	-	25	ns	Figure 2
t_{AS}	RS, R/W Setup Time	60^1	-	-	ns	Figure 2
		100^2				
t_{AH}	RS, R/W Address Hold Time	10	-	-	ns	Figure 2
t_{DS}	Data Output Delay	100	-	-	ns	Figure 2
t_{DHW}	Data Hold Time	10	-	-	ns	Figure 2

Notes: 1: 8-bit operation mode
2: 4-bit operation mode

Built-in Font Table

Lower 4 Bits \ Upper 4 Bits	0000	0001	0010	0011	0100	0101	0110	0111	1000	1001	1010	1011	1100	1101	1110	1111
xxxx0000	CG RAM (1)			0	a	P	`	P				-	夕	ミ	α	ρ
xxxx0001	(2)		!	1	A	Q	a	q			。	ア	チ	△	ä	q
xxxx0010	(3)		"	2	B	R	b	r			「	イ	ツ	×	ß	θ
xxxx0011	(4)		#	3	C	S	c	s			」	ウ	テ	モ	ε	∞
xxxx0100	(5)		\$	4	D	T	d	t			、	エ	ト	ト	μ	Ω
xxxx0101	(6)		%	5	E	U	e	u			・	オ	ナ	1	σ	ü
xxxx0110	(7)		&	6	F	V	f	v			ヲ	カ	ニ	ヨ	ρ	Σ
xxxx0111	(8)		'	7	G	W	g	w			ア	キ	ヌ	ラ	g	π
xxxx1000	(1)		<	8	H	X	h	x			イ	ク	ネ	リ	γ	∞
xxxx1001	(2)		>	9	I	Y	i	y			ウ	ケ	ル	ル	ˆ	γ
xxxx1010	(3)		*	:	J	Z	j	z			エ	コ	ハ	レ	j	≠
xxxx1011	(4)		+	;	K	[k	{			オ	サ	ヒ	ロ	*	≠
xxxx1100	(5)		,	<	L	¥	l	l			カ	シ	フ	ク	φ	≠
xxxx1101	(6)		-	=	M]	m	}			ユ	ス	ハ	ン	≠	÷
xxxx1110	(7)		.	>	N	^	n	→			ヨ	セ	ホ	°	≠	
xxxx1111	(8)		/	?	O	_	o	+			ッ	ソ	マ	°	ö	■

Example Initialization Program

```
'INIT-----
A = &H30
Call Writecom                                     'wake up
Waitms 100
Call Writecom                                     'wake up
Waitms 10
Call Writecom                                     'wake up
Waitms 10
A = &H38
'function set
Call Writecom
A = &H10
'shift display=no
Call Writecom
A = &H0C
'display on
Call Writecom
A = &H06
'entry mode set
Call Writecom
'-----
Sub Writecom
P1 = A
Reset P3.0
'instruction
Reset P3.7
'RW
Waitms 1
Set P3.4
'E
Waitms 1
Reset P3.4                                     'E
End Sub
'-----
Sub Writedata
P1 = A
Set P3.0
'data
Reset P3.7
'RW
Waitms 1
Set P3.4
'E
Waitms 1
Reset P3.4                                     'E
End Sub
'-----
```

Quality Information

Test Item	Content of Test	Test Condition	Note
High Temperature storage	Endurance test applying the high storage temperature for a long time.	+80°C, 96 Hrs.	2
Low Temperature storage	Endurance test applying the low storage temperature for a long time.	-30°C, 96 Hrs.	1,2
High Temperature Operation	Endurance test applying the electric stress (voltage & current) and the high thermal stress for a long time.	+70°C, 96 Hrs.	2
Low Temperature Operation	Endurance test applying the electric stress (voltage & current) and the low thermal stress for a long time.	-20°C, 96 Hrs.	1,2
High Temperature / Humidity Operation	Endurance test applying the electric stress (voltage & current) and the high thermal with high humidity stress for a long time.	+50°C, 90% RH, 96 Hrs.	1,2
Thermal Shock resistance	Endurance test applying the electric stress (voltage & current) during a cycle of low and high thermal stress.	0°C, 30min -> 25°C, 5min -> 50°C, 30min = 1 cycle For 10 cycles	
Vibration test	Endurance test applying vibration to simulate transportation and use.	10-55Hz, 1.5mm amplitude. 60 sec in each of 3 directions X, Y, Z For 15 minutes	3
Static electricity test	Endurance test applying electric static discharge. (5 Times)	Air: ±8KV Contact: ±4KV C: 150pF R: 330Ω	

Note 1: No condensation to be observed.

Note 2: Conducted after 4 hours of storage at 25°C, 0%RH.

Note 3: Test performed on product itself, not inside a container.

Precautions for using LCDs/LCMs

See Precautions at www.newhavendisplay.com/specs/precautions.pdf

Warranty Information and Terms & Conditions

http://www.newhavendisplay.com/index.php?main_page=terms