

PRODUCT NO.
10150097-3200RLF

PCB LAYOUT PROPOSAL

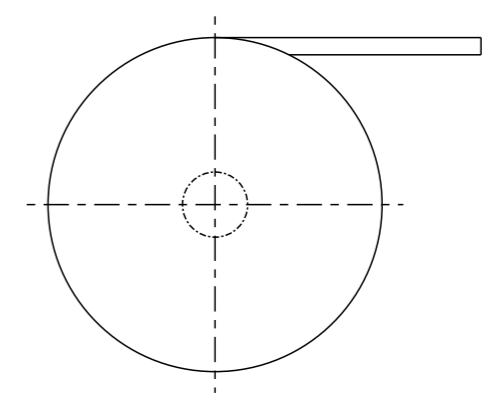
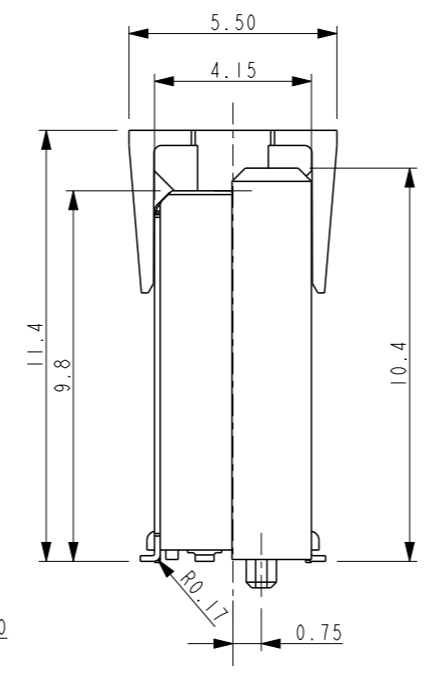
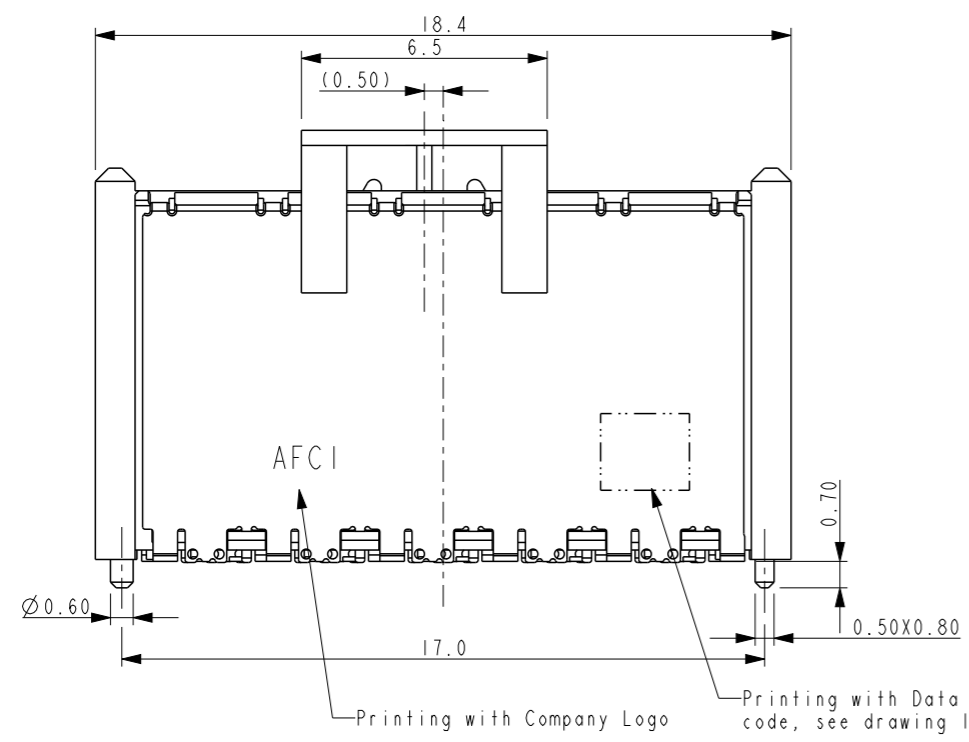
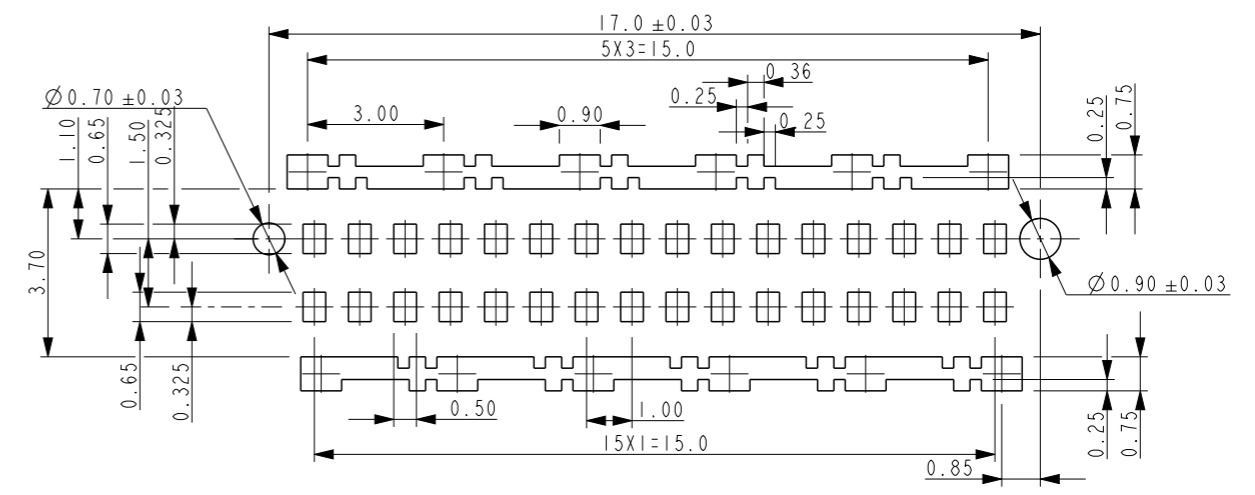
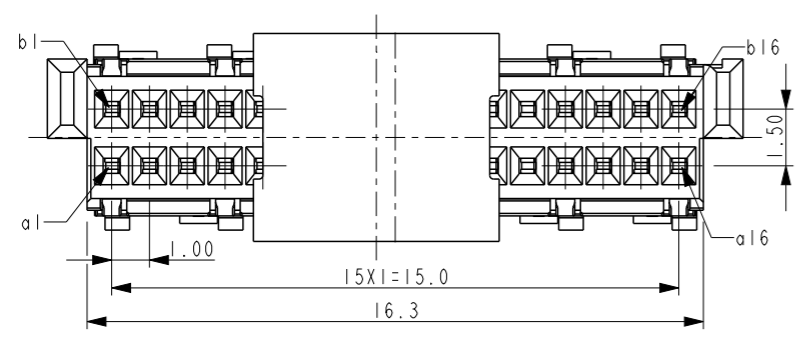

Package Description:
1. External diameter of Reel: Ø330
2. Leader 400mm/ Trailer 160mm
3. Packaging unit: 390 pcs/Reel

Reel off direction
→

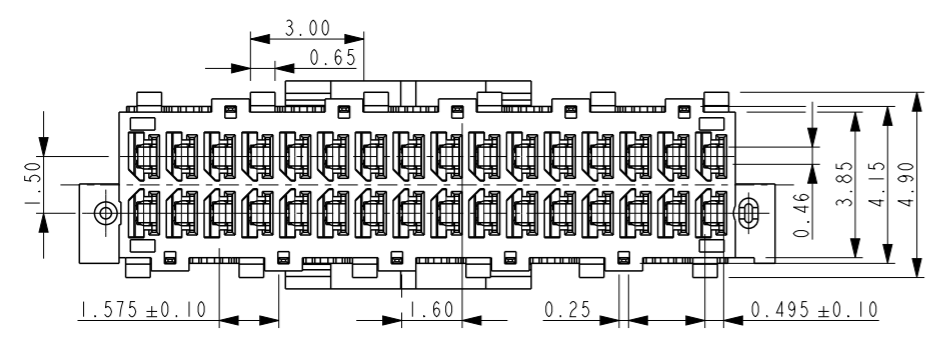
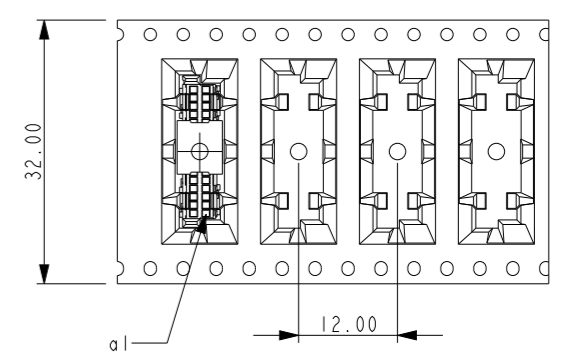

Note

1. Material:
 - 1.1 Housing and Cap: LCP 30%GF, E130I Black, Ticona
 - 2.2 Terminal and shield: CuSn6
2. Plating: 1-3µm Ni under plating, 2-4µm Sn on solder area, 0.65 µm PdNi, 0.10µm Au on mating area.
3. Coplanarity area of Termination 0.10mm Max (/1)

- (/1) Inspection level 1: control chart required
Proof of process capability or 100% test if process capability is not achieved
- (/2) Inspection level 2 and 3: control chart required
Proof of mean value, standard deviation and machine capability
- (/3) Proof of values or proof of attributive test

spec ref	*	dr	Hao-Liang Sun	2018/11/27	projection	mm	size	A3	scale	5:1	
tolerance std	TOLERANCES UNLESS OTHERWISE SPECIFIED	eng	LI-Qing Lei	2022/12/12			ecn no	ELX-N-45883-1			
		chr	-	-			rel level	Released			
surface	linear	appr	Tim Yao	2022/12/14	product family		dwg no	10150097		rev	C
ASME Y14.5	angular								Product - Customer Drw	sheet 1 of 1	
	0.X										
	0.XX										
	0.XXX										
	0°										
	±0.20										
	±0.10										
	±0.05										
	±2°										



Female 10mm SMD 32 pos
Microspeed Vertical Series

Amphenol FCI

© 2020 Amphenol Corporation