

NOTES: UNLESS OTHERWISE SPECIFIED
 1. ALL DIMENSIONS FOR REFERENCE ONLY.
 2. OUTPUT SHAFT DIRECTION IS REVERSIBLE.
 3. MOTOR IS NOT DESIGNED FOR STALL.

SCALE 2:3

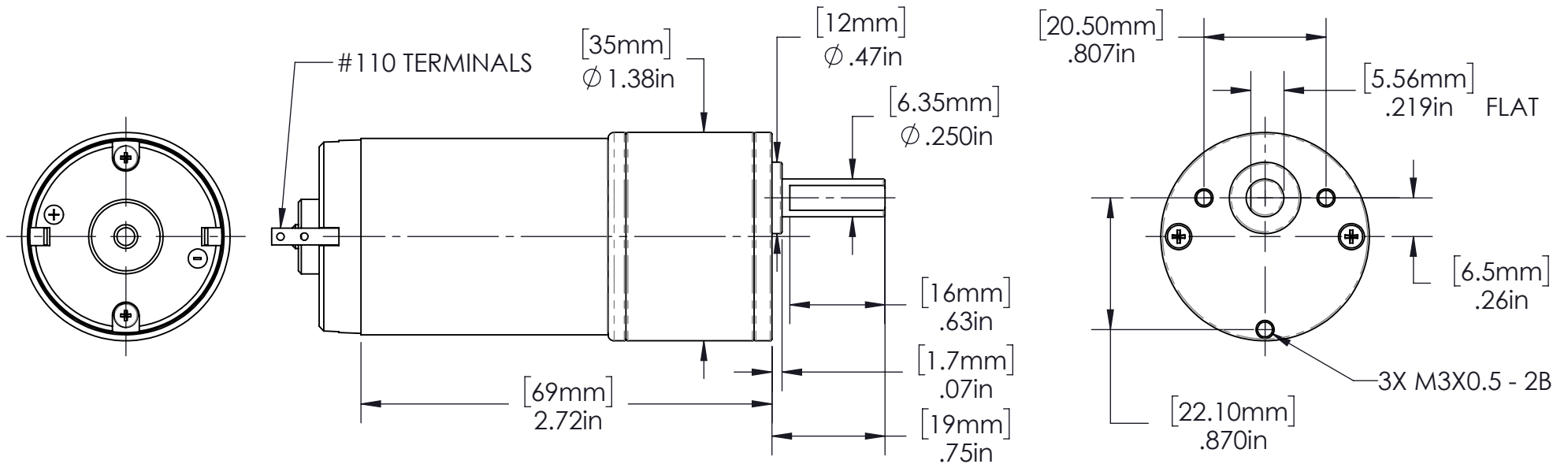
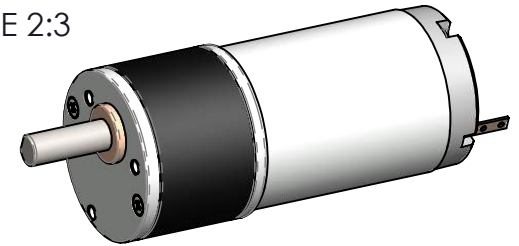

DCM-1019-12	12	20 RPM	65 OZ-IN	0.25 AMPS
DCM-1019-24	24	40 RPM	65 OZ-IN	0.30 AMPS
PART #	VOLTS	SPEED	TORQUE	CURRENT

I/WE CERTIFY THAT SAMPLES OF THIS MOTOR HAVE BEEN FULLY TESTED BY THE UNDERSIGNED AND THAT ALL SPECIFICATIONS HAVE BEEN REVIEWED FOR PRODUCTION. MULTIPRODUCTS COMPANY, INC. IS NOT RESPONSIBLE FOR MOTORS THAT FAIL IN THE FIELD DUE TO INSUFFICIENT TESTING OF THE SAMPLE MOTORS. I/WE AGREE TO PROVIDE MULTIPRODUCTS COMPANY, INC. WITH CURRENT DRAWINGS AND IN-HOUSE TEST PROCEDURES AS THEY BECOME AVAILABLE. ANY CHANGES THAT I/WE MAY MAKE WHICH OCCUR AFTER THE DATE SHOWN ARE SUBJECT TO REVIEW AND MAY AFFECT UNIT PRICE AND/OR DELIVERY DATES.

SIGNATURE _____ PRINT NAME _____ DATE _____
 IN ORDER TO BEGIN PRODUCTION, MULTIPRODUCTS COMPANY, INC. MUST HAVE SIGNED APPROVAL.

A	ADDED DCM-1019-24, REDRAWN	5/15/2013	
REV.	DESCRIPTION	DATE	ECO#

TOLERANCES

X.XX: ±010
 X.XXX: ±005
 FRACTION: ±1/64
 ANGLE: ±2°
 UNLESS OTHERWISE SPECIFIED



MULTI PRODUCTS
 Company, Inc.

PART NAME/DESCRIPTION: **DC GEARHEAD MOTOR**

DRAWN BY: DAB	DATE: 5/9/2012	SCALE: 1:1	MATERIAL: VARIOUS
CHK'D BY: RP	DATE: 5/10/2012	PART NUMBER: MOD-DCM-1019	
APPR'D BY: -	DATE:		