

RIGHT ANGLE PLUG CRIMP TYPE

R199.005.240

CABLE 2/50

Series : MC-CARD

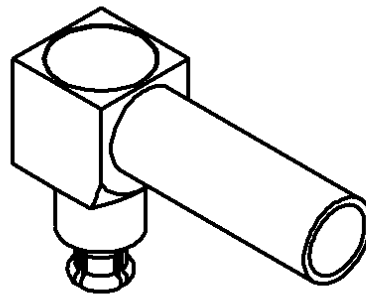
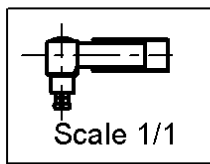
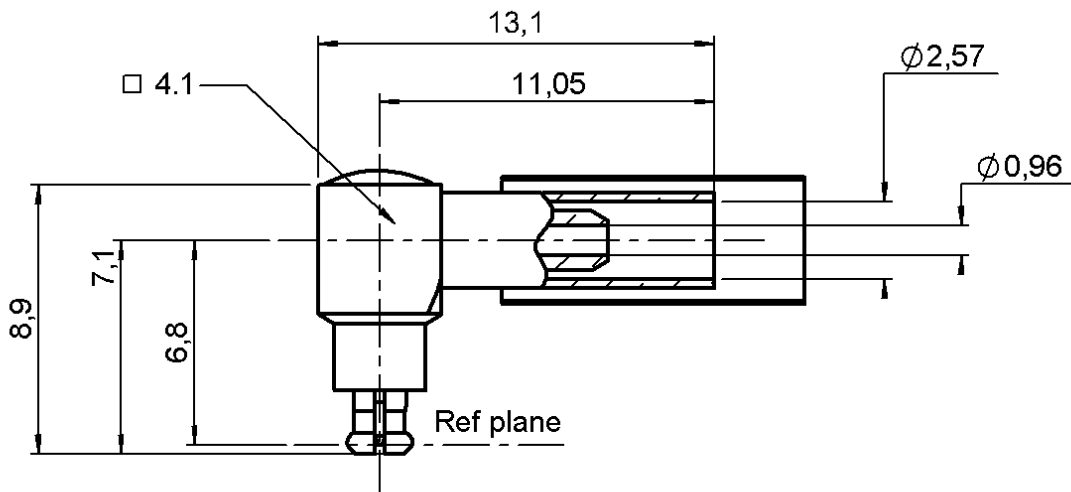

All dimensions are in mm.

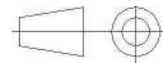

COMPONENTS	MATERIALS	PLATINGS (µm)
BODY	BRASS	NICKEL 2
CENTER CONTACT	BRASS	GOLD 0.5 OVER NICKEL 2
OUTER CONTACT	BERYLLIUM COPPER	.GOLD 1.3 OVER NICKEL 2
INSULATOR	PTFE	
GASKET	-	
OTHERS PARTS	BRASS	NICKEL 2
-	-	-
-	-	-

Issue : 0742 B

In the effort to improve our products, we reserve the right to make changes judged to be necessary.



RIGHT ANGLE PLUG CRIMP TYPE

R199.005.240

CABLE 2/50

Series : MC-CARD

PACKAGING

Standard	Unit	Other
100	-	Contact us

SPECIFICATION

ELECTRICAL CHARACTERISTICS

Impedance		50 Ω
Frequency		0-8 GHz
VSWR	1.15 +	0,0150 x F(GHz) Maxi
Insertion loss		.07 √F(GHz) dB Maxi
RF leakage	- (65 - F(GHz)) dB Maxi
Voltage rating		170 Veff Maxi
Dielectric withstanding voltage		500 Veff mini
Insulation resistance		5000 MΩ mini

CABLE ASSEMBLY

Stripping	a	b	c	d	e	f
mm	2,00	6,00	8,00	0,00	0,00	0,00

Assembly instruction : **Crimp 05**

Recommended cable(s)
 RG 178
 RG 196
 RG 178 LC
 KX 21

Cable retention
 - pull off **58** N mini
 - torque **NA** N.cm

MECHANICAL CHARACTERISTICS

Center contact retention		
Axial force – Mating end	10	N mini
Axial force – Opposite end	10	N mini
Torque	NA	N.cm mini

TOOLING

Part Number	Description	Hexagon
.	.	.
R282.211.000	CRIMPING TOOL	2.67
R282.293.000	CRIMPING TOOL M22520/5-01	
R282.235.003	CRIMPING DIES	2.67

Recommended torque		
Mating	NA	N.cm
Panel nut	NA	N.cm
Clamp nut	NA	N.cm
A/F clamp nut	0,0000	mm

Mating life	1000	Cycles mini
Weight	0,8900	g

OTHERS CHARACTERISTICS

-

ENVIRONMENTAL

Operating temperature	-65/+165	° C
Hermetic seal	NA	Atm.cm3/s
Panel leakage	NA	

Issue : 0742 B

In the effort to improve our products, we reserve the right to make changes judged to be necessary.

