

# STANDARD 14-20 AWG: 9177-000

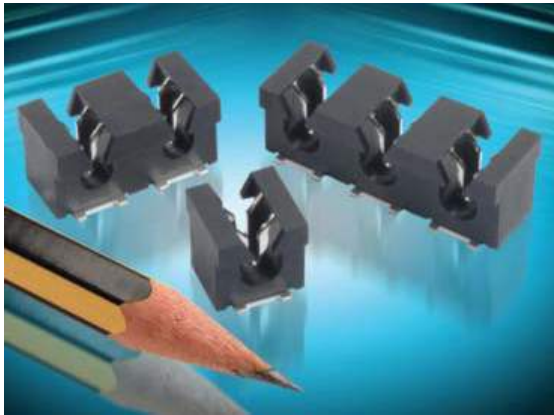

## General Information



The 917X series of surface mount Insulation Displacement Connectors (IDC) were developed to meet the harsh requirements of automotive and industrial applications. This industry proven series of connectors provides a robust, reliable, and efficient method to connect individual wires ranging from 12 AWG to 30 AWG directly to a PCB. The single contact design can function as a standalone component. It provides our designers access to IDC technology in an easy-to-use form factor allowing them to bring power and signal to a PCB in a wide range of applications. These connectors have been tested to various levels of shock, vibration, and temperature cycling to prove their reliability and robustness. The simplicity of inserting a wire into an SMT contact with a small tool or optional retention / termination cap allows a wide range of devices to be connected to the PCB without soldering. The IDC contact provides a gas-tight connection to the wire and the optional cap provides a positive strain relief even in the harshest conditions. In case of repair, the wires can be removed and replaced up to three times.

The 9177 series accepts 14 AWG to 20 AWG wires with an insulation diameter ranging from 2.75mm to 4.25mm. These dual contact connectors support a 16 amp current rating with two large SMT solder tails per wire to provide maximum stability on the PCB. Available in 1p-3p configuration, these connectors can be end stackable for higher pin counts.

### APPLICATIONS

- Connecting discrete wire components directly to the PCB
- Bringing power and signals onto a PCB
- Daisy chaining PCB's together to create a continuous string of boards
- Application Notes: refer to 201-01-124
- Specification Notes: refer to 201-01-109

### FEATURES AND BENEFITS

- IDC contact provides a gas-tight connection to the PCB for long term reliability
- Connector housing captures the wire insulation for positive strain relief
- Tested to various levels of shock, vibration, and temperature cycling for reliability
- Low and high volume assembly tools to match production volumes
- Reduced total applied cost versus solder or crimp processes
- High temperature insulator capable to 260°C reflow soldering processes

### ELECTRICAL

- Current Rating: Up to 16 Amp / Contact
- Voltage Rating: 600 VAC (RMS) or DC Equivalent

### ENVIRONMENTAL

- Operating Temperature: -40°C to +125°C (UL rated to +120°C)
- Storage Temperature: -40°C to +70°C

### MECHANICAL

- Insulator Material: Nylon 46: UL94V-0
- Contact Material: Phosphor Bronze
- Plating: Tin over Nickel
- Durability: 3 Cycles

### HOW TO ORDER

<b>00</b> Prefix	<b>9177</b> Series	<b>00X</b> Number of Ways	<b>0XX</b> Wire Gauge Size	<b>X</b> Color/Approval	<b>06</b> Plating Option																																				
		<table border="1"> <thead> <tr> <th>Code</th> <th>No of Ways</th> <th>Details</th> </tr> </thead> <tbody> <tr> <td>001</td> <td>1</td> <td>Page 62</td> </tr> <tr> <td>002</td> <td>2</td> <td>Page 63</td> </tr> <tr> <td>003</td> <td>3</td> <td>Page 64</td> </tr> </tbody> </table>	Code	No of Ways	Details	001	1	Page 62	002	2	Page 63	003	3	Page 64	<table border="1"> <thead> <tr> <th>Code</th> <th>Accepted Wire Gauge</th> <th>Wire Insulation</th> </tr> </thead> <tbody> <tr> <td>001</td> <td>14 AWG Solid or Stranded</td> <td>Ø 4.25</td> </tr> <tr> <td>012</td> <td>16 AWG Solid or Stranded</td> <td>Ø 3.50</td> </tr> <tr> <td>022</td> <td>18 AWG Solid or Stranded</td> <td>Ø 3.50</td> </tr> <tr> <td>033</td> <td>20 AWG Solid or Stranded</td> <td>Ø 2.75</td> </tr> </tbody> </table>	Code	Accepted Wire Gauge	Wire Insulation	001	14 AWG Solid or Stranded	Ø 4.25	012	16 AWG Solid or Stranded	Ø 3.50	022	18 AWG Solid or Stranded	Ø 3.50	033	20 AWG Solid or Stranded	Ø 2.75	<table border="1"> <thead> <tr> <th>Code</th> <th>Color</th> <th>Approval</th> </tr> </thead> <tbody> <tr> <td>8</td> <td>Black</td> <td>UL APPROVED</td> </tr> <tr> <td>9</td> <td>White</td> <td>Standard - UL APPROVED</td> </tr> </tbody> </table>	Code	Color	Approval	8	Black	UL APPROVED	9	White	Standard - UL APPROVED	<p>06 = Pure Tin all Over</p>
Code	No of Ways	Details																																							
001	1	Page 62																																							
002	2	Page 63																																							
003	3	Page 64																																							
Code	Accepted Wire Gauge	Wire Insulation																																							
001	14 AWG Solid or Stranded	Ø 4.25																																							
012	16 AWG Solid or Stranded	Ø 3.50																																							
022	18 AWG Solid or Stranded	Ø 3.50																																							
033	20 AWG Solid or Stranded	Ø 2.75																																							
Code	Color	Approval																																							
8	Black	UL APPROVED																																							
9	White	Standard - UL APPROVED																																							



### HOW TO ORDER – CAP OPTIONS – THROUGH WIRE

<b>60</b> Prefix 60 = Cap	<b>9177</b> Series	<b>00X</b> Number of Ways	<b>0XX</b> Wire Gauge Size	<b>X00</b> Insulator Color																														
		<table border="1"> <thead> <tr> <th>Code</th> <th>No of Ways</th> </tr> </thead> <tbody> <tr> <td>001</td> <td>1</td> </tr> <tr> <td>002</td> <td>2</td> </tr> <tr> <td>003</td> <td>3</td> </tr> </tbody> </table>	Code	No of Ways	001	1	002	2	003	3	<table border="1"> <thead> <tr> <th>Code</th> <th>Wire Insulator Diameter (Note 3)</th> <th>A</th> <th>B</th> </tr> </thead> <tbody> <tr> <td>027</td> <td>2.10mm - 2.75mm</td> <td>Ø2.75</td> <td>2.00</td> </tr> <tr> <td>035</td> <td>2.75mm - 3.50mm</td> <td>Ø3.50</td> <td>2.65</td> </tr> <tr> <td>042</td> <td>3.50mm - 4.25mm</td> <td>Ø4.25</td> <td>3.40</td> </tr> </tbody> </table>	Code	Wire Insulator Diameter (Note 3)	A	B	027	2.10mm - 2.75mm	Ø2.75	2.00	035	2.75mm - 3.50mm	Ø3.50	2.65	042	3.50mm - 4.25mm	Ø4.25	3.40	<table border="1"> <thead> <tr> <th>Code</th> <th>Color</th> </tr> </thead> <tbody> <tr> <td>000</td> <td>Black</td> </tr> <tr> <td>100</td> <td>White</td> </tr> </tbody> </table>	Code	Color	000	Black	100	White
Code	No of Ways																																	
001	1																																	
002	2																																	
003	3																																	
Code	Wire Insulator Diameter (Note 3)	A	B																															
027	2.10mm - 2.75mm	Ø2.75	2.00																															
035	2.75mm - 3.50mm	Ø3.50	2.65																															
042	3.50mm - 4.25mm	Ø4.25	3.40																															
Code	Color																																	
000	Black																																	
100	White																																	

### HOW TO ORDER – CAP OPTIONS – WIRE STOP

<b>60</b> Prefix 60 = Cap	<b>9177</b> Series	<b>00X</b> Number of Ways	<b>0XX</b> Wire Gauge Size	<b>X00</b> Insulator Color																														
		<table border="1"> <thead> <tr> <th>Code</th> <th>No of Ways</th> </tr> </thead> <tbody> <tr> <td>001</td> <td>1</td> </tr> <tr> <td>002</td> <td>2</td> </tr> <tr> <td>003</td> <td>3</td> </tr> </tbody> </table>	Code	No of Ways	001	1	002	2	003	3	<table border="1"> <thead> <tr> <th>Code</th> <th>Wire Insulator Diameter (Note 3)</th> <th>A</th> <th>B</th> </tr> </thead> <tbody> <tr> <td>027</td> <td>2.10mm - 2.75mm</td> <td>Ø2.75</td> <td>2.00</td> </tr> <tr> <td>035</td> <td>2.75mm - 3.50mm</td> <td>Ø3.50</td> <td>2.65</td> </tr> <tr> <td>042</td> <td>3.50mm - 4.25mm</td> <td>Ø4.25</td> <td>3.40</td> </tr> </tbody> </table>	Code	Wire Insulator Diameter (Note 3)	A	B	027	2.10mm - 2.75mm	Ø2.75	2.00	035	2.75mm - 3.50mm	Ø3.50	2.65	042	3.50mm - 4.25mm	Ø4.25	3.40	<table border="1"> <thead> <tr> <th>Code</th> <th>Color</th> </tr> </thead> <tbody> <tr> <td>099</td> <td>Black</td> </tr> <tr> <td>199</td> <td>White</td> </tr> </tbody> </table>	Code	Color	099	Black	199	White
Code	No of Ways																																	
001	1																																	
002	2																																	
003	3																																	
Code	Wire Insulator Diameter (Note 3)	A	B																															
027	2.10mm - 2.75mm	Ø2.75	2.00																															
035	2.75mm - 3.50mm	Ø3.50	2.65																															
042	3.50mm - 4.25mm	Ø4.25	3.40																															
Code	Color																																	
099	Black																																	
199	White																																	

UL 1059 File No. E320991

# STANDARD 14-20 AWG: 9177-000

## General Information



### CONNECTOR/TOOLING PART NUMBER MATRIX

AWG	Wire Insulation	SERIES 9177 IDC			HAND INSERTION TOOLING*		ACCESSORY CAPS	
		Positions	Color	Part Number	Plastic (low volume)	Metal (high volume)	Through Wire	Wire Stop
14	Ø 4.25	1p	White	009177001001106	069177701601001	069177701701001	609177001042100	609177001042199
		1p	Black	009177001001006			609177001042000	609177001042099
		2p	White	009177002001106	069177701601002	069177701701002	609177002042100	609177002042199
		2p	Black	009177002001006			609177002042000	609177002042099
		3p	White	009177003001106	069177701601003	069177701701003	609177003042100	609177003042199
		3p	Black	009177003001006			609177003042000	609177003042099
16	Ø 3.50	1p	White	009177001012106	069177701602001	069177701702001	609177001035100	609177001035199
		1p	Black	009177001012006			609177001035000	609177001035099
		2p	White	009177002012106	069177701602002	069177701702002	609177002035100	609177002035199
		2p	Black	009177002012006			609177002035000	609177002035099
		3p	White	009177003012106	069177701602003	069177701702003	609177003035100	609177003035199
		3p	Black	009177003012006			609177003035000	609177003035099
18	Ø 3.50	1p	White	009177001022106	069177701602001	069177701702001	609177001035100	609177001035199
		1p	Black	009177001022006			609177001035000	609177001035099
		2p	White	009177002022106	069177701602002	069177701702002	609177002035100	609177002035199
		2p	Black	009177002022006			609177002035000	609177002035099
		3p	White	009177003022106	069177701602003	069177701702003	609177003035100	609177003035199
		3p	Black	009177003022006			609177003035000	609177003035099
20	Ø 2.75	1p	White	009177001033106	069177701603001	069177701703001	609177001027100	609177001027199
		1p	Black	009177001033006			609177001027000	609177001027099
		2p	White	009177002033106	069177701603002	069177701703002	609177002027100	609177002027199
		2p	Black	009177002033006			609177002027000	609177002027099
		3p	White	009177003033106	069177701603003	069177701703003	609177003027100	609177003027199
		3p	Black	009177003033006			609177003027000	609177003027099

\* Insertion Tooling - Requires Hand Press with Plates; Consult Application Notes 201-01-124

# STANDARD 14-20 AWG: 9177-000

## 1 Position

### 14-20 AWG 1 WAY IDC CONNECTOR



Pick and place area 2.375 x 9.00mm MIN

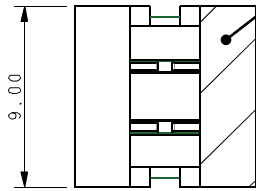

**NOTES:**

1. CONNECTOR FOR IDC WIRE TO BOARD CONNECTION.
2. CONTACT MATERIAL: PHOSPHOR BRONZE. INSULATION MATERIAL: HIGH TEMP NYLON 46, COLOUR REFER TO PAGE 60.
3. CONNECTOR DESIGNED TO ACCEPT BETWEEN 14AWG AND 20AWG SOLID AND STRANDED WIRE.
4. ALL DIMENSIONS  $\pm 0.20$  UNLESS TOLERANCED
5. FOR FULL PRODUCT SPECIFICATION ON STANDARD CONNECTORS REFER TO SPEC 201-01-109.
6. APPLICATION NOTES 201-01-124
7. FOR UL PRODUCT CODES UL REFERENCE E320991.
8. FOR PCB SPACE RESTRICTED BY ASSEMBLY TOOLING REFER TO PAGE 67

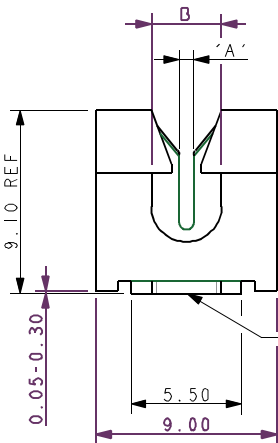

ALL TAILS TO BE WITHIN 0.10mm COPLANARITY.

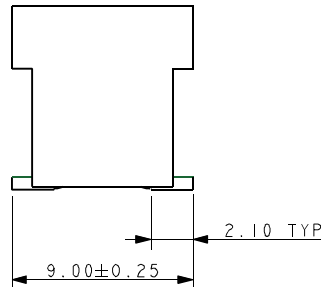

Code	Accepted Wire Gauge	A	Wire Insulation	B
001	14 AWG Solid or Stranded	1.10	Ø 4.25 max	4.25
012	16 AWG Solid or Stranded	0.82	Ø 3.50 max	3.50
022	18 AWG Solid or Stranded	0.72	Ø 3.50 max	3.50
033	20 AWG Solid or Stranded	0.60	Ø 2.75 max	2.75

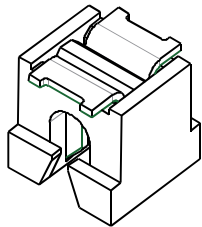
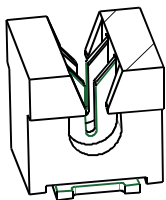

### SMT PCB LAYOUT PURE TIN PADS

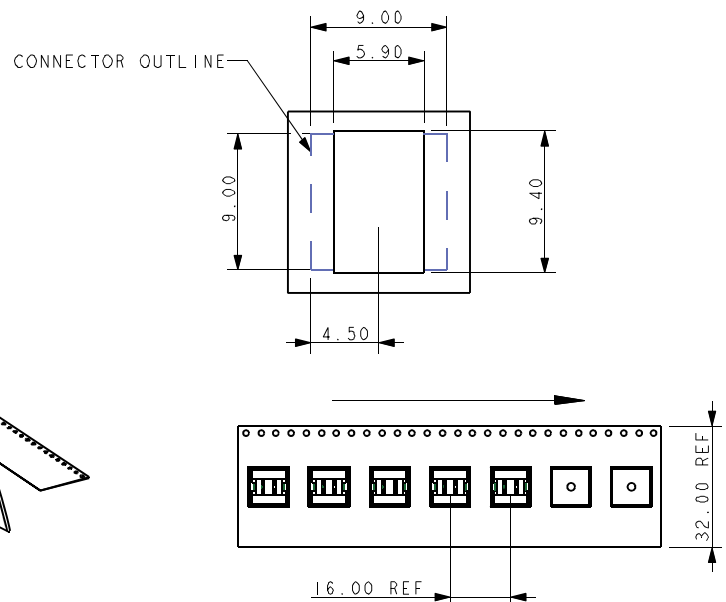

### PACKING DETAILS

REEL QTY	400
LEADER	500MM
TRAILER	400MM
REEL/BOX	4
PACK QTY	1600

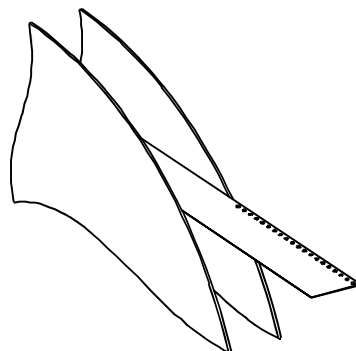

# STANDARD 14-20 AWG: 9177-000

## 2 Position

### 14-20 AWG 2 WAY IDC CONNECTOR

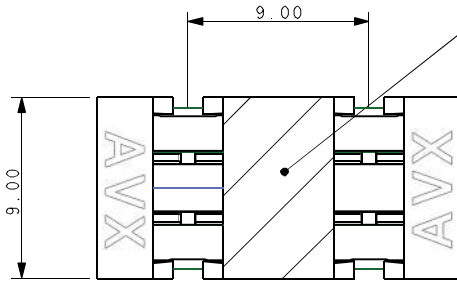

PICK UP AREA 4.75 x 9.00mm MIN

#### NOTES:

1. CONNECTOR FOR IDC WIRE TO BOARD CONNECTION.
2. CONTACT MATERIAL: PHOSPHOR BRONZE. INSULATION MATERIAL: HIGH TEMP NYLON 46, COLOUR REFER TO PAGE 60.
3. CONNECTOR DESIGN TO ACCEPT BETWEEN 14AWG AND 20AWG SOLID AND STRANDED WIRE.
4. ALL DIMENSIONS  $\pm 0.20$  UNLESS TOLLERANCED.
5. FOR FULL PRODUCT SPECIFICATION ON STANDARD CONNECTORS REFER TO SPEC 201-01-109.
6. APPLICATION NTOES 201-01-124.
7. FOR UL PRODUCT CODES UL REFERENCE E320991
8. FOR PCB SPACE RESTRICTED BY ASSEMBLY TOOLING REFER TO PAGE 67

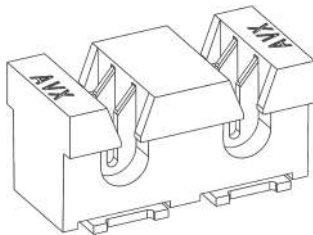
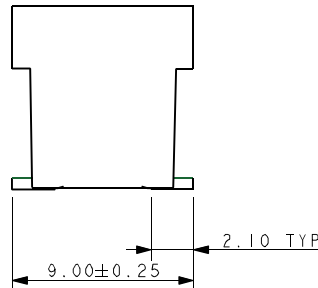
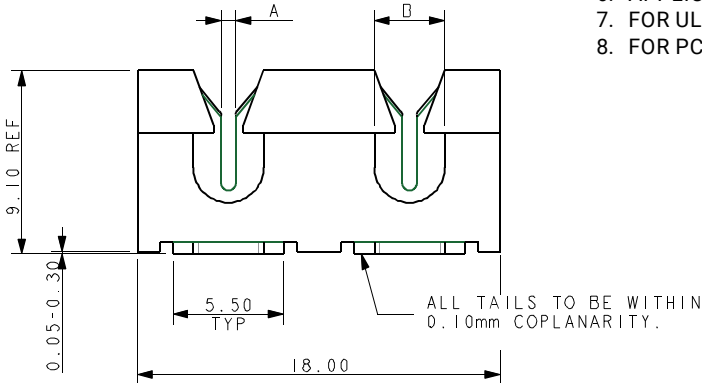

Code	Accepted Wire Gauge	A	Wire Insulation	B
001	14 AWG Solid or Stranded	1.10	Ø4.25 max	4.25
012	16 AWG Solid or Stranded	0.82	Ø3.50 max	3.50
022	18 AWG Solid or Stranded	0.72	Ø3.50 max	3.50
033	20 AWG Solid or Stranded	0.60	Ø2.75 max	2.75

#### SMT PCB LAYOUT PURE TIN PADS

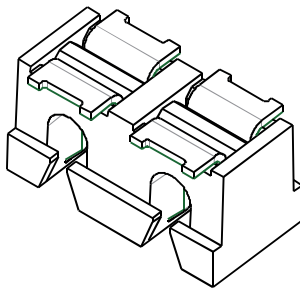
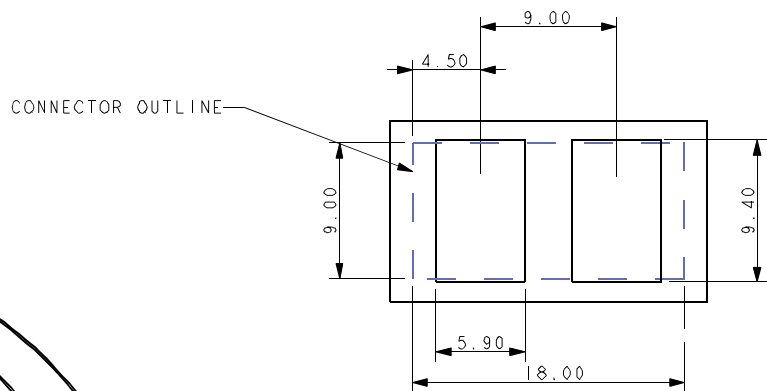

#### PACKING DETAILS

REEL QTY	400
LEADER	500mm
TRAILER	400mm
REEL DIAMETER	330mm

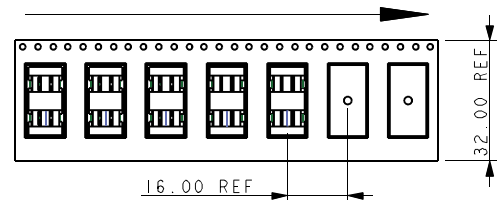
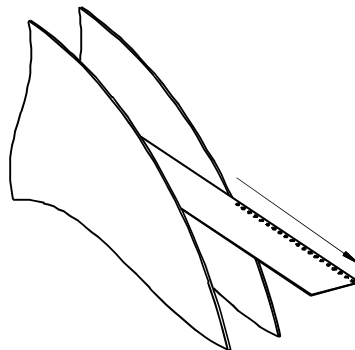

# STANDARD 14-20 AWG: 9177-000

## 3 Position

### 14-20 AWG 3 WAY IDC CONNECTOR

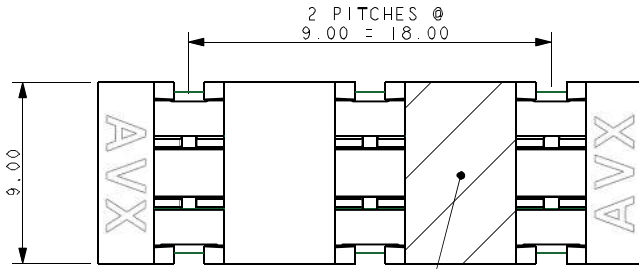

PICK UP AREA 4.75 x 9.00mm MIN

#### NOTES:

- CONNECTOR FOR IDC WIRE TO BOARD CONNECTION.
- CONTACT MATERIAL: PHOSPHOR BRONZE.  
INSULATION MATERIAL: HIGH TEMP NYLON 46, COLOUR REFER TO PAGE 60
- CONNECTOR DESIGNED TO ACCEPT BETWEEN 14AWG AND 20AWG SOLID AND STRANDED WIRE.
- ALL DIMENSIONS  $\pm 0.20$  UNLESS TOLERANCED.
- FOR FULL PRODUCT SPECIFICATION ON STANDARD CONNECTORS REFER TO SPEC 201-01-109.
- APPLICATION NOTES 201-01-124.
- FOR UL PRODUCT CODES UL REFERENCE E320991.
- FOR PCB SPACE RESTRICTED BY ASSEMBLY TOOLING REFER TO PAGE 67

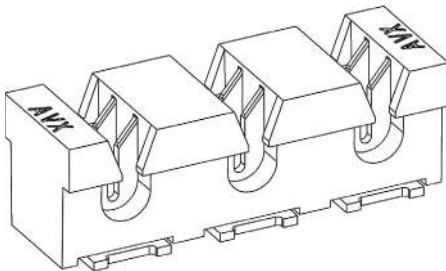
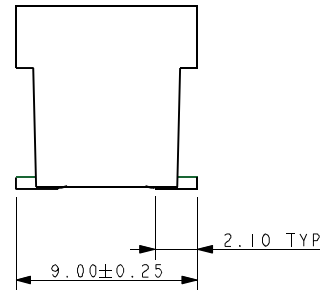
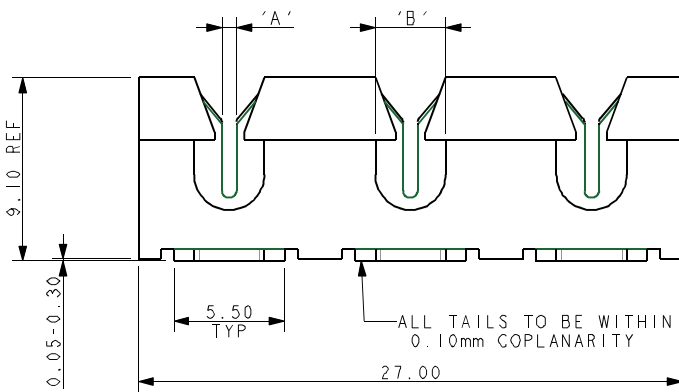

Code	Accepted Wire Gauge	A	Wire Insulation	B
001	14 AWG Solid or Stranded	1.10	Ø 4.25 max	4.25
012	16 AWG Solid or Stranded	0.82	Ø 3.50 max	3.50
022	18 AWG Solid or Stranded	0.72	Ø 3.50 max	3.50
033	20 AWG Solid or Stranded	0.60	Ø 2.75 max	2.75

#### SMT PCB LAYOUT PURE TIN PADS

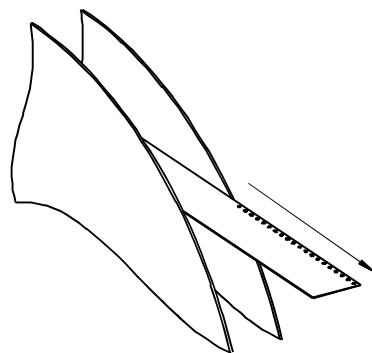
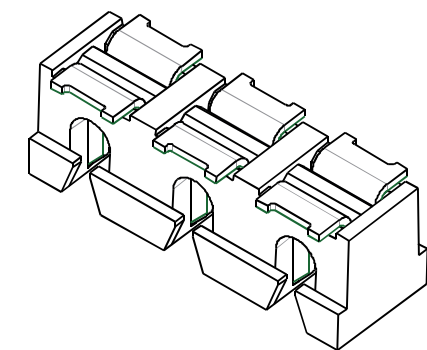
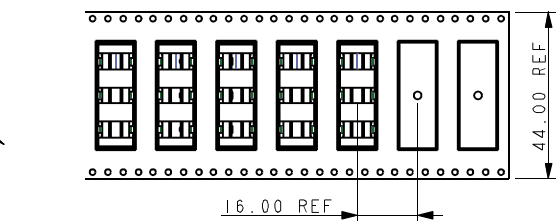
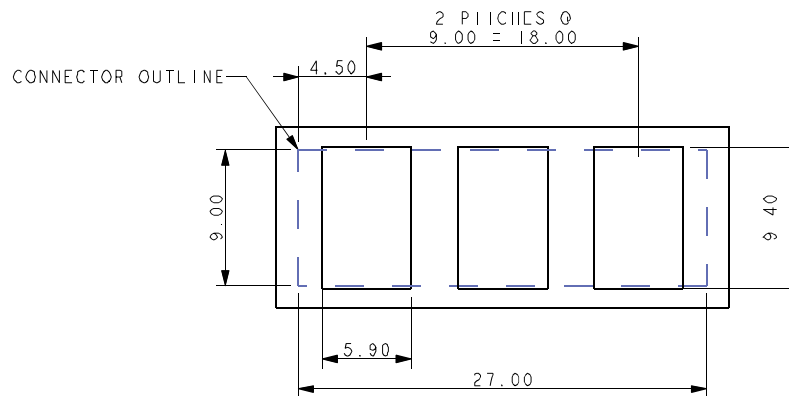

#### PACKING DETAILS

REEL QTY	400
LEADER	500mm
TRAILER	400mm
REEL DIAMETER	330mm

# STANDARD 14-20 AWG: 9177-000

## Accessory Cap - Through Wire

### ACCESSORY CAP – THROUGH WIRE

#### HOW TO ORDER

60 9177 00X

Code	No of Ways
001	1
002	2
003	3

0XX

Code	Wire Insulation Diameter (Note 3)	"A"	"B"
027	2.10mm - 2.75mm	ø 2.75	2.00
035	2.75mm - 3.50mm	ø 3.50	2.65
042	3.50mm - 4.25mm	ø 4.25	3.40

X00

Code	COLOUR
000	Black
100	White

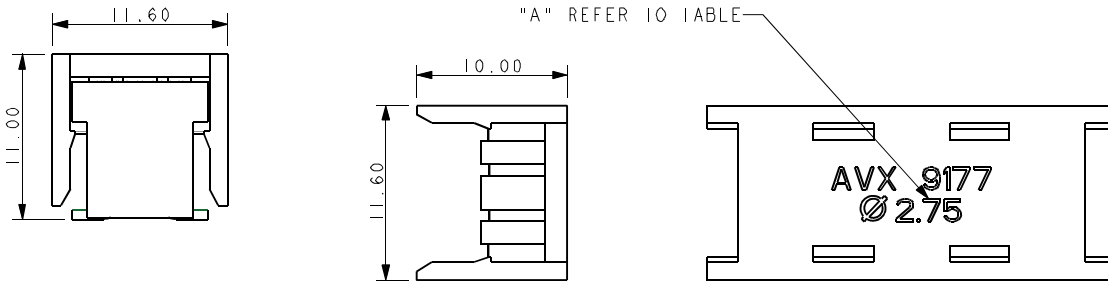

#### ASSEMBLED DIMENSIONS

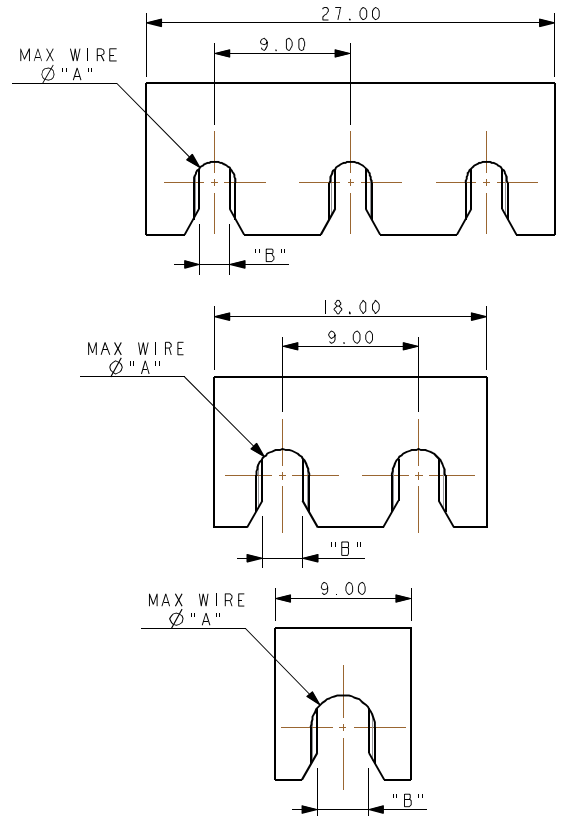
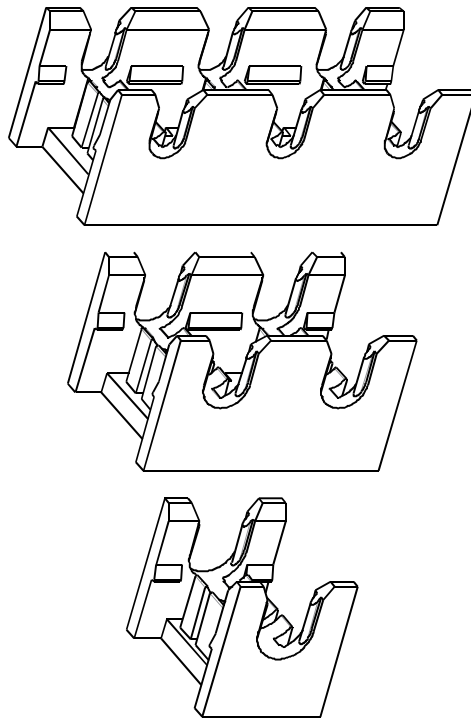

#### NOTES:

- CAP FOR 9177 IDC WIRE TO BOARD CONNECTOR.
- THROUGH WIRE CAP CAN BE USED AT ANY POSITION ALONG WIRE.
- REFERS TO CAP, FOR WIRE MATCH TO CONNECTOR REFER TO TABLE
- MATERIAL: GLASS FILLED NYLON 46, FOR COLOUR REFER TO TABLE
- CAPS DESIGNED TO ACCOMMODATE INSULATION DIAMETERS REFER TO TABLE.
- GENERAL TOLERANCE  $\pm 0.20$ mm.
- PACKED IN BAGS, 400 PIECES PER BAG
- APPLICATION NOTES REFER TO SPECIFICATION 201-01-124

# STANDARD 14-20 AWG: 9177-000

## Accessory Cap - Wire Stop

### ACCESSORY CAP – WIRE STOP

#### HOW TO ORDER

**60**  
Prefix  
60 = Cap

**9177**  
Series

**00X**  
Number of Ways

Code	No of Ways
001	1
002	2
003	3

**OXX**  
Wire Gauge Size

Code	Wire Insulator Diameter (Note 3)	A	B
027	2.10mm-2.75mm	Ø2.75	2.00
035	2.75mm-3.50mm	Ø3.50	2.65
042	3.50mm-4.25mm	Ø4.25	3.40

**X00**  
Insulator Color

Code	Color
099	Black
199	White

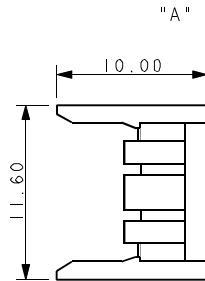
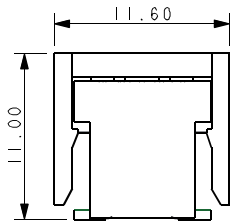

"A" REFER TO TABLE

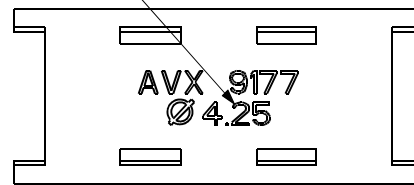

#### ASSEMBLED DIMENSIONS

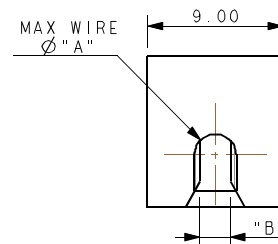
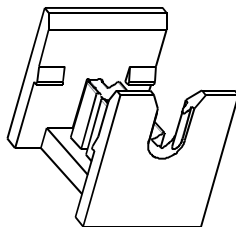
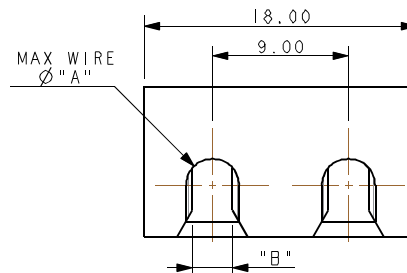
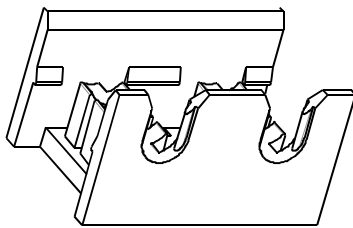
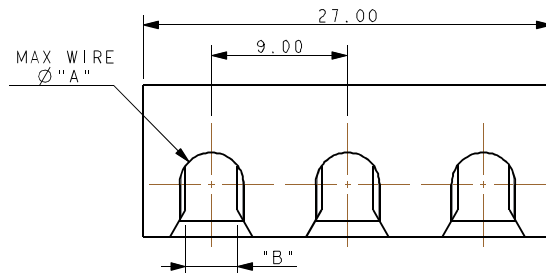
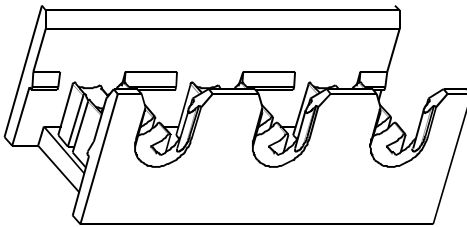

#### NOTES:

- CAP FOR 9177 IDC WIRE TO BOARD CONNECTOR.
- REFERS TO CAP, FOR WIRE MATCH TO CONNECTOR REFER TO TABLE ON PAGE 60.
- MATERIAL: GLASS FILLED NYLON 46. FOR COLOR REFER TO PAGE 60.
- CAPS DESIGNED TO ACCOMMODATE INSULATION DIAMETERS REFER TO PAGE 60.
- GENERAL TOLERANCE  $\pm 0.20\text{MM}$ .
- PACKED IN BAGS, 400 PIECES PER BAG.
- APPLICATION NOTES REFER TO ELCO SPECIFICATION 201-01-124.

# STANDARD 14-20 AWG: 9177-000

## Insertion Tooling

### INSERTION TOOLING – REQUIRES HAND PRESS

1 WAY

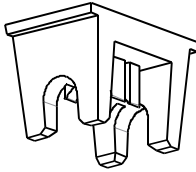

2 WAY

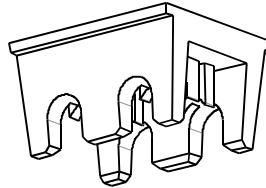

3 WAY

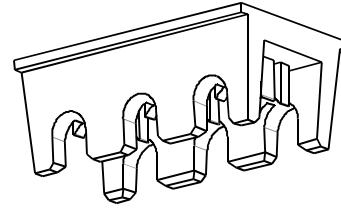

**HIGH PRODUCTION**  
Metal

No. of Ways	Max Insulation Dia (AWG)	Tool Part Number
1	ø 4.25	06-9177-7017-01-001
	ø 3.50	06-9177-7017-02-001
	ø 2.75	06-9177-7017-03-001
2	ø 4.25	06-9177-7017-01-002
	ø 3.50	06-9177-7017-02-002
	ø 2.75	06-9177-7017-03-002
3	ø 4.25	06-9177-7017-01-003
	ø 3.50	06-9177-7017-02-003
	ø 2.75	06-9177-7017-03-003

**MEDIUM PRODUCTION**  
Plastic

No. of Ways	Max Insulation Dia (AWG)	Tool Part Number
1	ø 4.25	06-9177-7016-01-001
	ø 3.50	06-9177-7016-02-001
	ø 2.75	06-9177-7016-03-001
2	ø 4.25	06-9177-7016-01-002
	ø 3.50	06-9177-7016-02-002
	ø 2.75	06-9177-7016-03-002
3	ø 4.25	06-9177-7016-01-003
	ø 3.50	06-9177-7016-02-003
	ø 2.75	06-9177-7016-03-003

The assembly tooling restricts the available space/component heights on the PCB. For details see below.

NOTES:

1. ALL DIMENSIONS FOR REFERENCE DIMENSIONS.
2. MAXIMUM COMPONENT HEIGHT 0.80MM IN THIS AREA.
3. MAXIMUM COMPONENT HEIGHT 11.00 MM IN THIS AREA.
4. THE SAME RESTRICTIONS APPLY TO ALL WIRE INSULATION DIAMETERS.
5. GENERAL TOLERANCE ±0.20MM.

### INSERTION TOOLING – PCB RESTRICTED AREAS FOR ASSEMBLY TOOLING

1 WAY

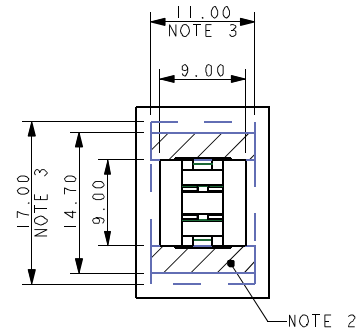
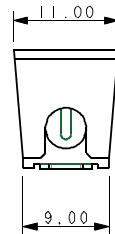
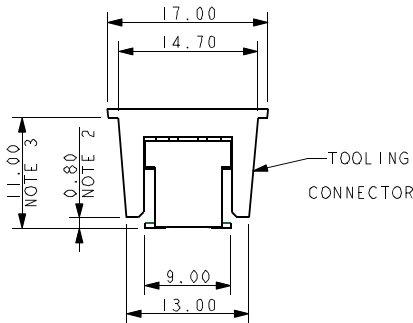

2 WAY

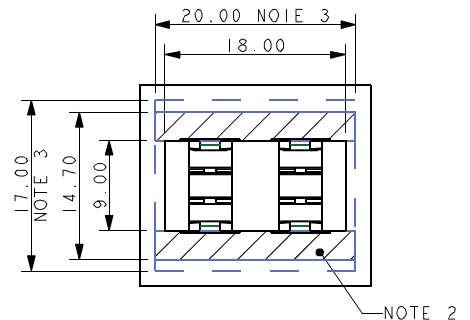
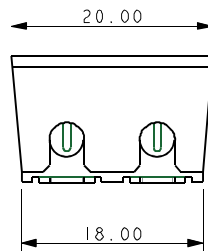
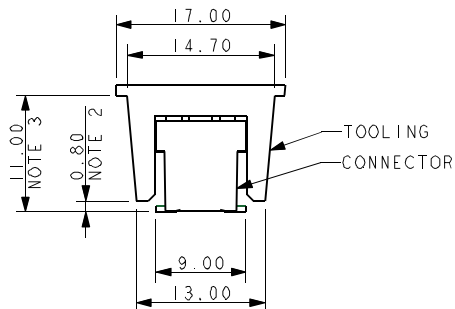

3 WAY

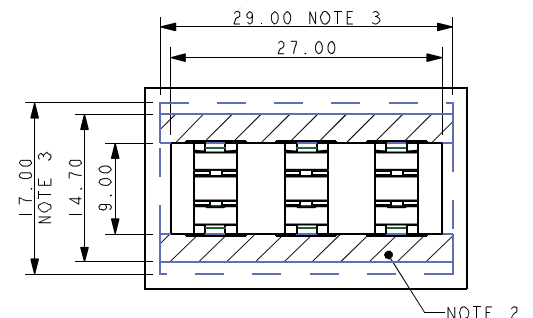
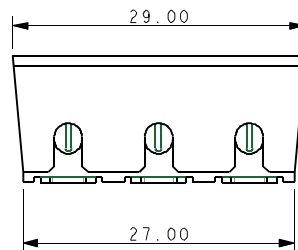
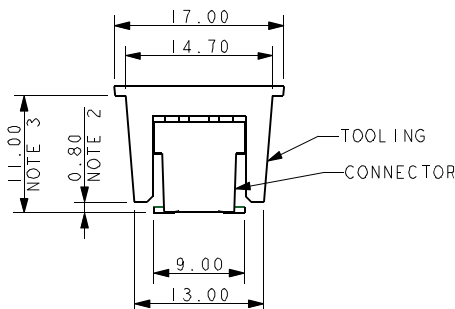



# STANDARD 14-20 AWG: 9177-000

## Assembled Connector

### STANDARD CONNECTOR

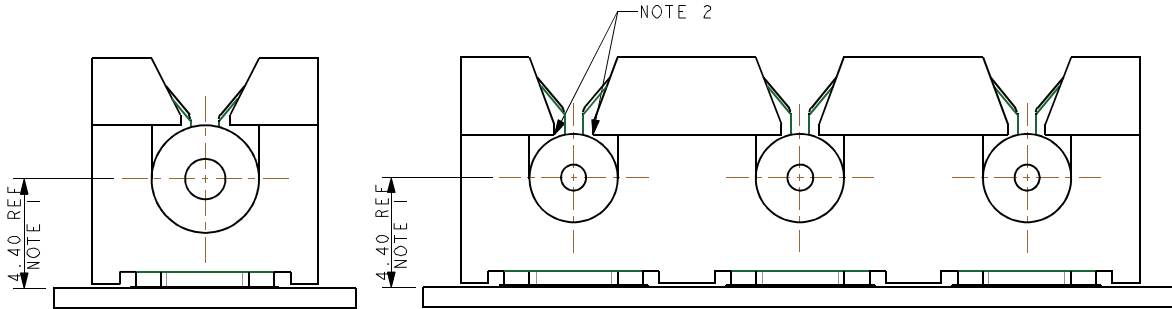

### CONNECTOR WITH CAP

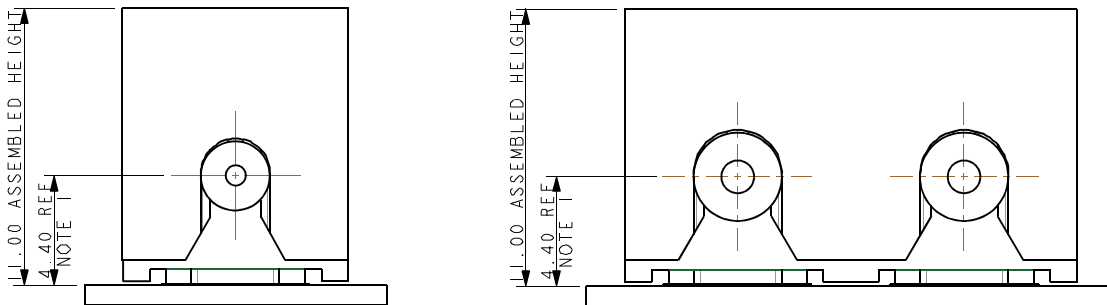

#### NOTES:

1. ASSEMBLED HEIGHTS INCLUDE 0.10mm ALLOWANCE FOR PAD AND SOLDER THICKNESS, NO ALLOWANCE HAS BEEN MADE FOR ANY SOLDER RESIST OR OTHER FEATURES.
2. WHEN THE WIRE IS ASSEMBLED THE INSULATION SHOULD BE TRAPPED BY THESE EDGES.