

Notes:

1. 10 sprocket hole pitch cumulative tolerance ± 0.2
2. Camber not to exceed 1mm in 100mm.
3. Material: Polystyrene.
4. Pocket position relative to sprocket hole measured as true position of pocket, not pocked hole.
5. All dimensions meet EIA-481-B requirements.
6. Quantity: 3000 PCS/REEL

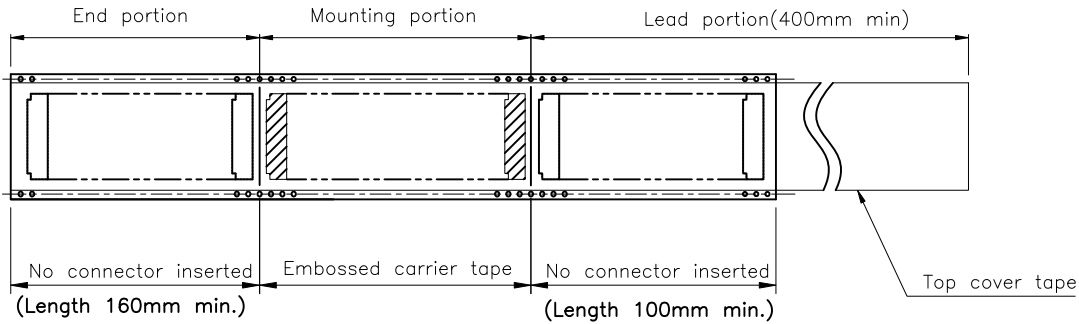

Circuits	Dimension					Packing (Reel/Carton)
	E	F	W1	W2	W3	
4-11	16.0(.630)	7.50(.295)	16.5(.650)	22.5(.885)	16.5(.650)	11
12-29	24.0(.945)	11.50(.453)	24.5(.965)	30.5(1.200)	24.5(.965)	9
30	32.0(1.260)	14.20(.559)	32.5(1.280)	38.5(1.516)	32.5(1.280)	7

TAPE RUNNING DIRECTION

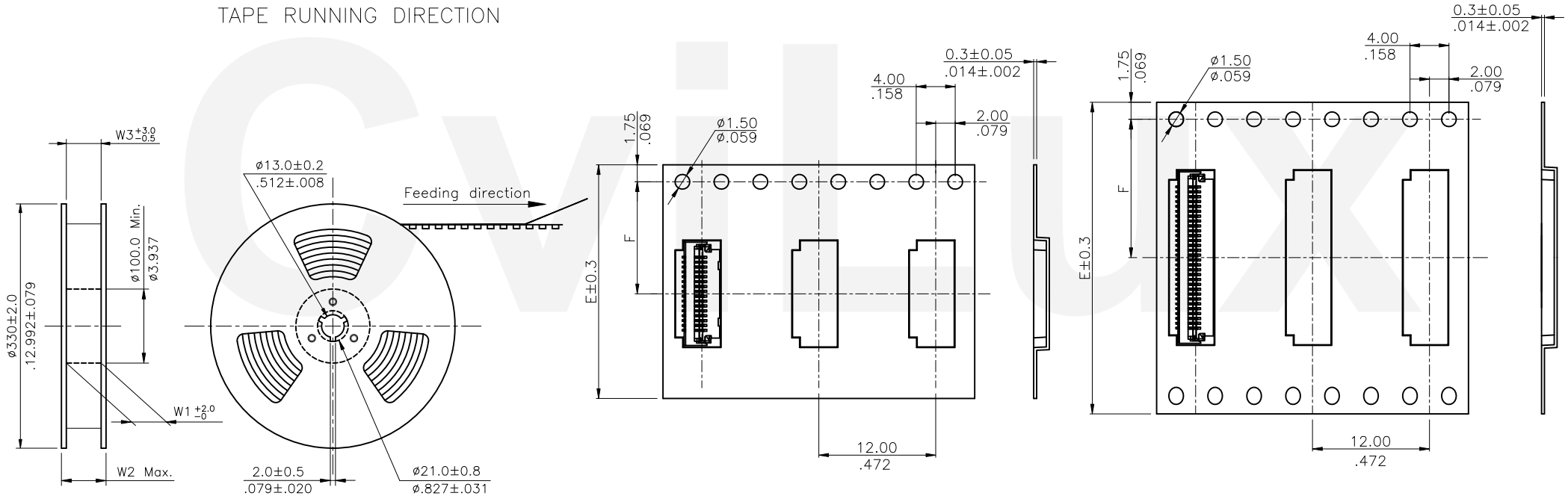

WIDTH : 16,24 mm Carrier
(SCALE 1:4)

WIDTH : 32 mm Carrier
(SCALE 1:4)

RoHS Compliant

4					DATE	UNIT: mm / inch	TITLE: 0.50mm(.020") ZIF FFC/FPC ONE-TOUCH CONNECTOR (Enhanced version)	 瀚基股份有限公司 CviLux Corporation			
3					DATE	TOLERANCE UNLESS OTHERWISE SPECIFIED	MATERIAL:				DRAWING NO.
2					DATE	.X \pm 0.15/.006	.X' \pm	SCALE	10 / 1	SHEET	3 OF 3
1	Sandy	10/15-20	ECNT120249		DATE	.XX \pm 0.10/.004	.X' \pm 1'				
SYM	NAME	DATE	REVISIONS		DATE	.XXX \pm	.XX' \pm				

CIVILUX CORP
2020.10.23
ISSUED

DRAWN BY: Sandy
ENGINEER: Sun
CHECKED BY: Eisley
APPROVED BY: Eisley

10/16-20'
10/16-20'
10/19-20'
10/19-20'

FINISH: