

PART NUMBER	REVISION	DESCRIPTION	FEED TYPE
2151428-1	F	FINE CRIMP HEIGHT ADJUST	MECHANICAL
2151428-2	F	FINE CRIMP HEIGHT ADJUST	PNEUMATIC
5-2151428-1	F	SEAL STRIPPER CRIMPER TERMINATING UNIT	MECHANICAL
5-2151428-2	F	SEAL STRIPPER CRIMPER TERMINATING UNIT	PNEUMATIC
7-2151428-1	F	MECHANICAL AND CRIMP TOOLING KIT	MECHANICAL
7-2151428-2	F	PNEUMATIC AND CRIMP TOOLING KIT	PNEUMATIC
7-2151428-7	A	CRIMP TOOLING KIT	-

ATLANTIC VERSION TERMINATOR INTERFACE ADAPTER

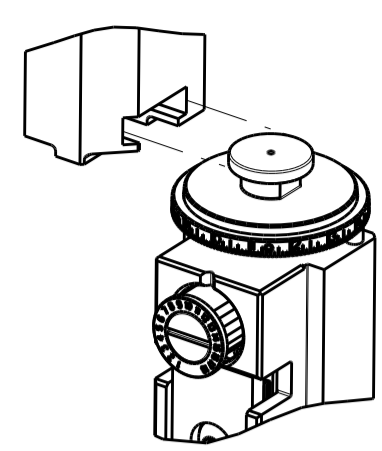

APPLICATOR DATA		
CRIMP	SIZE	TYPE
WIRE	1.07 mm [.042]	F
INSUL	1.40 mm [.055]	O

APPLICATOR INSTRUCTIONS
408-35042

TERMINAL DATA: TE TERMINAL		TE CRIMP SPECIFICATION	
TERMINAL NAME: PIN CONTACT SIZE 20 DF 24-28 WAG			
WIRE STRIP LENGTH		INSULATION DIAMETER RANGE	
.083-.103 IN [2.11-2.62 mm]		Ø.030-.040 IN [0.76-1.02 mm]	
TERMINAL APPLICATION SPECIFICATION	114-10000		
TERMINALS APPLIED			
TE TERMINAL	TE TERMINAL	TE TERMINAL	TE TERMINAL
66507-2	66507-3	66507-4	2-66507-8
6-66507-4	166054-1	215862-1	1658540-1
1658540-3	1658540-4	1658540-7	1658538-2
1658538-3	1658538-5	66505-1	66505-2
66505-3	66505-4	66505-8	66505-9
1-66505-0	1-66505-3	2-66505-7	6-66505-9
7-66505-1	166052-1	166052-8	745502-2

WIRE SIZE	CRIMP HEIGHT mm [INCH]	CRIMP HEIGHT REFERENCE SETTING
24 AWG	0.81+/-0.03 [.032+/- .001]	7.9
26 AWG	0.76+/-0.03 [.030+/- .001]	8.4
28 AWG	0.66+/-0.03 [.026+/- .001]	9.7

- 1. RECOMMENDED SPARE PARTS
- 2. REFER TO SUPPLIED INSTRUCTION SHEET FOR CLEANING, LUBRICATION AND STORAGE OF APPLICATOR.
- 3. APPLY PART NUMBER 1-23419-5 LOCTITE TO THREADS OF ITEMS 180. APPLY PART NUMBER 2-23419-6 LOCTITE TO THREADS OF ITEM 242.
- 4. CRIMP HEIGHT REFERENCE SETTING WAS THE SETTING USED WHEN THE APPLICATOR WAS QUALIFIED AT THE FACTORY. ADJUSTMENT MAY BE NECESSARY WHEN RUNNING APPLICATOR IN THE FIELD.
- 5. TERMINAL LUBRICANT IS RECOMMENDED.
- 6. UNLESS SPECIFIED OTHERWISE TORQUE VALUES SHALL BE USED PER DOCUMENT, 101-35000.

***WARNING**
 ON INSTALLATION, SET WIRE DISC TO CRIMP HEIGHT REFERENCE SETTING FOR LARGEST WIRE SIZE. CRIMP HEIGHT REFERENCE SETTINGS GREATER THAN THE VALUE SHOWN MAY CAUSE DAMAGE TO THE CRIMP TOOLING, REFER TO THE INSTRUCTION SHEET FOR PROPER SETUP AND ADJUSTMENTS.

ATLANTIC VERSION
 Shown on sheets 1 of 4 & 2 of 4
 (Pacific version shown on sheets 3 of 4 & 4 of 4)

LOC	DIST	REVISIONS			
A	66	REV	DATE	BY	CHKD
		C1	ECR-18-013947	04SEP2018	FL KZ
		D	ECR-18-019110	07DEC2018	KH LZ
		E	ECR-19-003778	08MAR2019	RK CT
		F	ECR-19-011566	23JUL2019	FZ RK

-	-	-	1	1	-	-	1803515-3	RAM ASSEMBLY, SF ATLANTIC	293
-	-	-	1	1	-	-	2-1803583-1	APPLICATOR BASIC ASSEMBLY, SF	292
-	1	-	1	-	1	-	2119640-1	PUSH ROD, AIR FEED	250
-	1	-	1	-	1	-	1803259-1	BUSHING, FLANGED	249
-	1	-	1	-	1	-	2119641-1	FEED CAM, AIR FEED	248
-	1	1	1	1	1	1	2119082-1	CAM, SNAIL, INSULATION ADJUSTMENT	244
-	1	1	1	1	1	1	2079764-1	WASHER, WAVE SPRING, CREST-TO-CREST	243
-	1	1	1	1	1	1	2119083-1	RETAINER, INSULATION DIAL	242
-	1	1	1	1	1	1	7-18023-7	SCR, SKT HD CAP M3 X 4.0	241
-	-	1	-	1	-	1	2119580-1	MECHANICAL FEED ASSEMBLY	239
-	1	-	1	-	1	-	2063440-1	AIR FEED MODULE	238
-	-	-	1	1	-	-	4-1722335-3	STRIPPER, SIDE FEED	182
-	-	-	1	1	-	-	1-5018030-0	NUT, HEX, REG, RoHS, M3.5	181
-	-	-	1	1	-	-	1-1752354-4	STANDOFF, HOLD-DOWN	180
-	-	-	1	1	-	-	993111-1	PIN, SLOTTED SPRING 3.0 X 20.0	177
-	-	-	1	1	-	-	5-22280-0	SPRING, COMPRESSION	176
-	-	-	1	1	-	-	1752353-3	GUIDE PIN, HOLDDOWN	175
-	-	-	1	1	-	-	1901680-2	GUIDE PIN, HOLDDOWN	174
-	2	-	2	-	2	-	21045-3	RING, RETAIN, EXTERN, 3/16 CRESCENT	172
-	REF	REF	REF	REF	REF	REF	994970-2	COUNTER, MAGNETIC	164
-	1	-	1	-	1	-	240638-1	SPRING, FEED FINGER	163
-	1	-	1	-	1	-	3-23627-7	PIN, RETAIN, GRVD, 3/16 X .854	137
-	1	-	1	-	1	-	2119799-1	HOLDER, FEED FINGER, AF	136
-	1	1	1	1	1	1	2119955-1	ASSY, LUBRICATOR, SIDE FEED	113
-	1	1	1	1	1	1	2844908-1	SCREW, LOCKING	99
-	1	1	1	1	1	1	2844907-1	POST, LOCKING	98
-	1	1	1	1	1	1	455888-5	SPACER, CRIMPER	82
-	1	1	1	1	1	1	1803607-1	DOCUMENTATION PACKAGE	71
-	1	1	1	1	1	1	2119740-1	TAG, IDENTIFICATION	67
-	2	2	2	2	2	2	2168078-1	SCREW, DRIVE, RH, RoHS, 2 x .188	66
-	1	1	1	1	1	1	2168083-2	SCR, SKT HD CAP, RoHS, M4 X 8.0	60
-	1	1	1	1	1	1	5-18022-5	SCR, HEX HD CAP, M4 X 6.0	59
-	1	1	1	1	1	1	1338685-1	PAWL, FEED	56
-	4	4	4	4	4	4	2168083-3	SCR, SKT HD CAP, RoHS, M4 X 12.0	54
-	2	2	2	2	2	2	2168083-3	SCR, SKT HD CAP, RoHS, M4 X 12.0	53
-	1	1	1	1	1	1	18030-1	NUT, HEX, REG M3	52
-	1	1	1	1	1	1	811242-6	BUMPER, HOLD DOWN	51
-	1	1	1	1	1	1	690753-2	SPACER, TONKER	50
-	1	2	1	2	1	2	18023-9	SCR, SKT HD CAP M4 X 6.0	49
-	-	1	-	1	-	1	2119652-1	FEED CAM, PRE FEED	48
-	-	1	-	1	-	1	2119653-1	FEED CAM, POST FEED	47
-	1	1	-	-	1	1	1803583-9	APPLICATOR BASIC ASSEMBLY, SF	46
-	1	1	-	-	1	1	1803515-1	RAM ASSEMBLY, SF ATLANTIC	44
-	1	1	1	1	1	1	1803602-1	SCR, BHSC, RoHS (M8 X 25)	41
-	1	1	1	1	1	1	3-1752356-3	SUPPORT, TERMINAL	34
-	2	2	2	2	2	2	2079383-5	SCR, BHSC, RoHS (M4 X 20)	33
-	2	2	2	2	2	2	2-2844962-3	SPACER, CYLINDRICAL, STRIP GUIDE	30
-	1	1	1	1	1	1	2844992-1	ASSEMBLY, STRIP GUIDE	29
-	1	1	1	1	1	1	455888-3	SPACER, CRIMPER	28
-	1	1	1	1	1	1	1320928-2	STRIP GUIDE	24
-	1	1	-	-	1	1	2168083-2	SCR, SKT HD CAP, RoHS, M4 X 8.0	21
-	2	2	1	1	2	2	1-18028-2	WASHER, FLAT, REG M4	20
-	1	1	-	-	1	1	2119533-1	STRIPPER, SIDE FEED	19
-	1	1	1	1	1	1	2119806-1	INSERT, SHEAR	13
-	1	1	1	1	1	1	3-22280-3	SPRING, COMPRESSION	12
-	1	1	1	1	1	1	1-356885-4	STOP, SHEAR	11
-	1	1	1	1	1	1	2119805-1	SHEAR HOLDER, FRONT	10
-	1	1	1	1	1	1	1803095-1	FLOATING SHEAR, FRONT	9
1	2	2	1	1	1	1	1338689-2	ANVIL, COMBINATION .042	8
-	1	1	1	1	1	1	1-240641-7	SPACER	7
-	-	-	-	-	-	-	-	-	6
-	1	1	1	1	1	1	2119757-8	DEPRESSOR, SHEAR	5
-	1	1	1	1	1	1	2-238011-3	BLOCK, CRIMPER SPACER	4
1	2	2	1	1	1	1	1803019-2	CRIMPER, INSULATION O	3
-	1	1	1	1	1	1	455888-2	SPACER, CRIMPER	2
1	2	2	1	1	1	1	456401-5	CRIMPER, WIRE .042 F PREMIUM	1

ITEM NO	PART NO	DESCRIPTION
-77	-72	-71
-52	-51	-2
-1		

DATE: 26MAR2012	CHKD: C. CHEN	DATE: 26MAR2012	NAME: S. XI
DATE: 26MAR2012	CHKD: J. CRUZ	DATE: 26MAR2012	NAME: J. CRUZ
DATE: 26MAR2012	CHKD: J. CRUZ	DATE: 26MAR2012	NAME: J. CRUZ

TE Connectivity	Harrisburg, PA 17105-3608
Ocean Side Feed Applicator	
SIZE: A1	CAGE CODE: 00779
DRAWING NO: 2151428	SCALE: 1:2
SHEET: 1	OF: 4
REV: F	

LOC	DIST	REV	DATE	BY	APP'D
A	66				

FEED TYPE MECHANICAL

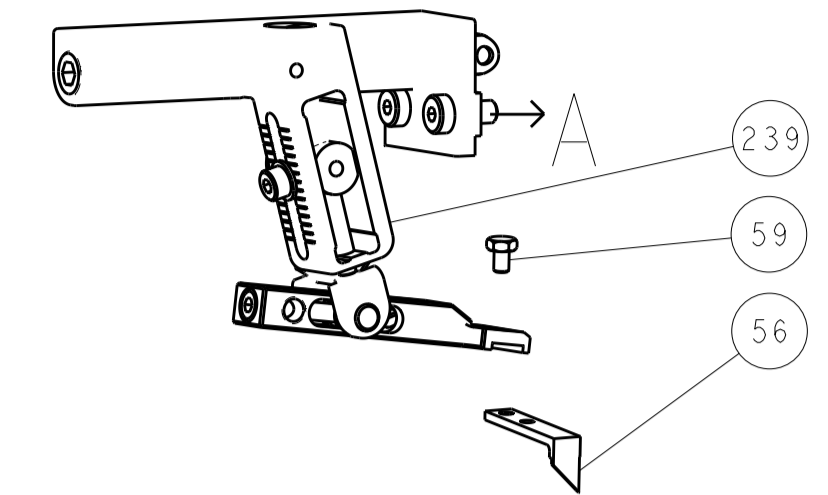

PNEUMATIC

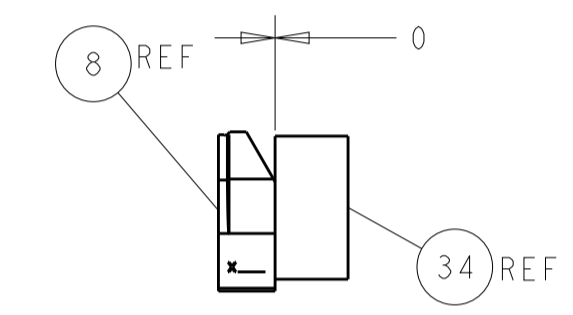
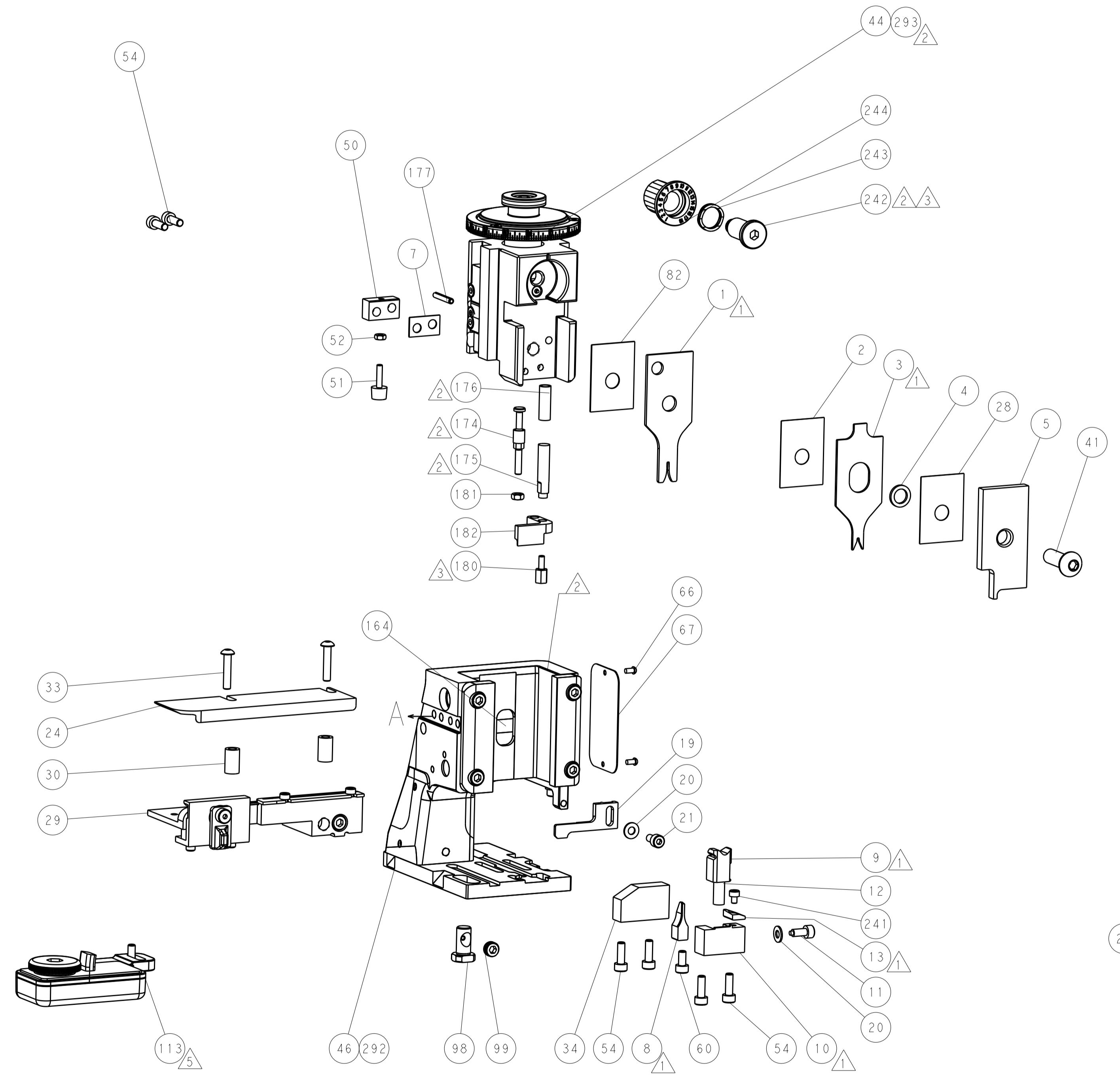
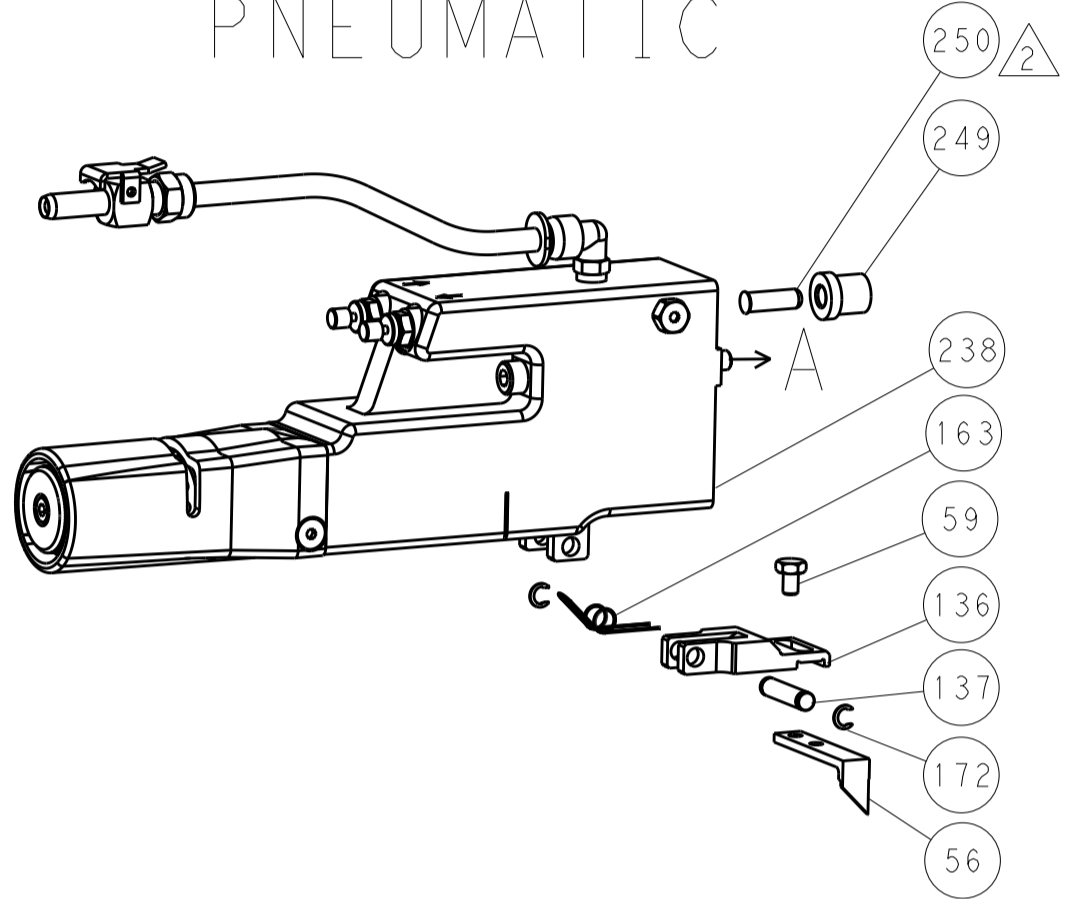

TERMINAL SUPPORT LOCATION

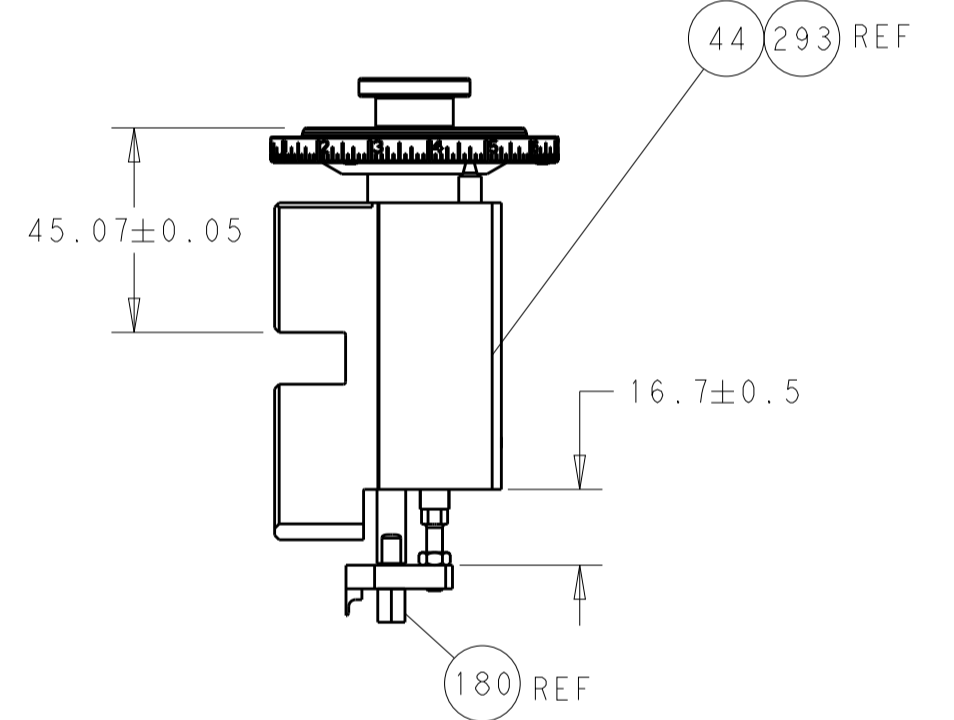

RAM SET-UP

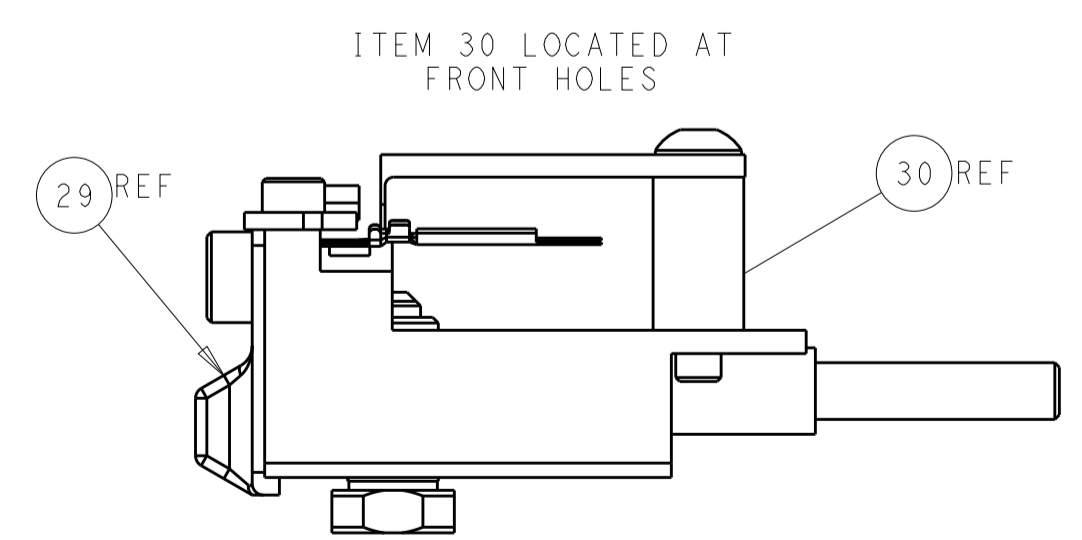

ITEM 30 LOCATED AT FRONT HOLES

CAM POSITIONS

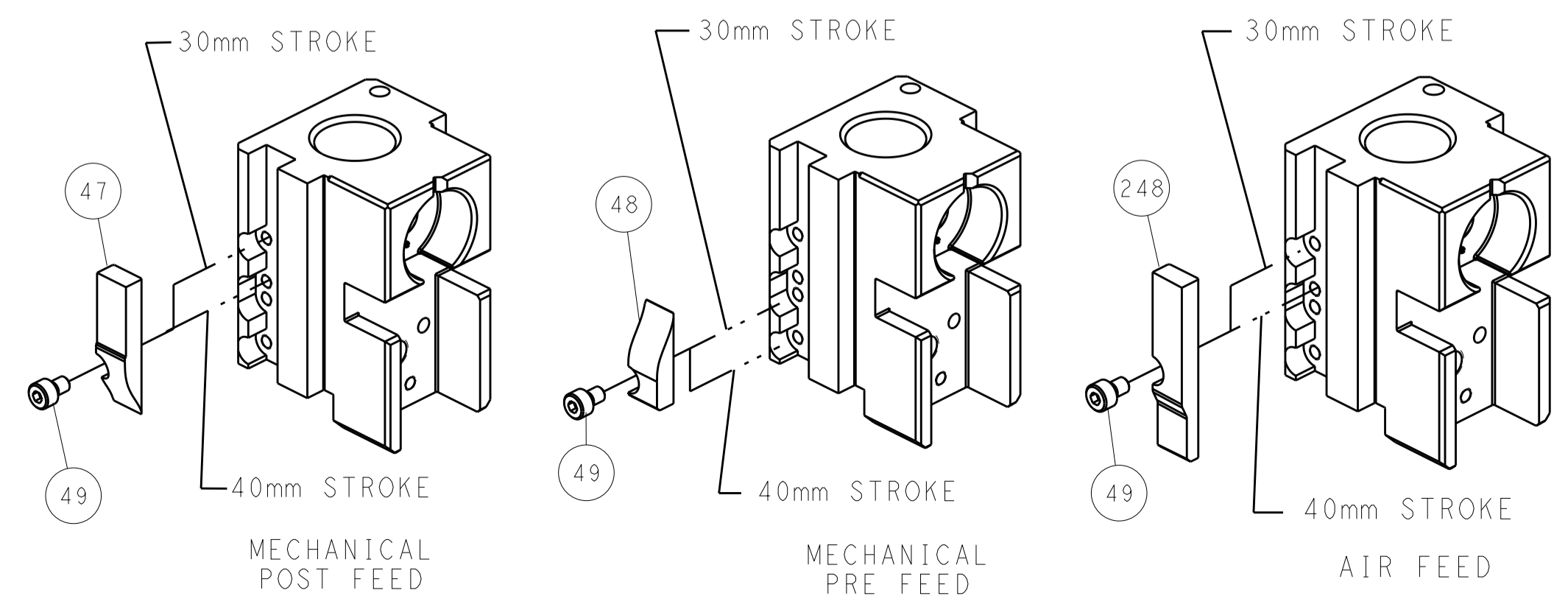

ATLANTIC VERSION
 Shown on sheets 1 of 4 & 2 of 4
 (Pacific version shown on sheets 3 of 4 & 4 of 4)

DIMENSIONS: mm 		TOLERANCES UNLESS OTHERWISE SPECIFIED: 0 PLC ± 1 PLC ± 2 PLC ± 3 PLC ± 4 PLC ± ANGLES ±		DWN: C. CHEN 26MAR2012 CHK: S. XI 26MAR2012 APVD: J. CRUZ 26MAR2012 PRODUCT SPEC APPLICATION SPEC WEIGHT SCALE: 1:2		NAME: Ocean Side Feed Applicator SIZE: A1 CAGE CODE: 00779 DRAWING NO: 2151428 SHEET: 2 of 4 REV: F	
MATERIAL:				FINISH:		RESTRICTED TO:	

PART NUMBER	REVISION	DESCRIPTION	FEED TYPE
2-2151428-1	F	FINE CRIMP HEIGHT ADJUST	MECHANICAL
2-2151428-2	F	FINE CRIMP HEIGHT ADJUST	PNEUMATIC
7-2151428-7	A	CRIMP TOOLING KIT	-

PACIFIC VERSION TERMINATOR
 INTERFACE ADAPTER

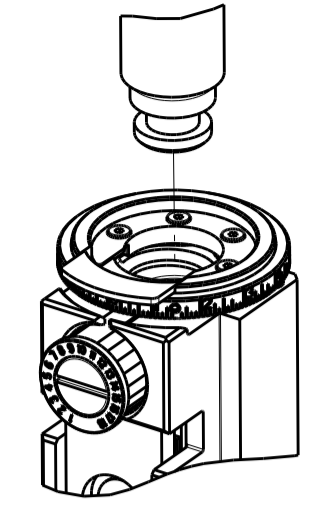

APPLICATOR DATA		
CRIMP	SIZE	TYPE
WIRE	1.07 mm [.042]	F
INSUL	1.40 mm [.055]	O

APPLICATOR INSTRUCTIONS
 408-35042

TERMINAL DATA: TE TERMINAL		TE CRIMP SPECIFICATION	
TERMINAL NAME: PIN CONTACT SIZE 20 DF 24-28 WAG			
WIRE STRIP LENGTH		INSULATION DIAMETER RANGE	
.083-.103 IN [2.11-2.62 mm]		∅.030-.040 IN [0.76-1.02 mm]	
TERMINAL APPLICATION SPECIFICATION	114-10000		
TERMINALS APPLIED			
TE TERMINAL	TE TERMINAL	TE TERMINAL	TE TERMINAL
66507-2	66507-3	66507-4	2-66507-8
6-66507-4	166054-1	215862-1	1658540-1
1658540-3	1658540-4	1658540-7	1658538-2
1658538-3	1658538-5	66505-1	66505-2
66505-3	66505-4	66505-8	66505-9
1-66505-0	1-66505-3	2-66505-7	6-66505-9
7-66505-1	166052-1	166052-8	745502-2

WIRE SIZE	CRIMP HEIGHT mm [INCH]	CRIMP HEIGHT REFERENCE SETTING
24 AWG	0.81+/-0.03 [.032+/-0.001]	7.9
26 AWG	0.76+/-0.03 [.030+/-0.001]	8.4
28 AWG	0.66+/-0.03 [.026+/-0.001]	9.7

- RECOMMENDED SPARE PARTS
 - REFER TO SUPPLIED INSTRUCTION SHEET FOR CLEANING, LUBRICATION AND STORAGE OF APPLICATOR.
 - APPLY PART NUMBER 2-23419-6 LOCTITE TO THREADS OF ITEM 242.
 - CRIMP HEIGHT REFERENCE SETTING WAS THE SETTING USED WHEN THE APPLICATOR WAS QUALIFIED AT THE FACTORY. ADJUSTMENT MAY BE NECESSARY WHEN RUNNING APPLICATOR IN THE FIELD.
 - TERMINAL LUBRICANT IS RECOMMENDED.
6. UNLESS SPECIFIED OTHERWISE TORQUE VALUES SHALL BE USED PER DOCUMENT, 101-35000.

***WARNING**
 ON INSTALLATION, SET WIRE DISC TO CRIMP HEIGHT REFERENCE SETTING FOR LARGEST WIRE SIZE. CRIMP HEIGHT REFERENCE SETTINGS GREATER THAN THE VALUE SHOWN MAY CAUSE DAMAGE TO THE CRIMP TOOLING. REFER TO THE INSTRUCTION SHEET FOR PROPER SETUP AND ADJUSTMENTS.

PACIFIC VERSION
 Shown on sheets 3 of 4 & 4 of 4
 (Atlantic version shown on sheets 1 of 4 & 2 of 4)

LOC	DIST	REV	DATE	BY	APPV
A	66				

REV	DATE	BY	APPV	DESCRIPTION	ITEM NO	
-	1	-		2119640-1	PUSH ROD, AIR FEED	250
-	1	-		1803259-1	BUSHING, FLANGED	249
-	1	1		2119082-1	CAM, SNAIL, INSULATION ADJUSTMENT	244
-	1	1		2079764-1	WASHER, WAVE SPRING, CREST-TO-CREST	243
-	1	1		2119083-1	RETAINER, INSULATION DIAL	242
-	1	1		7-18023-7	SCR, SKT HD CAP M3 X 4.0	241
-	-	1		2119580-1	MECHANICAL FEED ASSEMBLY	239
-	1	-		2063440-1	AIR FEED MODULE	238
-	2	-		21045-3	RING, RETAIN, EXTERN, 3/16 CRESCENT	172
-	REF	REF		994970-2	COUNTER, MAGNETIC	164
-	1	-		240638-1	SPRING, FEED FINGER	163
-	1	-		2119641-2	FEED CAM, AIR FEED	151
-	1	1		2168083-8	SCR, SKT HD CAP, RoHS, M4 X 16	144
-	4	4		2168083-9	SCR, SKT HD CAP, RoHS, M4 X 20	143
-	-	1		2119653-2	FEED CAM, POST FEED	142
-	1	1		1-1803583-0	APPLICATOR BASIC ASSEMBLY, SF	141
-	1	1		1803516-1	RAM ASSEMBLY, SF PACIFIC	140
-	1	-		3-23627-7	PIN, RETAIN, GRVD, 3/16 X .854	137
-	1	-		2119799-1	HOLDER, FEED FINGER, AF	136
-	1	1		2119955-1	ASSY, LUBRICATOR, SIDE FEED	113
-	1	1		2844908-1	SCREW, LOCKING	99
-	1	1		2844907-1	POST, LOCKING	98
-	1	1		455888-5	SPACER, CRIMPER	82
-	1	1		1803607-1	DOCUMENTATION PACKAGE	71
-	1	1		2119740-1	TAG, IDENTIFICATION	67
-	2	2		2168078-1	SCREW, DRIVE, RH, RoHS, 2 x .188	66
-	1	1		5-18022-5	SCR, HEX HD CAP, M4 X 6.0	59
-	1	1		1338685-1	PAWL, FEED	56
-	2	2		2168083-3	SCR, SKT HD CAP, RoHS, M4 X 12.0	53
-	1	1		18030-1	NUT, HEX, REG M3	52
-	1	1		811242-6	BUMPER, HOLD DOWN	51
-	1	1		690753-2	SPACER, TONKER	50
-	1	2		18023-9	SCR, SKT HD CAP M4 X 6.0	49
-	-	1		2119652-1	FEED CAM, PRE FEED	48
-	1	1		1803602-1	SCR, BHSC, RoHS (M8 X 25)	41
-	1	1		3-1752356-3	SUPPORT, TERMINAL	34
-	2	2		2079383-5	SCR, BHSC, RoHS (M4 X 20)	33
-	2	2		2-2844962-3	SPACER, CYLINDRICAL, STRIP GUIDE	30
-	1	1		2844992-1	ASSEMBLY, STRIP GUIDE	29
-	1	1		455888-3	SPACER, CRIMPER	28
-	1	1		1320928-2	STRIP GUIDE	24
-	1	1		2168083-2	SCR, SKT HD CAP, RoHS, M4 X 8.0	21
-	2	2		1-18028-2	WASHER, FLAT, REG M4	20
-	1	1		2119533-1	STRIPPER, SIDE FEED	19
-	1	1		2119806-1	INSERT, SHEAR	13
-	1	1		3-22280-3	SPRING, COMPRESSION	12
-	1	1		1-356885-4	STOP, SHEAR	11
-	1	1		2119805-1	SHEAR HOLDER, FRONT	10
-	1	1		1803095-1	FLOATING SHEAR, FRONT	9
-	1	1		1338689-2	ANVIL, COMBINATION .042	8
-	1	1		1-240641-7	SPACER	7
-	-	-		-	-	6
-	1	1		2119757-8	DEPRESSOR, SHEAR	5
-	1	1		2-238011-3	BLOCK, CRIMPER SPACER	4
-	1	1		1803019-2	CRIMPER, INSULATION O	3
-	1	1		455888-2	SPACER, CRIMPER	2
-	1	1		456401-5	CRIMPER, WIRE .042 F PREMIUM	1

DIMENSIONS: mm 		TOLERANCES UNLESS OTHERWISE SPECIFIED: 0 PLC ± 1 PLC ± 2 PLC ± 3 PLC ± 4 PLC ± ANGLES ± FINISH		DWN: C. CHEN 26MAR2012 CHK: S. XI 26MAR2012 APPV: J. CRUZ 26MAR2012		NAME: Ocean Side Feed Applicator SIZE: A1 CAGE CODE: 00779 DRAWING NO: 2151428 SCALE: 1:2 SHEET: 3 OF 4 REV: F	
-----------------------	--	---	--	---	--	--	--

LOC	DIST	REVISIONS				
A	66	P. LTM	DESCRIPTION	DATE	DWN	APVD
-	-	-	SEE SHEET 1	-	-	-

FEED TYPE MECHANICAL

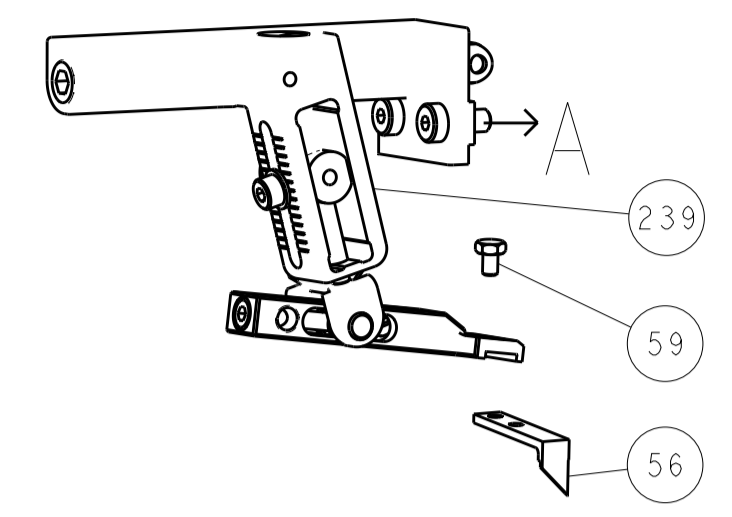

PNEUMATIC

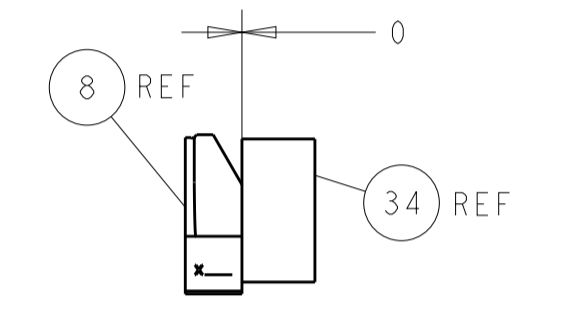
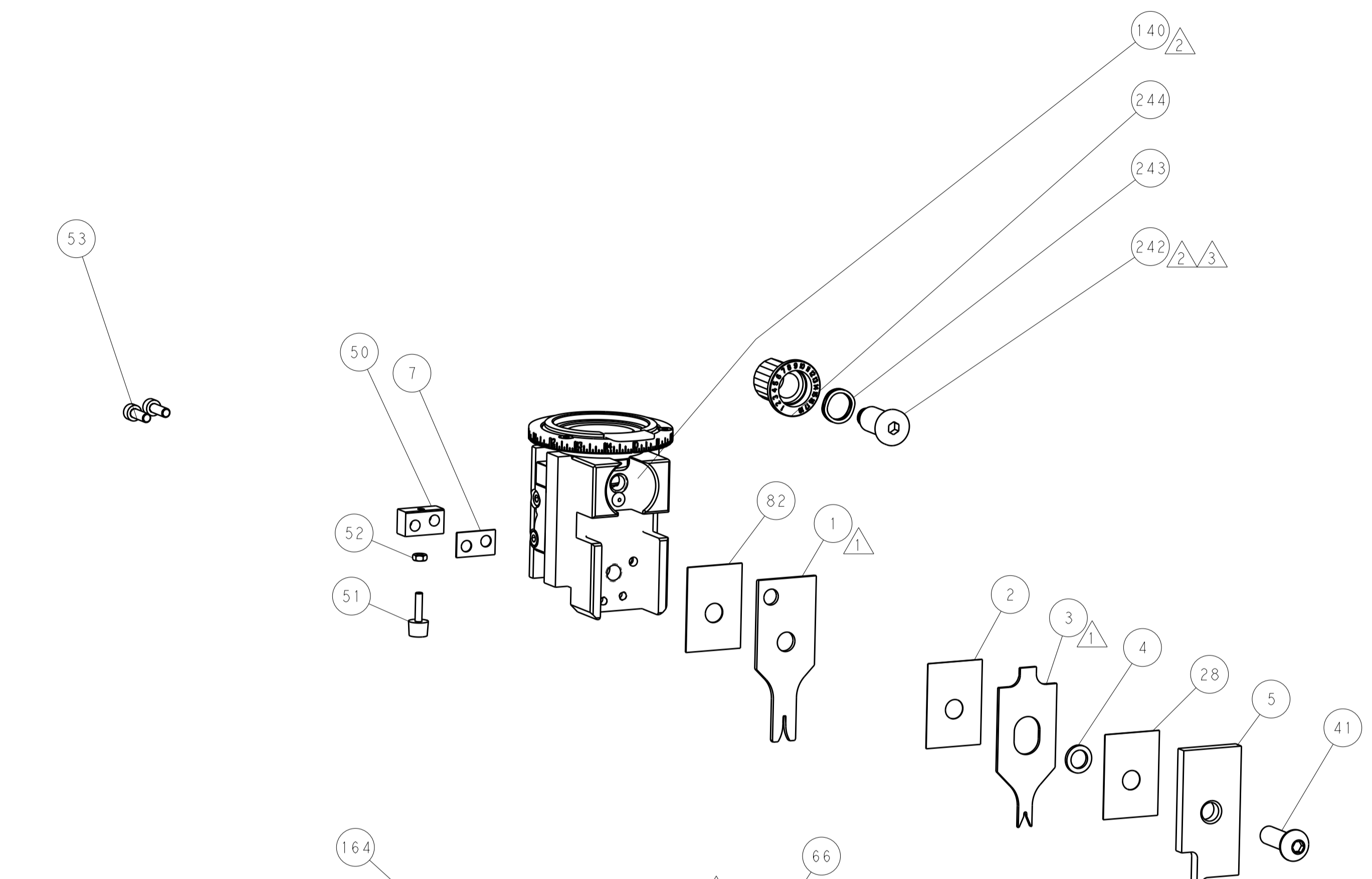
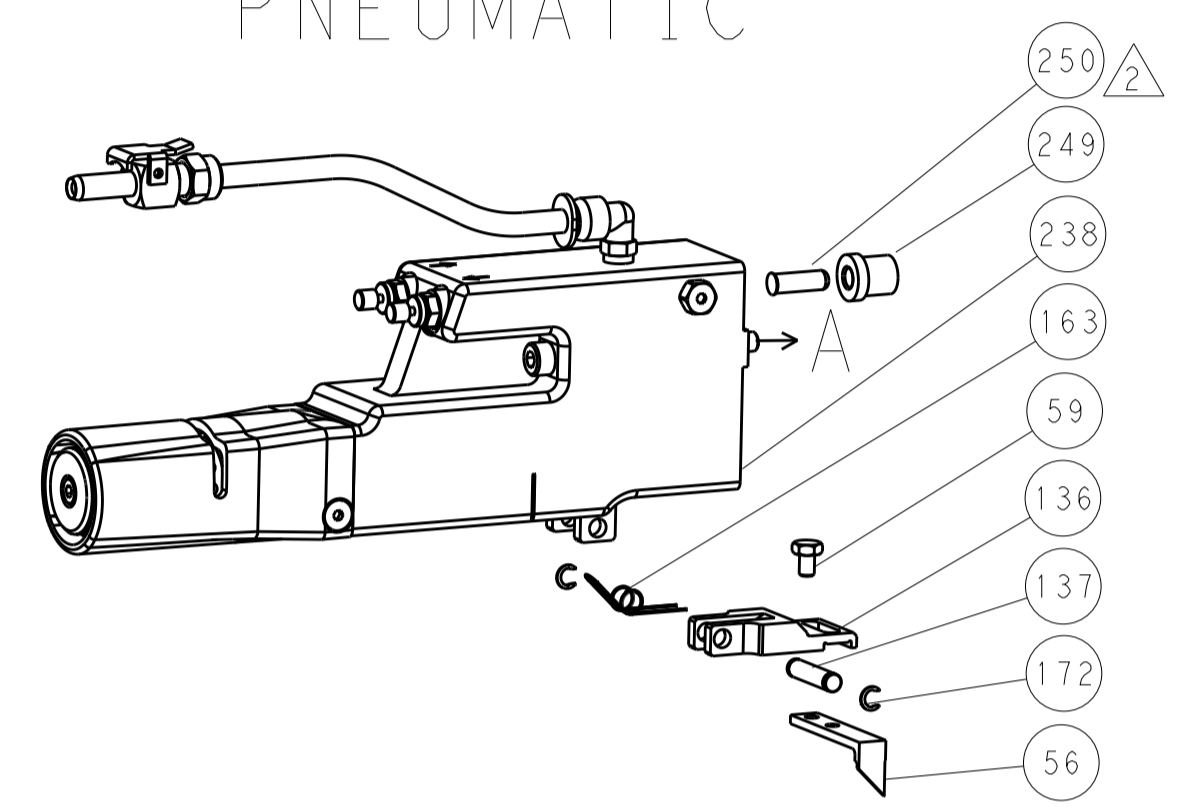

TERMINAL SUPPORT LOCATION

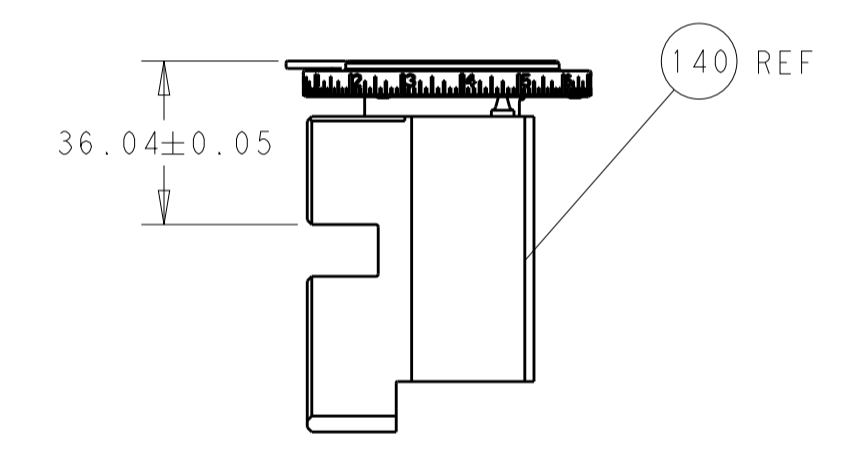

RAM SET-UP

ITEM 30 LOCATED AT FRONT HOLES

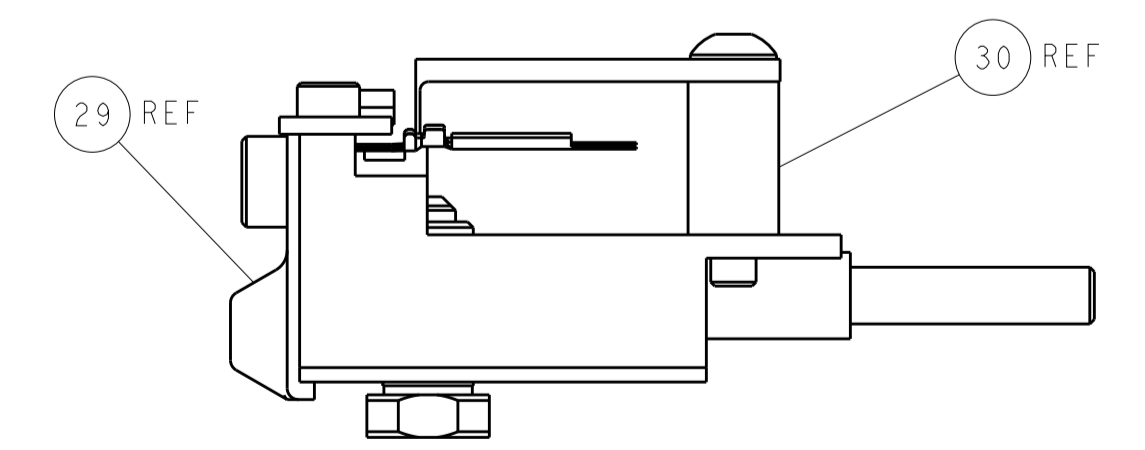

FEED TRACK POSITION GUIDE BY INSULATION BARREL

CAM POSITIONS

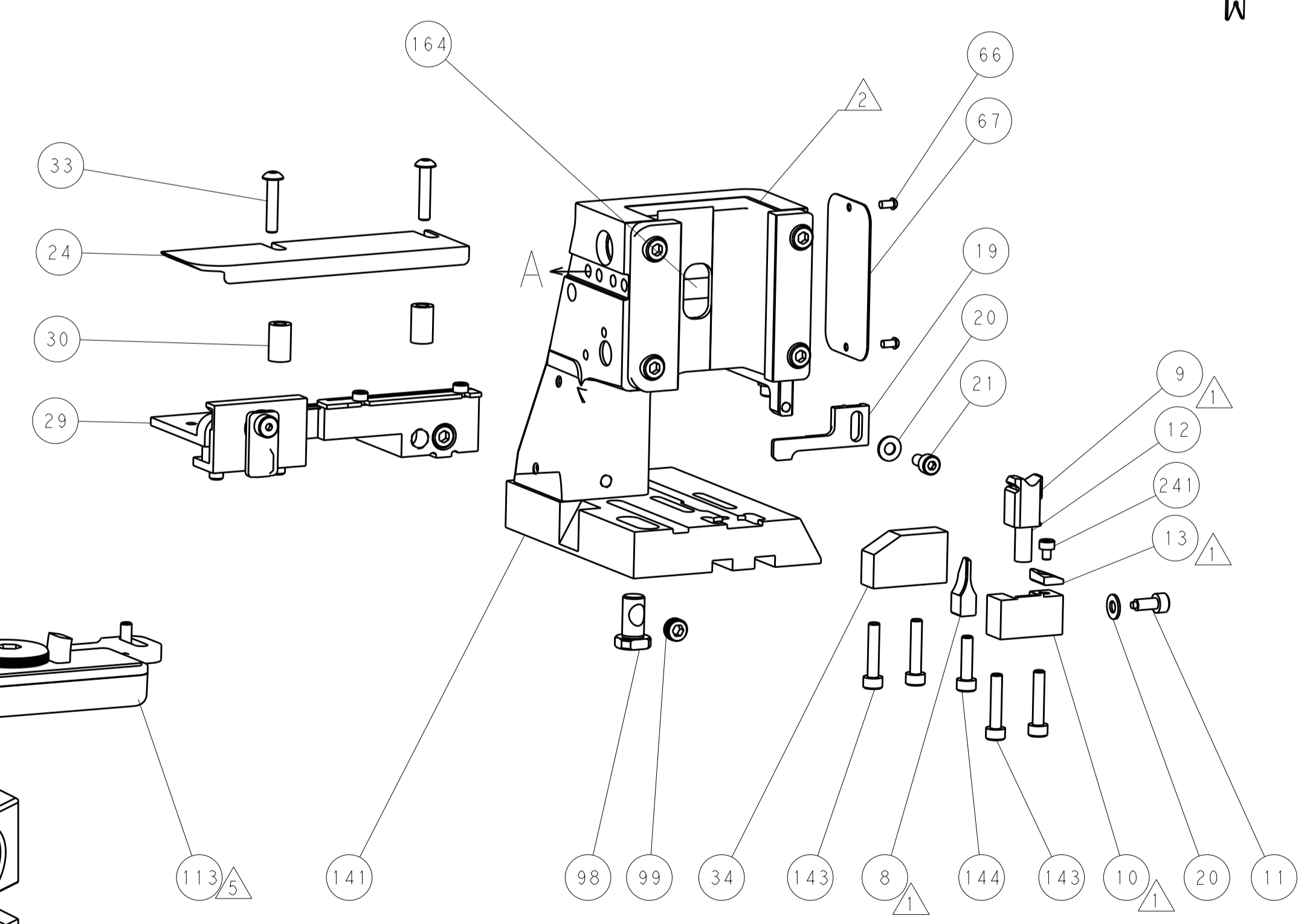
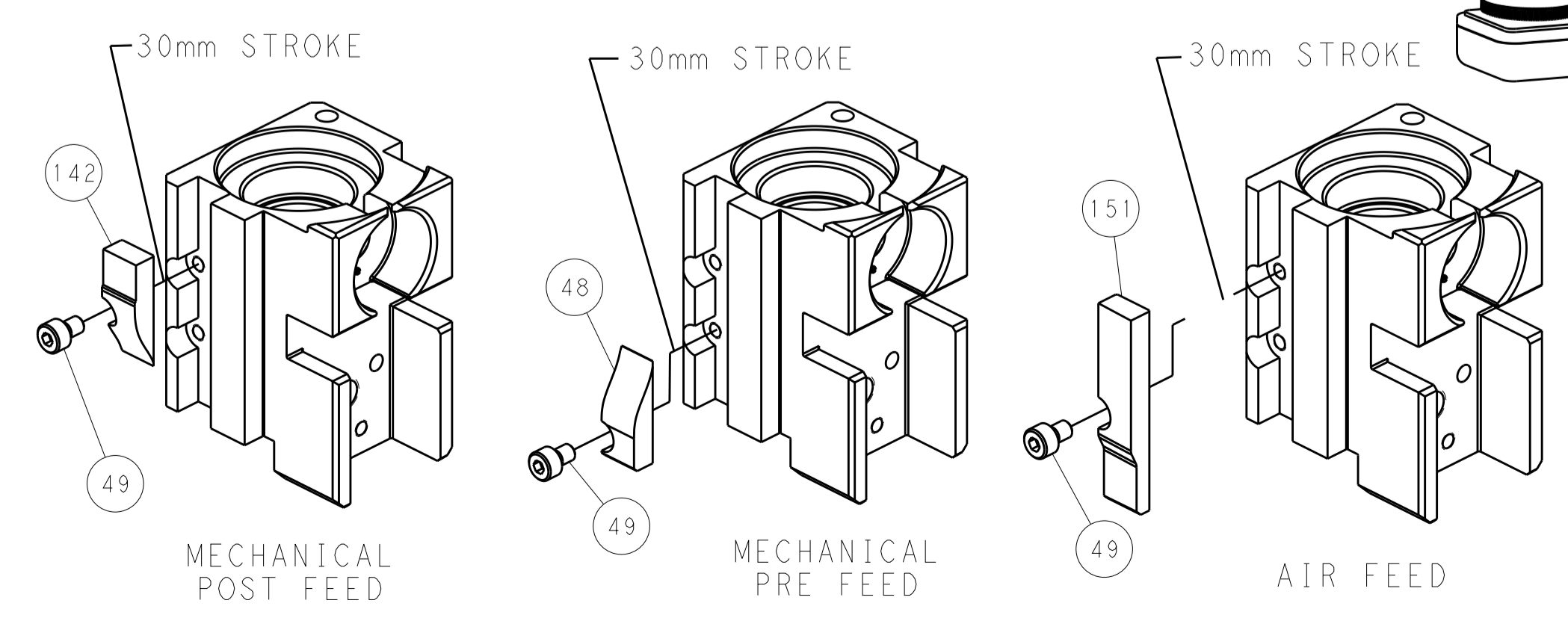

PACIFIC VERSION
 Shown on sheets 3 of 4 & 4 of 4
 (Atlantic version shown on sheets 1 of 4 & 2 of 4)

DIMENSIONS:		TOLERANCES UNLESS OTHERWISE SPECIFIED:		DWN: C. CHEN 26MAR2012		TE Connectivity	
mm	0 PLC ±	1 PLC ±	2 PLC ±	3 PLC ±	4 PLC ±	Harrisburg, PA 17105-3608	
MATERIAL:		FINISH:		CHK: S. XI 26MAR2012		NAME: Ocean Side Feed Applicator	
				APVD: J. CRUZ 26MAR2012		SIZE: CAGE CODE: DRAWING NO: 00779 ©=2151428	
				PRODUCT SPEC:		RESTRICTED TO:	
				APPLICATION SPEC:		Customer Accessible Production Drawing	
				WEIGHT:		SCALE: 1:2 SHEET 4 OF 4 REV F	