

PRODUCT NUMBER
SEE TABLE

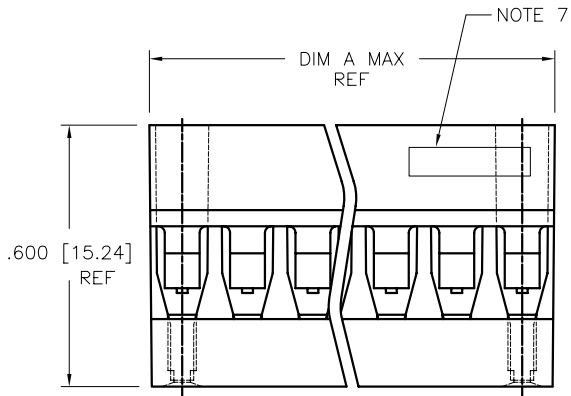

FIGURE 1

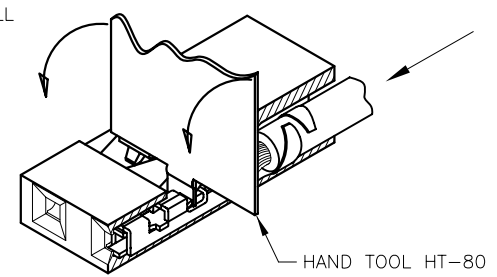
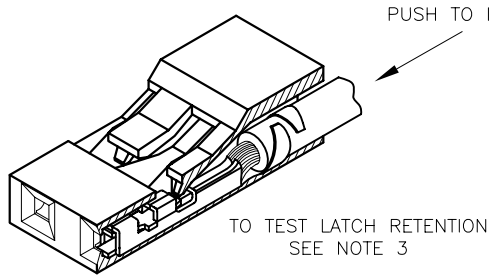

FIGURE 2

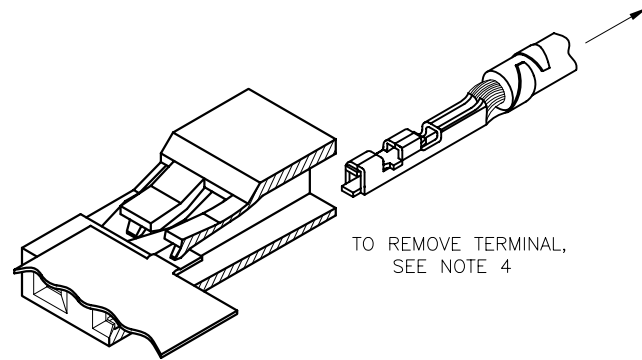

FIGURE 3

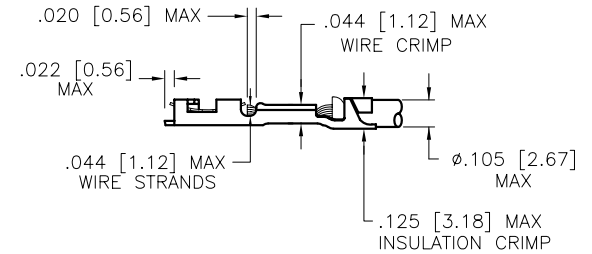
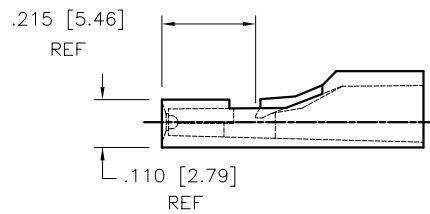
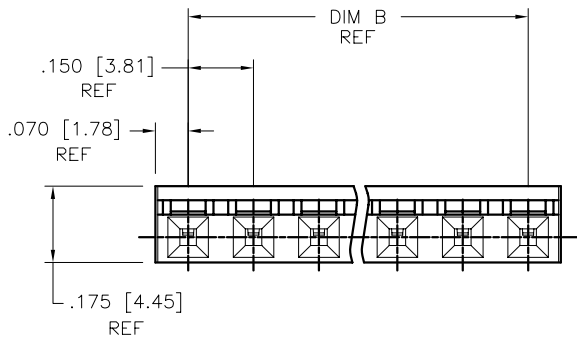

FIGURE 4
MAX CRIMP INFORMATION
SEE NOTE 5



Copyright FCI

mat'l. code SEE NOTE 1		surface	tolerance	projection	product family PV HOUSINGS
ltr	ec'n no	dr	date	tolerances unless otherwise specified	title
J	v51086	GAH	1995-12-18	angles	MINI LATCH HOUSING SINGLE ROW .150 [3.81] CC
K	v90985	RGD	1999-06-22	linear	
L	v03-1358	PJ	2004-02-09	0°±2°	INCH/MM
M	v05-0714	TAB	2005-07-29	dr	scale 2.5:1
N	v06-0419	HTB	2006-05-03	engr	dwg no
P	v07-0493	HTB	2007-07-30	chr	sheet 1 of 2
				appd	size
					65486
					A3
sheet	revision	P	P		type
index	sheet	1	2		Product Customer Drawing

PRODUCT NO.	NO. OF CAVITIES	DIM "A" MAX.	DIM "B"	MATERIAL COLOR	CUSTOMER RESTRICTED	MARKING STYLE
65486-001LF	1	.150/3.81	—	BLACK		
65486-002LF	2	.305/7.75	.150/3.81	BLACK		
65486-003LF	3	.455/11.56	.300/7.62	BLACK		
65486-004LF	4	.605/15.37	.450/11.43	BLACK		
65486-005LF	5	.755/19.18	.600/15.24	BLACK		
65486-006LF	6	.905/22.99	.750/19.05	BLACK		
65486-007LF	7	1.055/26.80	.900/22.86	BLACK		
65486-008LF	8	1.205/30.61	1.050/26.67	BLACK		
65486-009LF	9	1.355/34.42	1.200/30.48	BLACK		
65486-010LF	10	1.505/38.23	1.350/34.29	BLACK		
65486-011LF	11	1.655/42.04	1.500/38.10	BLACK		
65486-012LF	12	1.805/45.85	1.650/41.91	BLACK		
65486-013LF	13	1.955/49.66	1.800/45.72	BLACK		
65486-014LF	14	2.105/53.47	1.950/49.53	BLACK		
65486-015LF	15	2.255/57.28	2.100/53.34	BLACK		
65486-016LF	16	2.405/61.09	2.250/57.15	BLACK		
65486-017LF	17	2.555/64.90	2.400/60.96	BLACK		
65486-018LF	18	2.705/68.71	2.550/64.77	BLACK		
65486-019LF	19	2.855/72.52	2.700/68.58	BLACK		
65486-020LF	20	3.005/76.33	2.850/72.39	BLACK		
65486-021LF	21	3.155/80.14	3.000/76.20	BLACK		
65486-022LF	22	3.305/83.95	3.150/80.01	BLACK		
65486-023LF	23	3.455/87.76	3.300/83.82	BLACK		
65486-024LF	24	3.605/91.57	3.450/87.63	BLACK		
65486-025LF	25	3.755/95.38	3.600/91.44	BLACK		
65486-026LF	26	3.905/99.19	3.750/95.25	BLACK		
65486-027LF	27	4.055/103.00	3.900/99.06	BLACK		
65486-028LF	28	4.205/106.81	4.050/102.87	BLACK		
65486-029LF	29	4.355/110.62	4.200/106.68	BLACK		
65486-030LF	30	4.505/114.43	4.350/110.49	BLACK		
65486-031LF	31	4.655/118.24	4.500/114.30	BLACK		
65486-032LF	5	.755/19.18	.600/15.24	BLUE	*	
65486-033LF	9	1.355/34.42	1.200/30.48	BLUE	*	
65486-034LF	7	1.055/26.80	.900/22.86	BLUE	*	
65486-035LF	11	1.655/42.04	1.500/38.10	BLACK		STYLE A
65486-036LF	31	4.655/118.24	4.500/114.30	BLACK		STYLE A
65486-037LF	3	.455/11.56	.300/7.62	BLACK	*	STYLE A
65486-038LF	6	.905/22.99	.750/19.05	BLACK	*	STYLE A
65486-039LF	6	.905/22.99	.750/19.05	BLACK		STYLE B
65486-040LF	4	.605/15.37	.450/11.43	BLACK		STYLE C

NONE

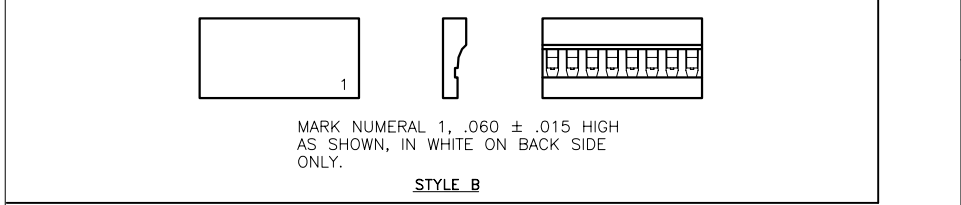
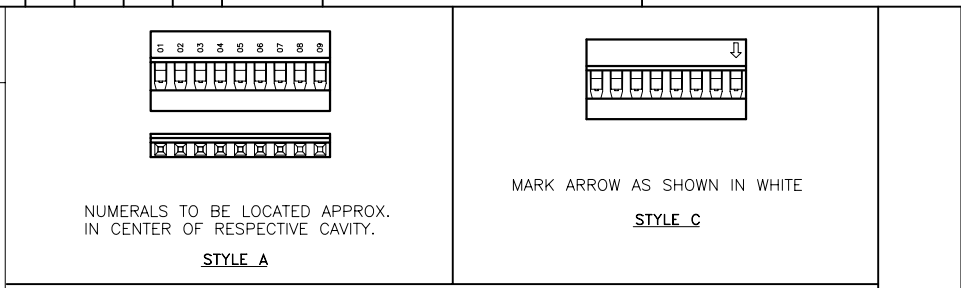

NOTES:

- MOLDING MATERIAL: BLUE-MODIFIED POLYPHENYLENE OXIDE, MEETING UL 94V-1. MOLDING MATERIAL: BLACK-MODIFIED POLYPHENYLENE ETHER, MEETING UL 94V-0.
- PIN LENGTH TO BE .210/5.33 MIN. RECOMMENDED PIN LENGTH IS .225±.015[5.72±0.38].
- TO LATCH TERMINAL PUSH AS SHOWN IN FIGURE 1. BE SURE THAT LATCH SNAPS DOWN.
- TO REMOVE TERMINAL; PUSH TERMINAL FOWARD, LIFT LATCH WITH HAND TOOL AS SHOWN IN FIGURES 2 & 3. DAMAGE TO LATCH MAY OCCUR IF LIFTED MORE THAN A 25° ANGLE TO TOP OF HOUSING.
- MAX. WIRE CRIMP AND WIRE STRANDS ARE SHOWN IN FIG. 4. IF THIS IS EXCEEDED, LATCHING WILL NOT BE SATISFACTORY. SEE MINI PV™ TERMINAL APPLICATION TA-75 FOR CORRECT CRIMP HEIGHT FOR EACH DIFFERENT WIRE SIZE. PRODUCT SPECIFICATION: BUS-12-067.
- THIS HOUSING IS INTENDED FOR USE WITH MINI PV™ TERMINAL WITH 20-32 GAUGE WIRE MEETING SPECIFICATIONS SHOWN IN FIGURE 4.
- PART NO. AND OR LOGO WILL APPEAR IN THIS AREA IF SIZE PERMITS UNLESS NOTED OTHERWISE PER MARKING STYLE, MARKING WILL BE "6 POINT TYPE SET" (APPROX. AREA PER NUMERAL OR LETTER IS .056/1.42 WIDE X .070/1.78 HIGH).
- PRODUCT MEETS EUROPEAN UNION DIRECTIVES AND OTHER COUNTRY REGULATIONS AS DESCRIBED IN GS-22-008.
- THE PRODUCT IS NOT INTENDED TO BE EXPOSED TO MANUFACTURING SOLDER PROCESS.

mat'l. code		surface		tolerance		projection		product family	
SEE NOTE 1		✓				⊕		PV HOUSINGS	
ltr	ecn no	dr	date	tolerances unless otherwise specified		INCH/MM		title	
P				angles	linear	3:1		MINI LATCH HOUSING	
				0°±2'				SINGLE ROW .150 [3.81] CC	
				dr	G. HULL	1995-12-18		dwg no	
				engr	T. HANNA	1995-12-18		sheet 2 of 2	
				chr	T. BREWBAKER	1995-12-18		size	
				appd	T. HANNA	1995-12-18		A3	
sheet		revision						type	
index		sheet						Product Customer Drawing	



Copyright FCI