

DESCRIPTION: M12 MALE - PANEL MOUNT (REAR) - SOLDER CUP - 12 POS.

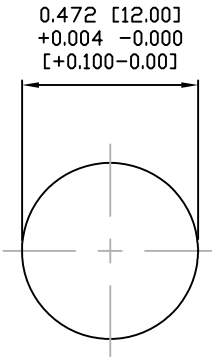

PANEL CUTOUT

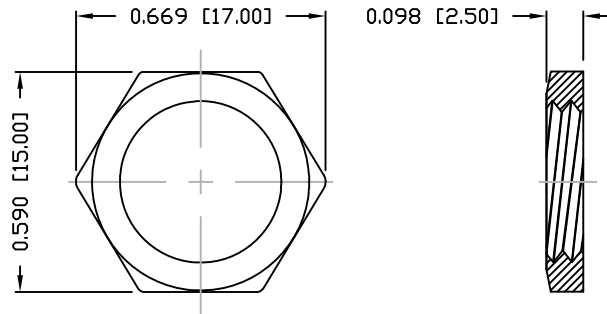

NUT

NOTE:

MATERIAL	
HOUSING:	PBT UL94V-0, BLACK
CONTACT:	BRASS
SHELL:	BRASS
NUT:	BRASS
O-RING:	EPDM
FINISH	
CONTACT:	GOLD PLATED
	OVER 50μ" NICKEL
SHELL:	NICKEL PLATED
NUT:	NICKEL PLATED
ELECTRICAL	
RATED CURRENT:	1.5A
RATED VOLTAGE:	30V
INSULATION RESISTANCE:	100 MΩhms MIN.
CONTACT RESISTANCE:	10 mΩhms MAX.
WATER PROOF:	IP67
ENVIRONMENT	
OPERATION TEMPERATURE:	-40°C TO +85°C
MAX WIRE AWG:	26

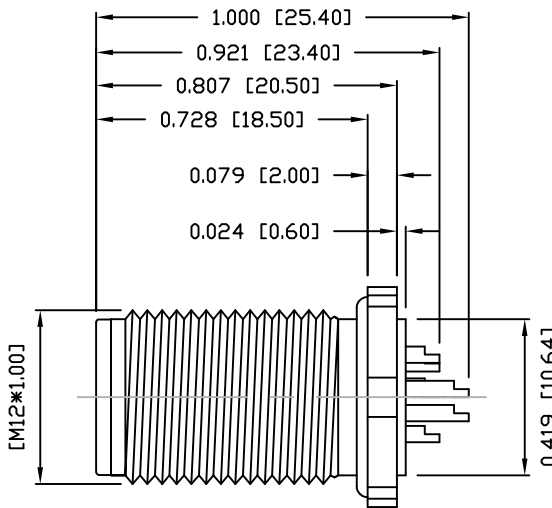
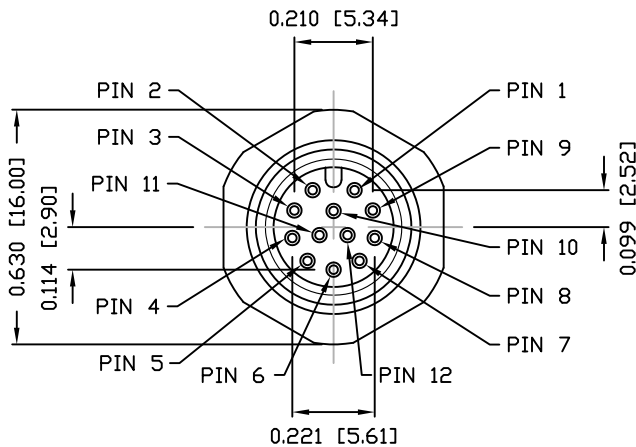

859-012-103R00Y

3 = BRASS/NICKEL SHELL & NUT
 S = STAINLESS STEEL SHELL & NUT

1 = GOLD FLASH
 4 = 10μ" GOLD

RoHS COMPLIANT

UNITS = INCHES [MM]

DO NOT SCALE FROM DRAWING



THESE DRAWINGS AND SPECIFICATIONS ARE THE PROPERTY OF NorComp AND SHALL NOT BE REPRODUCED, COPIED OR USED AS THE BASIS FOR THE MANUFACTURE OR SALE OF APPARATUS WITHOUT WRITTEN PERMISSION.

DRAWN:

M. SIGMON

DATE:

03-08-16

NorComp

SCALE:

NTS

SHEET

1

OF

1

REV

3

DWG NO.

859-012-103R00Y