

Pb THIS PRODUCT MANUFACTURED WITH LEAD-FREE PROCESSING

DO NOT SCALE FROM THIS PRINT

END TO END	"B"
DV TO DV	.820 [20.82]

EQRD-XXX-XX.XX-XXX-XXX-X-X

No OF POSITIONS
-026, -052, -078
(PER ROW)

LENGTH
-XX.XX (INCHES)
(01.72[43.69] MIN)
(SEE NOTE 8)
(SEE NOTE 9)

END OPTION
-F: SCREW OPTION FIRST END ONLY
-S: SCREW OPTION SECOND END ONLY
-B: SCREW OPTION BOTH ENDS
-N: NO HOUSINGS EITHER END
(SEE SHEET 3, FIGURE 3 FOR DETAILS)
(LEAVE BLANK FOR STANDARD HOUSINGS)

WIRING OPTION
-1: PIN 1 TO PIN 1
-2: PIN 1 TO PIN 2
-3: PIN 1 TO PIN N-1
-4: PIN 1 TO PIN N
(SEE TABLE 6, SHEET 4)

FIRST END
-TTR: TERMINAL, TOP, RIGHT
-TTL: TERMINAL, TOP, LEFT
-TBR: TERMINAL, BOTTOM, RIGHT
-TBL: TERMINAL, BOTTOM, LEFT
-STR: SOCKET, TOP, RIGHT
-STL: SOCKET, TOP, LEFT
-SBR: SOCKET, BOTTOM, RIGHT
-SBL: SOCKET, BOTTOM, LEFT

SECOND END
-TTR: TERMINAL, TOP, RIGHT
-TTL: TERMINAL, TOP, LEFT
-TBR: TERMINAL, BOTTOM, RIGHT
-TBL: TERMINAL, BOTTOM, LEFT
-STR: SOCKET, TOP, RIGHT
-STL: SOCKET, TOP, LEFT
-SBR: SOCKET, BOTTOM, RIGHT
-SBL: SOCKET, BOTTOM, LEFT

FIG 1
(EQRD-026-XX.XX-TTL-STL-X SHOWN)

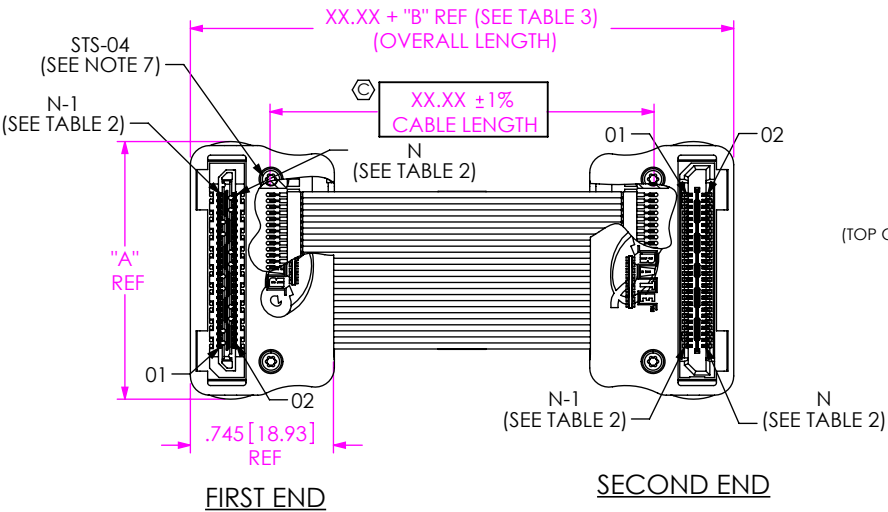

HDRL-12
(SEE NOTE 5)
(TOP CABLE REMOVED FOR CLARITY)

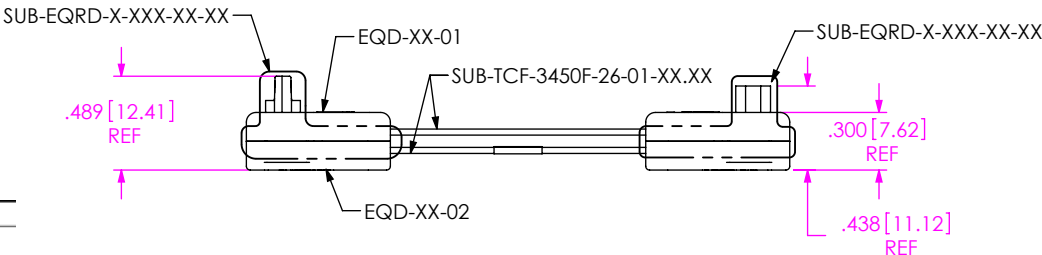
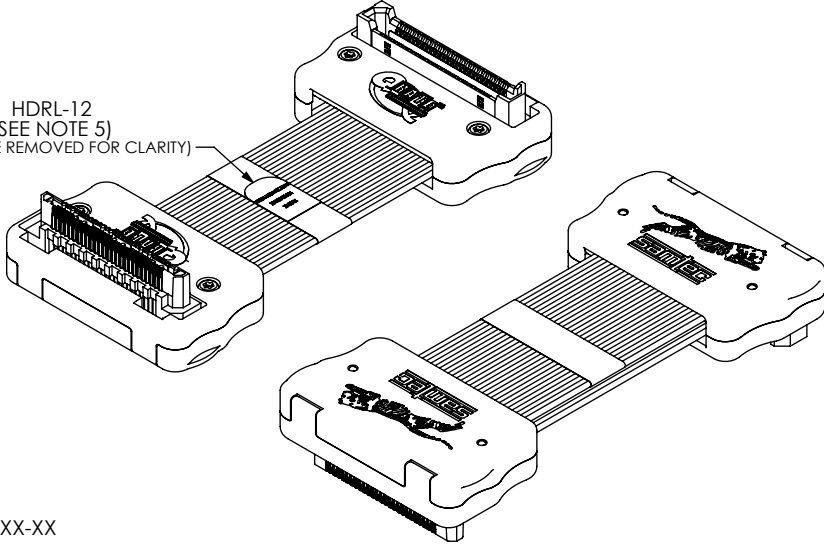

- NOTES:
1. REPRESENTS A CRITICAL DIMENSION.
 2. PARTS TO BE PROCESSED PER SAMTEC BOUNDARY DOCUMENTS GUIDELINES.
 3. ALL ASSEMBLIES TO BE 100% ELECTRICALLY TESTED.
 4. ALL ASSEMBLIES TO BE 100% HI-POT TESTED AT 300V.
 5. LABEL TO BE CENTERED ON LOWER CABLE AS SHOWN. LABEL TO CONTAIN:
LINE 1 - PART NUMBER "EQRD-XXX-XX.XX-XXX-XXX-X"
LINE 2 - SHOP ORDER NUMBER "XXXXXX"
LINE 3 - DATE CODE "XXXXX"
 6. FOR PACKAGING REQUIREMENTS REFERENCE PACKAGING STANDARDS.
 7. TIGHTEN STS-04 FASTENERS TO 1.4-1.7 IN-LBS (4 PLCS).
 8. SUB-TCF LENGTH IS EQUAL TO EQRD LENGTH.
 9. CABLE LENGTHS LONGER THAN 40.00 INCHES ARE NOT SUPPORTED BY S.I. TEST DATA.
 10. REFER TO PREP-SPEC DRAWING FOR CABLE DIMENSIONS.
ASSEMBLY USES STANDARD PCB PREP.

# OF POSITIONS	N	N-1
-026	26	25
-052	52	51
-078	78	77

# OF POSITIONS	"A"	EQD-XX-01	EQD-XX-02	SUB-TCF-3450F-XX-XX-XX-XX		SUB-EQRD-X-XXX-XX-XX-X
				PART #	QTY	
-026	1.300 [33.02]	EQD-01-01	EQD-01-02	SUB-TCF-3450F-26-01-XX-XX	2	SUB-EQRD-X-026-XX-XX-X
-052	2.276 [57.81]	EQD-02-01	EQD-02-02	SUB-TCF-3450F-26-01-XX-XX	4	SUB-EQRD-X-052-XX-XX-X
-078	3.253 [82.63]	EQD-03-01	EQD-03-02	SUB-TCF-3450F-26-01-XX-XX	6	SUB-EQRD-X-078-XX-XX-X

SEE TABLE 8 (SHEET 4)

TOLERANCES DO NOT APPLY TO REFERENCE DIMENSIONS, UNLESS OTHERWISE SPECIFIED, DIMENSIONS ARE IN INCHES.
TOLERANCES ARE:
DECIMALS .XX: ±.01 [3]
.XXX: ±.005 [13]
.XXXX: ±.0020 [051]
ANGLES 2°
MATERIAL: DO NOT SCALE DRAWING
PLATING: -S GOLD: 30µ" CONTACT

PROPRIETARY NOTE
THIS DOCUMENT CONTAINS CONFIDENTIAL AND PROPRIETARY INFORMATION AND ALL DESIGN, MANUFACTURING, REPRODUCTION, USE, PATENT RIGHTS AND SALES RIGHTS ARE EXPRESSLY RESERVED BY SAMTEC, INC. THIS DOCUMENT SHALL NOT BE DISCLOSED, IN WHOLE OR PART, TO ANY UNAUTHORIZED PERSON OR ENTITY NOR REPRODUCED, TRANSFERRED OR INCORPORATED IN ANY OTHER PROJECT IN ANY MANNER WITHOUT THE EXPRESS WRITTEN CONSENT OF SAMTEC, INC.



520 PARK EAST BLVD, NEW ALBANY, IN 47150
PHONE: 812-944-6733 FAX: 812-948-5047
e-Mail info@SAMTEC.com code 55322

DESCRIPTION:
0.8MM Q-RATE COAX CABLE ASSEMBLY
DWG. NO.
EQRD-XXX-XX.XX-XXX-XXX-X-X
BY: J. Riley 08/10/2009 SHEET 1 OF 4

FIRST END

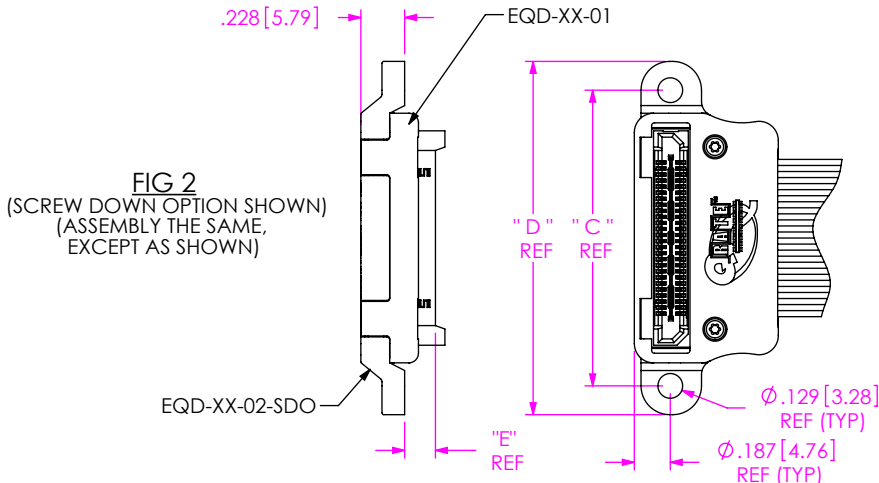
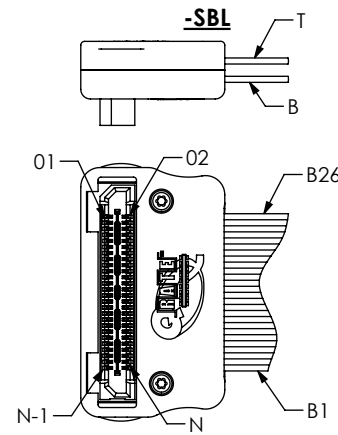
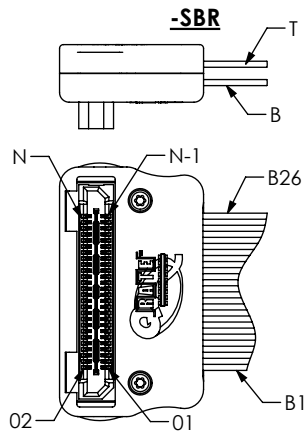
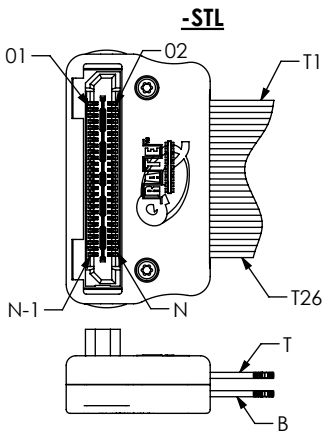
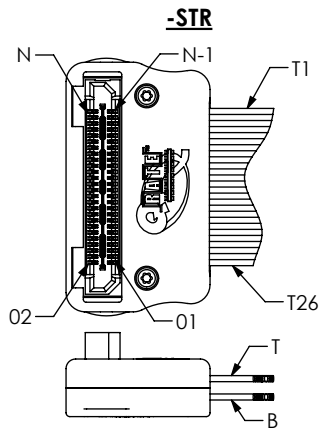
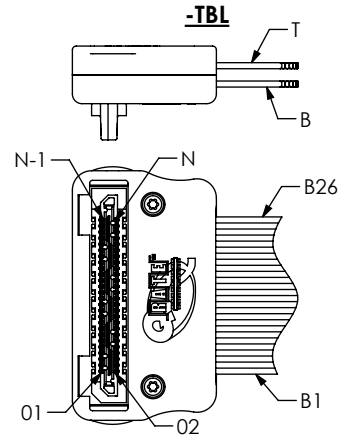
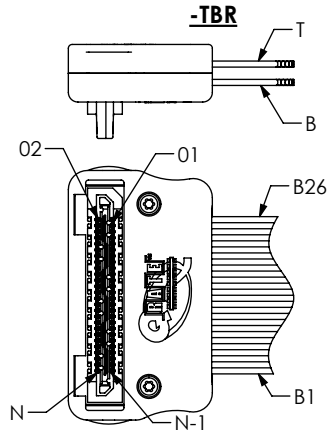
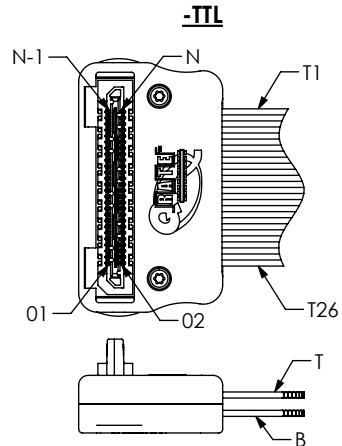
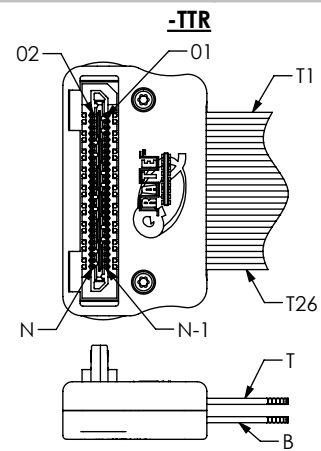

# OF POSITIONS	"C"	"D"	EQD-XX-02-SDO
-026	1.540 [39.12]	1.840 [46.74]	EQD-01-02-SDO
-052	2.516 [63.91]	2.816 [71.53]	EQD-02-02-SDO
-078	3.492 [88.70]	3.792 [96.32]	EQD-03-02-SDO

# OF POSITIONS	"E"
-TXX	.135 [3.43]
-SXX	.160 [4.08]

PROPRIETARY NOTE
 THIS DOCUMENT CONTAINS CONFIDENTIAL AND PROPRIETARY INFORMATION AND ALL DESIGN, MANUFACTURING, REPRODUCTION, USE, PATENT RIGHTS AND SALES RIGHTS ARE EXPRESSLY RESERVED BY SAMTEC, INC. THIS DOCUMENT SHALL NOT BE DISCLOSED, IN WHOLE OR PART, TO ANY UNAUTHORIZED PERSON OR ENTITY NOR REPRODUCED, TRANSFERRED OR INCORPORATED IN ANY OTHER PROJECT IN ANY MANNER WITHOUT THE EXPRESS WRITTEN CONSENT OF SAMTEC, INC.

DO NOT SCALE DRAWING



520 PARK EAST BLVD, NEW ALBANY, IN 47150
 PHONE: 812-944-6733 FAX: 812-948-5047
 e-Mail info@SAMTEC.com code 55322

DESCRIPTION:
 0.8MM Q-RATE COAX CABLE ASSEMBLY
 DWG. NO.
 EQRD-XXX-XX.XX-XXX-XXX-X-X
 BY: J. Riley 08/10/2009 SHEET 2 OF 4

SECOND END

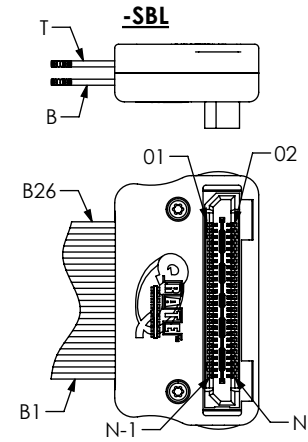
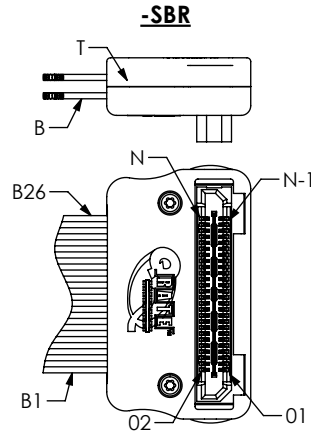
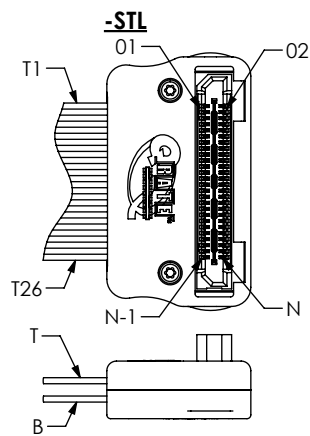
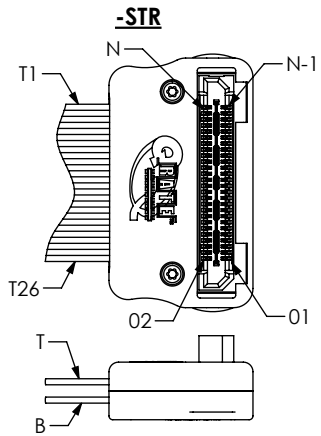
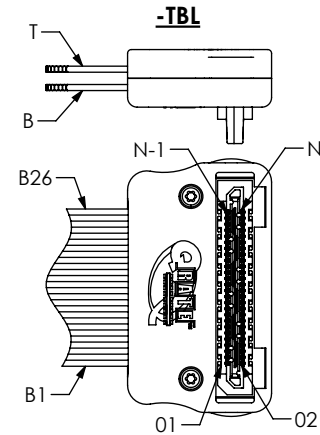
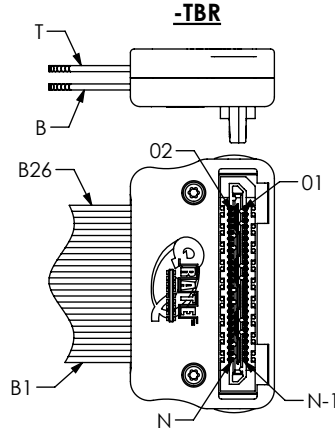
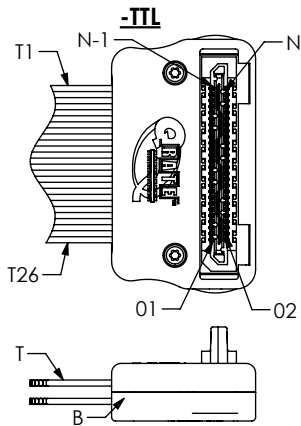
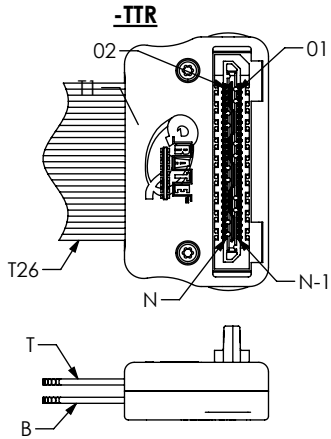
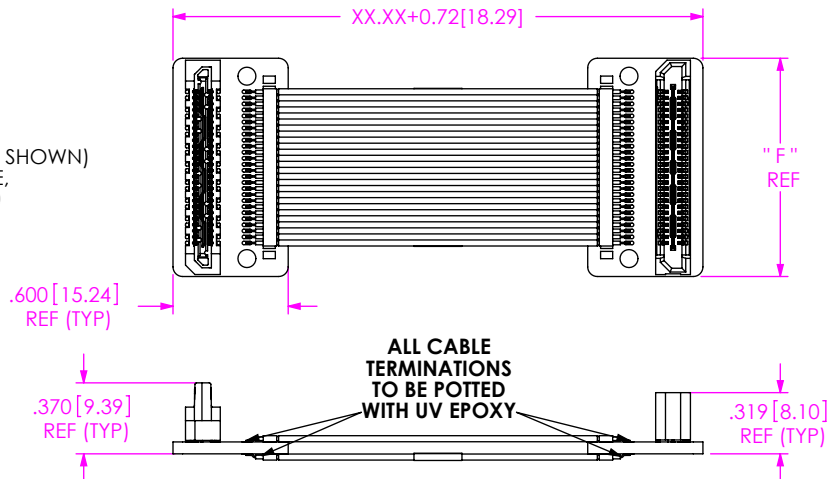

FIG 3
(EQRD-026-XX.XX-TTL-STL-X-N SHOWN)
(ASSEMBLY THE SAME,
EXCEPT AS SHOWN)



# OF POSITIONS	"F"
-026	1.136 [28.85]
-052	2.113 [53.67]
-078	3.089 [78.46]

PROPRIETARY NOTE
THIS DOCUMENT CONTAINS CONFIDENTIAL AND PROPRIETARY INFORMATION AND ALL DESIGN, MANUFACTURING, REPRODUCTION, USE, PATENT RIGHTS AND SALES RIGHTS ARE EXPRESSLY RESERVED BY SAMTEC, INC. THIS DOCUMENT SHALL NOT BE DISCLOSED, IN WHOLE OR PART, TO ANY UNAUTHORIZED PERSON OR ENTITY NOR REPRODUCED, TRANSFERRED OR INCORPORATED IN ANY OTHER PROJECT IN ANY MANNER WITHOUT THE EXPRESS WRITTEN CONSENT OF SAMTEC, INC.

DO NOT SCALE DRAWING



520 PARK EAST BLVD, NEW ALBANY, IN 47150
PHONE: 812-944-6733 FAX: 812-948-5047
e-Mail info@SAMTEC.com code 55322

DESCRIPTION:
0.8MM Q-RATE COAX CABLE ASSEMBLY

DWG. NO.
EQRD-XXX-XX.XX-XXX-XXX-X-X

BY: J. Riley 08/10/2009 SHEET 3 OF 4

REVISION K

TABLE 6

FIRST END OPTION	FIRST END SUB-EQRD-X-XXX-XX-01	WRING OPTION	FIRST END PIN #	SECOND END PIN #	WIRE #	SECOND END OPTION (SUB-EQRD-X-XXX-XX-XX)							
						-TTR	-TTL	-TBR	-TBL	-STR	-STL	-SBR	-SBL
-TTR	-T-XXX-01-01	1	1	1	T1	-T-XXX-02-02	N/A	N/A	-T-XXX-01-02	N/A	-S-XXX-01-01	-S-XXX-02-01	N/A
		2	1	2	T1	-T-XXX-02-01	N/A	N/A	-T-XXX-01-01	N/A	-S-XXX-01-02	-S-XXX-02-02	N/A
		3	1	N-1	T1	N/A	-T-XXX-01-01	-T-XXX-02-01	N/A	-S-XXX-02-02	N/A	N/A	-S-XXX-01-02
		4	1	N	T1	N/A	-T-XXX-01-02	-T-XXX-02-02	N/A	-S-XXX-02-01	N/A	N/A	-S-XXX-01-01
-TTL	-T-XXX-02-01	1	1	1	B20	N/A	-T-XXX-01-02	-T-XXX-02-02	N/A	-S-XXX-02-01	N/A	N/A	-S-XXX-01-01
		2	1	2	B20	N/A	-T-XXX-01-01	-T-XXX-02-01	N/A	-S-XXX-02-02	N/A	N/A	-S-XXX-01-02
		3	1	N-1	B20	-T-XXX-02-01	N/A	N/A	-T-XXX-01-01	N/A	-S-XXX-01-02	-S-XXX-02-02	N/A
		4	1	N	B20	-T-XXX-02-02	N/A	N/A	-T-XXX-01-02	N/A	-S-XXX-01-01	-S-XXX-02-01	N/A
-TBR	-T-XXX-01-01	1	1	1	B20	N/A	-T-XXX-01-02	-T-XXX-02-02	N/A	-S-XXX-02-01	N/A	N/A	-S-XXX-01-01
		2	1	2	B20	N/A	-T-XXX-01-01	-T-XXX-02-01	N/A	-S-XXX-02-02	N/A	N/A	-S-XXX-01-02
		3	1	N-1	B20	-T-XXX-02-01	N/A	N/A	-T-XXX-01-01	N/A	-S-XXX-01-02	-S-XXX-02-02	N/A
		4	1	N	B20	-T-XXX-02-02	N/A	N/A	-T-XXX-01-02	N/A	-S-XXX-01-01	-S-XXX-02-01	N/A
-TBL	-T-XXX-02-01	1	1	1	T1	-T-XXX-02-02	N/A	N/A	-T-XXX-01-02	N/A	-S-XXX-01-01	-S-XXX-02-01	N/A
		2	1	2	T1	-T-XXX-02-01	N/A	N/A	-T-XXX-01-01	N/A	-S-XXX-01-02	-S-XXX-02-02	N/A
		3	1	N-1	T1	N/A	-T-XXX-01-01	-T-XXX-02-01	N/A	-S-XXX-02-02	N/A	N/A	-S-XXX-01-02
		4	1	N	T1	N/A	-T-XXX-01-02	-T-XXX-02-02	N/A	-S-XXX-02-01	N/A	N/A	-S-XXX-01-01
-STR	-S-XXX-01-01	1	1	1	T20	N/A	-T-XXX-01-01	-T-XXX-02-01	N/A	-S-XXX-02-02	N/A	N/A	-S-XXX-01-02
		2	1	2	T20	N/A	-T-XXX-01-02	-T-XXX-02-02	N/A	-S-XXX-02-01	N/A	N/A	-S-XXX-01-01
		3	1	N-1	T20	-T-XXX-02-02	N/A	N/A	-T-XXX-01-02	N/A	-S-XXX-01-01	-S-XXX-02-01	N/A
		4	1	N	T20	-T-XXX-02-01	N/A	N/A	-T-XXX-01-01	N/A	-S-XXX-01-02	-S-XXX-02-02	N/A
-STL	-S-XXX-02-01	1	1	1	B1	-T-XXX-02-01	N/A	N/A	-T-XXX-01-01	N/A	-S-XXX-01-02	-S-XXX-02-02	N/A
		2	1	2	B1	-T-XXX-02-02	N/A	N/A	-T-XXX-01-02	N/A	-S-XXX-01-01	-S-XXX-02-01	N/A
		3	1	N-1	B1	N/A	-T-XXX-01-02	-T-XXX-02-02	N/A	-S-XXX-02-01	N/A	N/A	-S-XXX-01-02
		4	1	N	B1	N/A	-T-XXX-01-01	-T-XXX-02-01	N/A	-S-XXX-02-02	N/A	N/A	-S-XXX-01-01
-SBR	-S-XXX-01-01	1	1	1	B1	-T-XXX-02-01	N/A	N/A	-T-XXX-01-01	N/A	-S-XXX-01-02	-S-XXX-02-02	N/A
		2	1	2	B1	-T-XXX-02-02	N/A	N/A	-T-XXX-01-02	N/A	-S-XXX-01-01	-S-XXX-02-01	N/A
		3	1	N-1	B1	N/A	-T-XXX-01-02	-T-XXX-02-02	N/A	-S-XXX-02-01	N/A	N/A	-S-XXX-01-02
		4	1	N	B1	N/A	-T-XXX-01-01	-T-XXX-02-01	N/A	-S-XXX-02-02	N/A	N/A	-S-XXX-01-01
-SBL	-S-XXX-02-01	1	1	1	T20	N/A	-T-XXX-01-01	-T-XXX-02-01	N/A	-S-XXX-02-02	N/A	N/A	-S-XXX-01-02
		2	1	2	T20	N/A	-T-XXX-01-02	-T-XXX-02-02	N/A	-S-XXX-02-01	N/A	N/A	-S-XXX-01-01
		3	1	N-1	T20	-T-XXX-02-02	N/A	N/A	-T-XXX-01-02	N/A	-S-XXX-01-01	-S-XXX-02-01	N/A
		4	1	N	T20	-T-XXX-02-01	N/A	N/A	-T-XXX-01-01	N/A	-S-XXX-01-02	-S-XXX-02-02	N/A

TABLE 7
SIGNAL MAP

POSITION	1	3	5	7	...	N-1
SIGNAL	S	S	S	S		S
SIGNAL	S	S	S	S		S
POSITION	2	4	6	8	...	N

(GROUND BLADE CONNECTED TO COAX SHIELD)

PROPRIETARY NOTE

THIS DOCUMENT CONTAINS CONFIDENTIAL AND PROPRIETARY INFORMATION AND ALL DESIGN, MANUFACTURING, REPRODUCTION, USE, PATENT RIGHTS AND SALES RIGHTS ARE EXPRESSLY RESERVED BY SAMTEC, INC. THIS DOCUMENT SHALL NOT BE DISCLOSED, IN WHOLE OR PART, TO ANY UNAUTHORIZED PERSON OR ENTITY NOR REPRODUCED, TRANSFERRED OR INCORPORATED IN ANY OTHER PROJECT IN ANY MANNER WITHOUT THE EXPRESS WRITTEN CONSENT OF SAMTEC, INC.



520 PARK EAST BLVD, NEW ALBANY, IN 47150
PHONE: 812-944-6733 FAX: 812-948-5047
e-Mail info@SAMTEC.com code 55322

DO NOT SCALE DRAWING

DESCRIPTION:
0.8MM Q-RATE COAX CABLE ASSEMBLY

DWG. NO.
EQRD-XXX-XX.XX-XXX-XXX-X-X

BY: J. Riley 08/10/2009 SHEET 4 OF 4

SHEET SCALE: 1:1