

**1.2A, 1.4MHz High Efficiency Synchronous DC-DC Buck Converter AP3417B**

## General Description

The AP3417B is a 1.4MHz fixed frequency, current mode, PWM synchronous buck (step-down) DC-DC converter, capable of driving a 1.2A load with high efficiency, excellent line and load regulation. The device integrates synchronous P-channel and N-channel power MOSFET switches with low on-resistance. It is ideal for powering portable equipment that runs from a single Li-ion battery.

A standard series of inductors are available from several different manufacturers optimized for use with the AP3417B. This feature greatly simplifies the design of switch-mode power supplies.

The AP3417B is available in SOT-23-5 package.

## Features

- Input Voltage Range: 2.5V to 5.5V
- Output Voltage: 0.6V to  $V_{IN}$
- ADJ Output
- Fixed 1.4MHz Frequency
- High Efficiency up to 95%
- Output Current: 1.2A
- Current Mode Control
- 100% Duty Cycle in Dropout
- Built-in Over Current Protection
- Built-in Short Circuit Protection
- Built-in Thermal Shutdown Protection
- Built-in UVLO Function
- Built-in Soft-start
- Built-in Input Over Voltage Protection (IOVP)

## Applications

- Set-top Box
- Datacom
- Portable Device
- Smart Phone

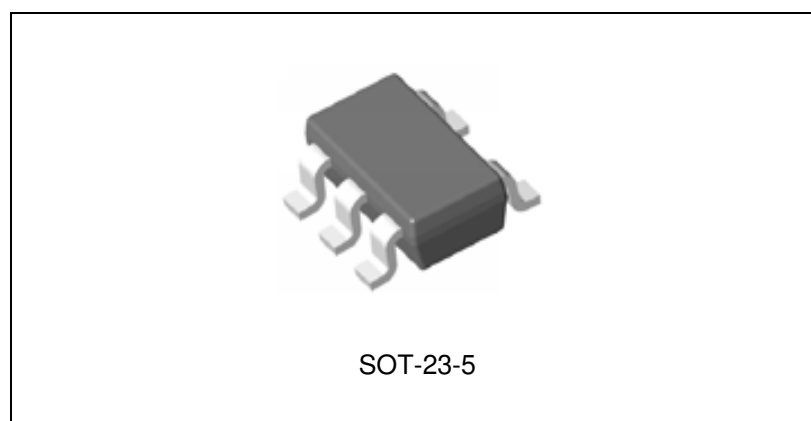

Figure 1. Package Type of AP3417B

**1.2A, 1.4MHz High Efficiency Synchronous DC-DC Buck Converter AP3417B**

**Pin Configuration**

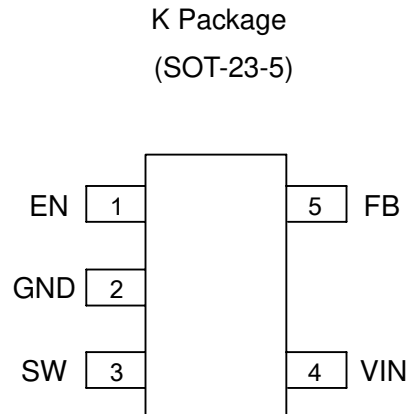

Figure 2. Pin Configuration of AP3417B (Top View)

**Pin Description**

Pin Number	Pin Name	Function
1	EN	Control input pin. Forcing this pin above 1.5V enables the IC. Forcing this pin below 0.4V shuts down the IC. When the IC is in shutdown mode, all functions are disabled to decrease the supply current below 1μA
2	GND	Ground pin
3	SW	Power switch output pin. Inductor connection to drain of the internal PFET and NFET switches
4	VIN	Supply input pin. Bypass to GND with a 4.7μF or greater ceramic capacitor
5	FB	This is the feedback pin of the device. Connect this pin directly to the output if the fixed output voltage version is used. For the adjustable version, an external resistor divider is connected to this pin

**1.2A, 1.4MHz High Efficiency Synchronous DC-DC Buck Converter AP3417B**

**Functional Block Diagram**

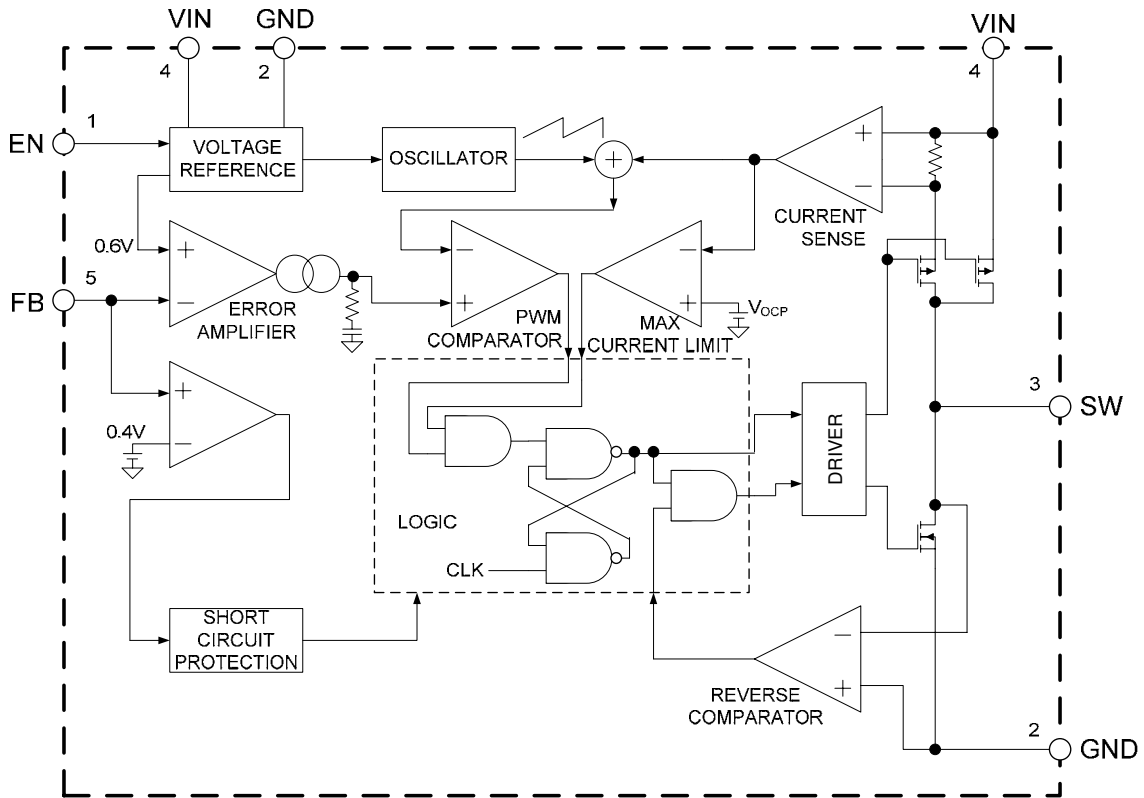
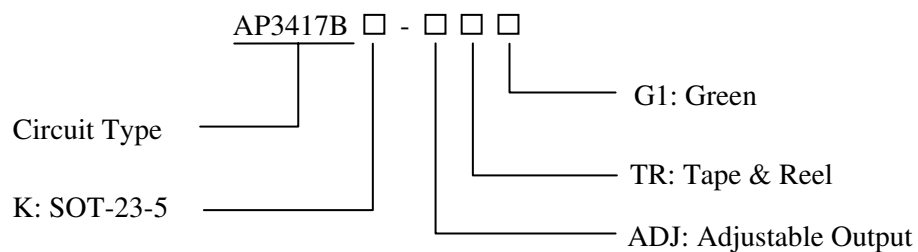

Figure 3. Functional Block Diagram of AP3417B

**Ordering Information**



Package	Temperature Range	Part Number	Marking ID	Packing Type
SOT-23-5	-40 to 85°C	AP3417BK-ADJTRG1	G2J	Tape & Reel

BCD Semiconductor's Pb-free products, as designated with "G1" suffix in the part number, are RoHS compliant and green.

**1.2A, 1.4MHz High Efficiency Synchronous DC-DC Buck Converter AP3417B****Absolute Maximum Ratings (Note 1)**

Parameter	Symbol	Value	Unit
Input Voltage	$V_{IN}$	-0.3 to 6.0	V
Feedback Voltage	$V_{FB}$	-0.3 to $V_{IN} + 0.3$	V
EN Pin Voltage	$V_{EN}$	-0.3 to $V_{IN} + 0.3$	V
SW Pin Voltage	$V_{SW}$	-0.3 to $V_{IN} + 0.3$	V
Thermal Resistance	$\theta_{JA}$	265	°C/W
Operating Junction Temperature	$T_J$	150	°C
Storage Temperature	$T_{STG}$	-65 to 150	°C
Lead Temperature (Soldering, 10sec)	$T_{LEAD}$	260	°C
ESD(Machine Model)		200	V
ESD(Human Body Model)		2000	V

Note 1: Stresses greater than those listed under “Absolute Maximum Ratings” may cause permanent damage to the device. These are stress ratings only, and functional operation of the device at these or any other conditions beyond those indicated under “Recommended Operating Conditions” is not implied. Exposure to “Absolute Maximum Ratings” for extended periods may affect device reliability.

**Recommended Operating Conditions**

Parameter	Symbol	Min	Max	Unit
Input Voltage	$V_{IN}$	2.5	5.5	V
Operating Ambient Temperature	$T_A$	-40	85	°C

**1.2A, 1.4MHz High Efficiency Synchronous DC-DC Buck Converter AP3417B****Electrical Characteristics** $V_{IN}=5V$ ,  $T_A=25^{\circ}C$ , unless otherwise specified.

Parameters	Symbol	Conditions	Min	Typ	Max	Unit
Input Voltage	$V_{IN}$		2.5		5.5	V
Quiescent Current	$I_Q$	$V_{FB}=0.65V$		62	100	$\mu A$
Shutdown Supply Current	$I_{STBY}$	$V_{EN}=GND$		0.1	1	$\mu A$
Reference Voltage	$V_{REF}$		0.588	0.6	0.612	V
Feedback Bias Current	$I_{FB\_H}$	$V_{FB}=1V$	-0.1		0.1	$\mu A$
	$I_{FB\_L}$	$V_{FB}=0V$	-0.1		0.1	
PMOSFET $R_{ON}$	$R_{DS(ON)\_P}$	$I_{SW}=200mA$		0.25		$\Omega$
NMOSFET $R_{ON}$	$R_{DS(ON)\_N}$	$I_{SW}=-200mA$		0.2		$\Omega$
Switch Current Limit	$I_{LIM}$	$V_{FB}=0.55V$	1.5	2.0		A
EN Pin Threshold	$V_H$		1.5			V
	$V_L$				0.4	
UVLO Threshold	$V_{UVLO}$	$V_{IN}$ Rising		2.3		V
UVLO Hysteresis	$V_{HYS}$			0.2		
Oscillator Frequency	$f_{OSC}$		1.12	1.40	1.68	MHz
Max. Duty Cycle	$D_{MAX}$		100			%
Min. Duty Cycle	$D_{MIN}$				0	
SW Leakage Current	$I_{SW\_H}$	$V_{SW}=0V$		0.1		$\mu A$
	$I_{SW\_L}$	$V_{SW}=5V$		0.1		
Soft-start Time	$t_{SS}$			1		ms
Thermal Shutdown	$T_{OTSD}$			160		$^{\circ}C$
Thermal Shutdown Hysteresis	$T_{HYS}$			20		$^{\circ}C$
Input OVP Threshold	$V_{IOVP}$	$V_{IN}$ Rising		6.3		V
Input OVP Hysteresis	$V_{IOVP\_HYS}$			0.5		V

**1.2A, 1.4MHz High Efficiency Synchronous DC-DC Buck Converter AP3417B**

**Typical Performance Characteristics**

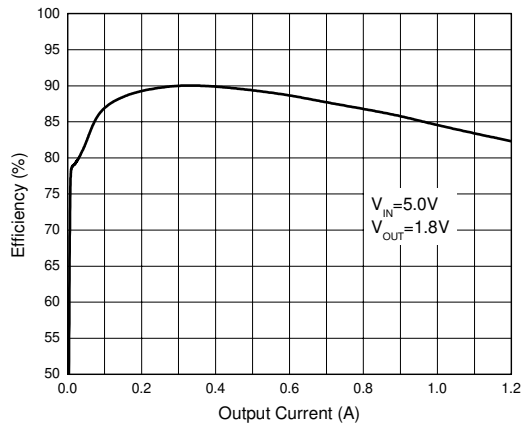

Figure 4. Efficiency vs. Output Current

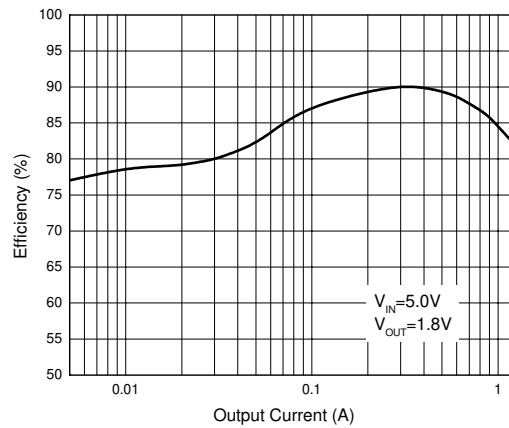

Figure 5. Efficiency vs. Output Current

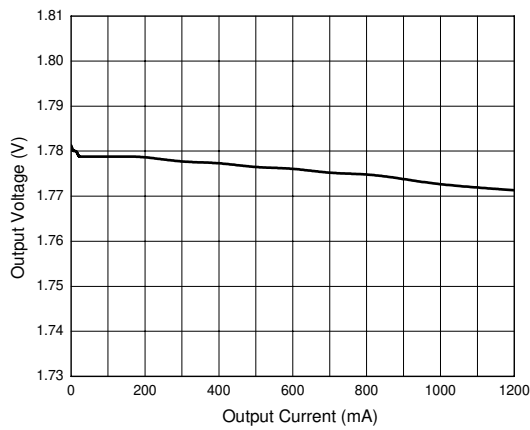

Figure 6. Output Voltage vs. Output Current

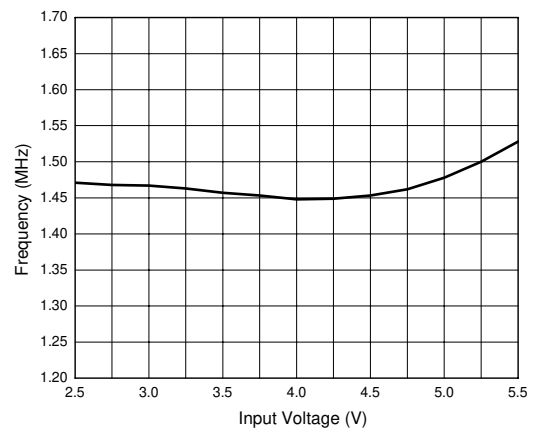

Figure 7. Frequency vs. Input Voltage

**1.2A, 1.4MHz High Efficiency Synchronous DC-DC Buck Converter AP3417B**

**Typical Performance Characteristics (Continued)**

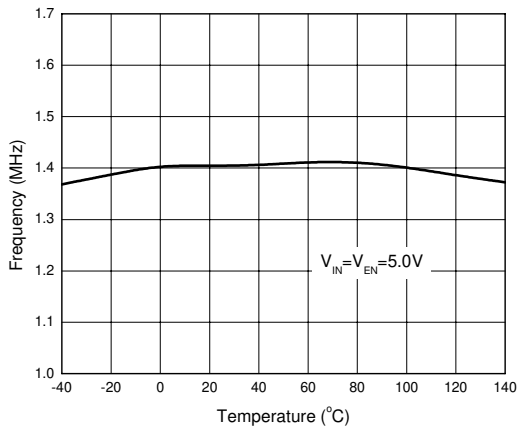

Figure 8. Frequency vs. Temperature

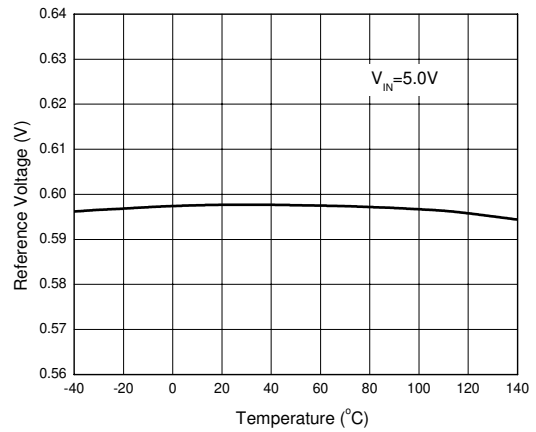

Figure 9. Reference Voltage vs. Temperature

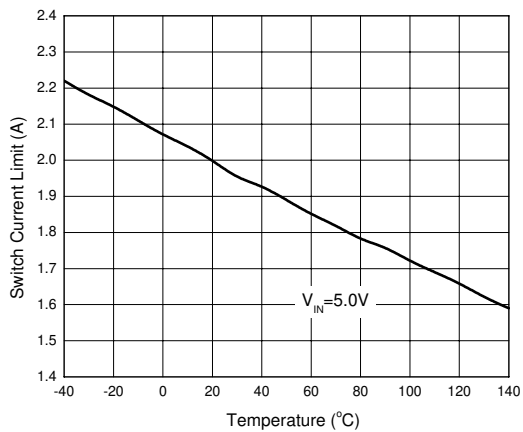

Figure 10. Switch Current Limit vs. Temperature

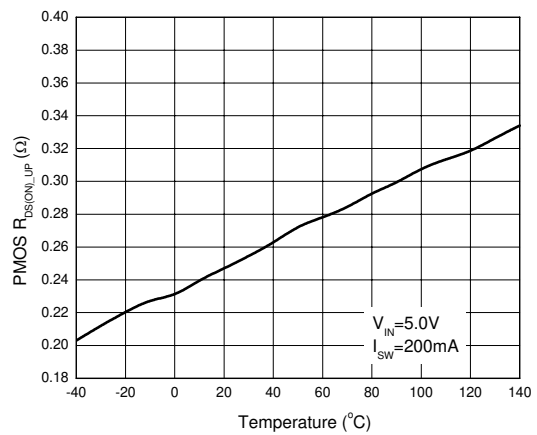

Figure 11. R\_DS(ON)\_UP vs. Temperature

**1.2A, 1.4MHz High Efficiency Synchronous DC-DC Buck Converter AP3417B**

**Typical Performance Characteristics (Continued)**

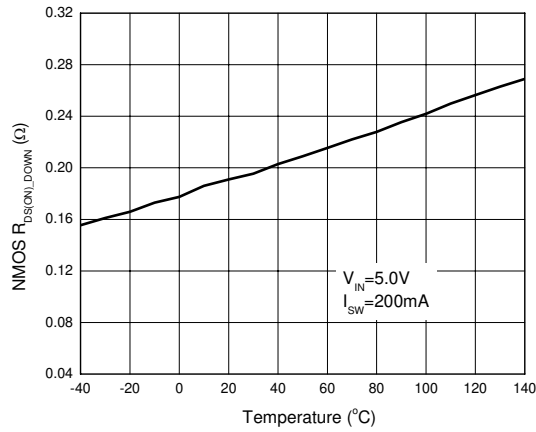

Figure 12.  $R_{DS(ON)_DOWN}$  vs. Temperature

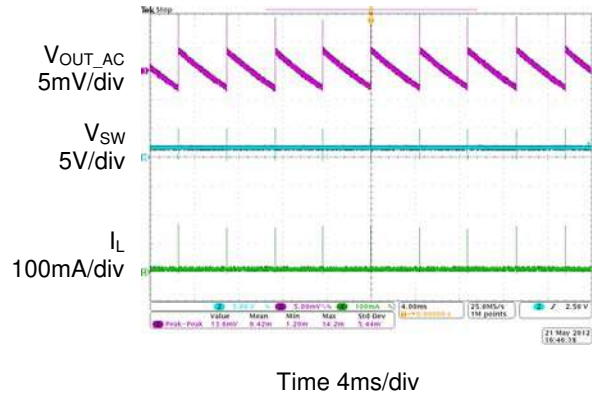

Figure 13. Output Ripple ( $I_{OUT}=0A$ )

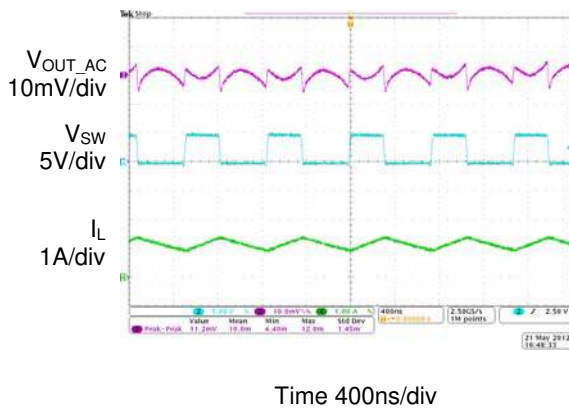

Figure 14. Output Ripple ( $I_{OUT}=1.2A$ )

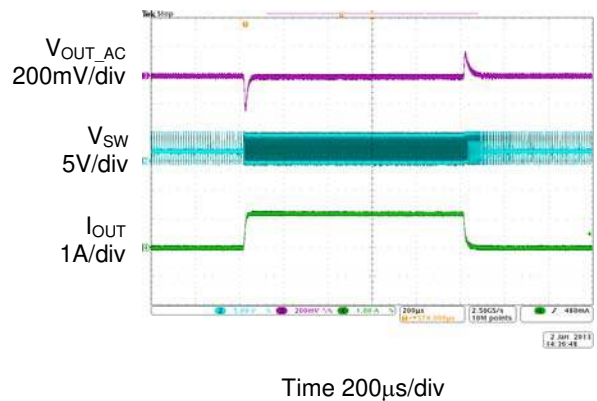
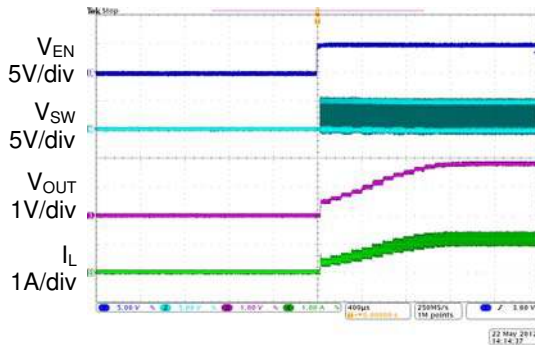

Figure 15. Load Transient ( $I_{OUT}=0A$  to  $1.2A$ )



**1.2A, 1.4MHz High Efficiency Synchronous DC-DC Buck Converter AP3417B**

**Typical Performance Characteristics (Continued)**



Time 400µs/div

Figure 16. Enable Turn On ( $I_{OUT}=1.2A$ )

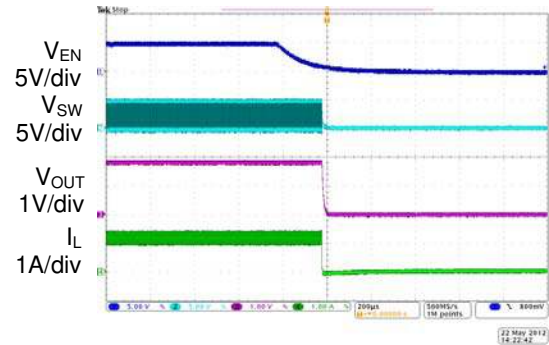

Time 200µs/div

Figure 17. Enable Turn Off ( $I_{OUT}=1.2A$ )

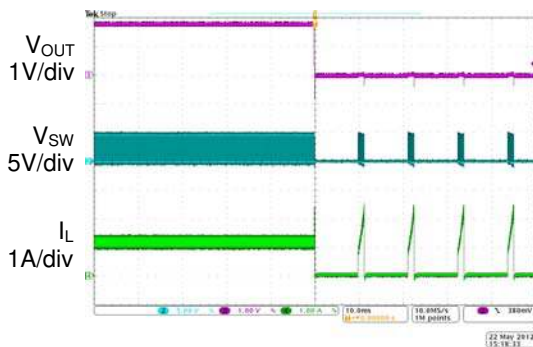

Time 10ms/div

Figure 18. Short Circuit Protection ( $I_{OUT}=1.2A$ )

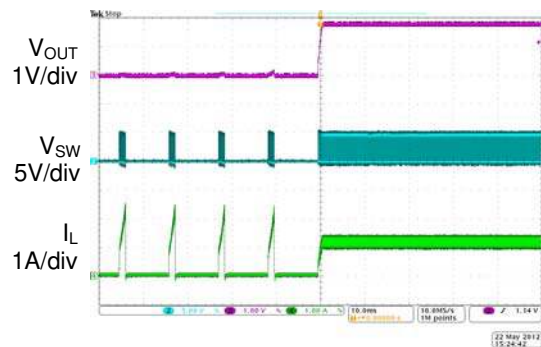

Time 10ms/div

Figure 19. Short Circuit Protection Recovery ( $I_{OUT}=1.2A$ )

**1.2A, 1.4MHz High Efficiency Synchronous DC-DC Buck Converter AP3417B**

**Typical Performance Characteristics (Continued)**

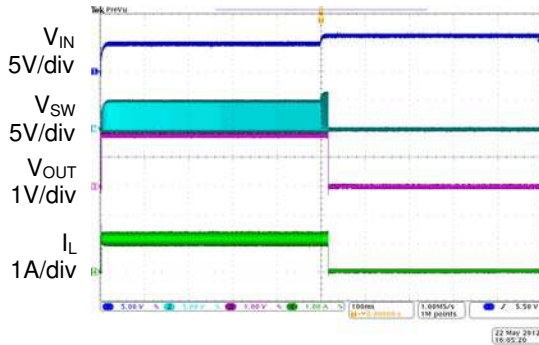

Time 100ms/div

Figure 20. Over Voltage Protection  
( $I_{OUT}=1.2A$ )

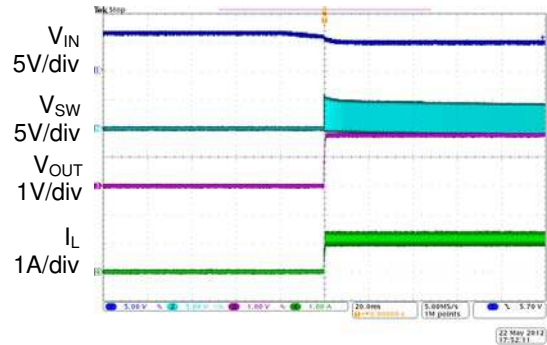

Time 20ms/div

Figure 21. Over Voltage Protection Recovery  
( $I_{OUT}=1.2A$ )

**1.2A, 1.4MHz High Efficiency Synchronous DC-DC Buck Converter AP3417B**

**Typical Application**

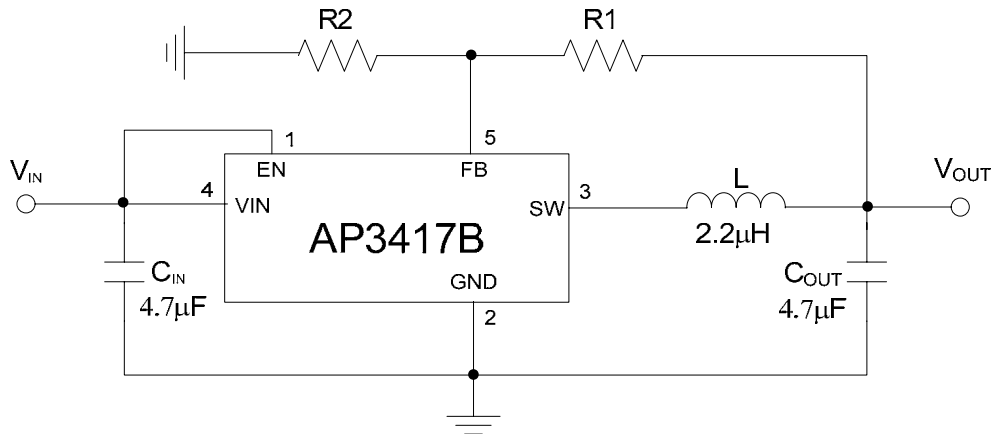

Figure 22. Typical Application of AP3417B





## **BCD Semiconductor Manufacturing Limited**

<http://www.bcdsemi.com>

### **IMPORTANT NOTICE**

BCD Semiconductor Manufacturing Limited reserves the right to make changes without further notice to any products or specifications herein. BCD Semiconductor Manufacturing Limited does not assume any responsibility for use of any its products for any particular purpose, nor does BCD Semiconductor Manufacturing Limited assume any liability arising out of the application or use of any its products or circuits. BCD Semiconductor Manufacturing Limited does not convey any license under its patent rights or other rights nor the rights of others.

---

#### **MAIN SITE**

##### **- Headquarters**

##### **BCD Semiconductor Manufacturing Limited**

No. 1600, Zi Xing Road, Shanghai Zizhu Science-based Industrial Park, 200241, China  
Tel: +86-21-24162266, Fax: +86-21-24162277

##### **- Wafer Fab**

##### **Shanghai SIM-BCD Semiconductor Manufacturing Co., Ltd.**

800 Yi Shan Road, Shanghai 200233, China  
Tel: +86-21-6485 1491, Fax: +86-21-5450 0008

#### **REGIONAL SALES OFFICE**

##### **Shenzhen Office**

##### **Shanghai SIM-BCD Semiconductor Manufacturing Co., Ltd., Shenzhen Office**

Unit A Room 1203, Skyworth Bldg., Gaoxin Ave. 1.S., Nanshan District, Shenzhen, China  
Tel: +86-755-8826 7951  
Fax: +86-755-8826 7865

##### **Taiwan Office**

##### **BCD Semiconductor (Taiwan) Company Limited**

4F, 298-1, Rui Guang Road, Nei-Hu District, Taipei, Taiwan  
Tel: +886-2-2656 2808  
Fax: +886-2-2656 2806

##### **USA Office**

##### **BCD Semiconductor Corp.**

30920 Huntwood Ave. Hayward, CA 94544, USA  
Tel : +1-510-324-2988  
Fax: +1-510-324-2788