



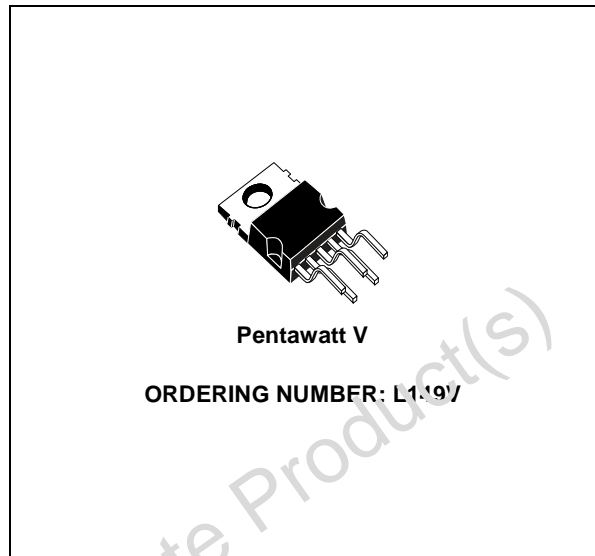
4A LINEAR DRIVER

- HIGH OUTPUT CURRENT (4A peak)
- HIGH CURRENT GAIN (10.000 typ.)
- OPERATION UP TO ± 20 V
- THERMAL PROTECTION
- SHORT CIRCUIT PROTECTION
- OPERATION WITHIN SOA
- HIGH SLEW-RATE (30 V/ms)

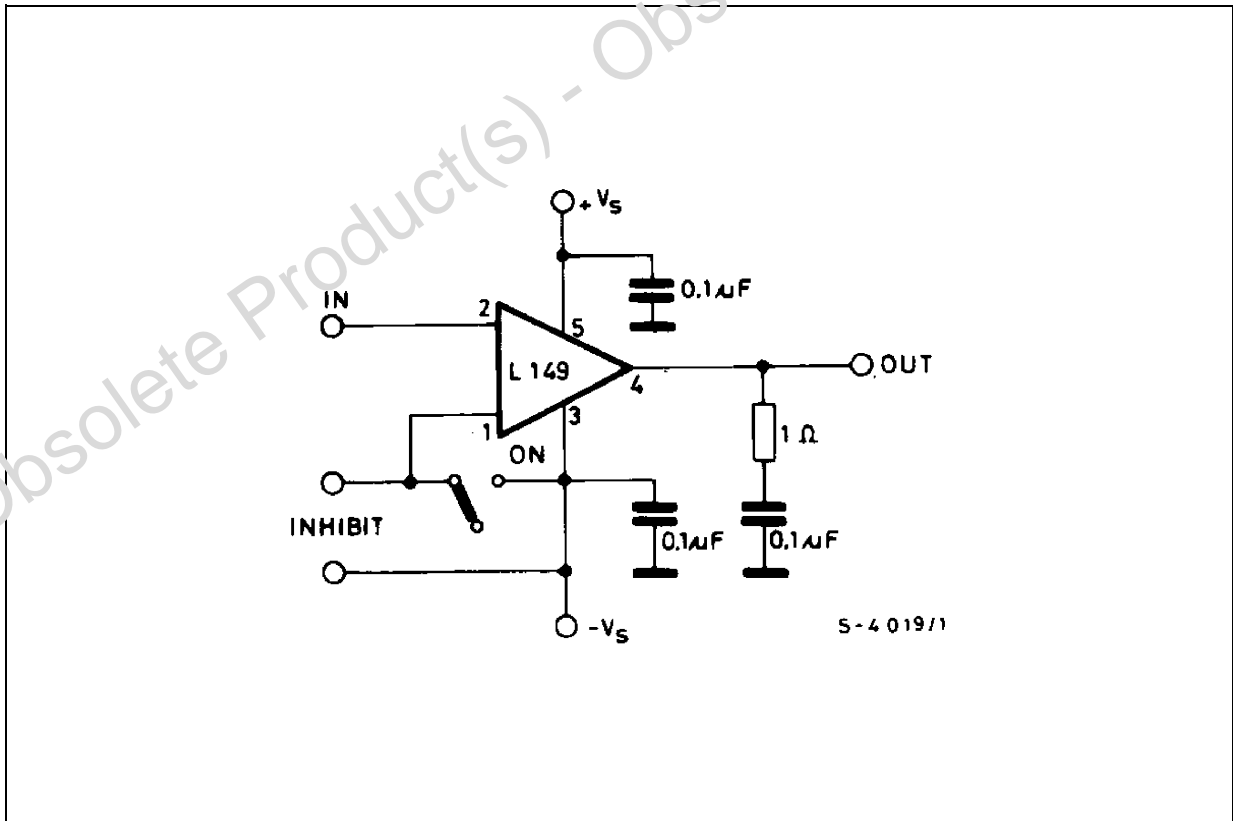
DESCRIPTION

The L149 is a general purpose power booster in Pentawatt [®] package consisting of a quasi-complementary darlington output stage with the associated biasing system an inhibit facility.

The device is particularly suited for use with an operational amplifier inside a closed loop configuration to increase output current.



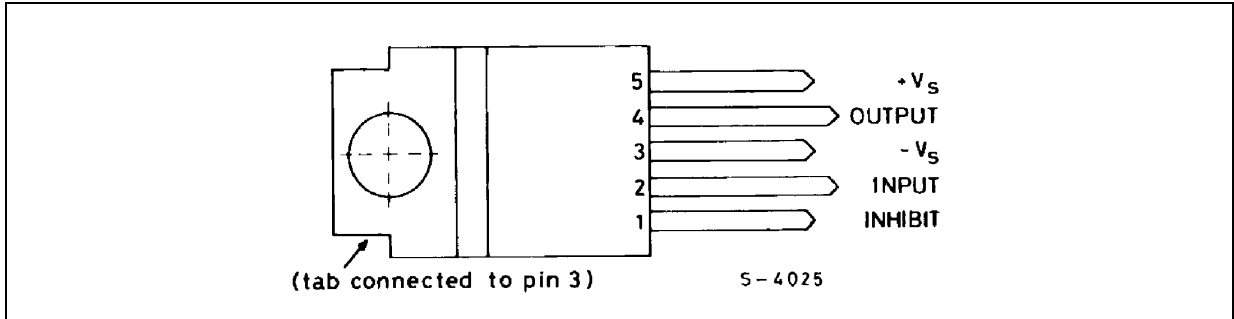
TEST CIRCUIT



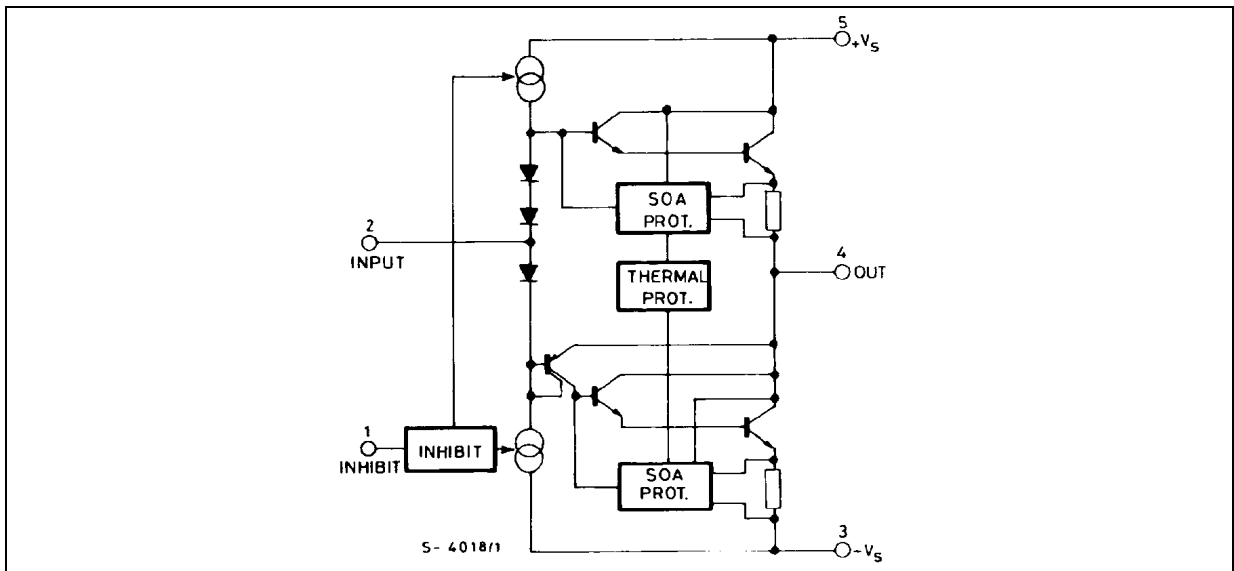
ABSOLUTE MAXIMUM RATINGS

Symbol	Parameter	Value	Unit
V_S	Supply Voltage	± 20	V
V_i	Input Voltage		V_S
$V_5 - V_4$	Upper Power Transistor V_{CE}	40	V
$V_4 - V_3$	Lower Power Transistor V_{CE}	40	V
I_O	DC Output Current	3	A
I_O	Peak Output Current (internally limited)	4	A
V_{INH}	Input Inhibit Voltage	$-V_S + 5$	V
		$-V_S - 1.5$	V
P_{tot}	Total Power Dissipation at $T_{case} = 75\text{ }^\circ\text{C}$)	25	W

PIN CONNECTION (Top view)



SCHEMATIC DIAGRAM



THERMAL DATA

Symbol	Parameter	Value	Unit
$R_{th-j-case}$	Thermal resistance junction-case	max 3	$^\circ\text{C/W}$

ELECTRICAL CHARACTERISTICS ($T_j = 25\text{ }^\circ\text{C}$, $V_S = \pm 16\text{V}$)

Symbol	Parameter	Test Condition	Min.	Typ.	Max.	Unit
V_S	Supply Voltage				± 20	V
I_d	Quiescent Drain Current	$V_S = \pm 16\text{V}$		30		mA
I_{in}	Input current	$V_S = \pm 16\text{V}$; $V_i = 0\text{V}$		200	400	μA
h_{FE}	DC current drain	$V_S = \pm 16\text{V}$; $I_O = 3\text{A}$	6000	10000		-
G_V	Voltage gain	$V_S = \pm 16\text{V}$; $I_O = 1.5\text{A}$		1		-
V_{CEsat}	Saturation voltage (for each transistor)	$I_O = 3\text{A}$			3.5	V
V_{OS}	Input offset voltage	$V_S = \pm 16\text{V}$			0.3	V
V_{INH}	Inhibit input voltage (pins 1-3)	ON condition			± 0.3	V
		OFF condition	± 1.8			V
R_{INH}	Inhibit input resistance			2.0		$\text{K}\Omega$
SR	Slew rate			30		$\text{V}/\mu\text{s}$
B	Power bandwidth	$V_O = \pm 10\text{V}$, $d = 1\%$, $R_L = 8\Omega$		200		KHz

APPLICATION INFORMATION

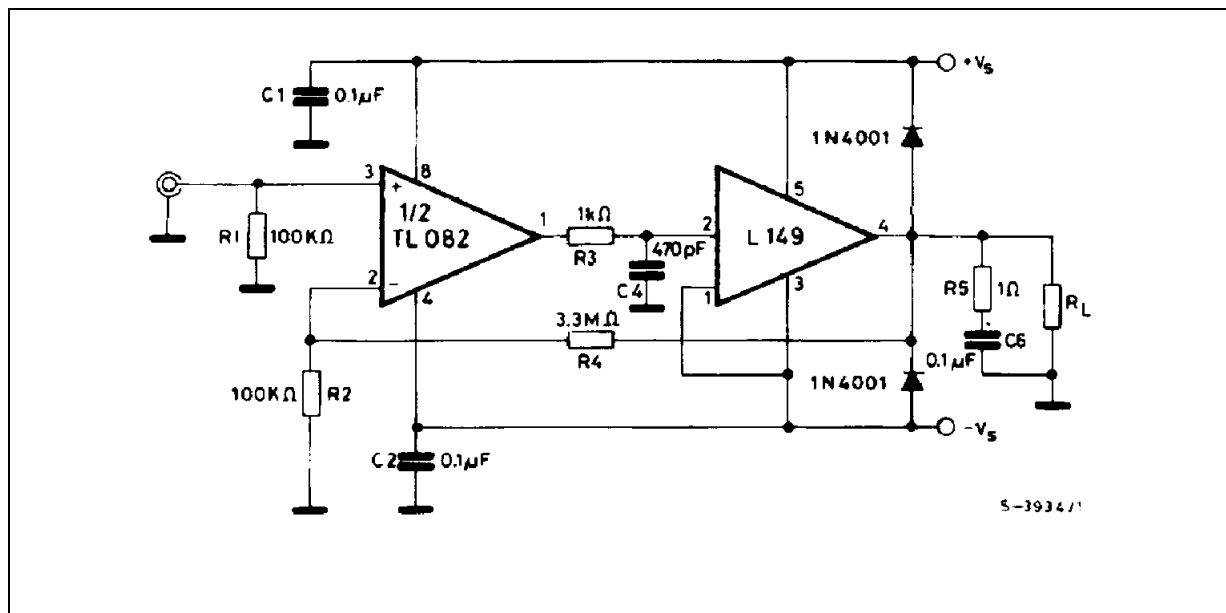
Figure 1. High slew-rate power operational amplifier ($\text{SR} = 13\text{V}/\mu\text{s}$)

Figure 2. Maximum saturation voltage vs. output current.

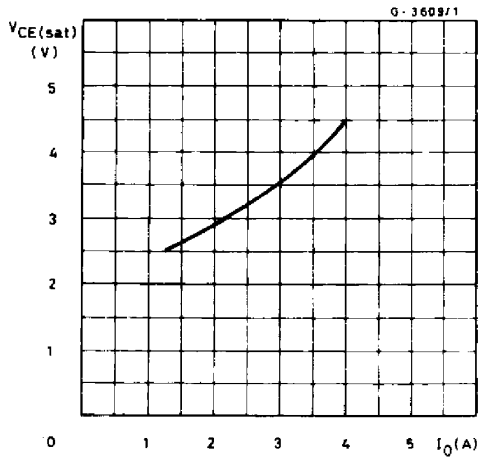


Figure 3. Current limiting characteristics.

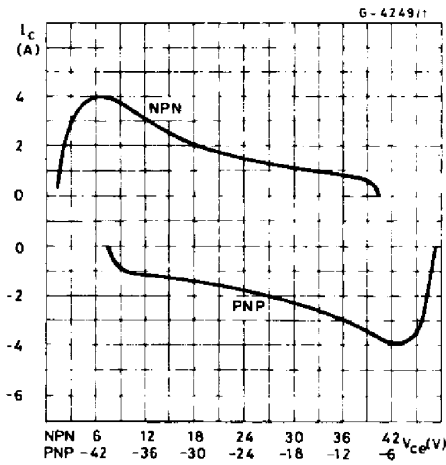


Figure 4. Supply voltage rejection vs. frequency.

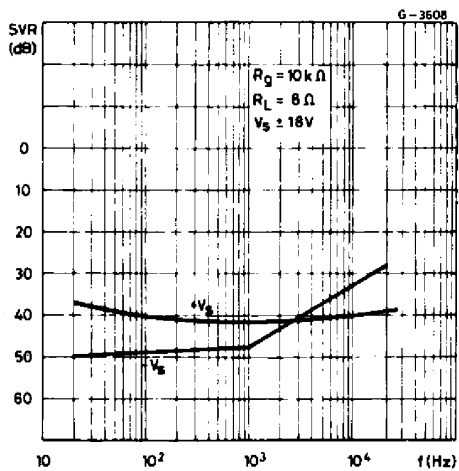


Figure 5. Distorsion vs. output power (f = 1KHz).

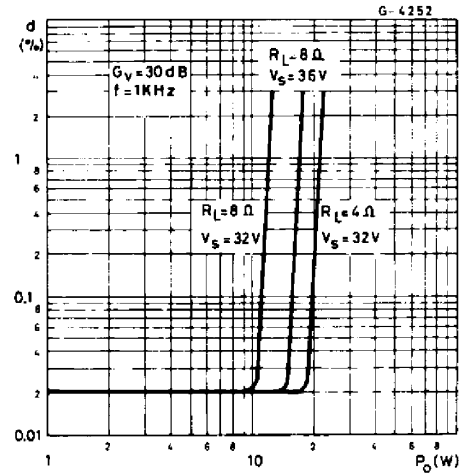


Figure 6. Distorsion vs. output power (f = 1KHz).

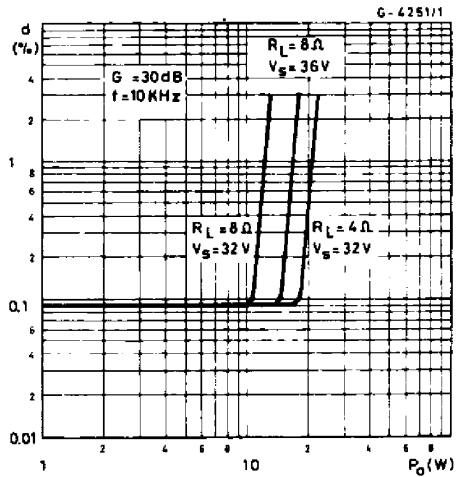
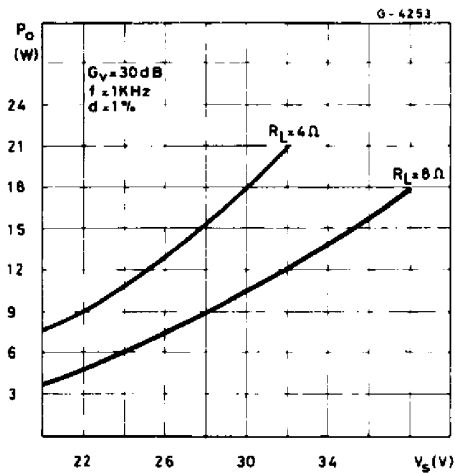


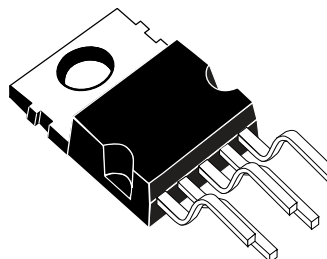
Figure 7. Output power vs. supply voltage.



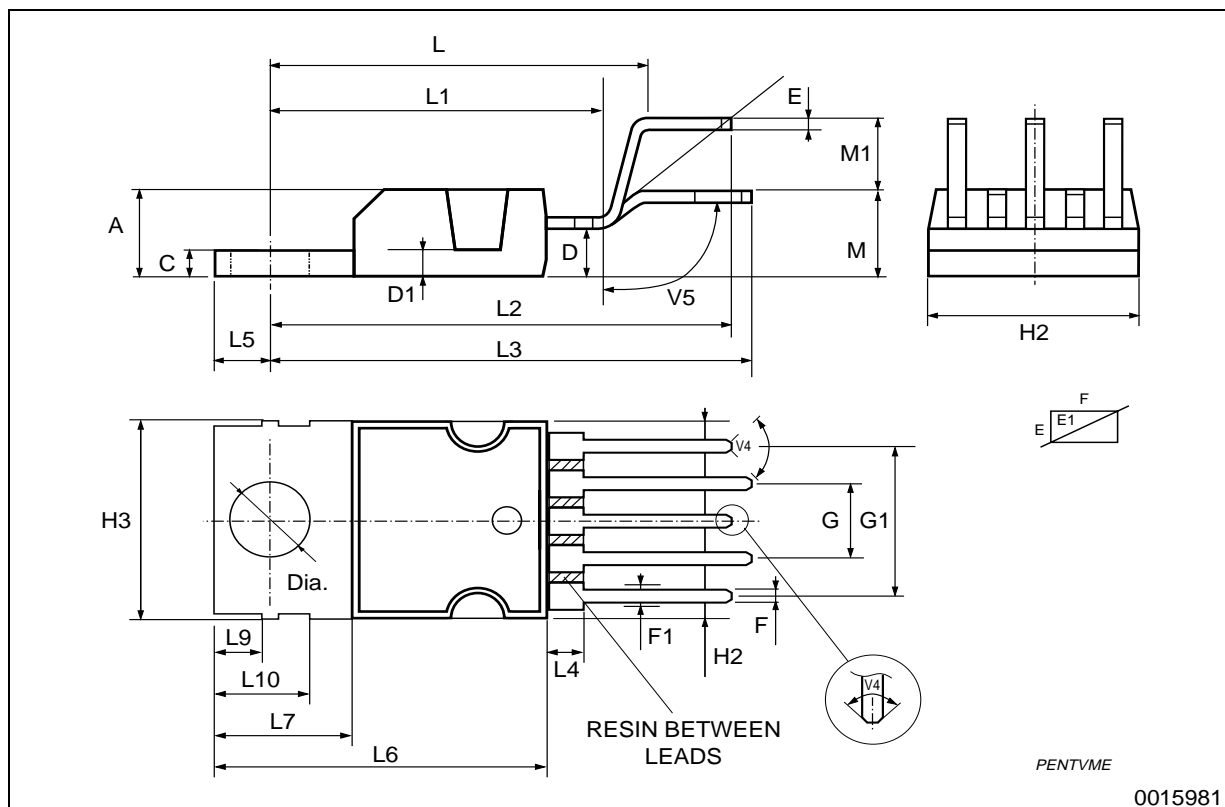
DIM.	mm			inch		
	MIN.	TYP.	MAX.	MIN.	TYP.	MAX.
A			4.8			0.189
C			1.37			0.054
D	2.4		2.8	0.094		0.110
D1	1.2		1.35	0.047		0.053
E	0.35		0.55	0.014		0.022
E1	0.76		1.19	0.030		0.047
F	0.8		1.05	0.031		0.041
F1	1.0		1.4	0.039		0.055
G	3.2	3.4	3.6	0.126	0.134	0.142
G1	6.6	6.8	7.0	0.260	0.268	0.276
H2			10.4			0.409
H3	10.05		10.4	0.396		0.409
L	17.55	17.85	18.15	0.691	0.703	0.715
L1	15.55	15.75	15.95	0.612	0.620	0.628
L2	21.2	21.4	21.6	0.831	0.843	0.850
L3	22.3	22.5	22.7	0.878	0.886	0.894
L4			1.29			0.051
L5	2.6		3.0	0.102		0.118
L6	15.1		15.8	0.594		0.622
L7	6.0		6.6	0.236		0.260
L9	2.1		2.7	0.008		0.106
L10	4.3		4.8	0.17		0.189
M	4.23	4.5	4.75	0.167	0.178	0.187
M1	3.75	4.0	4.25	0.148	0.157	0.167
V4	40° (typ.)					
V5	90° (typ.)					
Dia	3.65		3.85	0.144		0.152

OUTLINE AND MECHANICAL DATA

Weight: 2.00gr



Pentawatt V



Information furnished is believed to be accurate and reliable. However, STMicroelectronics assumes no responsibility for the consequences of use of such information nor for any infringement of patents or other rights of third parties which may result from its use. No license is granted by implication or otherwise under any patent or patent rights of STMicroelectronics. Specifications mentioned in this publication are subject to change without notice. This publication supersedes and replaces all information previously supplied. STMicroelectronics products are not authorized for use as critical components in life support devices or systems without express written approval of STMicroelectronics.

STMicroelectronics acknowledges the trademarks of all companies referred to in this document.

The ST logo is a registered trademark of STMicroelectronics
© 2003 STMicroelectronics - All Rights Reserved

STMicroelectronics GROUP OF COMPANIES
Australia - Brazil - Canada - China - Finland - France - Germany - Hong Kong - India - Israel - Italy - Japan - Malaysia - Malta - Morocco -
Singapore - Spain - Sweden - Switzerland - United Kingdom - United States.
<http://www.st.com>