

PC Power Supply Supervisors

SG6520

FEATURES

- Two 12V sense input pins: VS12 and VS12B
- Over voltage protection (OVP) for 3.3V, 5V, and two 12V
- Over current protection (OCP) for 3.3V, 5V, and two 12V
- Under voltage protection (UVP) for 3.3V, 5V, and two 12V
- Open drain output for PGO and FPO pins
- 300mS power good delay
- 300mS turn on delay for 3.3V, 5V and two 12V
- 2.8mS PSON control to FPO turn-off delay
- 48mS PSON control delay
- No lockup during the fast AC power on/off
- Wide supply voltage range from 4.2V to 15V
- Programmable over temperature protection(OTP)

DESCRIPTION

SG6520 is designed to provide the voltage, and current supervisor function, remote on/off (PSON) function,

power good (PGO) indicator function, and fault protection (FPO) function for switching power systems.

For supervisor function, it provides the over voltage protection (OVP) for 3.3V, 5V and two 12V; over current protection (OCP) for 3.3V, 5V and two 12V; under voltage protection (UVP) for 3.3V, 5V and two 12V. When 3.3V, 5V or 12V voltage is decreasing to 2.3V, 3.5V and 9V respectively, the under voltage protection (UVP) function will be enabled. FPO will be set to high to turn off the PWM controller IC. The voltage difference across external current shunt is used for OCP functions. An external resistor can be used to adjust protection threshold.

The power supply is turned on after 48mS delay time when PSON signal is set from high to low. To turn off power supply, PSON signal is set from low to high with the delay time 48mS. The PGI circuitry provides a power-down warning signal for PGO. When PGI input is lower than the internal 1.25V reference voltage, PGO signal is pulled low.

TYPICAL APPLICATION

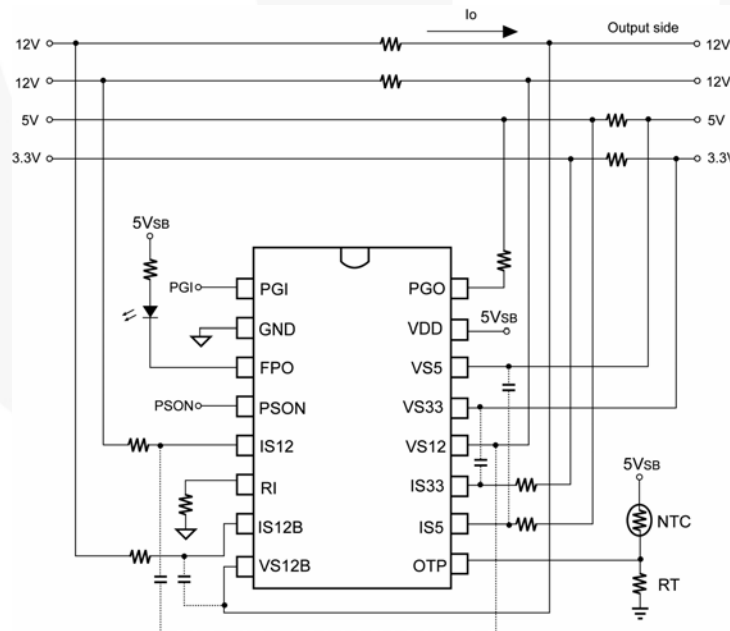

MARKING INFORMATION



T: D = DIP, S = SOP  
 P: Z = Lead Free  
 Null=regular package  
 XXXXXXXX: Wafer Lot  
 Y: Year; WW: Week  
 V: Assembly Location

PIN CONFIGURATION

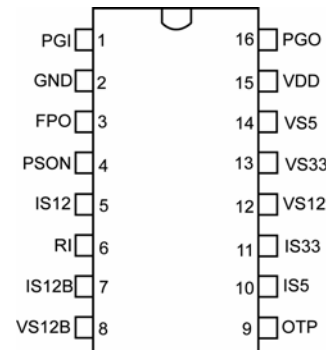

ORDERING INFORMATION

Part Number	Pb-Free	Package Type
SG6520DZ		16 pin DIP Plastic
SG6520SZ (Preliminary)		16 pin SOP Plastic

PIN DESCRIPTIONS

Pin No.	Pin Name	Type	Description
1	PGI	Analog input	Power Good Input. For ATX SMPS, it detects AC line voltage through the main transformer.
2	GND	Supply	Ground.
3	FPO	Logic output	Fault Protection Output. Output signal to control the primary PWM IC through an opto-coupler. When FPO is low, the PWM IC is enabled.
4	PSON	Logic input	Remote On/Off logic input from CPU or main-board. The power supply will be turned on/off after 48mS delay.
5	IS12	Analog input	12V over current protection sense input. For typical application, this pin is connected to the positive end of a current shunt through one resistor. When the voltage on IS12 is higher than that of VS12 by 5mV, OCP will be enabled.
6	RI	Analog input	Reference setting. One external resistor Ri connected between RI and GND pin will determine a reference current, Iref = 1.25/Ri, for OCP programming.
7	IS12B	Analog input	12V over current protection sense input. For typical application, this pin is connected to the positive end of a current shunt through one resistor. When the voltage on IS12 is higher than that of VS12 by 5mV, OCP will be enabled.
8	VS12B	Analog input	Second 12V over/under-voltage control sense input.
9	OTP	Analog input	For over-temperature protection.
10	IS5	Analog input	5V over current protection sense input.
11	IS33	Analog input	3.3V over current protection sense input.
12	VS12	Analog input	12V over/under-voltage control sense input.
13	VS33	Analog input	3.3V over/under-voltage control sense input.
14	VS5	Analog input	5V over/under-voltage control sense input.
15	VDD	Supply	Supply voltage. 4.2V ~ 15V. For ATX SMPS, it is connected to 5V-standby and 12V through diodes respectively.
16	PGO	Logic output	Power good logic output, 0 or 1(open-drain). Power good=1 means that the power supply is good for operation. The power good delay is 300mS.

BLOCK DIAGRAM

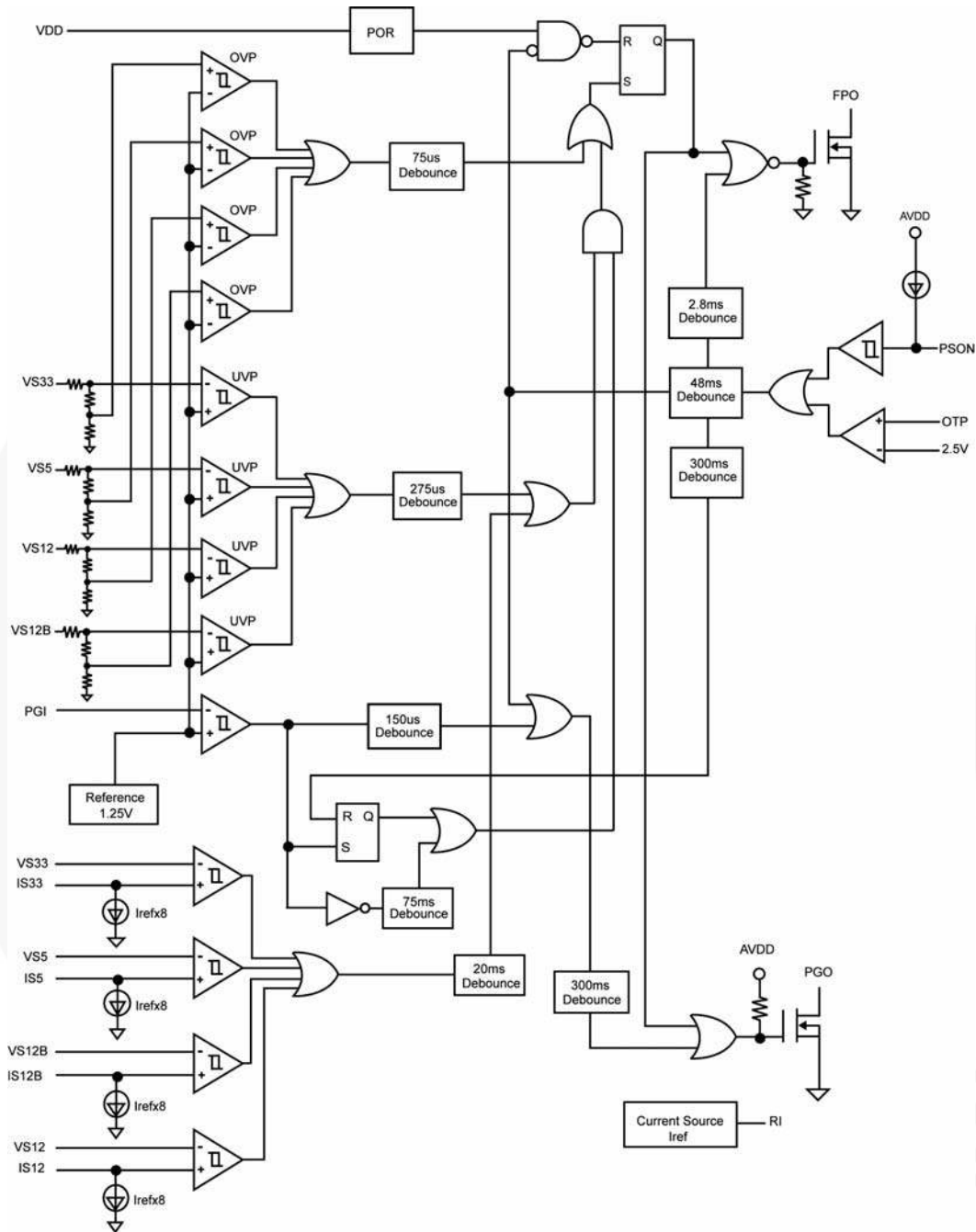

**FUNCTION TABLE**

PGI	PERSON	UV Protection 12V & OC Protection	OV Protection	FPO	PGO
PGI<1.25V	L	No	No	L	L
PGI<1.25V	L	No	Yes	H	L
PGI<1.25V	L	Yes	No	L	L
PGI<1.25V	L	Yes	Yes	H	L
PGI>1.25V	L	No	No	L	H
PGI>1.25V	L	No	Yes	H	L
PGI>1.25V	L	Yes	No	H	L
PGI>1.25V	L	Yes	Yes	H	L
X	H	X	X	H	L

x = don't care

FPO = L means: fault IS NOT latched

FPO = H means: fault IS latched

PGO = L means: fault

PGO = H means: No fault

**TIMING DIAGRAM**

**PSON On/Off and 3.3V, 5V OVP Function**

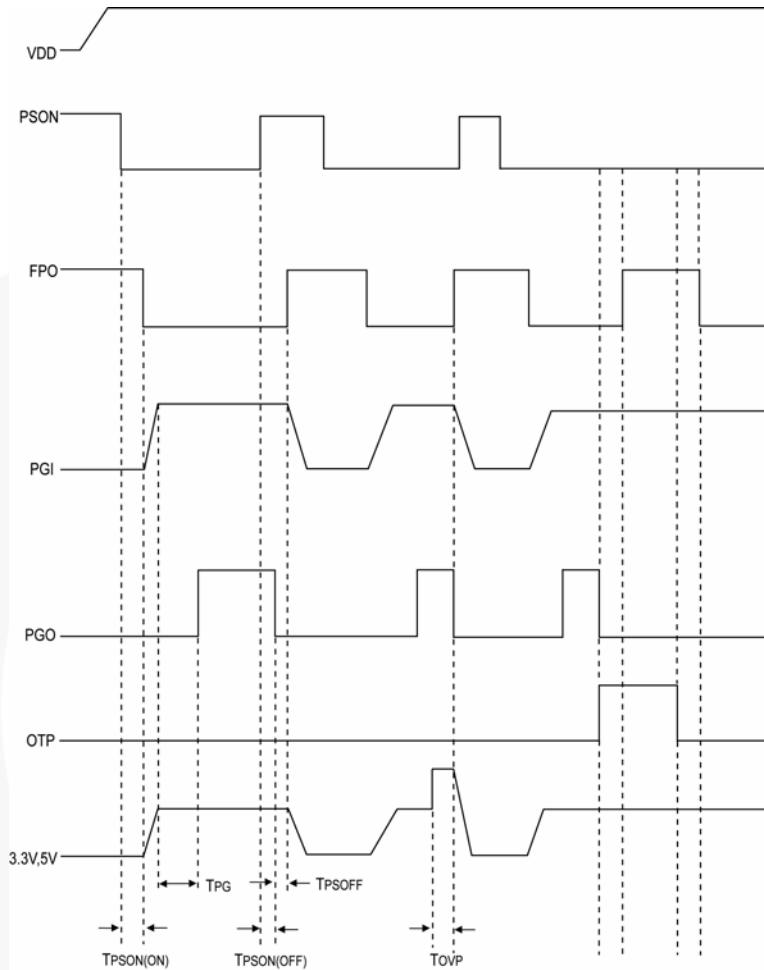

12V OVP/UVP and OCP Function

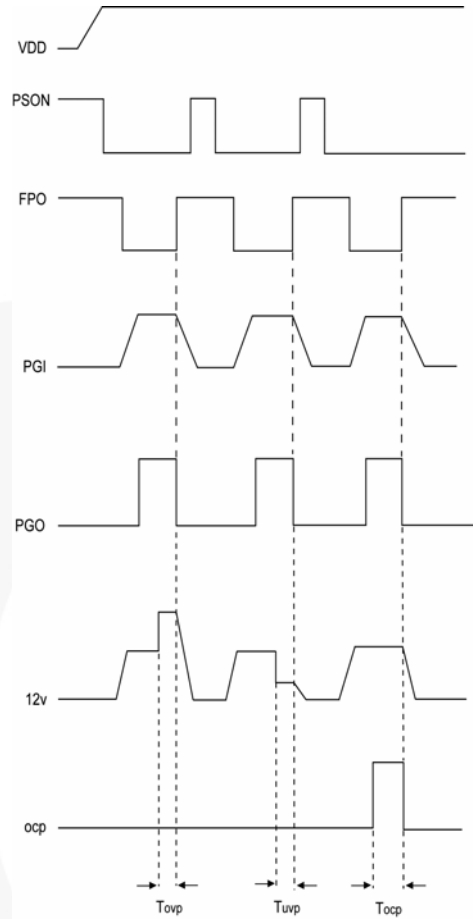

**ABSOLUTE MAXIMUM RATINGS**

Symbol	Parameter	Value	Unit
V <sub>DD</sub>	DC Supply Voltage	16	V
V <sub>I</sub>	Input Voltage	PERSON, VS33, VS5, PGI, IS33, IS5, OTP	-0.3 to 7
	Input Voltage	VS12, VS12B, IS12, IS12B	-0.3 to 15
V <sub>OUT</sub>	Output Voltage	FPO, PGO	8
T <sub>J</sub>	Operating Junction Temperature	-40 to 125	°C
T <sub>STG</sub>	Storage Temperature Range	-55 to 150	°C
T <sub>L</sub>	Lead Temperature (Wave soldering or IR, 10 seconds)	260	°C
	ESD Capability, HBM Model	4.5	KV
	ESD Capability, Machine Model	200	V

\*All voltage values, except differential voltages, are given with respect to GND pin.

\* Stresses beyond those listed under "absolute maximum ratings" may cause permanent damage to the device.

**RECOMMENDED OPERATING CONDITIONS**

Symbol	Parameter	Test Conditions	Value	Unit
V <sub>DD</sub>	DC Supply Voltage		4.2 to 15	V
T <sub>OPER</sub>	Operating Ambient Temperature Range		-25 to +85	°C

\* For proper operation

**ELECTRICAL CHARACTERISTICS (V<sub>DD</sub>=12V, T<sub>A</sub>=25°C, UNLESS NOTED)**
**VDD Section**

Symbol	Parameter	Test Conditions	Min.	Typ.	Max.	Unit
I <sub>DD1</sub>	Supply Current	PERSON = Low		1.7	2.6	mA
I <sub>DD2</sub>	Supply Current	PERSON = High		1.0	1.5	mA
T <sub>R</sub>	Supply Voltage Rising Time		1			mS
V <sub>ST</sub>	VDD Start Threshold Voltage				4.2	V

**Over Voltage and Over Current Protection**

Symbol	Parameter	Test Conditions	Min.	Typ.	Max.	Unit
V <sub>OV</sub>	Over Voltage Protection VS33		3.7	3.9	4.1	V
	Over Voltage Protection VS5		5.7	6.1	6.5	
	Over Voltage Protection VS12, VS12B		13.2	13.8	14.4	
I <sub>REF</sub>	Ratio of current sense sink current to current sense setting pin (RI) source current	RI = 30 KΩ, 0.1% Resistor	7.6	8	8.4	
V <sub>OFFSET</sub>	OCP comparator input offset voltage		-5		5	mV
I <sub>LKG</sub>	Leakage Current (FPO)	V(FPO) = 5V			5	uA
V <sub>OL</sub>	Low Level Output Voltage (FPO)	Isink 20mA			0.4	V
T <sub>OV</sub>	OVP Delay Time		33	75	110	uS
T <sub>OCP</sub>	OCP Delay Time		12.5	20	27.5	mS
V <sub>RI</sub>	RI Pin Voltage		1.237	1.25	1.262	V
I <sub>RI</sub>	Output Current RI		12.5		62.5	uA
T <sub>ST-OCP</sub>	Start-up OCP / UVP Protection Time From FPO Low to FPO High	PGI < 1.25V, FPO=Low	200	300	450	mS

PC Power Supply Supervisors

SG6520

Under Voltage Protection and PGI, PGO

Symbol	Parameter	Test Conditions	Min.	Typ.	Max.	Unit
V <sub>PGI</sub>	Input Threshold Voltage PGI		1.225	1.25	1.275	V
V <sub>UVP</sub>	Under Voltage Protection VS33		2.1	2.3	2.5	V
	Under Voltage Protection VS5		3.3	3.5	3.7	
	Under Voltage Protection VS12, VS12B		8.5	9.0	9.5	
T <sub>OND</sub>	Under Voltage Turn-on Delay Time	PGI > 1.25V	49	75	114	mS
T <sub>UVP</sub>	UVP Delay Time	PGI > 1.25V	175	275	375	uS
I <sub>LKG-PGO</sub>	Leakage Current (PGO)	PGO = 5V			5	uA
V <sub>OL-PGO</sub>	Low Level Output Voltage (PGO)	VDD = 12V Isink 10Ma			0.4	V
T <sub>PG</sub>	Timing PG Delay	PGI to PGO	200	300	450	mS
T <sub>ND</sub>	Noise Deglitch Time	PGI to PGO	90	150	210	uS

PSON Control

Symbol	Parameter	Test Conditions	Min.	Typ.	Max.	Unit
I <sub>PSON</sub>	Input Pull-up Current	PSON = 0V		120		uA
V <sub>IH</sub>	High-level Input Voltage		2			V
V <sub>IL</sub>	Low-level Input Voltage				0.8	V
T <sub>PSON</sub>	Timing PSON to On/Off					mS
	On (PSON Low to FPO Low) Off (PSON High to PGO Low)		34 34	48 48	67 67	
T <sub>PSOFF</sub>	Timing PGO Low to FPO High		1.6	2.8	4.5	mS

Over Temperature Section

Symbol	Parameter	Test Conditions	Min.	Typ.	Max.	Unit
V <sub>TH</sub>	Over Temperature Threshold		2.4	2.5	2.6	V
V <sub>HYST</sub>	Hysteresis		0.18		0.23	V



TYPICAL CHARACTERISTICS

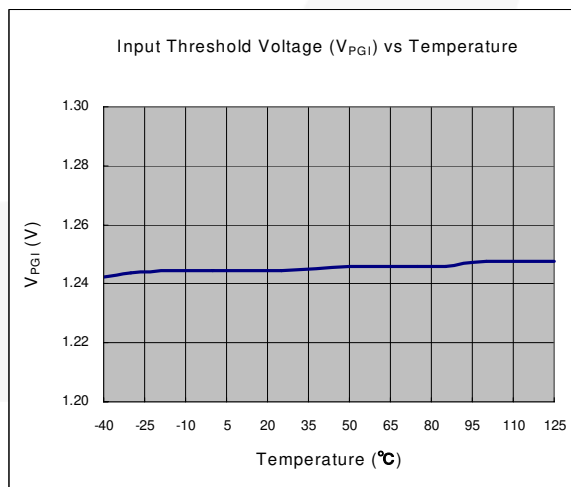
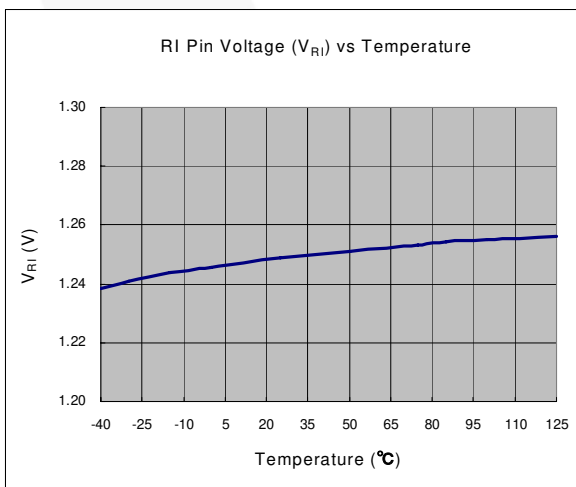
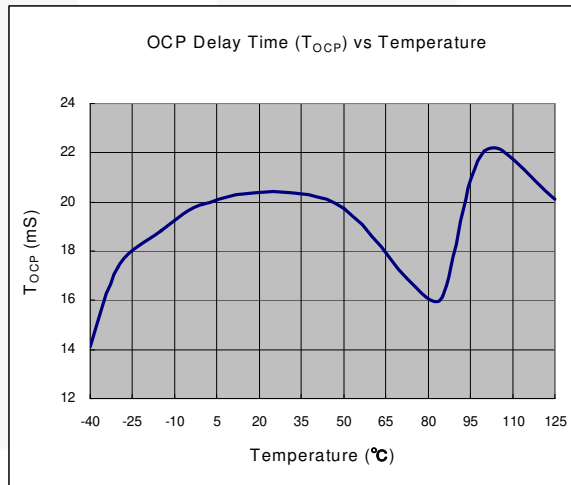
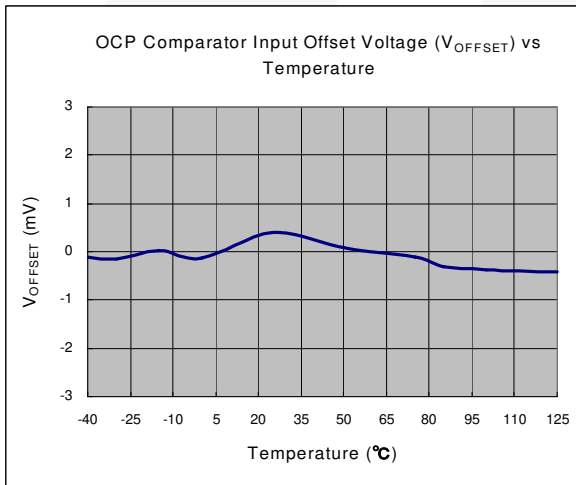
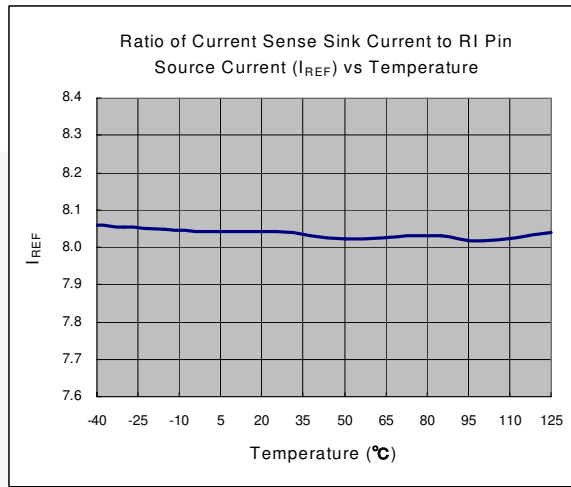
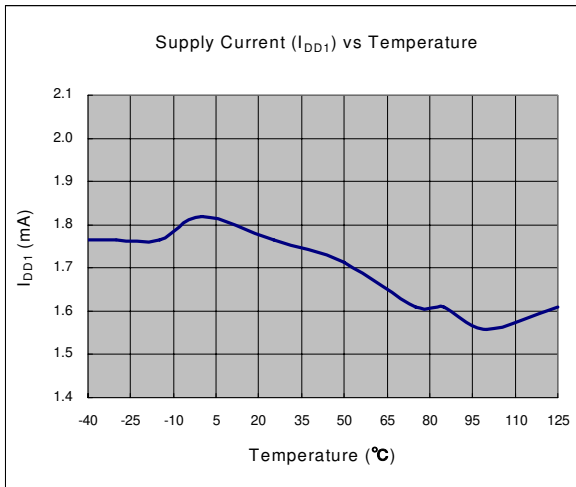

**APPLICATION NOTE**

**Over Current Protection (OCP)**

The SG6520 provides over current protection for the 3.3V, 5V and two 12V rails. Whenever an OCP condition occurs at any of the voltage rails, PGO will be low and FPO will be open. The internal OCP comparators have a very small offset voltage ( $\pm 5mV$ ).

The sink currents of IS33, IS5, IS12 and IS12B are 8 times the current at the RI pin. The current at the RI pin is  $V_{RI}/R_i$ . Here is an example demonstrating how to set the over current protection.

If  $I_1 * R_1 > (I_{RI} * 8) * R_2$ , then OCP active.

How to select R2 Resistor:

If  $R_1 = 5m\Omega$ ,  $R_i = 30K$ , OCP Protection Level is 35A, then

$$\begin{aligned}
 R_2 &= (I_1 * R_1) / (I_{RI} * 8) \\
 &= (35A * 5m\Omega) / \{(1.25V / 30K) * 8\} \\
 &= 525 \Omega
 \end{aligned}$$

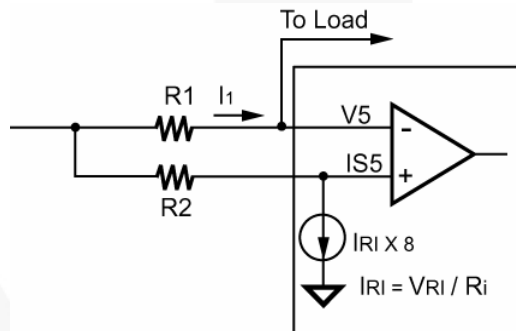

PACKAGE INFORMATION

16 PINS - DIP(D)

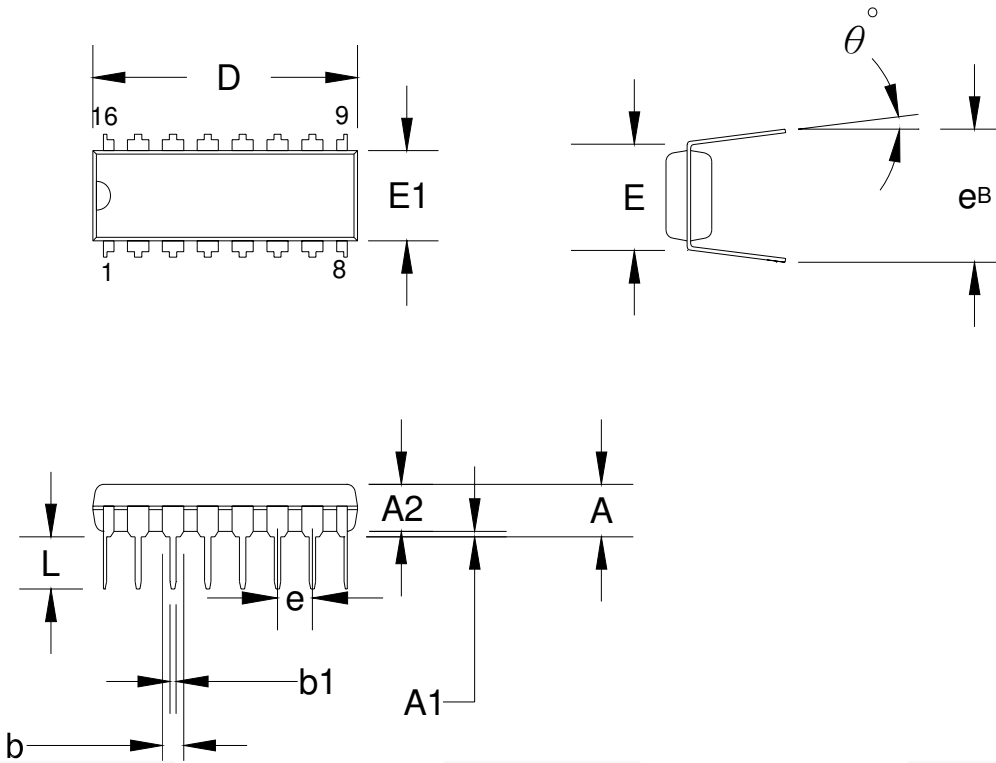

Dimensions:

Symbol	Millimeter			Inch		
	Min.	Typ.	Max.	Min.	Typ.	Max.
A			5.334			0.210
A1	0.381			0.015		
A2	3.175	3.302	3.429	0.125	0.130	0.135
b		1.524			0.060	
b1		0.457			0.018	
D	18.669	19.177	19.685	0.735	0.755	0.775
E		7.620			0.300	
E1	6.121	6.299	6.477	0.241	0.248	0.255
e		2.540			0.100	
L	2.921	3.302	3.810	0.115	0.130	0.150
eB	8.509	9.017	9.525	0.335	0.355	0.375
$\theta^\circ$	0°	7°	15°	0°	7°	15°

16 PINS - SOP(S)

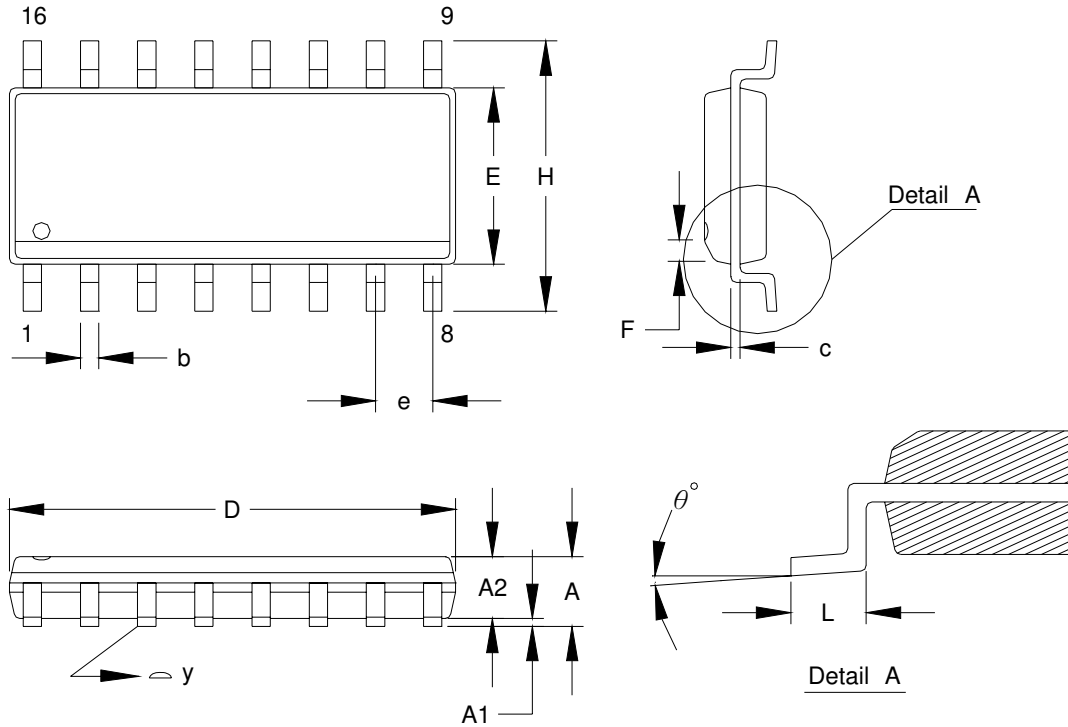

Dimension:

Symbol	Millimeter			Inch		
	Min.	Typ.	Max.	Min.	Typ.	Max.
A	1.346		1.753	0.053		0.069
A1	0.101		0.254	0.004		0.010
A2	1.244		1.499	0.049		0.059
b		0.406			0.016	
c		0.203			0.008	
D	9.804		10.008	0.386		0.394
E	3.810		3.988	0.150		0.157
e		1.270			0.050	
H	5.791		6.198	0.228		0.244
L	0.406		1.270	0.016		0.050
F		0.381X45°			0.015X45°	
y			0.101			0.004
$\theta^\circ$	0°		8°	0°		8°

PC Power Supply Supervisors

SG6520



TRADEMARKS

The following are registered and unregistered trademarks and service marks Fairchild Semiconductor owns or is authorized to use and is not intended to be an exhaustive list of all such trademarks.

- |                                      |  |  |                                  |
|--------------------------------------|--|--|----------------------------------|
| ACEx <sup>®</sup>                    | Green FPS <sup>™</sup>   | Power247 <sup>®</sup>                  | SuperSOT <sup>™</sup> -8         |
| Build it Now <sup>™</sup>            | Green FPS <sup>™</sup> e-Series <sup>™</sup>   | POWEREDGE <sup>®</sup>                 | SyncFET <sup>™</sup>             |
| CorePLUS <sup>™</sup>                | GTO <sup>™</sup>   | Power-SPM <sup>™</sup>                 | The Power Franchise <sup>®</sup> |
| CROSSVOL <sup>™</sup> ™              | i-Lo <sup>™</sup>  | PowerTrench <sup>®</sup>               | <b>the power franchise</b>       |
| CTL <sup>™</sup>                     | IntelliMAX <sup>™</sup>  | Programmable Active Droop <sup>™</sup> | TinyBoost <sup>™</sup>           |
| Current Transfer Logic <sup>™</sup>  | ISOPLANAR <sup>™</sup>   | QFET <sup>®</sup>                      | TinyBuck <sup>™</sup>            |
| EcoSPARK <sup>®</sup>                | MegaBuck <sup>™</sup>  | QS <sup>™</sup>                        | TinyLogic <sup>®</sup>           |
| <b>F<sup>®</sup></b>                 | MICROCOUPLER <sup>™</sup>  | QT Optoelectronics <sup>™</sup>        | TINYOPTO <sup>™</sup>            |
| Fairchild <sup>®</sup>               | MicroFET <sup>™</sup>  | Quiet Series <sup>™</sup>              | TinyPower <sup>™</sup>           |
| Fairchild Semiconductor <sup>®</sup> | MicroPak <sup>™</sup>  | RapidConfigure <sup>™</sup>            | TinyPWM <sup>™</sup>             |
| FACT Quiet Series <sup>™</sup>       | MillerDrive <sup>™</sup>   | SMART START <sup>™</sup>               | TinyWire <sup>™</sup>            |
| FACT <sup>®</sup>                    | Motion-SPM <sup>™</sup>  | SPM <sup>®</sup>                       | μSerDes <sup>™</sup>             |
| FAST <sup>®</sup>                    | OPTOLOGIC <sup>®</sup>   | STEALTH <sup>™</sup>                   | UHC <sup>®</sup>                 |
| FastvCore <sup>™</sup>               | OPTOPLANAR <sup>®</sup>  | SuperFET <sup>™</sup>                  | UniFET <sup>™</sup>              |
| FPS <sup>™</sup>                     |  <sup>®</sup> | SuperSOT <sup>™</sup> -3               | VCX <sup>™</sup>                 |
| FRFET <sup>®</sup>                   | PDP-SPM <sup>™</sup>   | SuperSOT <sup>™</sup> -6               |                                  |
| Global Power Resource <sup>SM</sup>  | Power220 <sup>®</sup>  |  |                                  |

DISCLAIMER

FAIRCHILD SEMICONDUCTOR RESERVES THE RIGHT TO MAKE CHANGES WITHOUT FURTHER NOTICE TO ANY PRODUCTS HEREIN TO IMPROVE RELIABILITY, FUNCTION, OR DESIGN. FAIRCHILD DOES NOT ASSUME ANY LIABILITY ARISING OUT OF THE APPLICATION OR USE OF ANY PRODUCT OR CIRCUIT DESCRIBED HEREIN; NEITHER DOES IT CONVEY ANY LICENSE UNDER ITS PATENT RIGHTS, NOR THE RIGHTS OF OTHERS. THESE SPECIFICATIONS DO NOT EXPAND THE TERMS OF FAIRCHILD'S WORLDWIDE TERMS AND CONDITIONS, SPECIFICALLY THE WARRANTY THEREIN, WHICH COVERS THESE PRODUCTS.

LIFE SUPPORT POLICY

FAIRCHILD'S PRODUCTS ARE NOT AUTHORIZED FOR USE AS CRITICAL COMPONENTS IN LIFE SUPPORT DEVICES OR SYSTEMS WITHOUT THE EXPRESS WRITTEN APPROVAL OF FAIRCHILD SEMICONDUCTOR CORPORATION.

As used herein:

- Life support devices or systems are devices or systems which, (a) are intended for surgical implant into the body or (b) support or sustain life, and (c) whose failure to perform when properly used in accordance with instructions for use provided in the labeling, can be reasonably expected to result in a significant injury of the user.
- A critical component in any component of a life support, device, or system whose failure to perform can be reasonably expected to cause the failure of the life support device or system, or to affect its safety or effectiveness.

PRODUCT STATUS DEFINITIONS

Definition of Terms

Datasheet Identification	Product Status	Definition
Advance Information	Formative or In Design	This datasheet contains the design specifications for product development. Specifications may change in any manner without notice.
Preliminary	First Production	This datasheet contains preliminary data; supplementary data will be published at a later date. Fairchild Semiconductor reserves the right to make changes at any time without notice to improve design.
No Identification Needed	Full Production	This datasheet contains final specifications. Fairchild Semiconductor reserves the right to make changes at any time without notice to improve design.
Obsolete	Not In Production	This datasheet contains specifications on a product that has been discontinued by Fairchild Semiconductor. The datasheet is printed for reference information only.

Rev. 131