



STEVAl-IHM021V1

100 W 3-phase inverter for speed FOC of 3-phase PMSM motor drive based on the L6390 and STD5NK52ZD-1

Data Brief

Features

- Input voltage wide range (110 Vac and 230 Vac)
- Maximum power-up to 100 W at 230 Vac input voltage
- Power MOSFET STD5NK52ZD-1(4.4 A 520 V)
- Compatible with other power MOSFET's in IPAK packages
- +15 V auxiliary power supply connector
- Connector for interface with STM3210B-EVAL board
- Target applications:
 - Refrigerators compressors
 - Dishwasher pumps.



Description

This demonstration board implements a 100 W 3-phase inverter with field oriented control (FOC) of permanent magnet synchronous motors (PMSM).

This board, consists in a 3-phase inverter bridge based on the STD5NK52ZD-1 power MOSFET in IPAK package and on the L6390, the latest high voltage half-bridge gate driver, mainly featuring an integrated comparator for faultware protections implementation (e.g. against over-current, over-temperature, etc.) and an embedded operational amplifier suitable for advanced current sensing.

The board has been designed to be compatible with 110 Vac and 230 Vac mains and it includes a power supply stage with VIPer12AS-E (in buck configuration) to generate the +15 V and +3.3 V supply voltage required by the application.

The board can be interfaced via a dedicated connector with STM3210B-EVAL, the STM32 microcontroller demonstration board.

The previous code was: EVAL6390D.

November 2008

Rev 1

1/5

For further information contact your local STMicroelectronics sales office.

www.st.com

1 Circuit schematic

Figure 1. Inverter schematic

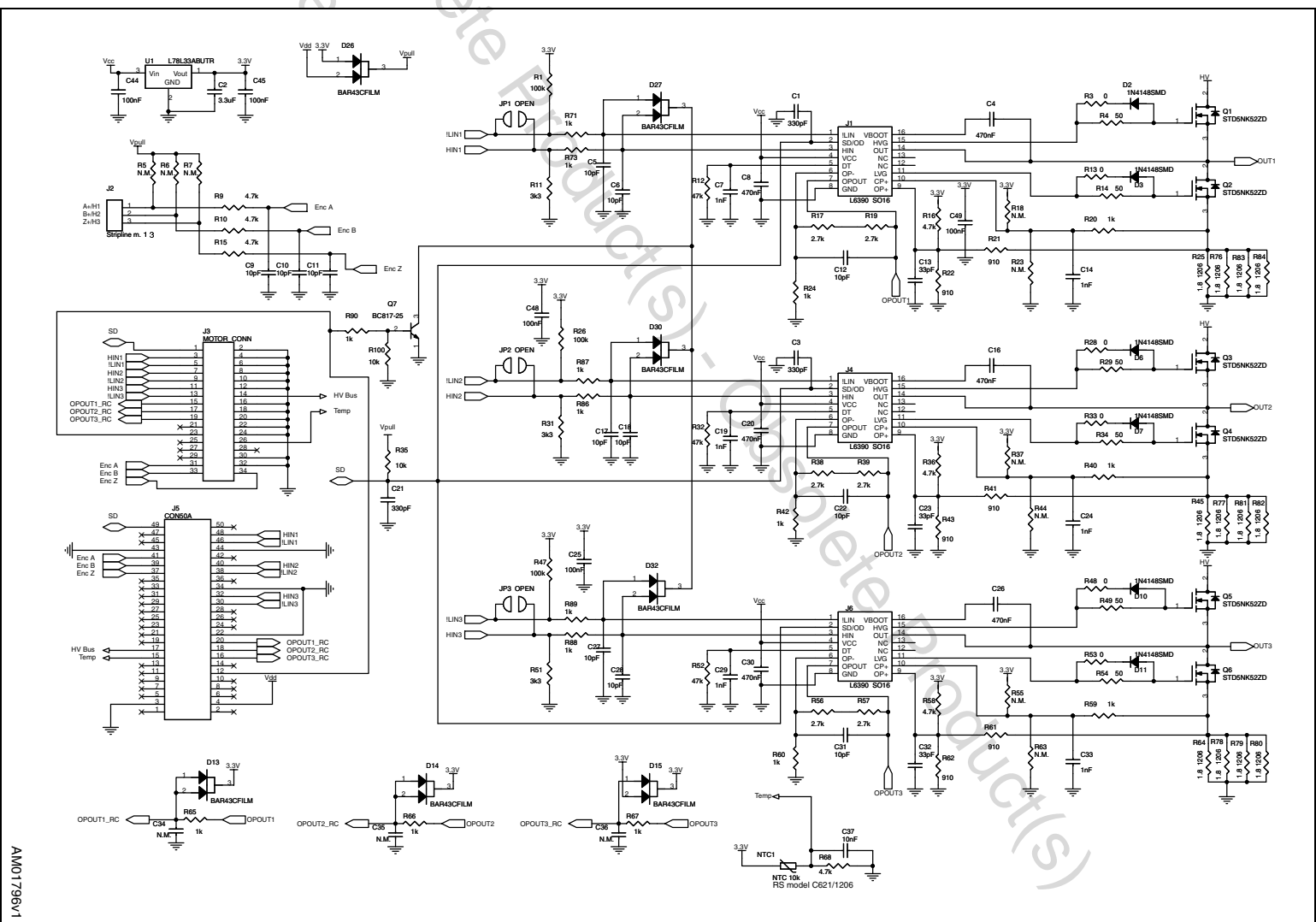

AM01796V1



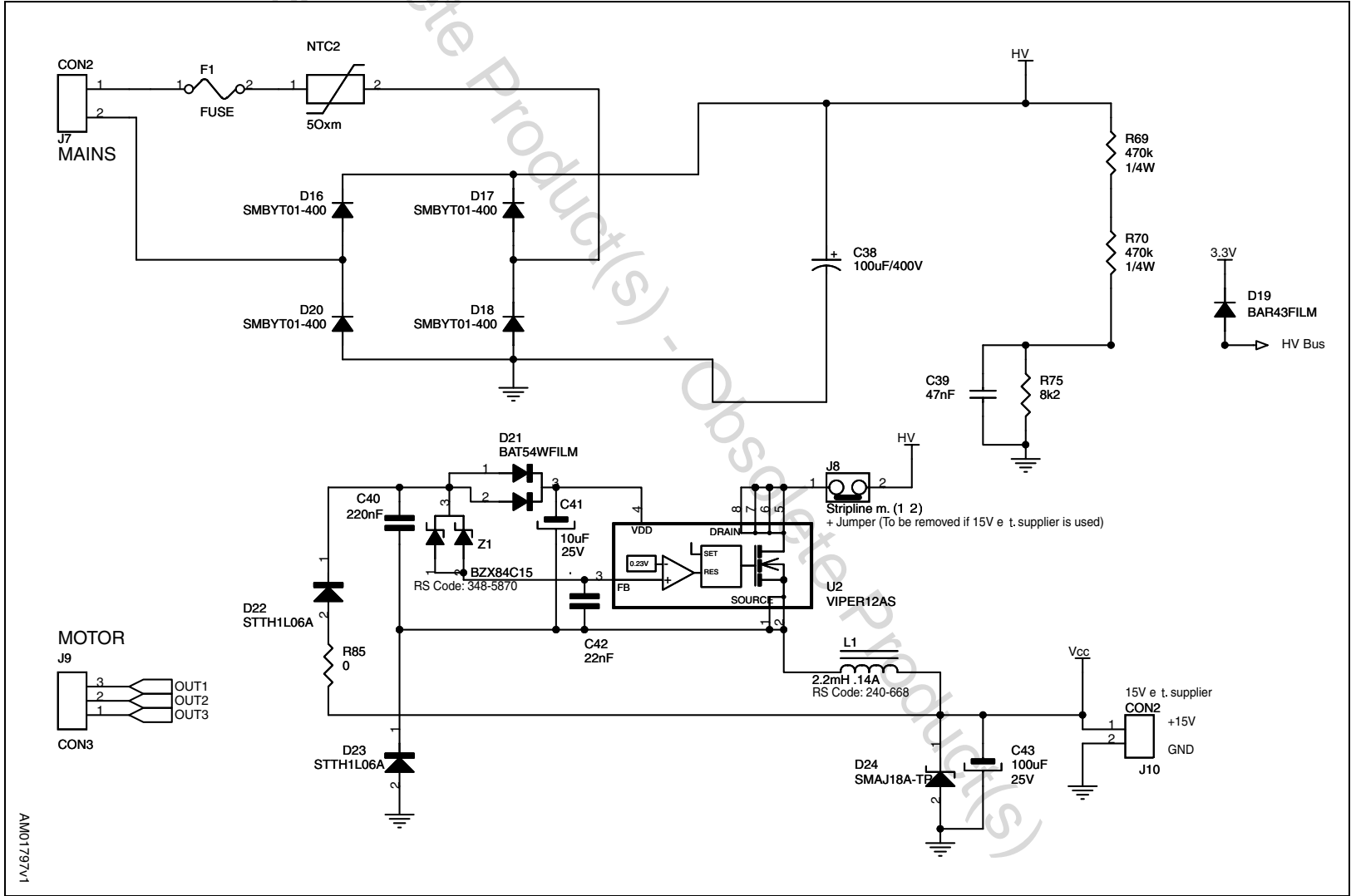

2 Revision history

Table 1. Document revision history

Date	Revision	Changes
04-Nov-2008	1	Initial release.

Obsolete Product(s) - Obsolete Product(s)
Obsolete Product(s) - Obsolete Product(s)
Obsolete Product(s) - Obsolete Product(s)

Please Read Carefully:

Information in this document is provided solely in connection with ST products. STMicroelectronics NV and its subsidiaries ("ST") reserve the right to make changes, corrections, modifications or improvements, to this document, and the products and services described herein at any time, without notice.

All ST products are sold pursuant to ST's terms and conditions of sale.

Purchasers are solely responsible for the choice, selection and use of the ST products and services described herein, and ST assumes no liability whatsoever relating to the choice, selection or use of the ST products and services described herein.

No license, express or implied, by estoppel or otherwise, to any intellectual property rights is granted under this document. If any part of this document refers to any third party products or services it shall not be deemed a license grant by ST for the use of such third party products or services, or any intellectual property contained therein or considered as a warranty covering the use in any manner whatsoever of such third party products or services or any intellectual property contained therein.

UNLESS OTHERWISE SET FORTH IN ST'S TERMS AND CONDITIONS OF SALE ST DISCLAIMS ANY EXPRESS OR IMPLIED WARRANTY WITH RESPECT TO THE USE AND/OR SALE OF ST PRODUCTS INCLUDING WITHOUT LIMITATION IMPLIED WARRANTIES OF MERCHANTABILITY, FITNESS FOR A PARTICULAR PURPOSE (AND THEIR EQUIVALENTS UNDER THE LAWS OF ANY JURISDICTION), OR INFRINGEMENT OF ANY PATENT, COPYRIGHT OR OTHER INTELLECTUAL PROPERTY RIGHT. UNLESS EXPRESSLY APPROVED IN WRITING BY AN AUTHORIZED ST REPRESENTATIVE, ST PRODUCTS ARE NOT RECOMMENDED, AUTHORIZED OR WARRANTED FOR USE IN MILITARY, AIR CRAFT, SPACE, LIFE SAVING, OR LIFE SUSTAINING APPLICATIONS, NOR IN PRODUCTS OR SYSTEMS WHERE FAILURE OR MALFUNCTION MAY RESULT IN PERSONAL INJURY, DEATH, OR SEVERE PROPERTY OR ENVIRONMENTAL DAMAGE. ST PRODUCTS WHICH ARE NOT SPECIFIED AS "AUTOMOTIVE GRADE" MAY ONLY BE USED IN AUTOMOTIVE APPLICATIONS AT USER'S OWN RISK.

Resale of ST products with provisions different from the statements and/or technical features set forth in this document shall immediately void any warranty granted by ST for the ST product or service described herein and shall not create or extend in any manner whatsoever, any liability of ST.

ST and the ST logo are trademarks or registered trademarks of ST in various countries.

Information in this document supersedes and replaces all information previously supplied.

The ST logo is a registered trademark of STMicroelectronics. All other names are the property of their respective owners.

© 2008 STMicroelectronics - All rights reserved

STMicroelectronics group of companies

Australia - Belgium - Brazil - Canada - China - Czech Republic - Finland - France - Germany - Hong Kong - India - Israel - Italy - Japan - Malaysia - Malta - Morocco - Singapore - Spain - Sweden - Switzerland - United Kingdom - United States of America

www.st.com

