



### SPECIFICATIONS

Model	Stroke mm	Max Energy Absorption J(kgf·m)	Max Equiv. Mass kg(kgf)	Range of Impact Rate m/s
FA-3625A3-C	25	200(20.4)	700(700)	0.7~3.0

### COMMON SPECIFICATIONS

Max Drag N(kgf)	Max Cycle Rate cycle/min	Max Energy Absorption per min. J/min(kgf·m/min)	Extension Force N(kgf)	Operating Temp. C°	Mass g
25000(2551)	30	1500(153)	100(10.2) or lower	-5~70	780

### PRECAUTIONS FOR USE

- Do not use this product without carefully reading the attached owner's manual.
- Ensure that an external stopper (Stopper nut OP-020M36) is also used.
- Do not turn the oil inlet screw located at the bottom of the main unit.
- Ensure that sufficient mounting strength is secured for this product. (As a guideline, it should be 2 to 3 times the maximum drag listed in the catalogue.)
- Do not use this product in a vacuum or a location where it may come in contact with oil.
- Ensure that an eccentric load is not applied to the soft absorber. (Allowable eccentric angle: within  $\pm 2.5^\circ$ )

### ADJUSTMENT METHOD

- To adjust, turn the adjustment knob located at the bottom of the main unit.
- Because the adjustment can be done in an analog manner, a value between two integers on the indicator can be set.
- Once the adjustment is complete, secure with a lock screw using a hex wrench.

### ABSORPTION CHARACTERISTICS

Orifice type	Multiple-orifice type	Absorption characteristics 
Model number	FA-3625A3-C	
Application	For high speed	

## OPTIONAL PARTS

### Eccentric angle adaptor OP-010M3625

- Screw an inclination angle adapter in the main unit until the backlash between the inclination angle cap and the piston rod is eliminated, and securely tighten the nut for the main unit at that position.
- For an inclination angle  $2.5^\circ \leq$ .
- The inclination angle guide can be used as a stopper as well.
- The soft absorber cannot be used with an optional urethane cap on.
- The maximum inclination angle for use with inclination angle adapter is  $\pm 10^\circ$
- The caps and the guides for inclined use are not unbundled.

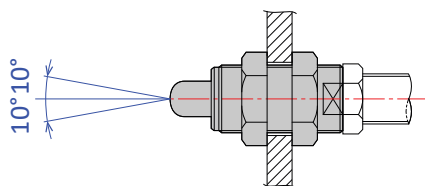
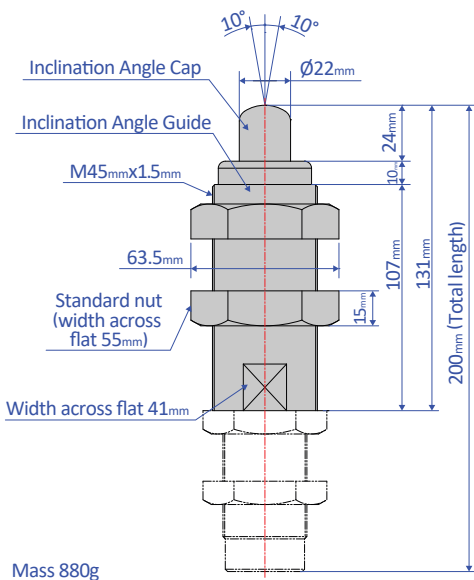

Note: Material of cap for eccentric angle: Metal

### Square flange OP-040UB

- Once the attachment site is determined, use the main unit's nut to securely fasten in place.

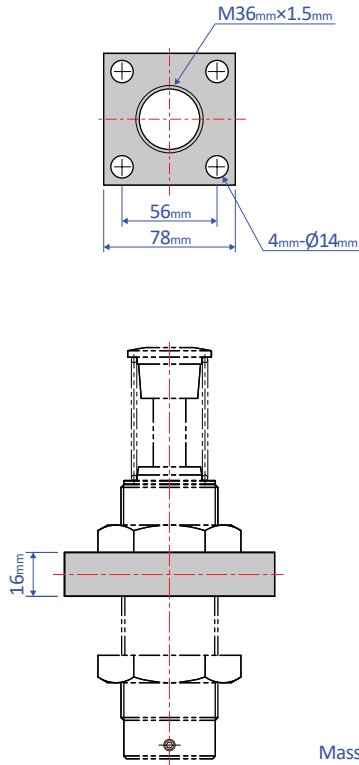

### Urethane cap OP-090M36B

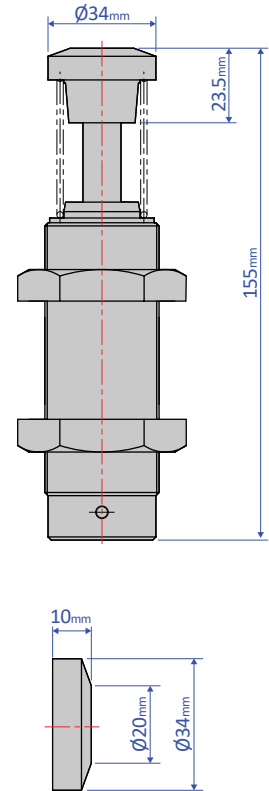

Mass 7g

Dimensions with urethane cap attached

### Stopper nut OP-020M36

- Adjust so that it stops 1 mm before the stroke end, and fasten with the main unit's nut until secured.

OP-020M36

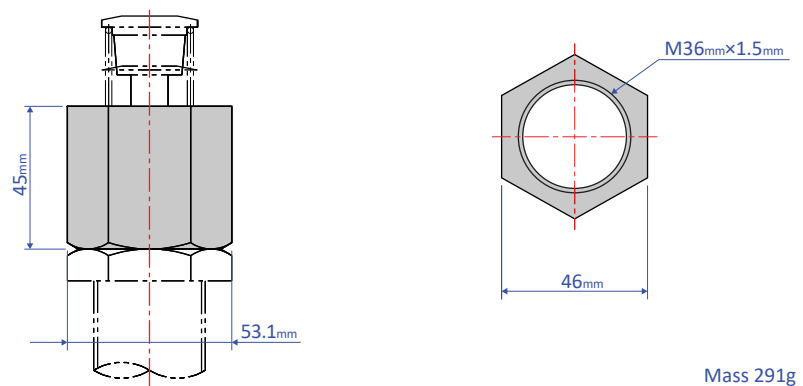

Note: When attaching, make sure that the side without a bearing chamfer is the impact surface.

Standard nuts are sold separately as well - M36 Nut