



# LC87F5M64A

CMOS IC

FROM 64K byte, RAM 2048 byte on-chip

## 8-bit 1-chip Microcontroller

ON Semiconductor®

<http://onsemi.com>

### Overview

The LC87F5M64A is an 8-bit microcomputer that, integrates on a single chip a number of hardware features such as 64K-byte flash ROM, 2048-byte RAM, On-chip debugging function, a 16-bit timer/counter, four 8-bit timers, a base timer serving as a time-of-day clock, a high-speed clock counter, a synchronous SIO interface (with automatic block transmission/reception capabilities), an asynchronous/synchronous SIO port, two UART ports, an 11-channel AD converter, two 12-bit PWM channels, a system clock frequency divider, and an interrupt feature.

### Features

#### ■Flash ROM

- 65536 × 8 bits
- Capable of on-board-programing with wide range, 2.7 to 5.5V, of voltage source
- Block-erasable in 128 byte units

#### ■RAM

- 2048 × 9 bits

#### ■Package Form

- QIP64E (14 × 14) : "Lead-free and halogen-free type"

### Package Dimensions

unit : mm (typ)

3159A

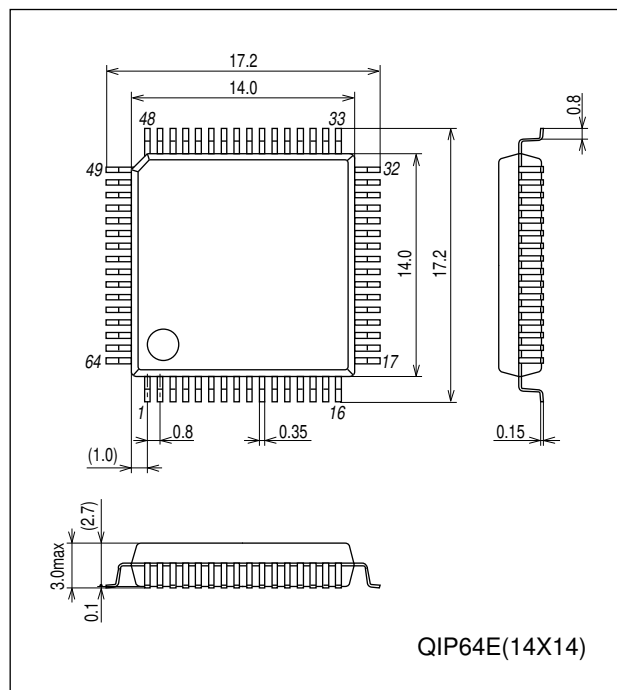

\* This product is licensed from Silicon Storage Technology, Inc. (USA).

# LC87F5M64A

## ■ Minimum Bus Cycle Time

- 83.3ns (12MHz)  $V_{DD}=2.8$  to 5.5V
- 125ns (8MHz)  $V_{DD}=2.5$  to 5.5V
- 500ns (2MHz)  $V_{DD}=2.2$  to 5.5V

Note: The bus cycle time here refers to the ROM read speed.

## ■ Minimum Instruction Cycle Time (tCYC)

- 250ns (12MHz)  $V_{DD}=2.8$  to 5.5V
- 375ns (8MHz)  $V_{DD}=2.5$  to 5.5V
- 1.5 $\mu$ s (2MHz)  $V_{DD}=2.2$  to 5.5V

## ■ Ports

- Normal withstand voltage I/O ports
  - Ports whose I/O direction can be designated in 1-bit units 46 (P1n, P2n, P3n, P70 to P73, P80 to P86, PCn, PWM2, PWM3, XT2)
  - Ports whose I/O direction can be designated in 4-bit units 8 (P0n)
- Normal withstand voltage input port 1 (XT1)
- Dedicated oscillator ports 2 (CF1, CF2)
- Reset pins 1 (RES)
- Power pins 6 ( $V_{SS1}$  to 3,  $V_{DD1}$  to 3)

## ■ Timers

- Timer 0: 16-bit timer/counter with a capture register
  - Mode 0: 8-bit timer with an 8-bit programmable prescaler (with an 8-bit capture register)  $\times 2$  channels
  - Mode 1: 8-bit timer with an 8-bit programmable prescaler (with an 8-bit capture register) + 8-bit counter (with an 8-bit capture register)
  - Mode 2: 16-bit timer with an 8-bit programmable prescaler (with a 16-bit capture register)
  - Mode 3: 16-bit counter (with a 16-bit capture register)
- Timer 1: 16-bit timer/counter that supports PWM/toggle outputs
  - Mode 0: 8-bit timer with an 8-bit prescaler (with toggle outputs) + 8-bit timer/counter with an 8-bit prescaler (with toggle outputs)
  - Mode 1: 8-bit PWM with an 8-bit prescaler  $\times 2$  channels
  - Mode 2: 16-bit timer/counter with an 8-bit prescaler (with toggle outputs) (toggle outputs also possible from the lower-order 8-bits)
  - Mode 3: 16-bit timer with an 8-bit prescaler (with toggle outputs) (The lower-order 8 bits can be used as PWM)
- Timer 4: 8-bit timer with a 6-bit prescaler
- Timer 5: 8-bit timer with a 6-bit prescaler
- Timer 6: 8-bit timer with a 6-bit prescaler (with toggle outputs)
- Timer 7: 8-bit timer with a 6-bit prescaler (with toggle outputs)
- Base timer
  - 1) The clock is selectable from the subclock (32.768kHz crystal oscillation), system clock, and timer 0 prescaler output.
  - 2) Interrupts programmable in 5 different time schemes.

## ■ High-speed Clock Counter

- 1) Can count clocks with a maximum clock rate of 24MHz (at a main clock of 12MHz)
- 2) Can generate output real-time.

## ■ SIO

- SIO0: 8-bit synchronous serial interface
  - 1) LSB first/MSB first mode selectable
  - 2) Built-in 8-bit baudrate generator (maximum transfer clock cycle =  $4/3$  tCYC)
  - 3) Automatic continuous data transmission (1 to 256 bits, specifiable in 1 bit units, suspension and resumption of data transmission possible in 1 byte units)
- SIO1: 8-bit asynchronous/synchronous serial interface
  - Mode 0: Synchronous 8-bit serial I/O (2- or 3-wire configuration, 2 to 512 tCYC transfer clocks)
  - Mode 1: Asynchronous serial I/O (half-duplex, 8 data bits, 1 stop bit, 8 to 2048 tCYC baudrates)
  - Mode 2: Bus mode 1 (start bit, 8 data bits, 2 to 512 tCYC transfer clocks)
  - Mode 3: Bus mode 2 (start detect, 8 data bits, stop detect)

# LC87F5M64A

## ■UART: 2 channels

- Full duplex
- 7/8/9 bit data bits selectable
- 1 stop bit (2 bit in continuous data transmission)
- Built-in baudrate generator (with baudrates of 16/3 to 8192/3 tCYC)

## ■AD Converter: 8 bits × 11 channels

## ■PWM: Multifrequency 12-bit PWM × 2 channels

## ■Remote Control Receiver Circuit (sharing pins with P73, INT3, and T0IN)

- 1) Noise filtering function (noise filter time constant selectable from 1 tCYC, 32 tCYC, and 128 tCYC)
- 2) The noise filtering function is available for the INT3, T0IN, or T0HCP signal at P73. When P73 is read with an instruction, the signal level at that pin is read regardless of the availability of the noise filtering function.

## ■Watchdog Timer

- External RC watchdog timer
- Interrupt and reset signals selectable

## ■Clock Output Function

- 1) Able to output selected oscillation clock 1/1, 1/2, 1/4, 1/8, 1/16, 1/32, 1/64 as system clock.
- 2) Able to output oscillation clock of sub clock.

## ■Interrupts

- 27 sources, 10 vector addresses
  - 1) Provides three levels (low (L), high (H), and highest (X)) of multiplex interrupt control. Any interrupt requests of the level equal to or lower than the current interrupt are not accepted.
  - 2) When interrupt requests to two or more vector addresses occur at the same time, the interrupt of the highest level takes precedence over the other interrupts. For interrupts of the same level, the interrupt into the smallest vector address takes precedence.

No.	Vector Address	Level	Interrupt Source
1	00003H	X or L	INT0
2	0000BH	X or L	INT1
3	00013H	H or L	INT2/T0L/INT4
4	0001BH	H or L	INT3/INT5/base timer0/base timer1
5	00023H	H or L	T0H/INT6
6	0002BH	H or L	T1L/T1H/INT7
7	00033H	H or L	SIO0/UART1 receive/UART2 receive
8	0003BH	H or L	SIO1/UART1 transmit/UART2 transmit
9	00043H	H or L	ADC/T6/T7
10	0004BH	H or L	Port 0/T4/T5/PWM2, PWM3

- Priority levels  $X > H > L$
- Of interrupts of the same level, the one with the smallest vector address takes precedence.

## ■Subroutine Stack Levels: 1024 levels (the stack is allocated in RAM)

## ■High-speed Multiplication/Division Instructions

- 16-bits × 8-bits (5 tCYC execution time)
- 24-bits × 16-bits (12 tCYC execution time)
- 16-bits ÷ 8-bits (8 tCYC execution time)
- 24-bits ÷ 16-bits (12 tCYC execution time)

## ■Oscillation Circuits

- RC oscillation circuit (internal) : For system clock
- CF oscillation circuit : For system clock, with internal Rf
- Crystal oscillation circuit : For low-speed system clock
- Multifrequency RC oscillation circuit (internal) : For system clock

# LC87F5M64A

## ■System Clock Divider Function

- Can run on low current.
- The minimum instruction cycle selectable from 250ns, 500ns, 1.0μs, 2.0μs, 4.0μs, 8.0μs, 16.0μs, 32.0μs, and 64.0μs (at a main clock rate of 12MHz).

## ■Standby Function

- HALT mode: Halts instruction execution while allowing the peripheral circuits to continue operation.
  - 1) Oscillation is not halted automatically.
  - 2) Canceled by a system reset or occurrence of an interrupt.
- HOLD mode: Suspends instruction execution and the operation of the peripheral circuits.
  - 1) The CF, RC, and crystal oscillators automatically stop operation.
  - 2) There are three ways of resetting the HOLD mode.
    - (1) Setting the reset pin to the lower level.
    - (2) Setting at least one of the INT0, INT1, INT2, INT4, and INT5 pins to the specified level
    - (3) Having an interrupt source established at port 0
- X'tal HOLD mode: Suspends instruction execution and the operation of the peripheral circuits except the base timer.
  - 1) The CF and RC oscillators automatically stop operation.
  - 2) The state of crystal oscillation established when the X'tal HOLD mode is entered is retained.
  - 3) There are four ways of resetting the X'tal HOLD mode.
    - (1) Setting the reset pin to the low level
    - (2) Setting at least one of the INT0, INT1, INT2, INT4, and INT5 pins to the specified level
    - (3) Having an interrupt source established at port 0
    - (4) Having an interrupt source established in the base timer circuit

## ■On-chip Debugger Function

- Permits software debugging with the test device installed on the target board.

## ■Development Tools

- Evaluation (EVA) chip : LC87EV690
- Emulator : EVA62S + ECB876600D + SUB875M00 + POD64QFP  
ICE-B877300 + SUB875M00 + POD64QFP
- On-chip-debugger : TCB87-TypeB + LC87F5M64A

## ■Programming Boards

Package	Programming boards
QIP64E(14 × 14)	W87F50256Q

## ■Flash ROM Programmer

Maker	Model	Support version(Note)	Device
Flash Support Group, Inc.(Single)	AF9708/09/09B (including product of Ando Electric Co.,Ltd)	Revision : After Rev.02.73	LC87F6D64A
Flash Support Group, Inc.(Gang)	AF9723(Main body) (including product of Ando Electric Co.,Ltd)	Revision : After Rev.02.29	LC87F5M64A
	AF9833(Unit) (including product of Ando Electric Co.,Ltd)	Revision : After Rev.01.88	
Our company	SKK/SKK Type-B/SKK DBG Type-B (SANYO FWS)	Application Version: After 1.04 Chip Data Version: After2.10	LC87F5M64A

# LC87F5M64A

## Pin Assignment

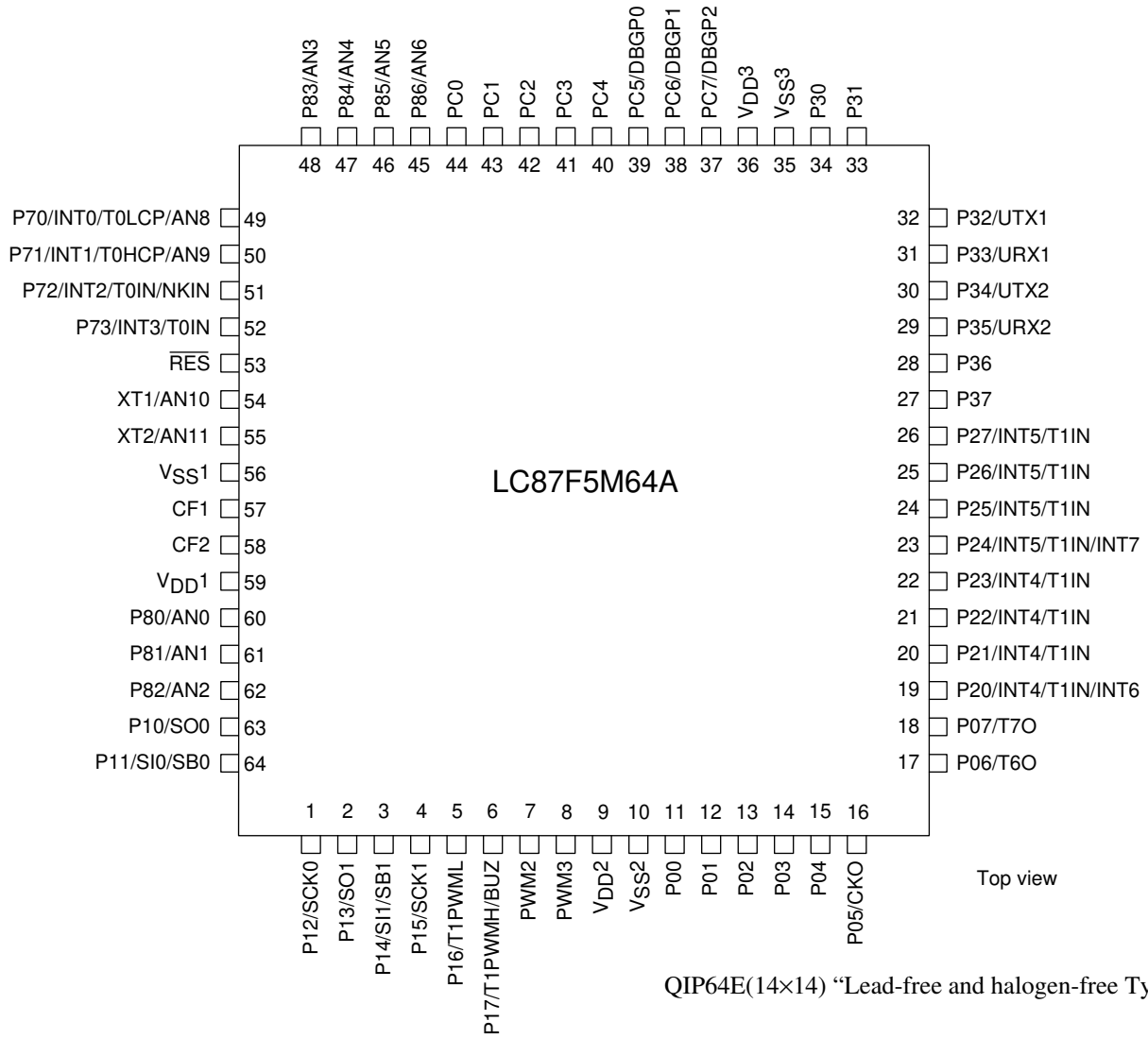

# LC87F5M64A

## System Block Diagram

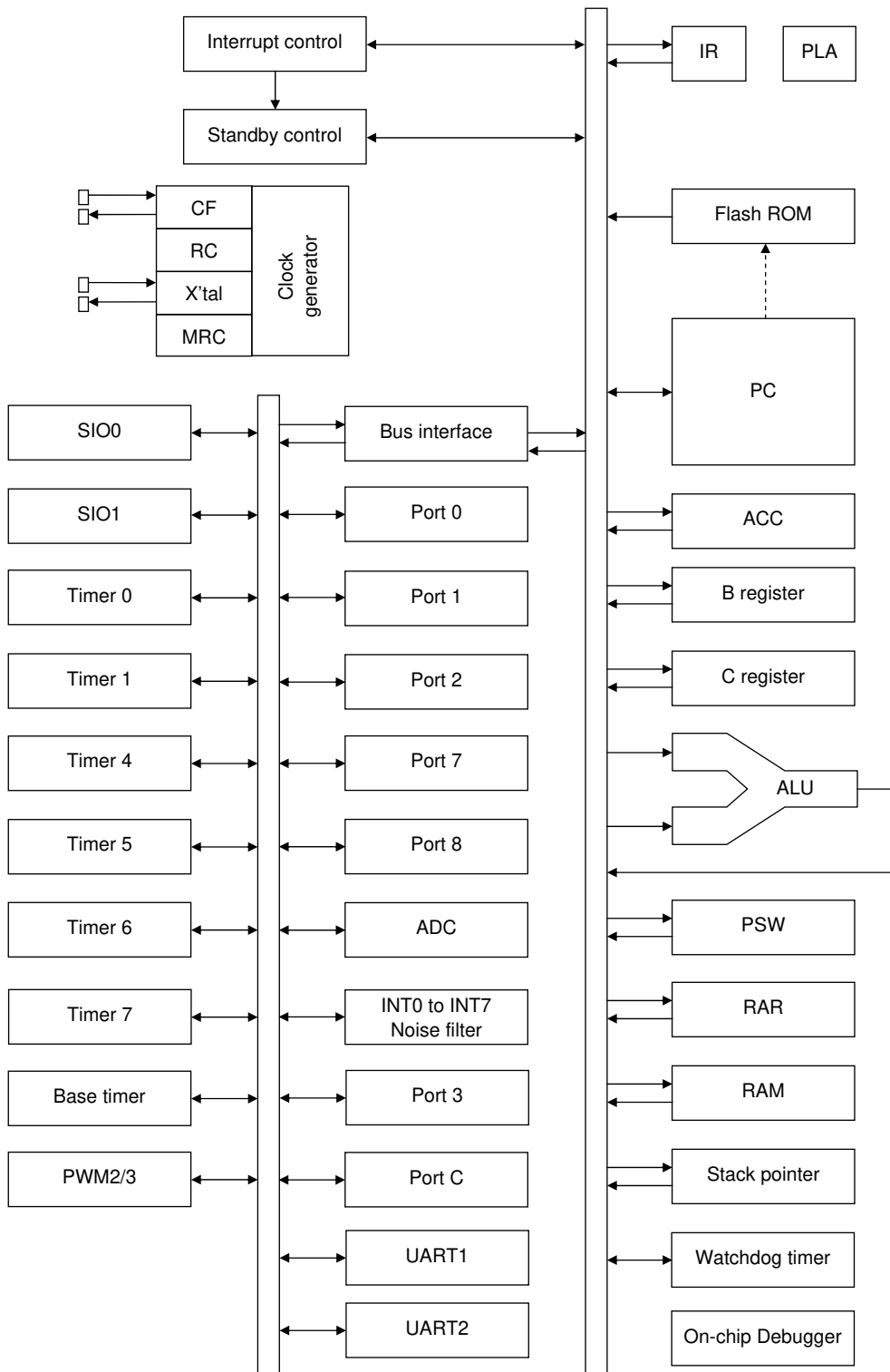

# LC87F5M64A

## Pin Description

Pin Name	I/O	Description	Option																														
V <sub>SS1</sub> , V <sub>SS2</sub> V <sub>SS3</sub>	-	- Power supply pin	No																														
V <sub>DD1</sub> , V <sub>DD2</sub> V <sub>DD3</sub>	-	+ Power supply pin	No																														
Port 0 P00 to P07	I/O	<ul style="list-style-type: none"> <li>• 8-bit I/O port</li> <li>• I/O specifiable in 4-bit units</li> <li>• Pull-up resistor can be turned on and off in 4-bit units</li> <li>• HOLD release input</li> <li>• Port 0 interrupt input</li> <li>• Shared Pins</li> </ul> P05: Clock output (system clock/can selected from sub clock) P06: Timer 6 toggle output P07: Timer 7 toggle output	Yes																														
Port 1 P10 to P17	I/O	<ul style="list-style-type: none"> <li>• 8-bit I/O port</li> <li>• I/O specifiable in 1-bit units</li> <li>• Pull-up resistor can be turned on and off in 1-bit units</li> <li>• Pin functions</li> </ul> P10: SIO0 data output P11: SIO0 data input/bus I/O P12: SIO0 clock I/O P13: SIO1 data output P14: SIO1 data input/bus I/O P15: SIO1 clock I/O P16: Timer 1 PWML output P17: Timer 1 PWMH output/beeper output	Yes																														
Port 2 P20 to P27	I/O	<ul style="list-style-type: none"> <li>• 8-bit I/O port</li> <li>• I/O specifiable in 1-bit units</li> <li>• Pull-up resistor can be turned on and off in 1-bit units</li> <li>• Other functions</li> </ul> P20: INT4 input/HOLD reset input/timer 1 event input/timer 0L capture input/ timer 0H capture input/INT6 input/timer 0L capture 1 input P21 to P23: INT4 input/HOLD reset input/timer 1 event input/timer 0L capture input/ timer 0H capture input P24: INT5 input/HOLD reset input/timer 1 event input/timer 0L capture input/ timer 0H capture input/INT7 input/timer 0H capture 1 input P25 to P27: INT5 input/HOLD reset input/timer 1 event input/timer 0L capture input/ timer 0H capture input <ul style="list-style-type: none"> <li>• Interrupt acknowledge type</li> </ul> <table border="1" style="width: 100%; border-collapse: collapse; text-align: center;"> <thead> <tr> <th></th> <th>Rising</th> <th>Falling</th> <th>Rising/ Falling</th> <th>H level</th> <th>L level</th> </tr> </thead> <tbody> <tr> <td>INT4</td> <td>enable</td> <td>enable</td> <td>enable</td> <td>disable</td> <td>disable</td> </tr> <tr> <td>INT5</td> <td>enable</td> <td>enable</td> <td>enable</td> <td>disable</td> <td>disable</td> </tr> <tr> <td>INT6</td> <td>enable</td> <td>enable</td> <td>enable</td> <td>disable</td> <td>disable</td> </tr> <tr> <td>INT7</td> <td>enable</td> <td>enable</td> <td>enable</td> <td>disable</td> <td>disable</td> </tr> </tbody> </table>		Rising	Falling	Rising/ Falling	H level	L level	INT4	enable	enable	enable	disable	disable	INT5	enable	enable	enable	disable	disable	INT6	enable	enable	enable	disable	disable	INT7	enable	enable	enable	disable	disable	Yes
	Rising	Falling	Rising/ Falling	H level	L level																												
INT4	enable	enable	enable	disable	disable																												
INT5	enable	enable	enable	disable	disable																												
INT6	enable	enable	enable	disable	disable																												
INT7	enable	enable	enable	disable	disable																												

Continued on next page.

# LC87F5M64A

Continued from preceding page.

Pin Name	I/O	Description	Option																														
Port 7 P70 to P73	I/O	<ul style="list-style-type: none"> <li>• 4-bit I/O port</li> <li>• I/O specifiable in 1-bit units</li> <li>• Pull-up resistor can be turned on and off in 1-bit units</li> <li>• Shared Pins</li> </ul> P70: INT0 input/HOLD reset input/timer 0L capture input/watchdog timer output P71: INT1 input/HOLD reset input/timer 0H capture input P72: INT2 input/HOLD reset input/timer 0 event input/timer 0L capture input/ high speed clock counter input P73: INT3 input (with noise filter)/timer 0 event input/timer 0H capture input AD converter input port: AN8 (P70), AN9 (P71) <ul style="list-style-type: none"> <li>• Interrupt acknowledge type</li> </ul> <table border="1" style="margin-left: 20px;"> <thead> <tr> <th></th> <th>Rising</th> <th>Falling</th> <th>Rising/ Falling</th> <th>H level</th> <th>L level</th> </tr> </thead> <tbody> <tr> <td>INT0</td> <td>enable</td> <td>enable</td> <td>disable</td> <td>enable</td> <td>enable</td> </tr> <tr> <td>INT1</td> <td>enable</td> <td>enable</td> <td>disable</td> <td>enable</td> <td>enable</td> </tr> <tr> <td>INT2</td> <td>enable</td> <td>enable</td> <td>enable</td> <td>disable</td> <td>disable</td> </tr> <tr> <td>INT3</td> <td>enable</td> <td>enable</td> <td>enable</td> <td>disable</td> <td>disable</td> </tr> </tbody> </table>		Rising	Falling	Rising/ Falling	H level	L level	INT0	enable	enable	disable	enable	enable	INT1	enable	enable	disable	enable	enable	INT2	enable	enable	enable	disable	disable	INT3	enable	enable	enable	disable	disable	No
	Rising	Falling	Rising/ Falling	H level	L level																												
INT0	enable	enable	disable	enable	enable																												
INT1	enable	enable	disable	enable	enable																												
INT2	enable	enable	enable	disable	disable																												
INT3	enable	enable	enable	disable	disable																												
Port 8 P80 to P86	I/O	<ul style="list-style-type: none"> <li>• 7-bit I/O port</li> <li>• I/O specifiable in 1-bit units</li> <li>• Shared Pins</li> </ul> AD converter input port : AN0 (P80) to AN6 (P86)	No																														
PWM2 PWM3	I/O	<ul style="list-style-type: none"> <li>• PWM2 and PWM3 output ports</li> <li>• General-purpose I/O available</li> </ul>	No																														
Port 3 P30 to P37	I/O	<ul style="list-style-type: none"> <li>• 8-bit I/O port</li> <li>• I/O specifiable in 1-bit units</li> <li>• Pull-up resistor can be turned on and off in 1-bit units</li> <li>• Pin functions</li> </ul> P32: UART1 transmit P33: UART1 receive P34: UART2 transmit P35: UART2 receive	Yes																														
Port C PC0 to PC7	I/O	<ul style="list-style-type: none"> <li>• 8-bit I/O port</li> <li>• I/O specifiable in 1-bit units</li> <li>• Pull-up resistor can be turned on and off in 1-bit units</li> <li>• Pin functions</li> </ul> DBG P0 to DBG P2(PC5 to PC7): On-chip Debugger	Yes																														
$\overline{\text{RES}}$	Input	Reset pin	No																														
XT1	Input	<ul style="list-style-type: none"> <li>• 32.768kHz crystal oscillator input pin</li> <li>• Shared pins</li> </ul> General-purpose input port AD converter input port : AN10 Must be connected to V <sub>DD1</sub> if not to be used.	No																														
XT2	I/O	<ul style="list-style-type: none"> <li>• 32.768kHz crystal oscillator input pin</li> <li>• Shared pins</li> </ul> General-purpose I/O port AD converter input port : AN11 Must be set for oscillation and kept open if not to be used.	No																														
CF1	Input	Ceramic resonator input pin	No																														
CF2	Output	Ceramic resonator output pin	No																														



# LC87F5M64A

## Port Output Types

The table below lists the types of port outputs and the presence/absence of a pull-up resistor. Data can be read into any input port even if it is in the output mode.

Port Name	Options Selected in Units of	Option Type	Output Type	Pull-up Resistor
P00 to P07	1 bit	1	CMOS	Programmable (Note 1)
		2	Nch-open drain	No
P10 to P17	1 bit	1	CMOS	Programmable
		2	Nch-open drain	Programmable
P20 to P27	1 bit	1	CMOS	Programmable
		2	Nch-open drain	Programmable
P70	-	No	Nch-open drain	Programmable
P71 to P73	-	No	CMOS	Programmable
P80 to P86	-	No	Nch-open drain	No
PWM2, PWM3	-	No	CMOS	No
P30 to P37	1 bit	1	CMOS	Programmable
		2	Nch-open drain	Programmable
PC0 to PC7	1 bit	1	CMOS	Programmable
		2	Nch-open drain	Programmable
XT1	-	No	Input for 32.768kHz crystal oscillator (Input only)	No
XT2	-	No	Output for 32.768kHz crystal oscillator (Nch-open drain when in general-purpose output mode)	No

Note 1: Programmable pull-up resistors for port 0 are controlled in 4-bit units (P00 to 03, P04 to 07).

\*1: Make the following connection to minimize the noise input to the V<sub>DD1</sub> pin and prolong the backup time. Be sure to electrically short the V<sub>SS1</sub>, V<sub>SS2</sub>, and V<sub>SS3</sub> pins.

(Example 1) When backup is active in the HOLD mode, the high level of the port outputs is supplied by the backup capacitors.

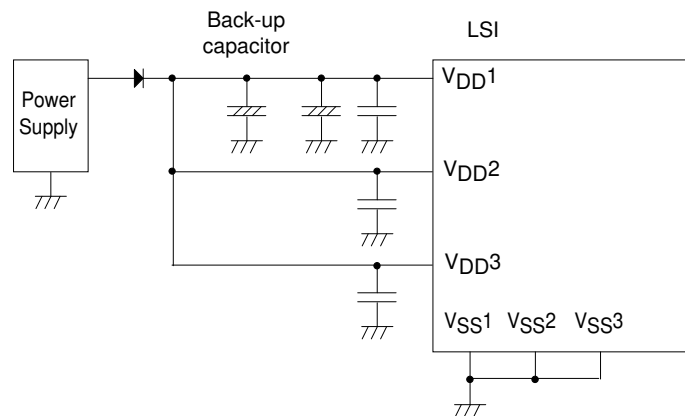

(Example 2) The high-level output at the ports is unstable when the HOLD mode backup is in effect.

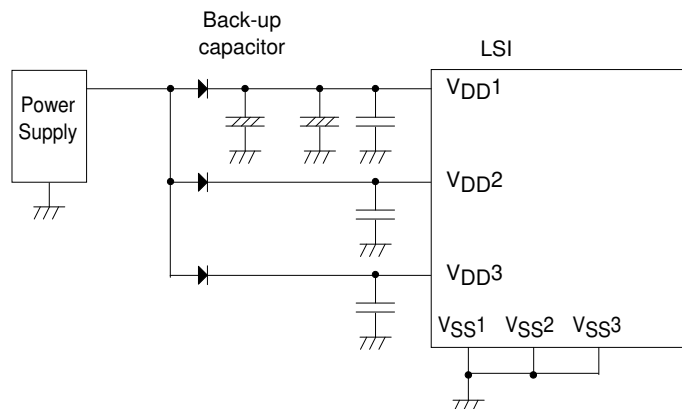

# LC87F5M64A

**Absolute Maximum Ratings** at Ta = 25°C, VSS1 = VSS2 = VSS3 = 0V

Parameter	Symbol	Pins/Remarks	Conditions	Specification				
				VDD[V]	min	typ	max	unit
Maximum supply voltage	VDD max	VDD1, VDD2, VDD3	VDD1=VDD2=VDD3		-0.3		+6.5	V
Input voltage	VI(1)	XT1, CF1			-0.3		VDD+0.3	
Input/Output voltage	VI(1)	Ports 0, 1, 2 Ports 7, 8 Ports 3, C PWM2, PWM3, XT2			-0.3		VDD+0.3	
High level output current	Peak output current	IOPH(1)	Ports 0, 1, 2 Ports 3, C	CMOS output select Per 1 application pin		-10		mA
		IOPH(2)	PWM2, PWM3	Per 1 application pin.		-20		
		IOPH(3)	P71 to P73	Per 1 application pin.		-5		
	Mean output current (Note1-1)	IOMH(1)	Ports 0, 1, 2 Ports 3, C	CMOS output select Per 1 application pin		-7.5		
		IOMH(2)	PWM2, PWM3	Per 1 application pin		-10		
		IOMH(3)	P71 to P73	Per 1 application pin		-3		
	Total output current	ΣIOAH(1)	P71 to P73	Total of all applicable pins		-10		
		ΣIOAH(2)	Ports, 1 PWM2, PWM3	Total of all applicable pins		-25		
		ΣIOAH(3)	Ports 0, 2	Total of all applicable pins		-25		
		ΣIOAH(4)	Ports 0, 1, 2 PWM2, PWM3	Total of all applicable pins		-45		
		ΣIOAH(5)	Port 3	Total of all applicable pins		-25		
		ΣIOAH(6)	Ports C	Total of all applicable pins		-25		
		ΣIOAH(7)	Ports 3, C	Total of all applicable pins		-45		
Low level output current	Peak output current	IOPL(1)	P02 to P07 Ports 1, 2 Ports 3, C PWM2, PWM3	Per 1 application pin			20	
		IOPL(2)	P00, P01	Per 1 application pin			30	
		IOPL(3)	Ports 7, 8, XT2	Per 1 application pin			10	
	Mean output current (Note1-1)	IOML(1)	P02 to P07 Ports 1, 2 Ports 3, C PWM2, PWM3	Per 1 application pin			15	
		IOML(2)	P00, P01	Per 1 application pin			20	
		IOML(3)	Ports 7, 8, XT2	Per 1 application pin			7.5	
	Total output current	ΣIOAL(1)	Port 7 P83 to P86, XT2	Total of all applicable pins			15	
		ΣIOAL(2)	P80 to P82	Total of all applicable pins			15	
		ΣIOAL(3)	Ports 7, 8, XT2	Total of all applicable pins			20	
		ΣIOAL(4)	Ports 1 PWM2, PWM3	Total of all applicable pins			45	
		ΣIOAL(5)	Ports 0, 2	Total of all applicable pins			45	
		ΣIOAL(6)	Ports 0, 1, 2 PWM2, PWM3	Total of all applicable pins			80	
		ΣIOAL(7)	Port 3	Total of all applicable pins			45	
ΣIOAL(8)		Ports C	Total of all applicable pins			45		
ΣIOAL(9)	Ports 3, C	Total of all applicable pins			80			
Maximum power dissipation	Pd max	QIP64E(14×14)	Ta=-40 to +85°C				300	mW
Operating ambient temperature	Topr				-40		+85	°C
Storage ambient temperature	Tstg				-55		+125	

Note 1-1: The mean output current is a mean value measured over 100ms.

Stresses exceeding Maximum Ratings may damage the device. Maximum Ratings are stress ratings only. Functional operation above the Recommended Operating Conditions is not implied. Extended exposure to stresses above the Recommended Operating Conditions may affect device reliability.

# LC87F5M64A

**Allowable Operating Conditions** at Ta = -40°C to +85°C, V<sub>SS1</sub> = V<sub>SS2</sub> = V<sub>SS3</sub> = 0V

Parameter	Symbol	Pins/Remarks	Conditions	Specification				unit	
				V <sub>DD</sub> [V]	min	typ	max		
Operating supply voltage (Note2-1)	V <sub>DD</sub> (1)	V <sub>DD1</sub> =V <sub>DD2</sub> =V <sub>DD3</sub>	0.245μs ≤ tCYC ≤ 200μs		2.8		5.5	V	
			0.367μs ≤ tCYC ≤ 200μs		2.5		5.5		
			1.47μs ≤ tCYC ≤ 200μs		2.2		5.5		
Memory sustaining supply voltage	V <sub>HD</sub>	V <sub>DD1</sub> =V <sub>DD2</sub> =V <sub>DD3</sub>	RAM and register contents sustained in HOLD mode		2.0		5.5		
High level input voltage	V <sub>IH</sub> (1)	Ports 1, 2 P71 to P73 P70 port input/ interrupt side		2.2 to 5.5	0.3V <sub>DD</sub> +0.7		V <sub>DD</sub>	V	
	V <sub>IH</sub> (2)	Ports 0, 8, 3, C PWM2, PWM3		2.2 to 5.5	0.3V <sub>DD</sub> +0.7		V <sub>DD</sub>		
	V <sub>IH</sub> (3)	P70 watchdog timer side		2.2 to 5.5	0.9V <sub>DD</sub>		V <sub>DD</sub>		
	V <sub>IH</sub> (4)	XT1, XT2, CF1, $\overline{\text{RES}}$		2.2 to 5.5	0.75V <sub>DD</sub>		V <sub>DD</sub>		
Low level input voltage	V <sub>IL</sub> (1)	Ports 1, 2 P71 to P73 P70 port input/ Interrupt side		4.0 to 5.5	V <sub>SS</sub>		0.1V <sub>DD</sub> +0.4	μs	
				2.2 to 4.0	V <sub>SS</sub>		0.2V <sub>DD</sub>		
	V <sub>IL</sub> (2)	Ports 0, 8, 3, C PWM2, PWM3		4.0 to 5.5	V <sub>SS</sub>		0.15V <sub>DD</sub> +0.4		
				2.2 to 4.0	V <sub>SS</sub>		0.2V <sub>DD</sub>		
V <sub>IL</sub> (3)	Port 70 watchdog timer side		2.2 to 5.5	V <sub>SS</sub>		0.8V <sub>DD</sub> -1.0			
V <sub>IL</sub> (4)	XT1, XT2, CF1, $\overline{\text{RES}}$		2.2 to 5.5	V <sub>SS</sub>		0.25V <sub>DD</sub>			
Instruction cycle time (Note2-2)	tCYC			2.8 to 5.5	0.245		200	μs	
				2.5 to 5.5	0.367		200		
				2.2 to 5.5	1.47		200		
External system clock frequency	FEXCF(1)	CF1	<ul style="list-style-type: none"> <li>• CF2 pin open</li> <li>• System clock frequency division rate=1/1</li> <li>• External system clock duty=50±5%</li> </ul>	2.8 to 5.5	0.1		12	MHz	
				2.5 to 5.5	0.1		8		
				2.2 to 5.5	0.1		2		
				<ul style="list-style-type: none"> <li>• CF2 pin open</li> <li>• System clock frequency division rate=1/2</li> </ul>	2.8 to 5.5	0.2			24.4
					2.5 to 5.5	0.1			16
					2.2 to 5.5	0.1			4
Oscillation frequency range (Note2-3)	FmCF(1)	CF1, CF2	12MHz ceramic oscillation See Fig. 1.	2.8 to 5.5		12		MHz	
	FmCF(2)	CF1, CF2	8MHz ceramic oscillation See Fig. 1.	2.5 to 5.5		8			
	FmCF(3)	CF1, CF2	4MHz ceramic oscillation See Fig. 1.	2.2 to 5.5		4			
	FmRC		Internal RC oscillation	2.2 to 5.5	0.3	1.0	2.0		
	FmMRC		Frequency variable RC oscillation source oscillation	2.5 to 5.5		16			
	FsX'tal	XT1, XT2	32.768kHz crystal oscillation See Fig. 2.	2.2 to 5.5		32.768			kHz

Note 2-1: V<sub>DD</sub> must be held greater than or equal to 2.7V in the flash ROM onboard programming mode.

Note 2-2: Relationship between tCYC and oscillation frequency is 3/FmCF at a division ratio of 1/1 and 6/FmCF at a division ratio of 1/2.

Note 2-3: See Tables 1 and 2 for the oscillation constants.

# LC87F5M64A

**Electrical Characteristics** at Ta = -40°C to +85°C, VSS1 = VSS2 = VSS3 = 0V

Parameter	Symbol	Pins/Remarks	Conditions	Specification				
				VDD[V]	min	typ	max	unit
High level input current	I <sub>IH</sub> (1)	Ports 0, 1, 2 Ports 7, 8 Ports 3, C $\overline{\text{RES}}$ PWM2, PWM3	Output disabled Pull-up resistor off V <sub>IN</sub> =V <sub>DD</sub> (Including output Tr's off leakage current)	2.2 to 5.5			1	μA
	I <sub>IH</sub> (2)	XT1, XT2	For input port specification V <sub>IN</sub> =V <sub>DD</sub>	2.2 to 5.5			1	
	I <sub>IH</sub> (3)	CF1	V <sub>IN</sub> =V <sub>DD</sub>	2.2 to 5.5			15	
Low level input current	I <sub>IL</sub> (1)	Ports 0, 1, 2 Ports 7, 8 Ports 3, C $\overline{\text{RES}}$ PWM2, PWM3	Output disabled Pull-up resistor off V <sub>IN</sub> =V <sub>SS</sub> (Including output Tr's off leakage current)	2.2 to 5.5	-1			μA
	I <sub>IL</sub> (2)	XT1, XT2	For input port specification V <sub>IN</sub> =V <sub>SS</sub>	2.2 to 5.5	-1			
	I <sub>IL</sub> (3)	CF1	V <sub>IN</sub> =V <sub>SS</sub>	2.2 to 5.5	-15			
High level output voltage	V <sub>OH</sub> (1)	Ports 0, 1, 2 Ports 3, C	I <sub>OH</sub> =-1mA	4.5 to 5.5	V <sub>DD</sub> -1			V
	V <sub>OH</sub> (2)		I <sub>OH</sub> =-0.4mA	3.0 to 5.5	V <sub>DD</sub> -0.4			
	V <sub>OH</sub> (3)		I <sub>OH</sub> =-0.2mA	2.2 to 5.5	V <sub>DD</sub> -0.4			
	V <sub>OH</sub> (4)	Ports 71 to 73	I <sub>OH</sub> =-0.4mA	3.0 to 5.5	V <sub>DD</sub> -0.4			
	V <sub>OH</sub> (5)		I <sub>OH</sub> =-0.2mA	2.2 to 5.5	V <sub>DD</sub> -0.4			
	V <sub>OH</sub> (6)	PWM2, PWM3	I <sub>OH</sub> =-10mA	4.5 to 5.5	V <sub>DD</sub> -1.5			
	V <sub>OH</sub> (7)		I <sub>OH</sub> =-1.6mA	3.0 to 5.5	V <sub>DD</sub> -0.4			
	V <sub>OH</sub> (8)		I <sub>OH</sub> =-1mA	2.2 to 5.5	V <sub>DD</sub> -0.4			
Low level output voltage	V <sub>OL</sub> (1)	Ports 0, 1, 2 Ports 3, C PWM2, PWM3,	I <sub>OL</sub> =10mA	4.5 to 5.5			1.5	
	V <sub>OL</sub> (2)		I <sub>OL</sub> =1.6mA	3.0 to 5.5		0.4		
	V <sub>OL</sub> (3)		I <sub>OL</sub> =1mA	2.2 to 5.5		0.4		
	V <sub>OL</sub> (4)	Ports 7, 8 XT2	I <sub>OL</sub> =1.6mA	3.0 to 5.5		0.4		
	V <sub>OL</sub> (5)		I <sub>OL</sub> =1mA	2.2 to 5.5		0.4		
	V <sub>OL</sub> (6)	P00, P01	I <sub>OL</sub> =30mA	4.5 to 5.5		1.5		
	V <sub>OL</sub> (7)		I <sub>OL</sub> =5mA	3.0 to 5.5		0.4		
	V <sub>OL</sub> (8)		I <sub>OL</sub> =2.5mA	2.2 to 5.5		0.4		
Pull-up resistance	R <sub>pu</sub> (1)	Ports 0, 1, 2, 7 Ports 3, C	V <sub>OH</sub> =0.9V <sub>DD</sub>	4.5 to 5.5	15	35	80	kΩ
	R <sub>pu</sub> (2)			2.2 to 5.5	18	35	150	
Hysteresis voltage	V <sub>HYS</sub>	$\overline{\text{RES}}$ Ports 1, 2, 7		2.2 to 5.5		0.1V <sub>DD</sub>		V
Pin capacitance	CP	All pins	<ul style="list-style-type: none"> <li>• For pins other than that under test: V<sub>IN</sub>=V<sub>SS</sub></li> <li>• f=1MHz</li> <li>• Ta=25°C</li> </ul>	2.2 to 5.5		10		pF

# LC87F5M64A

**Serial I/O Characteristics** at Ta = -40°C to +85°C, V<sub>SS1</sub> = V<sub>SS2</sub> = V<sub>SS3</sub> = 0V

## 1. SIO0 Serial I/O Characteristics (Note 4-1-1)

Parameter		Symbol	Pins /Remarks	Conditions	V <sub>DD</sub> [V]	Specification						
						min	typ	max	unit			
Serial clock	Input clock	Frequency	tSCK(1)	SCK0(P12)	• See Fig. 6.	2.2 to 5.5	2			tCYC		
		Low level pulse width	tSCKL(1)				1					
		High level pulse width	tSCKH(1)				1					
			tSCKHA(1)									
	Output clock	Frequency	tSCK(2)	SCK0(P12)	• CMOS output selected • See Fig. 6.	2.2 to 5.5	4/3			tSCK		
		Low level pulse width	tSCKL(2)				1/2					
High level pulse width		tSCKH(2)	1/2									
		tSCKHA(2)										
Serial input	Data setup time	tsDI(1)	SB0(P11), SI0(P11)	• Must be specified with respect to rising edge of SIOCLK • See fig. 6.	2.2 to 5.5	0.03						
	Data hold time	thDI(1)				2.2 to 5.5	0.03					
Serial output	Input clock	Output delay time	tdD0(1)	SO0(P10), SB0(P11),	• Continuous data transmission/reception mode • (Note 4-1-3)	2.2 to 5.5			(1/3)tCYC +0.05	μs		
			tdD0(2)				• Synchronous 8-bit mode • (Note 4-1-3)	2.2 to 5.5				1tCYC +0.05
			tdD0(3)				• (Note 4-1-3)	2.2 to 5.5				

Note 4-1-1: These specifications are theoretical values. Add margin depending on its use.

Note 4-1-2: To use serial-clock-input in continuous trans/rec mode, a time from SIORUN being set when serial clock is "H" to the first negative edge of the serial clock must be longer than tSCKHA.

Note 4-1-3: Must be specified with respect to falling edge of SIOCLK. Must be specified as the time to the beginning of output state change in open drain output mode. See Fig. 6.

# LC87F5M64A

## 2. SIO1 Serial I/O Characteristics (Note 4-2-1)

Parameter		Symbol	Pins/ Remarks	Conditions	V <sub>DD</sub> [V]	Specification				
						min	typ	max	unit	
Serial clock	Input clock	Frequency	tSCK(3)	SCK1(P15)	• See Fig. 6.	2.2 to 5.5	2			tCYC
		Low level pulse width	tSCKL(3)				1			
		High level pulse width	tSCKH(3)				1			
	Output clock	Frequency	tSCK(4)	SCK1(P15)	• CMOS output selected. • See Fig. 6.	2.2 to 5.5	2			tSCK
		Low level pulse width	tSCKL(4)				1/2			
		High level pulse width	tSCKH(4)				1/2			
Serial input	Data setup time	tsDI(2)	SB1(P14), SI1(P14)	• Must be specified with respect to rising edge of SIOCLK. • See fig. 6.	2.2 to 5.5	0.03			μs	
	Data hold time	thDI(2)				0.03				
Serial output	Output delay time	tdD0(4)	SO1(P13), SB1(P14)	• Must be specified with respect to falling edge of SIOCLK. • Must be specified as the time to the beginning of output state change in open drain output mode. • See Fig. 6.	2.2 to 5.5			(1/3)tCYC +0.05	μs	

Note 4-2-1: These specifications are theoretical values. Add margin depending on its use.

# LC87F5M64A

## Pulse Input Conditions at Ta = -40°C to +85°C, VSS1 = VSS2 = VSS3 = 0V

Parameter	Symbol	Pins/Remarks	Conditions	Specification				
				V <sub>DD</sub> [V]	min	typ	max	unit
High/low level pulse width	tPIH(1) tPIL(1)	INT0(P70), INT1(P71), INT2(P72), INT4(P20 to P23), INT5(P24 to P27), INT6(P20), INT7(P24)	<ul style="list-style-type: none"> <li>Interrupt source flag can be set.</li> <li>Event inputs for timer 0 or 1 are enabled.</li> </ul>	2.2 to 5.5	1			tCYC
	tPIH(2) tPIL(2)	INT3(P73) when noise filter time constant is 1/1.	<ul style="list-style-type: none"> <li>Interrupt source flag can be set.</li> <li>Event inputs for timer 0 are enabled.</li> </ul>	2.2 to 5.5	2			
	tPIH(3) tPIL(3)	INT3(P73) when noise filter time constant is 1/32	<ul style="list-style-type: none"> <li>Interrupt source flag can be set.</li> <li>Event inputs for timer 0 are enabled.</li> </ul>	2.2 to 5.5	64			
	tPIH(4) tPIL(4)	INT3(P73) when noise filter time constant is 1/128	<ul style="list-style-type: none"> <li>Interrupt source flag can be set.</li> <li>Event inputs for timer 0 are enabled.</li> </ul>	2.2 to 5.5	256			
	tPIL(5)	$\overline{\text{RES}}$	Resetting is enabled.	2.2 to 5.5	200			

## AD Converter Characteristics at Ta = -40°C to +85°C, VSS1 = VSS2 = VSS3 = 0V

Parameter	Symbol	Pins/Remarks	Conditions	Specification				
				V <sub>DD</sub> [V]	min	typ	max	unit
Resolution	N	AN0(P80) to		3.0 to 5.5		8		bit
Absolute accuracy	ET	AN6(P86), AN8(P70), AN9(P71), AN10(XT1), AN11(XT2)	(Note 6-1)	3.0 to 5.5			±1.5	LSB
Conversion time	TCAD		AD conversion time=32×tCYC (when ADCR2=0) (Note 6-2)	4.5 to 5.5	11.74 (tCYC= 0.367μs)		97.92 (tCYC= 3.06μs)	μs
				3.0 to 5.5	23.53 (tCYC= 0.735μs)		97.92 (tCYC= 3.06μs)	
			AD conversion time=64×tCYC (when ADCR2=1) (Note 6-2)	4.5 to 5.5	15.68 (tCYC= 0.245μs)		97.92 (tCYC= 1.53μs)	
				3.0 to 5.5	23.49 (tCYC= 0.367μs)		97.92 (tCYC= 1.53μs)	
Analog input voltage range	VAIN			3.0 to 5.5	V <sub>SS</sub>		V <sub>DD</sub>	V
Analog port input current	I <sub>AINH</sub>		VAIN=V <sub>DD</sub>	3.0 to 5.5			1	μA
	I <sub>AINL</sub>		VAIN=V <sub>SS</sub>	3.0 to 5.5		-1		

Note 6-1: The quantization error (±1/2 LSB) is excluded from the absolute accuracy value.

Note 6-2: The conversion time refers to the interval from the time the instruction for starting the converter is issued till the time the complete digital value corresponding to the analog input value is loaded in the required register.

# LC87F5M64A

## Consumption Current Characteristics at Ta = -40°C to +85°C, V<sub>SS1</sub> = V<sub>SS2</sub> = V<sub>SS3</sub> = 0V

Parameter	Symbol	Pins/Remarks	Conditions	Specification				
				V <sub>DD</sub> [V]	min	typ	max	unit
Normal mode consumption current (Note 7-1)	IDDOP(1)	V <sub>DD1</sub> =V <sub>DD2</sub> =V <sub>DD3</sub>	<ul style="list-style-type: none"> <li>FmCF=12MHz ceramic oscillation mode</li> <li>FmX'tal=32.768kHz by crystal oscillation mode</li> <li>System clock set to 12MHz side</li> <li>Internal RC oscillation stopped</li> <li>frequency variable RC oscillation stopped</li> <li>1/1 frequency division ratio.</li> </ul>	4.5 to 5.5		9.1	18.5	mA
			<ul style="list-style-type: none"> <li>System clock set to 12MHz side</li> <li>Internal RC oscillation stopped</li> <li>frequency variable RC oscillation stopped</li> <li>1/1 frequency division ratio.</li> </ul>	2.8 to 4.5		5.3	13.5	
	<ul style="list-style-type: none"> <li>FmCF=8MHz ceramic oscillation mode</li> <li>FmX'tal=32.768kHz by crystal oscillation mode</li> <li>System clock set to 8MHz side</li> <li>Internal RC oscillation stopped</li> <li>frequency variable RC oscillation stopped</li> <li>1/1 frequency division ratio.</li> </ul>		4.5 to 5.5		6.7	14		
	<ul style="list-style-type: none"> <li>System clock set to 8MHz side</li> <li>Internal RC oscillation stopped</li> <li>frequency variable RC oscillation stopped</li> <li>1/1 frequency division ratio.</li> </ul>		2.5 to 4.5		3.8	10		
	<ul style="list-style-type: none"> <li>FmCF=4MHz ceramic oscillation mode</li> <li>FmX'tal=32.768kHz by crystal oscillation mode</li> <li>System clock set to 4MHz side</li> <li>Internal RC oscillation stopped</li> <li>frequency variable RC oscillation stopped</li> <li>1/2 frequency division ratio.</li> </ul>		4.5 to 5.5		2.7	6		
	<ul style="list-style-type: none"> <li>System clock set to 4MHz side</li> <li>Internal RC oscillation stopped</li> <li>frequency variable RC oscillation stopped</li> <li>1/2 frequency division ratio.</li> </ul>		2.2 to 4.5		1.45	3.8		
	<ul style="list-style-type: none"> <li>FmCF=0Hz (oscillation stopped)</li> <li>FmX'tal=32.768kHz by crystal oscillation mode</li> <li>System clock set to internal RC oscillation</li> <li>frequency variable RC oscillation stopped</li> <li>1/2 frequency division ratio.</li> </ul>		4.5 to 5.5		0.95	4.3		
	<ul style="list-style-type: none"> <li>System clock set to internal RC oscillation</li> <li>frequency variable RC oscillation stopped</li> <li>1/2 frequency division ratio.</li> </ul>		2.2 to 4.5		0.53	3.0		
	<ul style="list-style-type: none"> <li>FmCF=0Hz (oscillation stopped)</li> <li>FmX'tal=32.768kHz by crystal oscillation mode.</li> <li>System clock set to 1MHz with frequency variable RC oscillation</li> <li>Internal RC oscillation stopped</li> <li>1/2 frequency division ratio.</li> </ul>		4.5 to 5.5		1.25	5.2		
	<ul style="list-style-type: none"> <li>System clock set to 1MHz with frequency variable RC oscillation</li> <li>Internal RC oscillation stopped</li> <li>1/2 frequency division ratio.</li> </ul>		2.2 to 4.5		0.67	4.2		
	IDDOP(10)		<ul style="list-style-type: none"> <li>FmCF=0Hz (oscillation stopped)</li> <li>FmX'tal=32.768kHz by crystal oscillation mode.</li> <li>System clock set to 32.768kHz side.</li> <li>Internal RC oscillation stopped</li> <li>frequency variable RC oscillation stopped</li> <li>1/2 frequency division ratio.</li> </ul>	4.5 to 5.5		38	110	μA
IDDOP(11)	<ul style="list-style-type: none"> <li>System clock set to 32.768kHz side.</li> <li>Internal RC oscillation stopped</li> <li>frequency variable RC oscillation stopped</li> <li>1/2 frequency division ratio.</li> </ul>	2.2 to 4.5		19	70			
HALT mode consumption current (Note 7-1)	IDDHALT(1)	V <sub>DD1</sub> =V <sub>DD2</sub> =V <sub>DD3</sub>	<ul style="list-style-type: none"> <li>HALT mode</li> <li>FmCF=12MHz ceramic oscillation mode</li> <li>FmX'tal=32.768kHz by crystal oscillation mode</li> <li>System clock set to 12MHz side</li> <li>Internal RC oscillation stopped</li> <li>frequency variable RC oscillation stopped</li> <li>1/1 frequency division ratio.</li> </ul>	4.5 to 5.5		3.2	7.5	mA
			<ul style="list-style-type: none"> <li>System clock set to 12MHz side</li> <li>Internal RC oscillation stopped</li> <li>frequency variable RC oscillation stopped</li> <li>1/1 frequency division ratio.</li> </ul>	2.8 to 5.5		1.8	4	
	<ul style="list-style-type: none"> <li>HALT mode</li> <li>FmCF=8MHz ceramic oscillation mode</li> <li>FmX'tal=32.768kHz by crystal oscillation mode</li> <li>System clock set to 8MHz side</li> <li>Internal RC oscillation stopped</li> <li>frequency variable RC oscillation stopped</li> <li>1/1 frequency division ratio.</li> </ul>		4.5 to 5.5		2.4	5.3		
IDDHALT(3)	<ul style="list-style-type: none"> <li>System clock set to 8MHz side</li> <li>Internal RC oscillation stopped</li> <li>frequency variable RC oscillation stopped</li> <li>1/1 frequency division ratio.</li> </ul>	2.5 to 4.5		12.5	2.8			

Note 7-1: The consumption current value includes none of the currents that flow into the output Tr and internal pull-up resistors

Continued on next page.



# LC87F5M64A

Continued from preceding page.

Parameter	Symbol	Pins/Remarks	Conditions	Specification				
				V <sub>DD</sub> [V]	min	typ	max	unit
HALT mode consumption current (Note 7-1)	IDDHALT(4)	V <sub>DD1</sub> =V <sub>DD2</sub> =V <sub>DD3</sub>	<ul style="list-style-type: none"> <li>• HALT mode</li> <li>• FmCF=4MHz ceramic oscillation mode</li> <li>• FmX'tal=32.768kHz by crystal oscillation mode</li> </ul>	4.5 to 5.5		1	2.3	mA
	IDDHALT(5)		<ul style="list-style-type: none"> <li>• System clock set to 4MHz side</li> <li>• Internal RC oscillation stopped</li> <li>• frequency variable RC oscillation stopped</li> <li>• 1/2 frequency division ratio.</li> </ul>	2.2 to 4.5		0.5	1.3	
	IDDHALT(6)		<ul style="list-style-type: none"> <li>• HALT mode</li> <li>• FmCF=0Hz (oscillation stopped)</li> <li>• FmX'tal=32.768kHz by crystal oscillation mode</li> </ul>	4.5 to 5.5		0.33	0.9	
	IDDHALT(7)		<ul style="list-style-type: none"> <li>• System clock set to internal RC oscillation</li> <li>• frequency variable RC oscillation stopped</li> <li>• 1/2 frequency division ratio.</li> </ul>	2.2 to 4.5		0.17	0.7	
	IDDHALT(8)		<ul style="list-style-type: none"> <li>• HALT mode</li> <li>• FmCF=0Hz (oscillation stopped)</li> <li>• FmX'tal=32.768kHz by crystal oscillation mode.</li> </ul>	4.5 to 5.5		1	3.8	
	IDDHALT(9)		<ul style="list-style-type: none"> <li>• System clock set to 1MHz with frequency variable RC oscillation</li> <li>• Internal RC oscillation stopped</li> <li>• 1/2 frequency division ratio.</li> </ul>	2.2 to 4.5		0.5	2.7	
	IDDHALT(10)		<ul style="list-style-type: none"> <li>• HALT mode</li> <li>• FmCF=0Hz (oscillation stopped)</li> <li>• FmX'tal=32.768kHz by crystal oscillation mode.</li> </ul>	4.5 to 5.5		18	70	μA
IDDHALT(11)	<ul style="list-style-type: none"> <li>• System clock set to 32.768kHz side.</li> <li>• Internal RC oscillation stopped</li> <li>• frequency variable RC oscillation stopped</li> <li>• 1/2 frequency division ratio.</li> </ul>	2.2 to 4.5		5	63			
HOLD mode consumption current	IDDHOLD(1)	V <sub>DD1</sub>	<ul style="list-style-type: none"> <li>• HOLD mode</li> <li>• CF1=V<sub>DD</sub> or open (External clock mode)</li> </ul>	4.5 to 5.5		0.03	18	μA
	IDDHOLD(2)		<ul style="list-style-type: none"> <li>• Timer HOLD mode</li> <li>• CF1=V<sub>DD</sub> or open (External clock mode)</li> </ul>	2.2 to 4.5		0.01	14	
Timer HOLD mode consumption current	IDDHOLD(3)		<ul style="list-style-type: none"> <li>• FmX'tal=32.768kHz by crystal oscillation mode</li> </ul>	4.5 to 5.5		16	63	
	IDDHOLD(4)		<ul style="list-style-type: none"> <li>• FmX'tal=32.768kHz by crystal oscillation mode</li> </ul>	2.2 to 4.5		3.5	50	

Note 7-1: The consumption current value includes none of the currents that flow into the output Tr and internal pull-up resistors

## F-ROM Programming Characteristics at Ta = +10°C to +55°C, V<sub>SS1</sub> = V<sub>SS2</sub> = V<sub>SS3</sub> = 0V

Parameter	Symbol	Pins/Remarks	Conditions	Specification				
				V <sub>DD</sub> [V]	min	typ	max	unit
Onboard programming current	IDDFW(1)	V <sub>DD1</sub>	<ul style="list-style-type: none"> <li>• Without CPU current</li> </ul>	2.7 to 5.5		5	10	mA
Programming time	tFW(1)		<ul style="list-style-type: none"> <li>• Erasing</li> </ul>	2.7 to 5.5		20	30	ms
	tFW(2)		<ul style="list-style-type: none"> <li>• programming</li> </ul>	2.7 to 5.5		40	60	μs

# LC87F5M64A

## UART (Full Duplex) Operating Conditions at $T_a = -40^{\circ}\text{C}$ to $+85^{\circ}\text{C}$ , $V_{SS1} = V_{SS2} = V_{SS3} = 0\text{V}$

Parameter	Symbol	Pins/Remarks	Conditions	Specification				
				$V_{DD}[\text{V}]$	min	typ	max	unit
Transfer rate	UBR	P32 (UTX1), P33 (URX1), P34 (UTX2), P35 (URX2)		2.5 to 5.5	16/3		8192/3	tCYC

Data length : 7, 8, and 9 bits (LSB first)

Stop bits : 1-bit (2-bit in continuous data transmission)

Parity bits : None

Example of Continuous 8-bit Data Transmission Mode Processing (First Transmit Data = 55H)

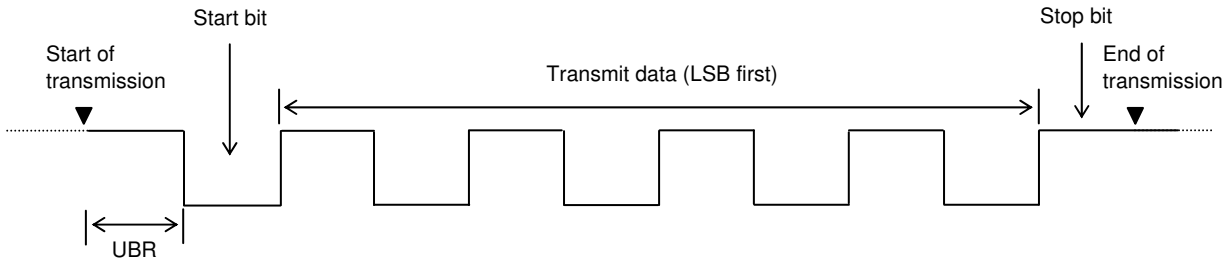

Example of Continuous 8-bit Data Reception Mode Processing (First Receive Data = 55H)

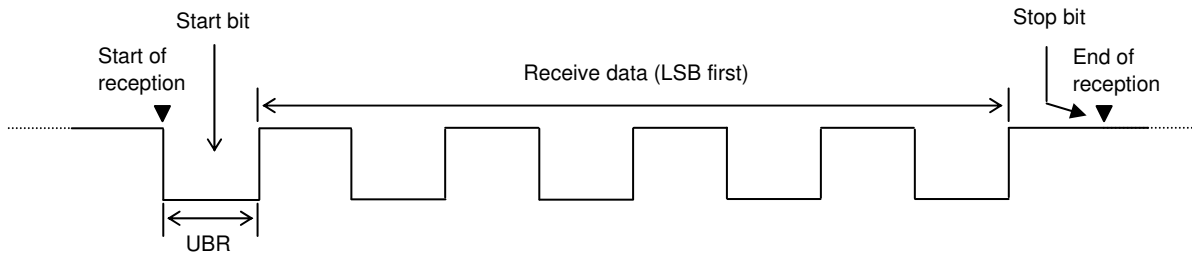

## VDD1, VSS1 Terminal Condition

It is necessary to place capacitors between  $V_{DD1}$  and  $V_{SS1}$  as describe below.

- Place capacitors as close to  $V_{DD1}$  and  $V_{SS1}$  as possible.
- Place capacitors so that the length of each terminal to the each leg of the capacitor be equal ( $L1 = L1'$ ,  $L2 = L2'$ ).
- Place high capacitance capacitor  $C1$  and low capacitance capacitor  $C2$  in parallel.
- Capacitance of  $C2$  must be more than  $0.1\mu\text{F}$ .
- Use thicker pattern for  $V_{DD1}$  and  $V_{SS1}$ .

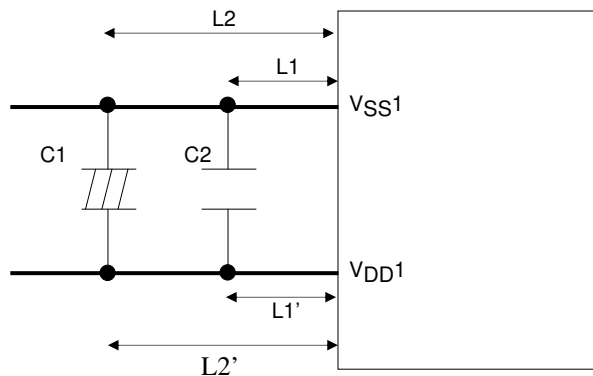

# LC87F5M64A

## Characteristics of a Sample Main System Clock Oscillation Circuit

Given below are the characteristics of a sample main system clock oscillation circuit that are measured using a Our designated oscillation characteristics evaluation board and external components with circuit constant values with which the oscillator vendor confirmed normal and stable oscillation.

Table 1 Characteristics of a Sample Main System Clock Oscillator Circuit with a Ceramic Oscillator

Nominal Frequency	Vendor Name	Oscillator Name	Circuit Constant				Operating Voltage Range [V]	Oscillation Stabilization Time		Remarks
			C1 [pF]	C2 [pF]	Rf1 [Ω]	Rd1 [Ω]		typ [ms]	max [ms]	
12MHz	MURATA	CSTCE12M0G52-R0	(10)	(10)	Open	470	2.6 to 5.5	0.03	0.5	Internal C1,C2
10MHz		CSTCE10M0G52-R0	(10)	(10)	Open	470	2.4 to 5.5	0.03	0.5	Internal C1,C2
		CSTLS10M0G53-B0	(15)	(15)	Open	680	2.6 to 5.5	0.03	0.5	Internal C1,C2
8MHz		CSTCE8M00G52-R0	(10)	(10)	Open	680	2.3 to 5.5	0.03	0.5	Internal C1,C2
		CSTLS8M00G53-B0	(15)	(15)	Open	1k	2.5 to 5.5	0.03	0.5	Internal C1,C2
4MHz		CSTCR4M00G53-R0	(15)	(15)	Open	1.5k	2.2 to 5.5	0.03	0.5	Internal C1,C2
		CSTLS4M00G53-B0	(15)	(15)	Open	1.5k	2.2 to 5.5	0.03	0.5	Internal C1,C2

The oscillation stabilization time refers to the time interval that is required for the oscillation to get stabilized after  $V_{DD}$  goes above the operating voltage lower limit (see Fig. 4).

## Characteristics of a Sample Subsystem Clock Oscillator Circuit

Given below are the characteristics of a sample subsystem clock oscillation circuit that are measured using a Our designated oscillation characteristics evaluation board and external components with circuit constant values with which the oscillator vendor confirmed normal and stable oscillation.

Table 2 Characteristics of a Sample Subsystem Clock Oscillator Circuit with a Crystal Oscillator

Nominal Frequency	Vendor Name	Oscillator Name	Circuit Constant				Operating Voltage Range [V]	Oscillation Stabilization Time		Remarks
			C3 [pF]	C4 [pF]	Rf2 [Ω]	Rd2 [Ω]		typ [s]	max [s]	
32.768kHz	EPSON TOYOCOM	MC-306	18	18	Open	560k	2.2 to 5.5	1.2	3.0	Applicable CL value=12.5pF

The oscillation stabilization time refers to the time interval that is required for the oscillation to get stabilized after the instruction for starting the subclock oscillation circuit is executed and to the time interval that is required for the oscillation to get stabilized after the HOLD mode is reset (see Figure. 4).

Note: The components that are involved in oscillation should be placed as close to the IC and to one another as possible because they are vulnerable to the influences of the circuit pattern.

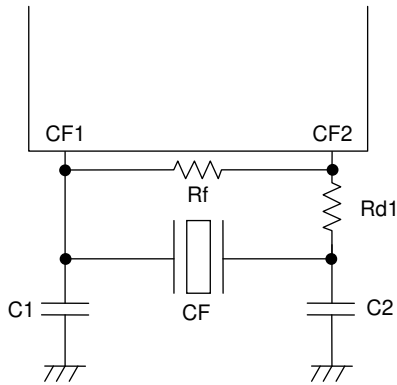

Figure 1 CF Oscillator Circuit

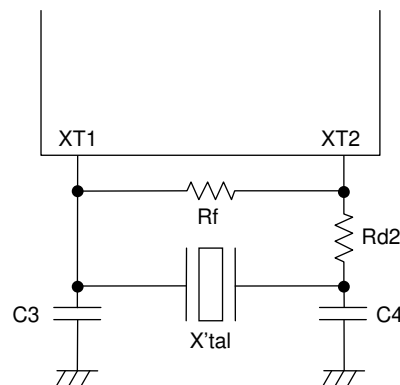

Figure 2 XT Oscillator Circuit

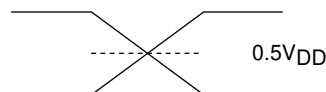
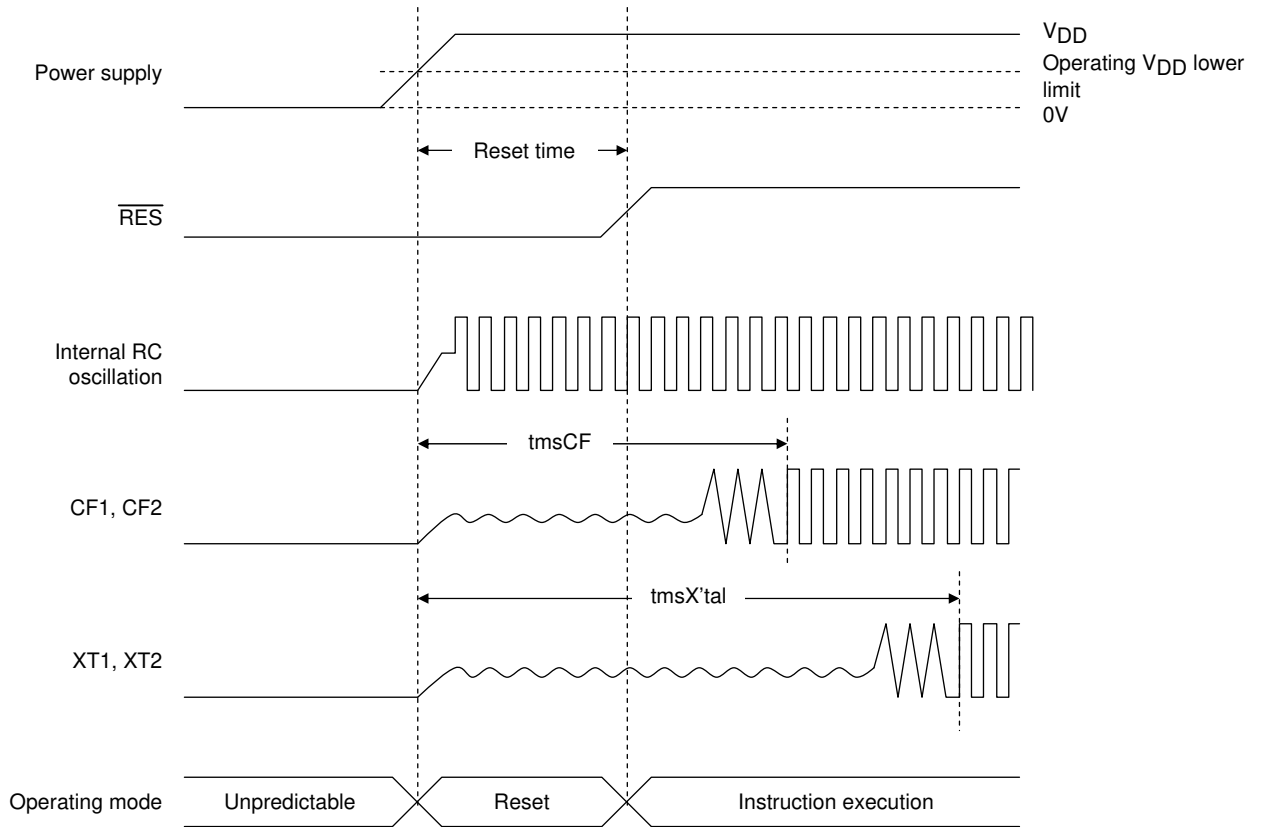
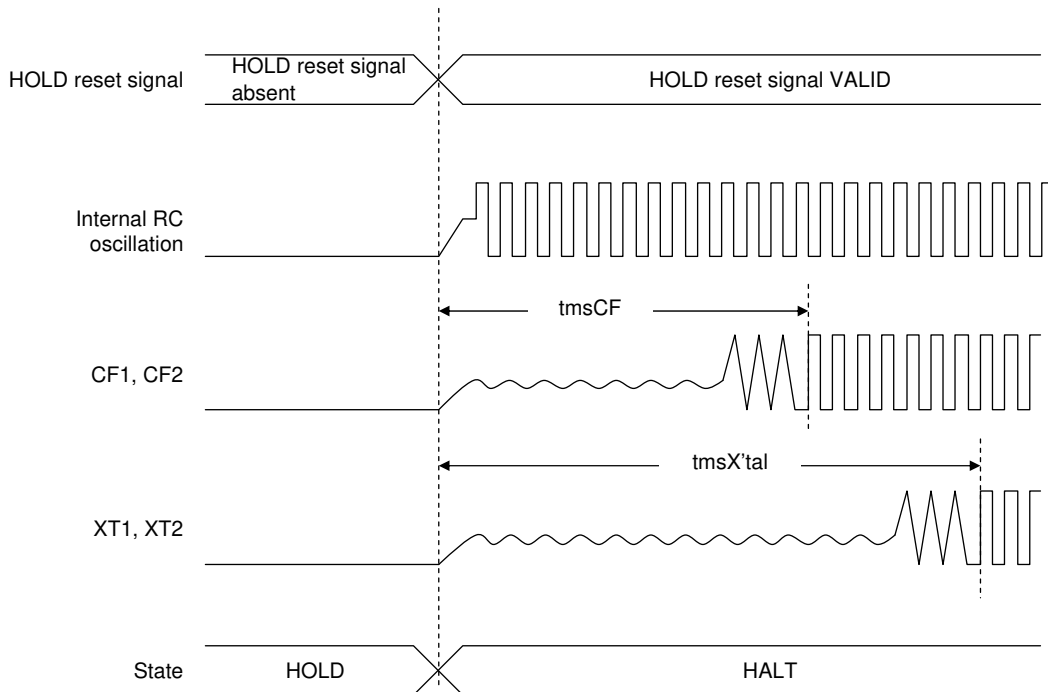

Figure 3 AC Timing Measurement Point

# LC87F5M64A



## Reset Time and Oscillation Stabilization Time



## HOLD Release Signal and Oscillation Stabilization Time

Figure 4 Oscillation Stabilization Times

# LC87F5M64A

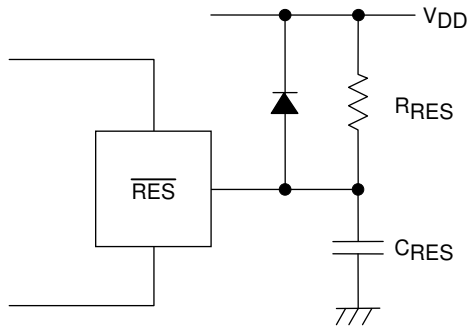

Note:

Determine the value of  $C_{RES}$  and  $R_{RES}$  so that the reset signal is present for a period of  $200\mu s$  after the supply voltage goes beyond the lower limit of the IC's operating voltage.

Figure 5 Reset Circuit

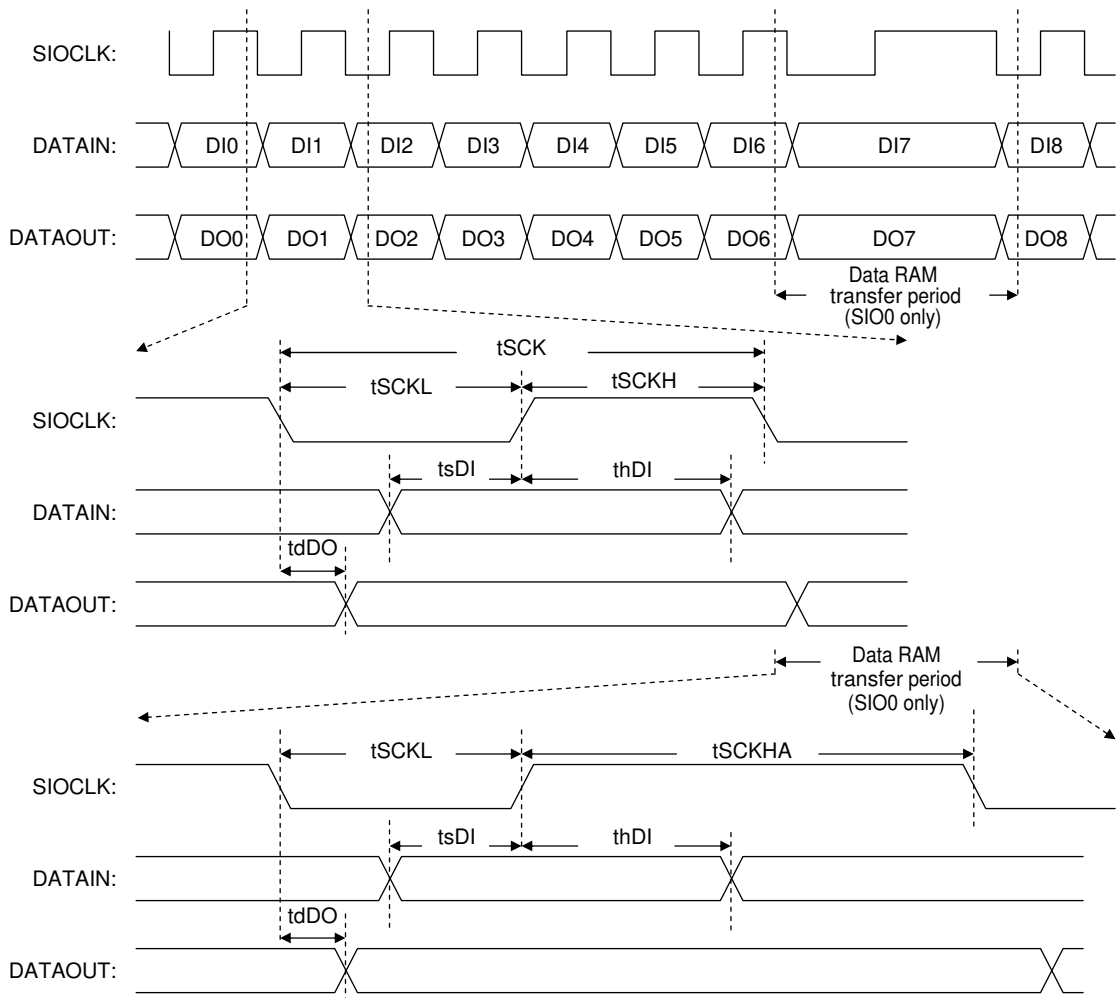

Figure 6 Serial I/O Waveforms

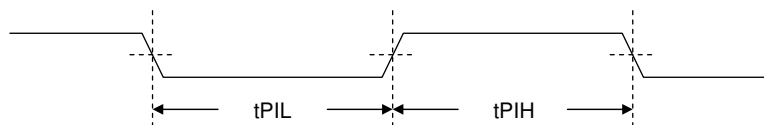

Figure 7 Pulse Input Timing Signal Waveform

ON Semiconductor and the ON logo are registered trademarks of Semiconductor Components Industries, LLC (SCILLC). SCILLC owns the rights to a number of patents, trademarks, copyrights, trade secrets, and other intellectual property. A listing of SCILLC's product/patent coverage may be accessed at [www.onsemi.com/site/pdf/Patent-Marking.pdf](http://www.onsemi.com/site/pdf/Patent-Marking.pdf). SCILLC reserves the right to make changes without further notice to any products herein. SCILLC makes no warranty, representation or guarantee regarding the suitability of its products for any particular purpose, nor does SCILLC assume any liability arising out of the application or use of any product or circuit, and specifically disclaims any and all liability, including without limitation special, consequential or incidental damages. "Typical" parameters which may be provided in SCILLC data sheets and/or specifications can and do vary in different applications and actual performance may vary over time. All operating parameters, including "Typicals" must be validated for each customer application by customer's technical experts. SCILLC does not convey any license under its patent rights nor the rights of others. SCILLC products are not designed, intended, or authorized for use as components in systems intended for surgical implant into the body, or other applications intended to support or sustain life, or for any other application in which the failure of the SCILLC product could create a situation where personal injury or death may occur. Should Buyer purchase or use SCILLC products for any such unintended or unauthorized application, Buyer shall indemnify and hold SCILLC and its officers, employees, subsidiaries, affiliates, and distributors harmless against all claims, costs, damages, and expenses, and reasonable attorney fees arising out of, directly or indirectly, any claim of personal injury or death associated with such unintended or unauthorized use, even if such claim alleges that SCILLC was negligent regarding the design or manufacture of the part. SCILLC is an Equal Opportunity/Affirmative Action Employer. This literature is subject to all applicable copyright laws and is not for resale in any manner.