



iCE40 UltraPlus Mobile Development Platform

Evaluation Board User Guide

FPGA-EB-02007 Version 1.2

October 2018

Contents

1.	Introduction	4
2.	Features	5
3.	Power and Battery	8
3.1.	Power Source	8
3.2.	Current Measurement Test Points	8
3.3.	Battery Management and 4.2 V Regulator	8
4.	Clock Sources	9
5.	Software Requirements	10
6.	Demonstrations	11
6.1.	Mobile Display Demonstration on U1	11
6.2.	Audio Microphone Demonstrations on U2	11
6.3.	RGB LED Demonstration on U3	11
6.4.	Sensor Demonstrations on U3	12
6.5.	Face Recognition Demonstration on U4	12
7.	Board Configuration and Programming	14
7.1.	Jumpers and Switches	14
7.2.	Programming the iCE40 Devices Configuration Memory (CRAM)	17
7.3.	Programming Onboard SPI Flash	18
8.	Communication Channels	20
8.1.	USB	20
8.2.	Bluetooth	20
9.	Ordering Information	20
10.	PCB Revision History	20
	References	21
	Standards Documents	21
	Lattice Semiconductor Documents	21
	Technical Support Assistance	21
	Appendix A. iCE40 UltraPlus Mobile Development Board Schematics	22
	Appendix B. iCE40 UltraPlus Mobile Development Board Bill of Materials	36
	Accessories	42
	Revision History	43

Figures

Figure 2.1. iCE40 UltraPlus Mobile Development Platform Board (Top Side)	6
Figure 2.2. iCE40 UltraPlus Mobile Development Platform Board (Bottom Side)	7
Figure 3.1. Power Block Diagram	8
Figure 4.1. Clock Sources for the iCE40 UltraPlus MDP Board	9
Figure 6.1. Rework Resistor Positions Described in Parallel Video Bus Configuration	13
Figure 7.1. Board Configuration for Programming iCE40 UltraPlus Device “U1”	15
Figure 7.2. Programming iCE40 Devices on Board	17
Figure 7.3. Programming SPI Flash on Board	18
Figure A.1. Block Diagram	22
Figure A.2. iCE40UP5K FPGA A - Display	23
Figure A.3. iCE40UP5K FPGA B - Audio	24
Figure A.4. iCE40UP5K FPGA C - Sensor	25
Figure A.5. iCE40UP5K FPGA D - Camera	26
Figure A.6. Common Components- SPI	27
Figure A.7. Display Circuitry	28
Figure A.8. Audio Circuitry	29
Figure A.9. Sensor & RGB Circuitry	30
Figure A.10. Camera Circuitry	31
Figure A.11. USB Programming	32
Figure A.12. Power Supplies	33
Figure A.13. Common Components	34
Figure A.14. Battery Connector & Charger	35

Tables

Table 7.1. iCE40 UltraPlus Device Selection	14
Table 7.2. iCE40 UltraPlus Device Selection Summary	16

1. Introduction

Thank you for choosing the Lattice iCE40 UltraPlus™ Mobile Development Platform (MDP) Board.

This MDP board is an easy-to-use platform for demonstrating various features of the iCE40 UltraPlus for mobile applications. The MDP form-factor is similar to a mobile device (cell phone), with various sensors, display, Bluetooth communication, and others. The board contains four individual iCE40 UltraPlus devices, each configured with a unique set of interfaces to support multiple demonstrations.

Features that can be demonstrated using this board include:

- Mobile Display (Onboard 1.54 inch 240 x 240 RGB wearable type display with MIPI DSI interface)
- Camera (Onboard VGA 640 x 480 sensor with CSI and parallel video interface option)
 - Image and facial recognition
- Microphones (Onboard Dual I2S and Dual PDM microphones with audio amp, 3.5 mm and expansion connectors)
 - Voice recognition
 - Audio beam forming capabilities
- Sensors (Various Mobile Type Sensors with expansion connector)
 - RGB LED
 - Pressure Sensor
 - Compass Sensor
 - Gyroscope Sensor
 - Accelerometer Sensor

This guide describes how to begin using the MDP. The contents of this user guide include top-level functional descriptions of the various portions of the evaluation board, a summary of demonstrations, descriptions of the onboard connectors, switches, jumpers, configuration options, along with a complete set of schematics and the bill of materials.

Note: Static electricity can severely shorten the lifespan of electronic components. Be careful to follow proper ESD prevention handling standards when handling and using the iCE40 UltraPlus Mobile Development Platform Board.

2. Features

The iCE40 UltraPlus Mobile Development Platform development kit includes the items below.

- iCE40 UltraPlus Mobile Development Platform– PCB, case, and integrated Li-ion battery featuring:
 - Four iCE40 UltraPlus devices (U1-U4 iCE40UP5K-UWG30) in 30-Ball WLCSP packages
 - Large capacity of onboard SPI Flash memory (U37 Micron M25P80 8Mb) to store the FPGA demo bitstream for all four iCE40 UltraPlus devices
 - Example of a PCB design using 0.40 mm Ball Pitch package
 - Control switches to select which of the four devices is active (only one device is active at a time)
 - Standard USB cable for device programming (Lattice part number HW-USBN-2A, HW-USBN-2B or equivalent)
 - RoHS-compliant packaging and process
- Key Components
 - iCE40UP5K-UWG30 (4 pieces)
 - Power Regulation
 - Bluetooth module
 - MIPI LCD Mobile Display (1.54 inch 240 x 240 RGB LH154Q01)
 - Camera image sensor OVM7692 VGA 640 x 480 (CSI and parallel video interface option)
 - Microphones (Dual I2S and Dual PDM microphones with audio amp, connectors for 3.5 mm and expansion)
 - RGB LED
 - Sensors that include:
 - Barometric pressure sensor
 - Compass sensor
 - 3D accelerometer and 3D gyroscope sensor
 - Three-axis linear accelerometer sensor
- Pre-loaded Demo – The kit includes a pre-loaded MIPI LCD Mobile Display demo.
- USB Connector Cable – A mini-B USB port provides power, a programming interface and communication channel for a PC to communicate directly to iCE40 devices.

Figure 2.1 shows the top side while Figure 2.2 on the next page shows the bottom side of the iCE40 UltraPlus Mobile Development Platform Board indicating the specific features that are designed on the board.

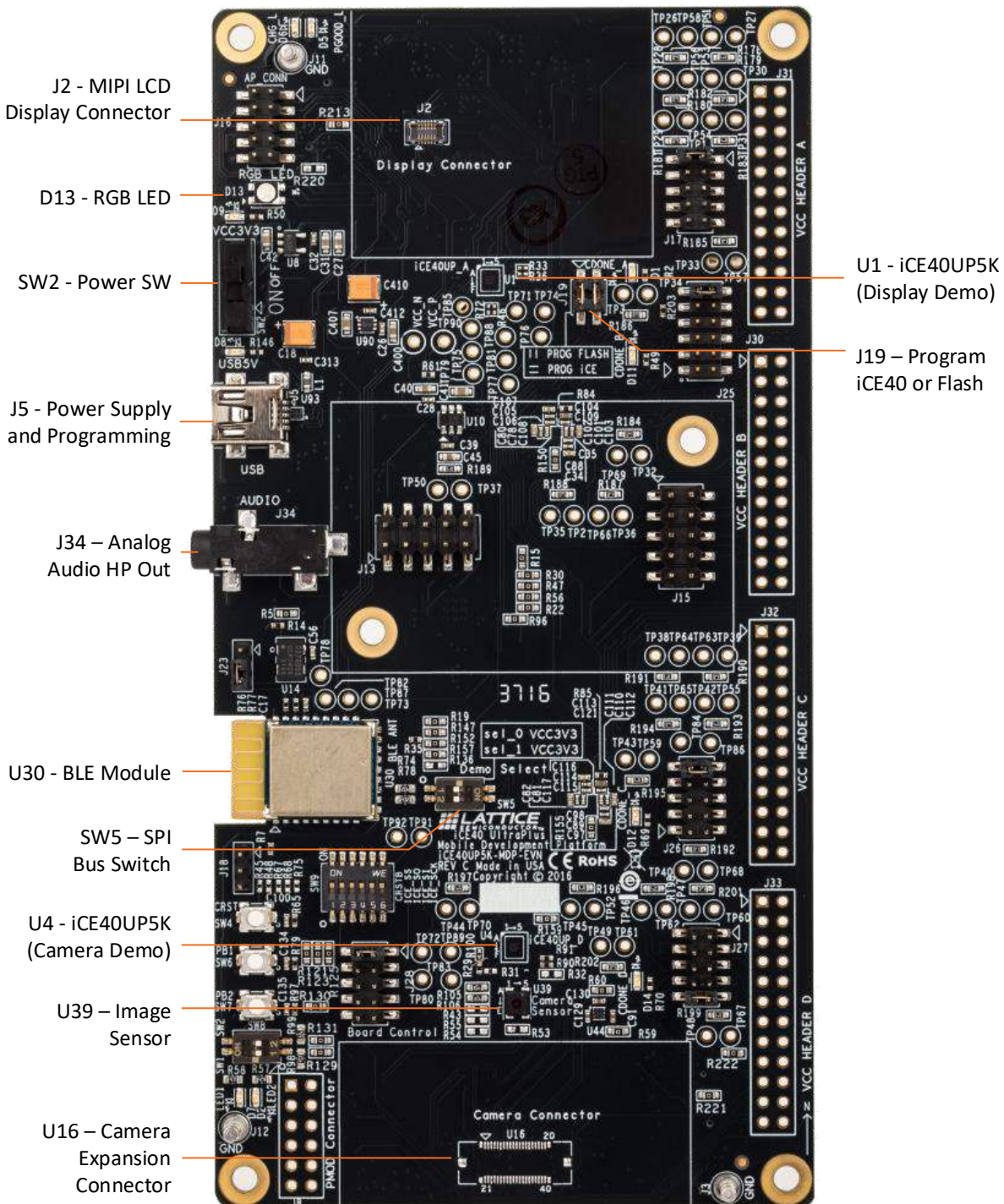

Figure 2.1. iCE40 UltraPlus Mobile Development Platform Board (Top Side)

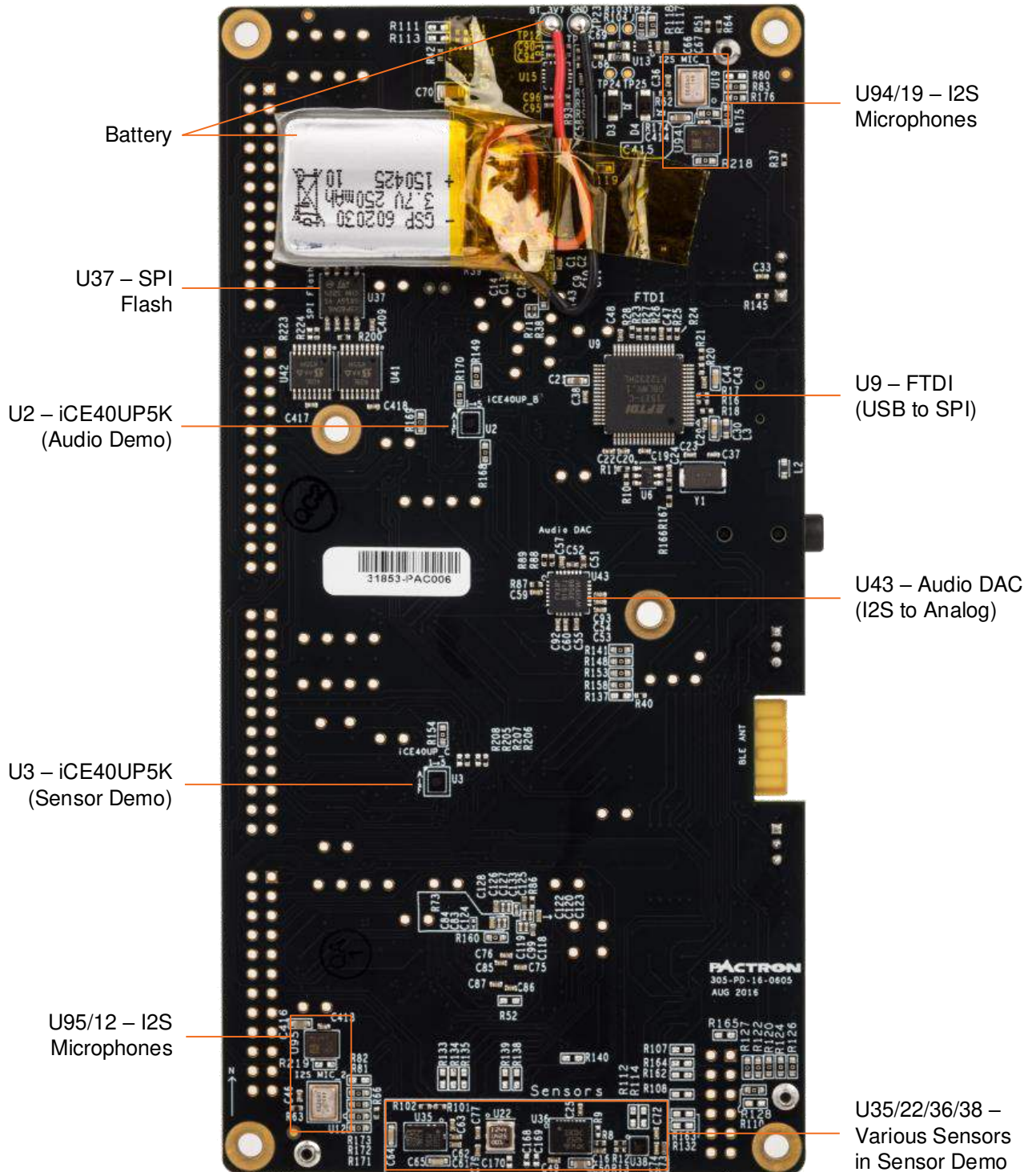

Figure 2.2. iCE40 UltraPlus Mobile Development Platform Board (Bottom Side)

3. Power and Battery

3.1. Power Source

The MDP board can be powered by three sources:

- External USB Connector J5 (5 V). Green LED D8 and Yellow LED D5 lights up when power is supplied.
- External AP Header Connector J16-8 (5 V) and J16-9 (GND). Yellow LED D5 lights up when power is supplied.
- Internal 250 mA Li-ion battery contained internal to the MDP case.

External power from USB connector J5 and AP header connector J16 are 'Diode-ORd'. If power is supplied to both connectors, the higher voltage powers the board. When external power is not supplied, the internal Li-ion battery contained in the case powers the board.

Power switch SW2 turns the board ON and OFF by enabling/disabling the main voltage regulator outputs of 3.3 V, 2.5 V, and 1.2 V. Green LED D9 lights up when the 3.3 V rail is active and indicates that the board is powered ON.

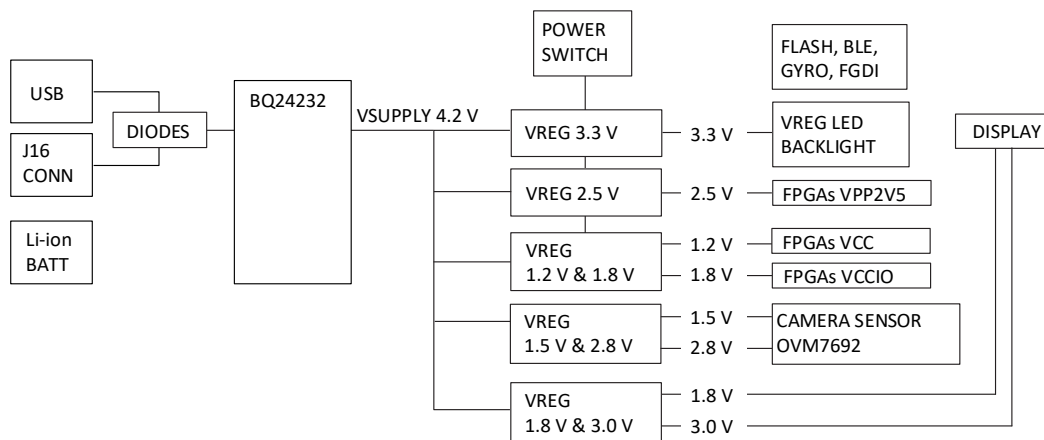

Figure 3.1. Power Block Diagram

3.2. Current Measurement Test Points

Each of the four FPGAs have six 1 Ω resistors in series with their power inputs to allow easy current measurements using a voltmeter and to ease reworking VCCIO voltage rails. See [Appendix A. iCE40 UltraPlus Mobile Development Board Schematics](#) for details.

3.3. Battery Management and 4.2 V Regulator

Chip BQ24232 U15 provides automatic battery management and the board's 4.2 V regulated voltage rail. The 4.2 V rail (VSUPPLY) is used to generate all of the board's other voltages. The management chip is always ON (not controlled by power switch SW2).

When external power is not available, the management chip uses the 250 mA Li-ion battery internal to MDP case to generate the 4.2 V rail.

When external 5 V is supplied (4.6 V to 6.0 V), the battery is automatically charged as required. The Green LED D6 lights during charging and turns OFF when charging is complete. Additionally, external power is used to generate the 4.2 V rail. The BQ24232 battery charging is configured with external resistors.

Default resistor configuration:

- 500 mA input current limit
- 200 mA charging current
- 25 mA end of charging termination current threshold
- 5-hour fast charge time and 30-minute pre-charge

4. Clock Sources

A 27 MHz oscillator is built on the Mobile Development Platform board. External clock input can also be provided to this board depending on the J23 settings.

There are six devices sharing the same clock source that are available at the same time. These include four iCE40UP5K-UWG30 (U1~U4) devices that are responsible for various demos, U43 which is a stereo audio DAC with direct drive headphone amplifier, and U39 which is an ultra-compact size 640 x 480 image sensor.

Short Pins 2-3 leads the onboard 27 MHz clock to these devices and provides external clock source through Pin 2 and Pin 3 (GND).

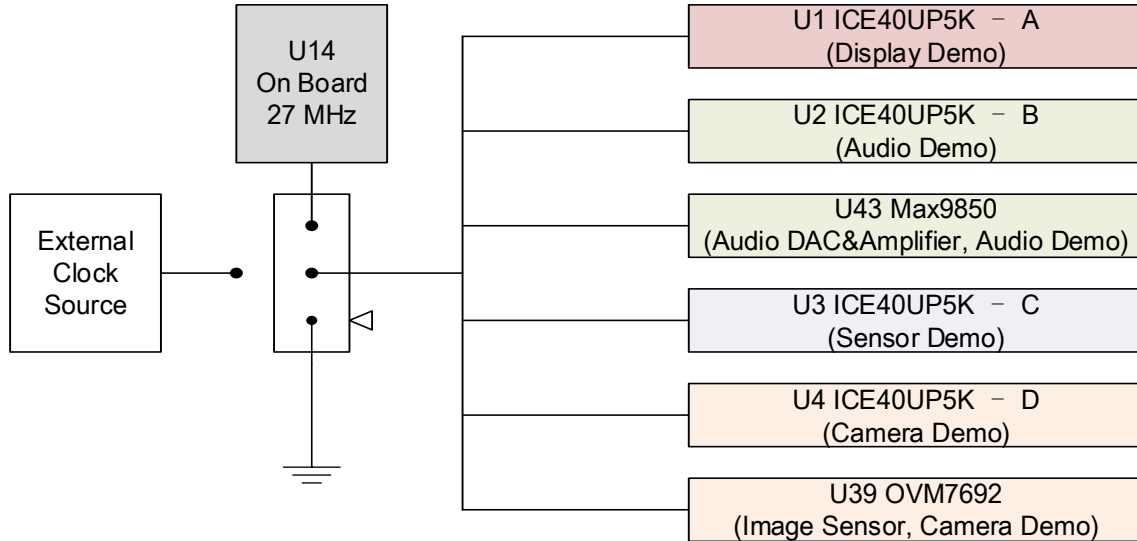

Figure 4.1. Clock Sources for the iCE40 UltraPlus MDP Board

5. Software Requirements

Install the following software before you begin developing designs for the board:

- Lattice iCEcube2 2017.01 (or higher)
Used for developing your own custom designs for the iCE40 UltraPlus FPGA.
- Diamond Programmer® 3. 8 (or higher)
Used to program the iCE40 UltraPlus FPGA.

These software programs are available at the www.latticesemi.com/software. Make sure you log in to www.latticesemi.com, otherwise these software downloads will not be visible.

6. Demonstrations

Four iCE40UP5K-UWG30 (U1-U4) devices are used on the Mobile Development Platform board. The devices are responsible for specific demonstrations. Lattice provides separate user guides that describe each demo in detail. The documents cover board configuration and step-by-step instructions. Please refer to the relevant documents for more details.

The following sections describe the Mobile Development Platform board demos.

6.1. Mobile Display Demonstration on U1

This demo showcases the ability of iCE40 UltraPlus to drive a small wearable display and buffer one full image frame.

Key components for this demo include:

- U1 iCE40UP5K-UWG30
- J2 Display connector for MIPI LCD display (MIPI LCD Display, 1.4" LH154Q01 is included in the kit.)
- U11 Display backlight driver
- U13 1.8 V and 3.0 V voltage regulator

Note: Be careful with the LCD display ribbon, it is fragile and can be damaged!

6.2. Audio Microphone Demonstrations on U2

FPGA U2 is optimized for microphone related demonstrations, such as audio beam. The board contains two I2S microphones, two PDM microphones, a 3.5 mm audio jack driven by a MAX9850 headphone audio amplifier, and an expansion connector allowing up to seven microphones used in an array. This demo shows the capability of picking up human voice and driving the output on the speaker with the same quality, irrespective of where the voice is originating from within a room.

Key components for this demo include:

- U2 iCE40UP5K-UWG30
- U12/U19 I2S omnidirectional microphone with Bottom Port and Analog Output
- U94/U95 PDM omnidirectional microphone with Bottom Port and Analog Output
- U43 Audio DAC with headphone amplifier.
- J34 3.5 mm audio jack for analog output
- J15 Expansion connector supporting up to seven microphones.
- J25 Header used to configure FPGA to microphone connections

6.3. RGB LED Demonstration on U3

This demo showcases the capability of ICE40-UltraPlus to control and drive an RGB LED. A mobile app software GUI tool is provided to allow a user to remotely control the LED via a phone or tablet over Bluetooth. The features of the demo include:

- Ability to control the color of the LED from a color palette.
- Ability to control the brightness of the LED.
- Ability to control the ON/OFF time of the LED – thereby creating a pulsating breathing effect.

Key components for this demo include:

- U3 iCE40UP5K-UWG30
- D13 RGB LED
- U30 Bluetooth Module used for remote control

It is recommended to download the RGB LED software GUI which interfaces with the MDP. This GUI allows you to control the RGB LED for color, brightness, blinking and 'breathing'. Download the PC or MAC version of the GUI at www.latticesemi.com/ice40ultraplusmdp.

6.4. Sensor Demonstrations on U3

This demo showcases the capability of iCE40 UltraPlus to act as a sensor hub.

Key components for this demo include:

- U3 iCE40UP5K-UWG30
- U22 Digital barometric pressure sensor
- U35 High performance e-compass 3D accelerometer and 3D magnetometer
- U36 3D accelerometer and 3D gyroscope
- U38 3-axis "pico" accelerometer

6.5. Face Recognition Demonstration on U4

This demo showcases the capability of ICE40-UltraPlus to detect and react to a general human face.

Key components for this demo include:

- U4 iCE40UP5K-UWG30
- U39 Image Sensor OVM7692
- U16 Camera Expansion Connector
- U44 1.5 V and 2.8 V voltage regulator

This demo uses the VGA (640 x 480) sensor OVM7692 U39 or the camera expansion connector U16. The default interface uses CSI2, however, the interface can be configured for 3.3 V parallel video interface to support the facial recognition demo with the following rework:

1. Remove resistors: R15, R29, R30, R47, R73, R90, R91, R100, R125, R126, R127, R142, R143, R149, R150, R154, R155.
2. Install 0 Ω resistors (or short with solder blob): R31, R32, R43, R52, R53, R54, R55, R56.
3. Verify resistors installed: R22, R159, R160.
4. If using Xtal U14 as clock source Jumper J23-2 and 3 else J23-2 should be open.

Figure 6.1 shows the resistors of the rework. Resistors highlighted in red rectangle need to be removed; resistors highlighted in green rectangle need to install 0 Ω resistors; blue highlights show the resistors needing installation verification.

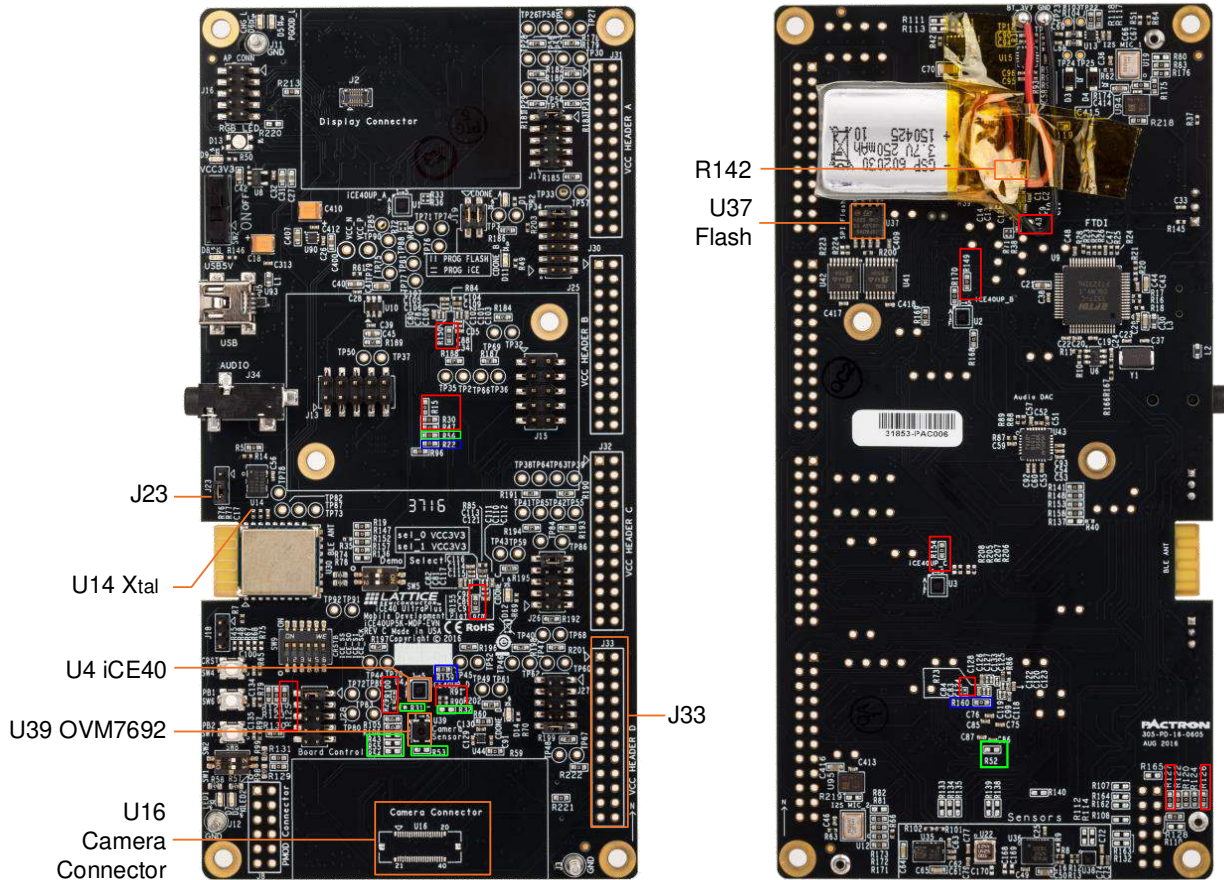

Figure 6.1. Rework Resistor Positions Described in Parallel Video Bus Configuration

7. Board Configuration and Programming

The iCE40 UltraPlus Mobile Development Board has four iCE40 devices. Each device serves specific demo purposes. As there is only one USB to SPI bridge chip used onboard, programming different iCE40 devices can be completed using combinations of jumper and switch settings. The installed jumpers used on the MDP board have a 2 mm pin-pitch, not the standard 100-mil style.

7.1. Jumpers and Switches

The iCE40 UltraPlus Mobile Development Board has the following jumpers:

- **J19**
Set these for either SPI Flash programming (both vertical) or SRAM (iCE40) programming (both horizontal), per the silkscreen markings on the board.
- **J17**
To program the iCE40 UltraPlus device U1, short pins 1-2. To program any other device on the board, short pins 9-10.
Note: Follow the silkscreen markings on the board, pins 1-2 are at the top of this header bank.
- **J25**
To program the iCE40 UltraPlus device U2, short pins 1-2. To program any other device on the board, short pins 11-12.
Note: Follow the silkscreen markings on the board, pins 1-2 are at the bottom of this header bank.
- **J26**
To program the iCE40 UltraPlus device U3, short pins 1-2. To program any other device on the board, short pins 9-10.
Note: Follow the silkscreen markings on the board, pins 1-2 are at the bottom of this header bank.
- **J27**
To program the iCE40 UltraPlus device U4, short pins 1-2. To program any other device on the board, short pins 9-10.
Note: Follow the silkscreen markings on the board, pins 1-2 are at the top of this header bank.
- **J28**
If you are doing SPI Flash programming, short pins 1-2. Otherwise, leave all pins open.

The iCE40 UltraPlus Mobile Development Board has the following switches:

- **SW5**
This selects the target iCE40 UltraPlus device. Refer to [Table 7.1](#) to select the correct device.

Table 7.1. iCE40 UltraPlus Device Selection

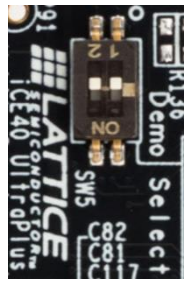
iCE40 UltraPlus FPGA	Key Supported Features	SW5 (2,1)	Reference Image
U1	Display frame buffer: 240x240 display 18-bit color (R6,G6,B6), MIPI DSI interface	OFF, OFF	
U2	On-board stereo microphones (I2S and PDM): 7-microphone expansion connector, headphone amp, audio output jack	OFF, ON	
U3	Sensors: RGB LED, Pressure Sensor, Gyroscope, Accelerometer, Compass	ON, OFF	
U4	640x480 VGA Camera, MIPI CSI interface, expansion connector utilizing single MIPI data lane	ON, ON	

Use the marking on switch to determine SW5-1 and SW5-2 orientations, including the 'ON' direction.

- SW9**
 This switch is used to add/remove the BLE module from the SPI bus. It is recommended that the BLE module be removed from the SPI bus when the module is not in demo use.

Figure 7.1 shows the setting of jumpers and switches while trying to program iCE40 device “U1” directly.

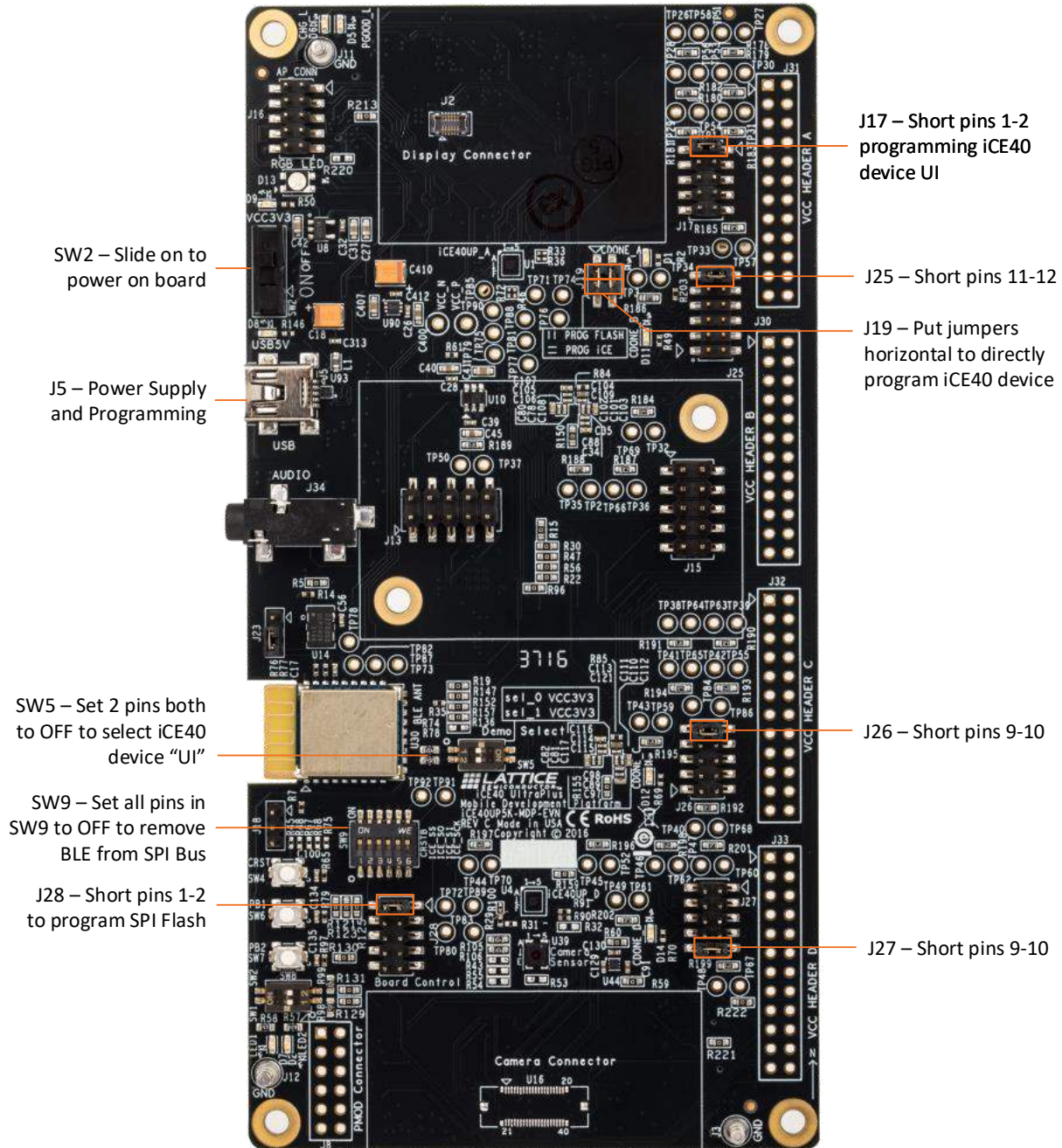

Figure 7.1. Board Configuration for Programming iCE40 UltraPlus Device “UI”

Table 7.2. iCE40 UltraPlus Device Selection Summary

		SPI Flash Demux	CRESET Boot Control Jumper Placement			
Section	iCE40 UltraPlus RefDes	SW5 (2,1)	J17	J25	J26	J27
Camera	U1	OFF,OFF	1-2	11-12	9-10	9-10
Audio	U2	OFF, ON	9-10	1-2	9-10	9-10
Sensor/RGB	U3	ON, OFF	9-10	11-12	1-2	9-10
Display	U4	ON, ON	9-10	11-12	9-10	1-2

7.2. Programming the iCE40 Devices Configuration Memory (CRAM)

To program iCE40 UltraPlus devices' CRAM in Diamond Programmer:

1. Set board jumpers on J19 horizontally for CRAM programming.
2. Remove board jumper J28: 1-2 for CRAM programming.
3. Use Diamond Programmer 3.8 or later.
4. Connect the iCE40 UltraPlus Mobile Development Platform board via the USB cable to a PC or MAC.
5. Start Diamond Programmer.
6. Set **Device Family** to "iCE40 UltraPlus" and **Device** to "iCE40UP5K". Refer [Figure 7.2](#) below.
7. Be sure to perform the "Program, Verify" operation. If you select only the "Program" operation, you may get a false positive that the device has programmed.
8. Field **Programming Speed Settings** should be set to "Use customer Clock Divider" and appropriate value "5" should be set in the text box below.
9. Open the Device Properties dialog. Apply the settings highlighted.
10. **Access mode:** set to "CRAM programming" to allow directly programming iCE40 devices.
11. **Operation:** set to "Fast Program" mode.
12. **Programming File:** load bit stream file for demo.
13. Click **OK** to exit Device Properties dialog.
14. Click the **Program** button in Diamond Programmer to download the bit stream file.

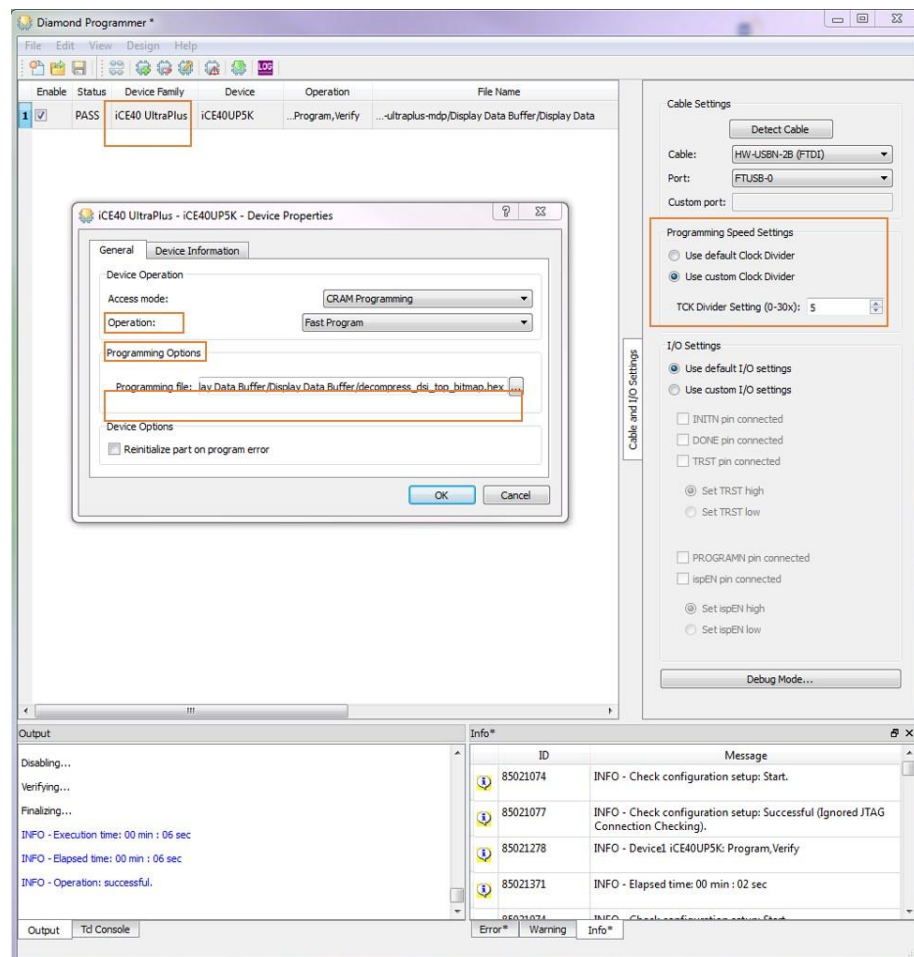

Figure 7.2. Programming iCE40 Devices on Board

7.3. Programming Onboard SPI Flash

To program SPI flash in Diamond Programmer:

1. Set board jumpers on J19 vertically for SPI Flash programming.
2. Install board jumper J28: 1-2 for SPI Flash programming.
3. Start Diamond Programmer.
4. Set Device Family to "ICE40 UltraPlus" and Device to "ICE40UP5K".
5. Be sure to do the "Program, Verify" operation. If you select only the "Program" operation, you may get a false positive that the device has programmed.
6. Field Programming Speed Settings should be set to "Use custom Clock Divider" and appropriate value "5" should be set in the text box below.
7. Open the Device Properties dialog. Apply the settings highlighted.
 - Access mode:** set to "SPI Flash Programming".
 - Operation:** set to "SPI Flash Erase, Program, Verify" mode.
 - Programming File:** load bit stream file for demo.
 - SPI Flash Options:** select correct Flash chip as shown in Figure 7.3 blow.
 - Load from File** button should be used to refresh fields such as "Data file size" and "End address(Hex)".
8. Click **OK** to exit Device Properties dialog.
9. Click the **Program** button in Diamond Programmer to download the bit stream file.

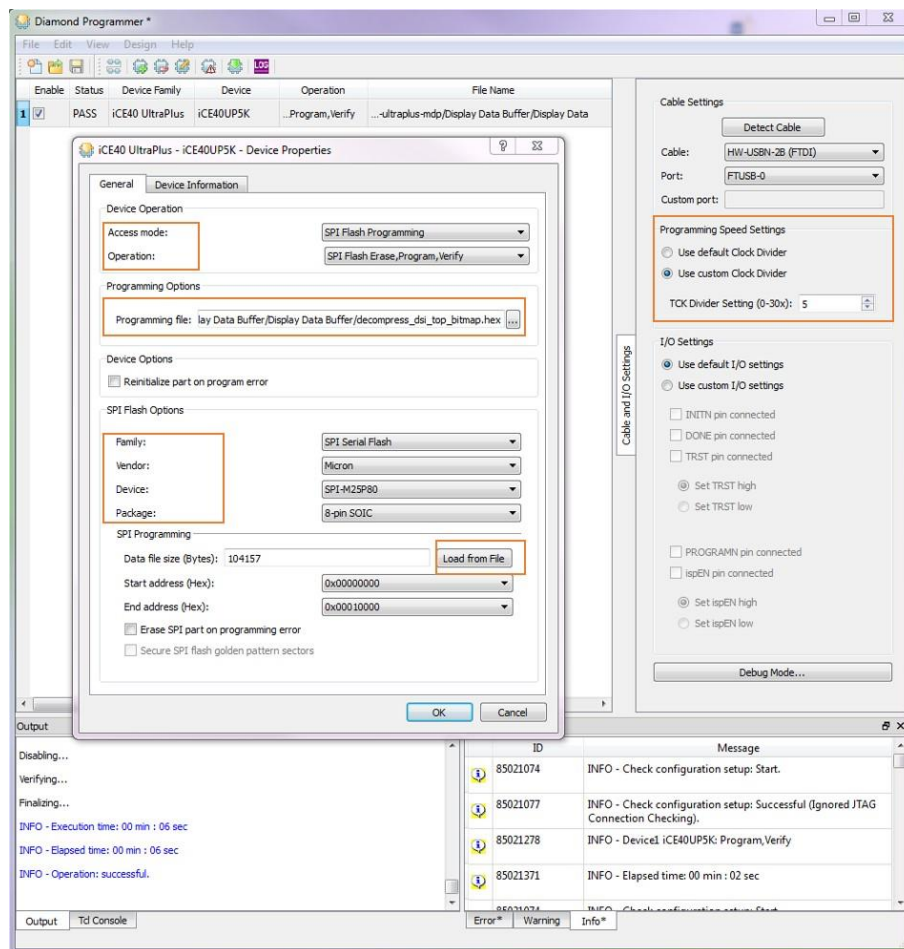

Figure 7.3. Programming SPI Flash on Board

The main differences between programming ICE40 UltraPlus devices and programming SPI Flash are:

1. Board jumpers on J19: Vertical for CRAM programming and horizontal for SPI Flash programming.
2. Board jumpers J28: 1-2: Remove for CRAM programming and install for SPI Flash programming.
3. The settings in the Device Properties dialog box in Diamond Programmer.

For more information on Diamond Programmer, please refer to its user guide.

8. Communication Channels

To enable communication with external tools, devices or Apps on Smart phone, this board features a number of communication channels.

8.1. USB

A USB cable from PC needs to be connected to J5 on board. This communication channel through U9 (FT2232H) is mainly used for programing the SPI flash on board, or program the ICE devices directly depends on settings on jumper J19.

8.2. Bluetooth

This board features a Bluetooth module U30 to enable wireless communication with external devices like smart phones, which is very useful while need to run some APPs on smart phone in demos. This Bluetooth provide UART channel to communicate with ICE40 devices on board.

The operating range of the BLE module is up to 100 meters.

9. Ordering Information

Description	Ordering Part Number	China RoHS Environment- Friendly Use Period (EFUP)
ICE40 UltraPlus Mobile Development Platform	ICE40UP5K-MDP-EVN	

10. PCB Revision History

PCB Revision	Notes
Rev A, Rev B	Prototype revisions, unreleased
Rev C	Production revision Includes two wires added during assembly to connect the UART of the FT2232HL to test points. Specifically, these are U9-38 to J33-1 and U9-39 to J33-3.
Rev D	Production revision Implements the wires from Rev C as PCB traces. Rev C and Rev D schematics are identical.

References

Standards Documents

The standards used in this document and their abbreviations are listed on the table below.

Abbreviation	Standards Publication, Organization, and Date
MIPI	<i>MIPI Alliance, Mobile Industry Processor Interface</i>
CSI2	<i>MIPI Alliance, Camera Serial Interface</i>

For more information on the specifications that are applied in this document, contact the responsible standards groups listed on the table below.

Standards Group	Web URL
MIPI Alliance	http://www.mipi.org

Lattice Semiconductor Documents

Related documents available from your Lattice Semiconductor sales representative are listed on the table below.

Document	Title
Data Sheet DS1056	<i>iCE40 UltraPlus Family Data Sheet</i>

Technical Support Assistance

Submit a technical support case through www.latticesemi.com/techsupport.

Appendix A. iCE40 UltraPlus Mobile Development Board Schematics

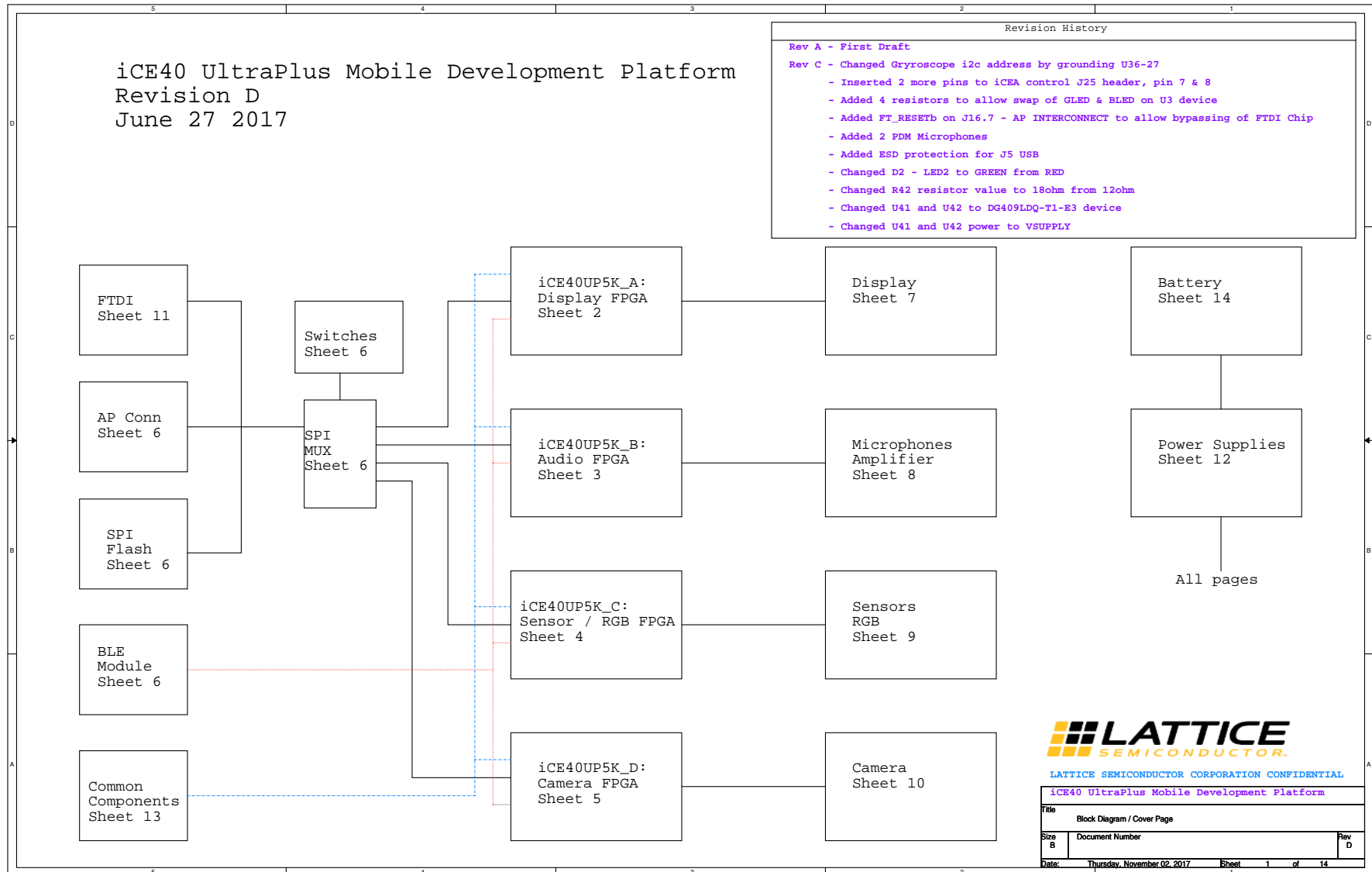

Figure A.1. Block Diagram

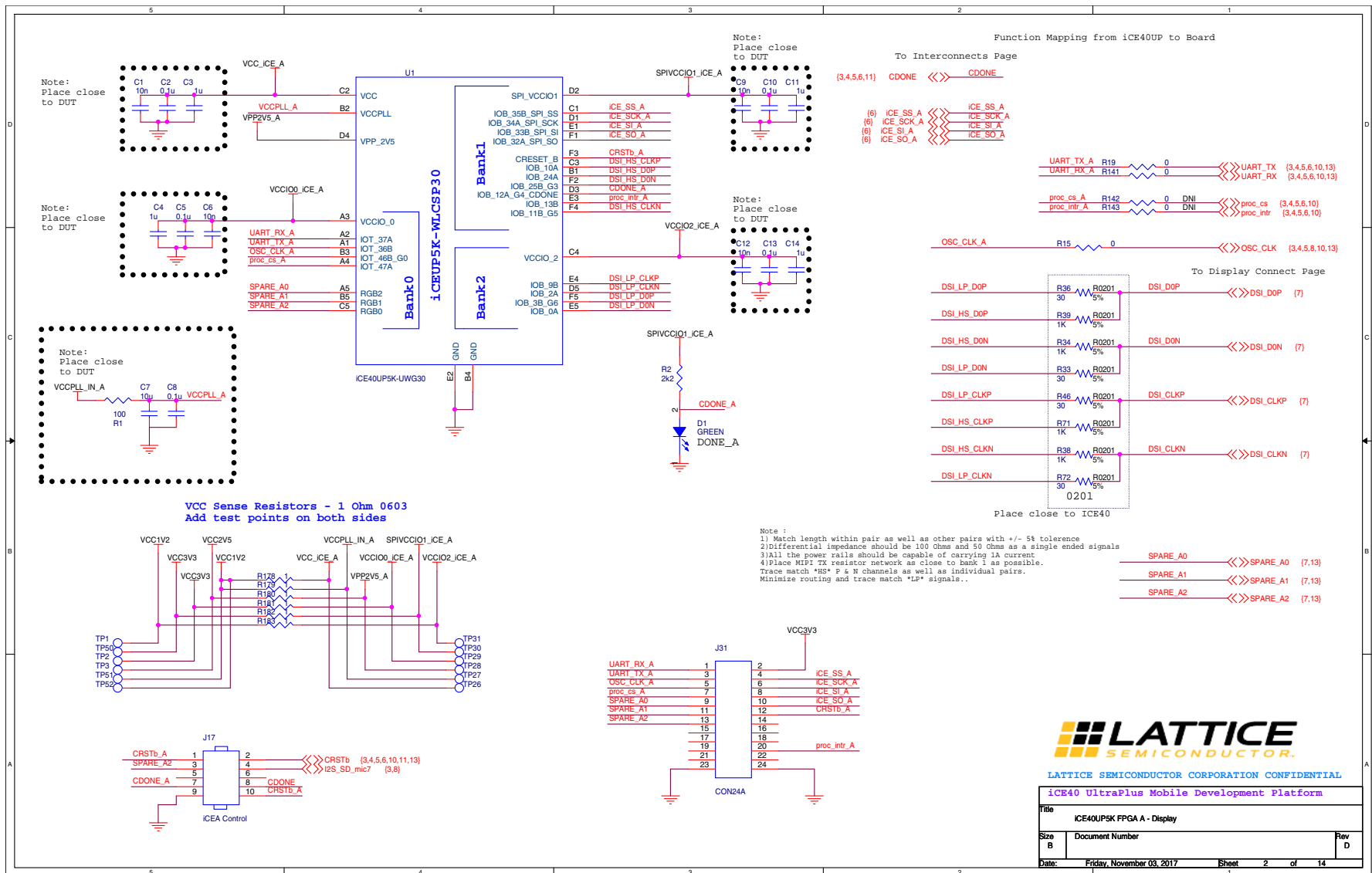

Figure A.2. ICE40UP5K FPGA A - Display

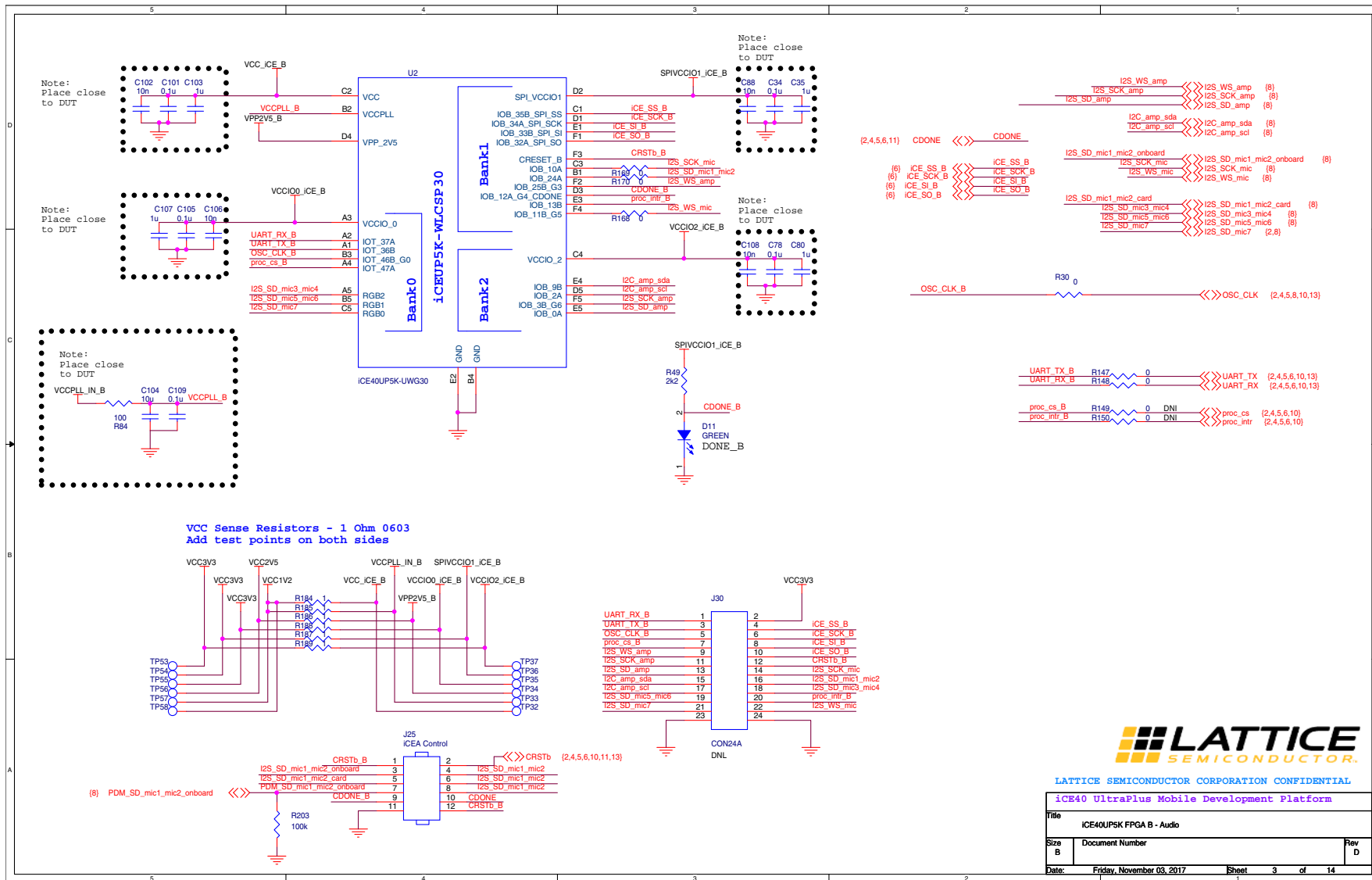

Figure A.3. iCE40UP5K FPGA B - Audio

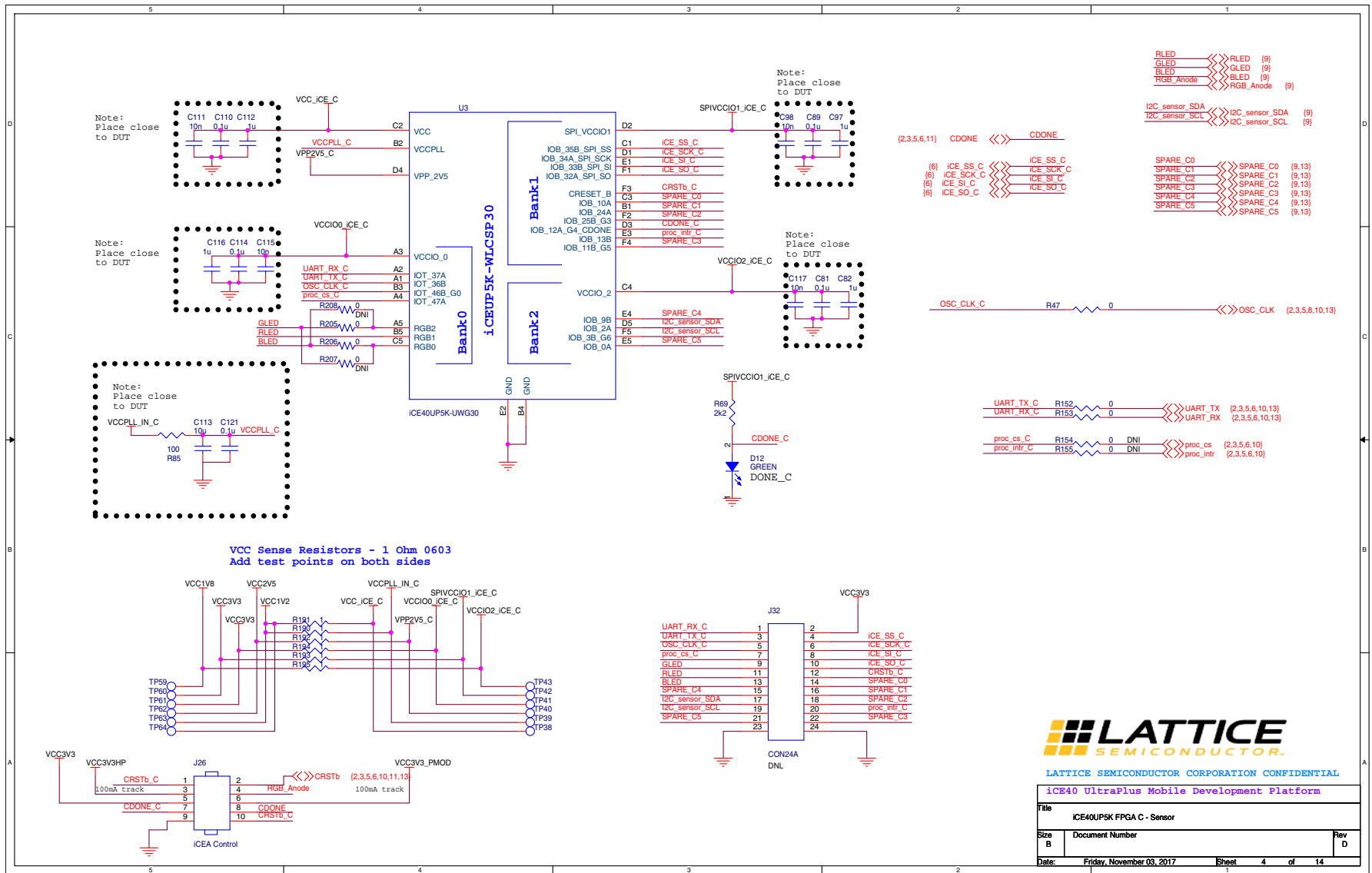

Figure A.4. ICE40UP5K FPGA C - Sensor

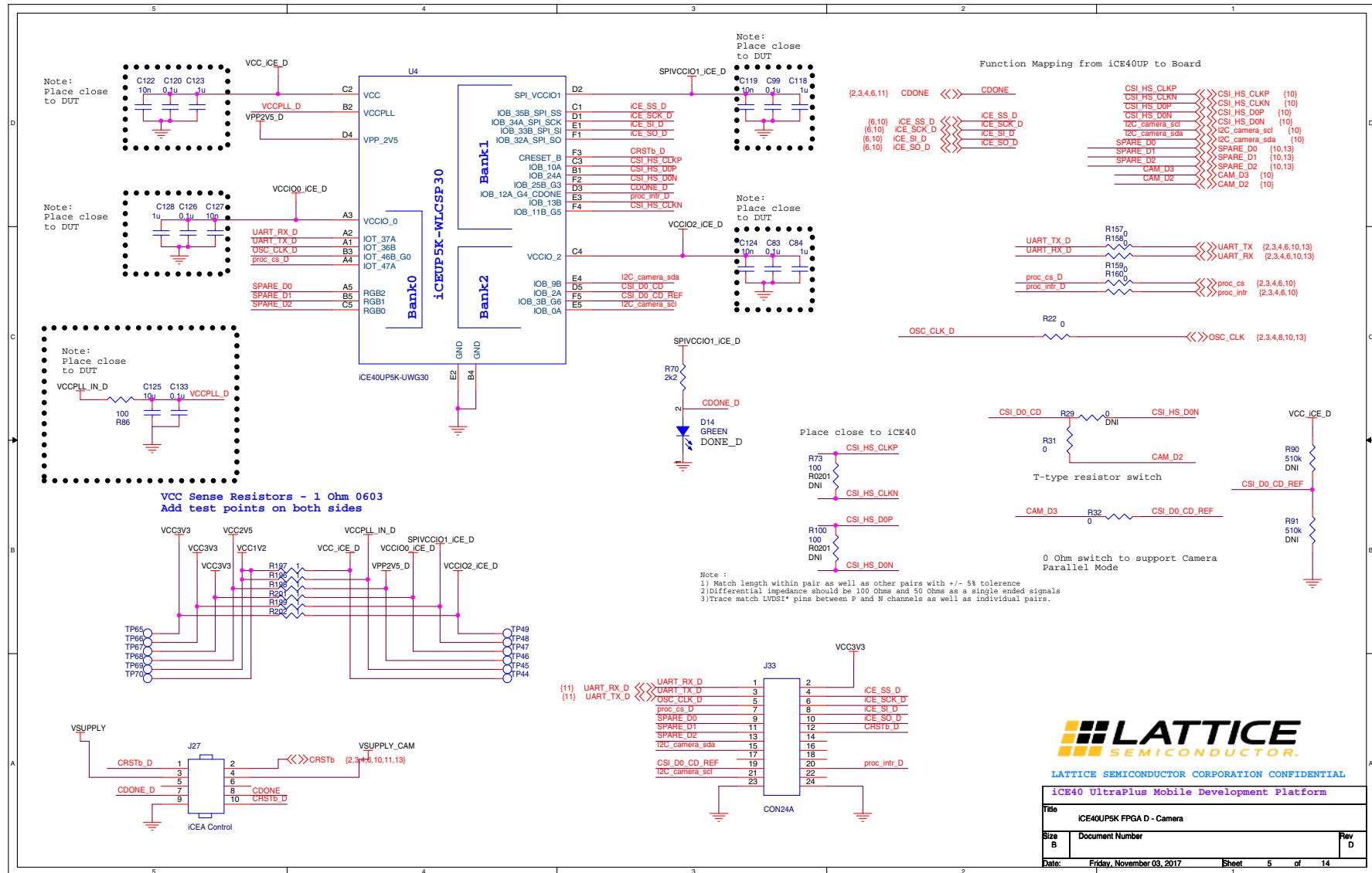

Figure A.5. ICE40UP5K FPGA D - Camera

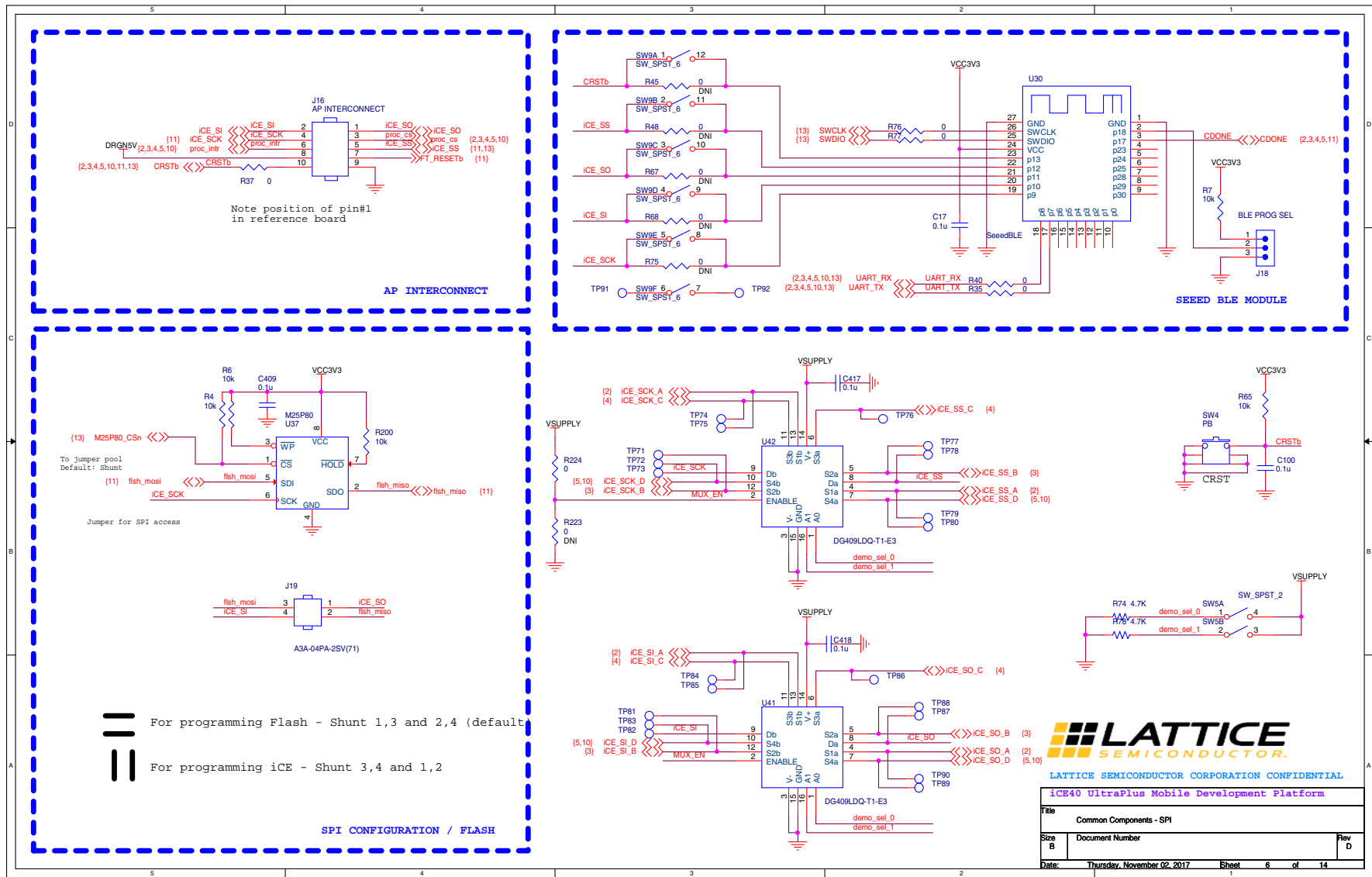

Figure A.6. Common Components- SPI

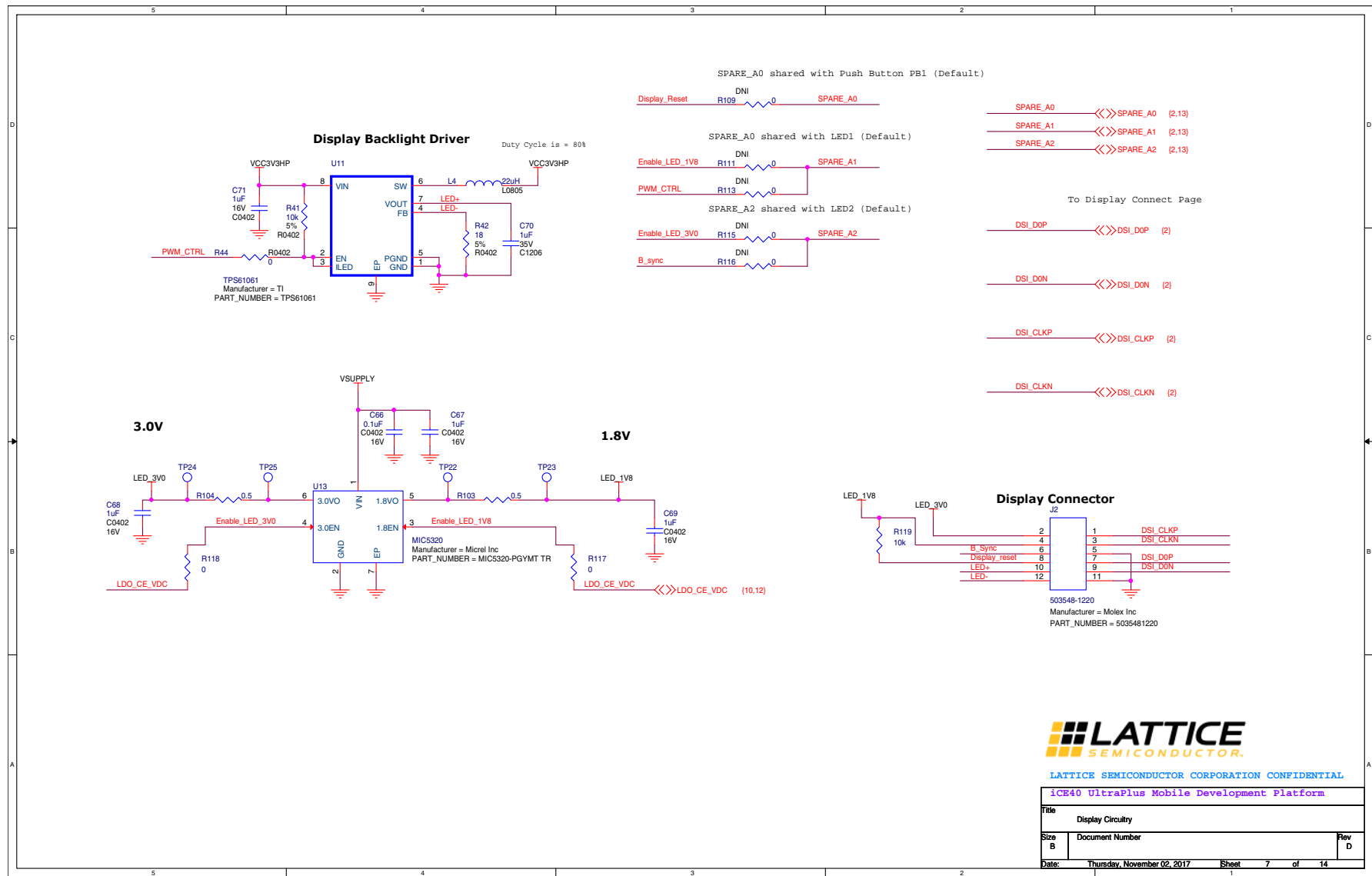

Figure A.7. Display Circuitry

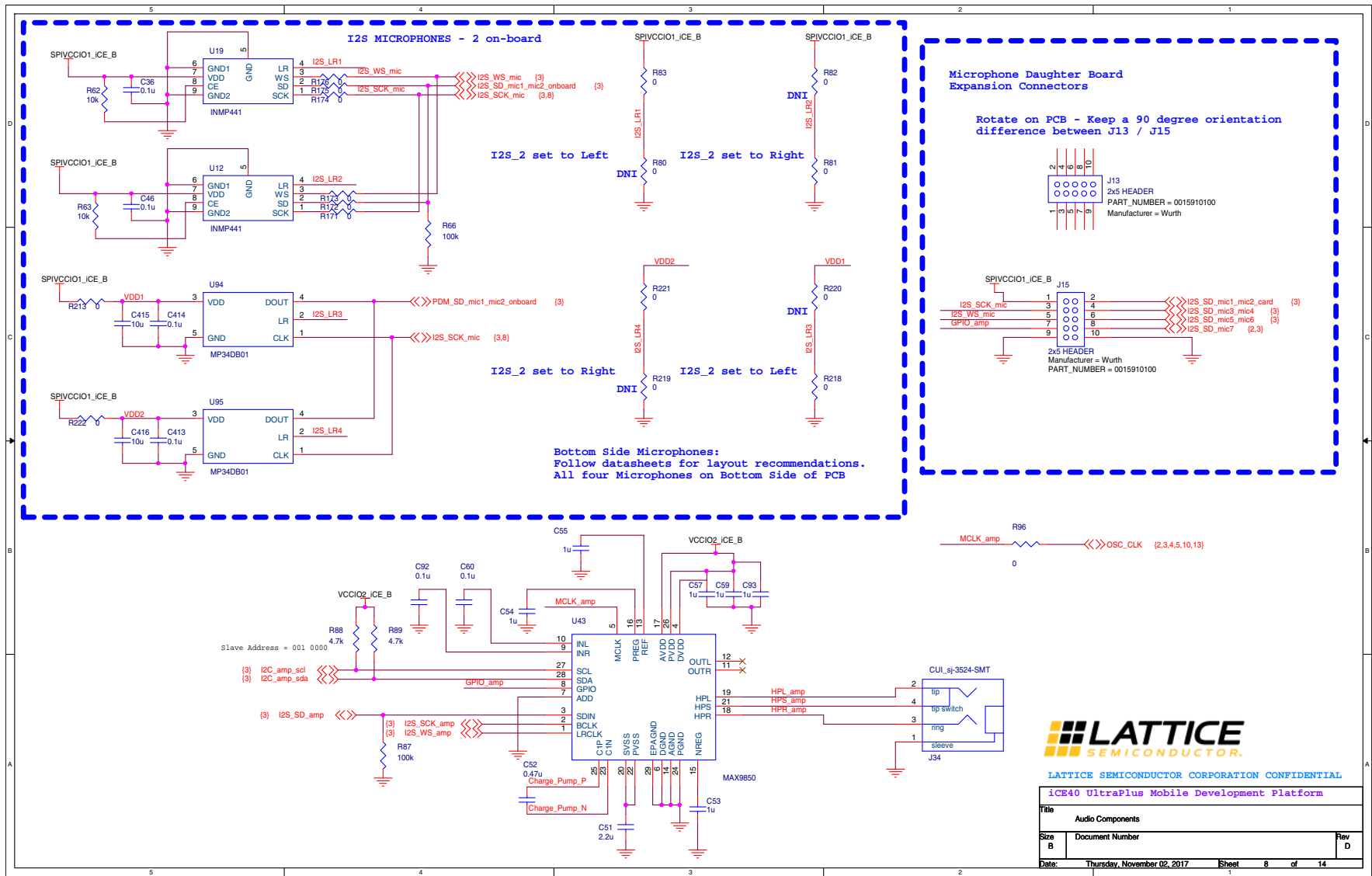

Figure A.8. Audio Circuitry

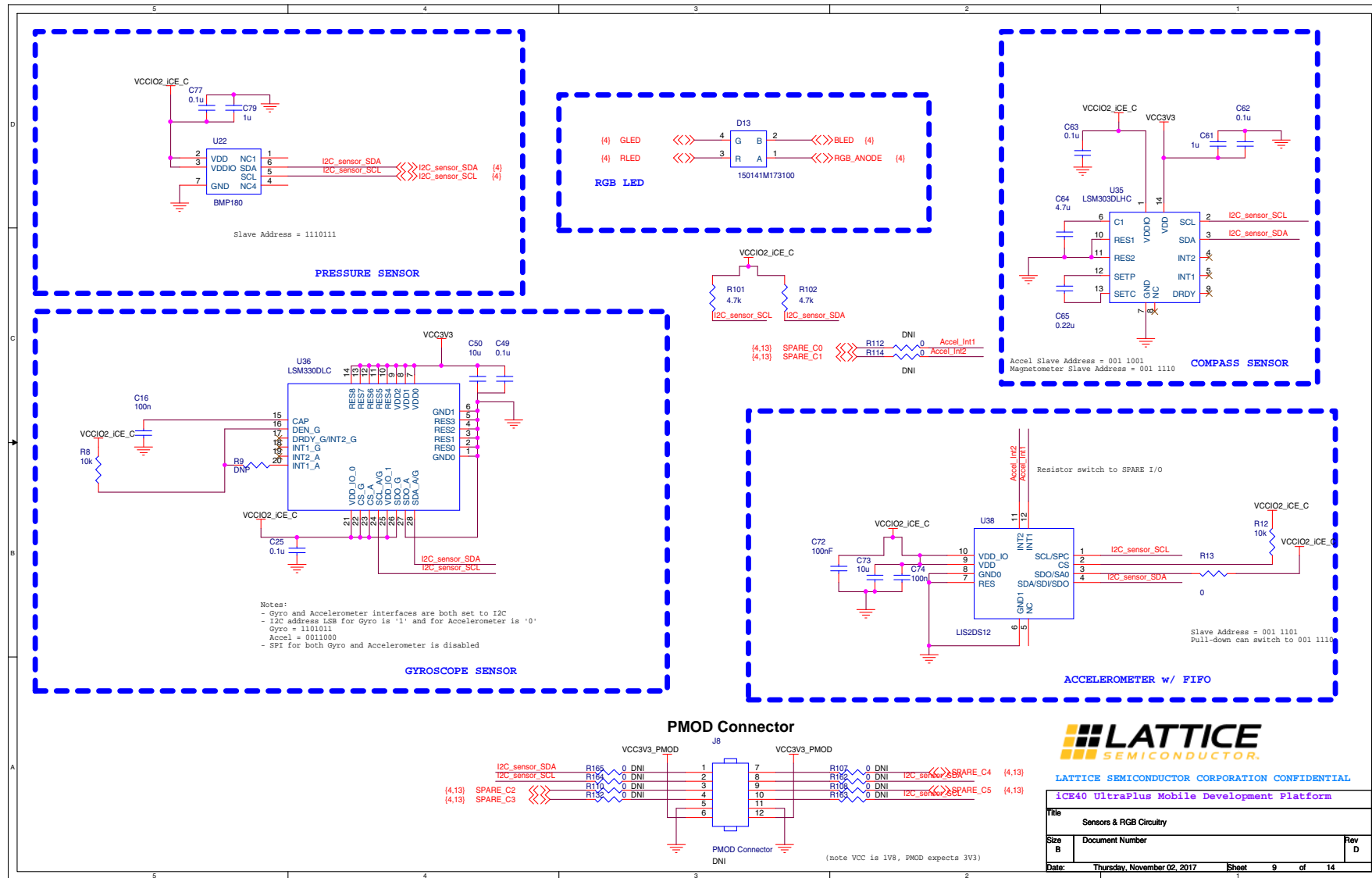

Figure A.9. Sensor & RGB Circuitry

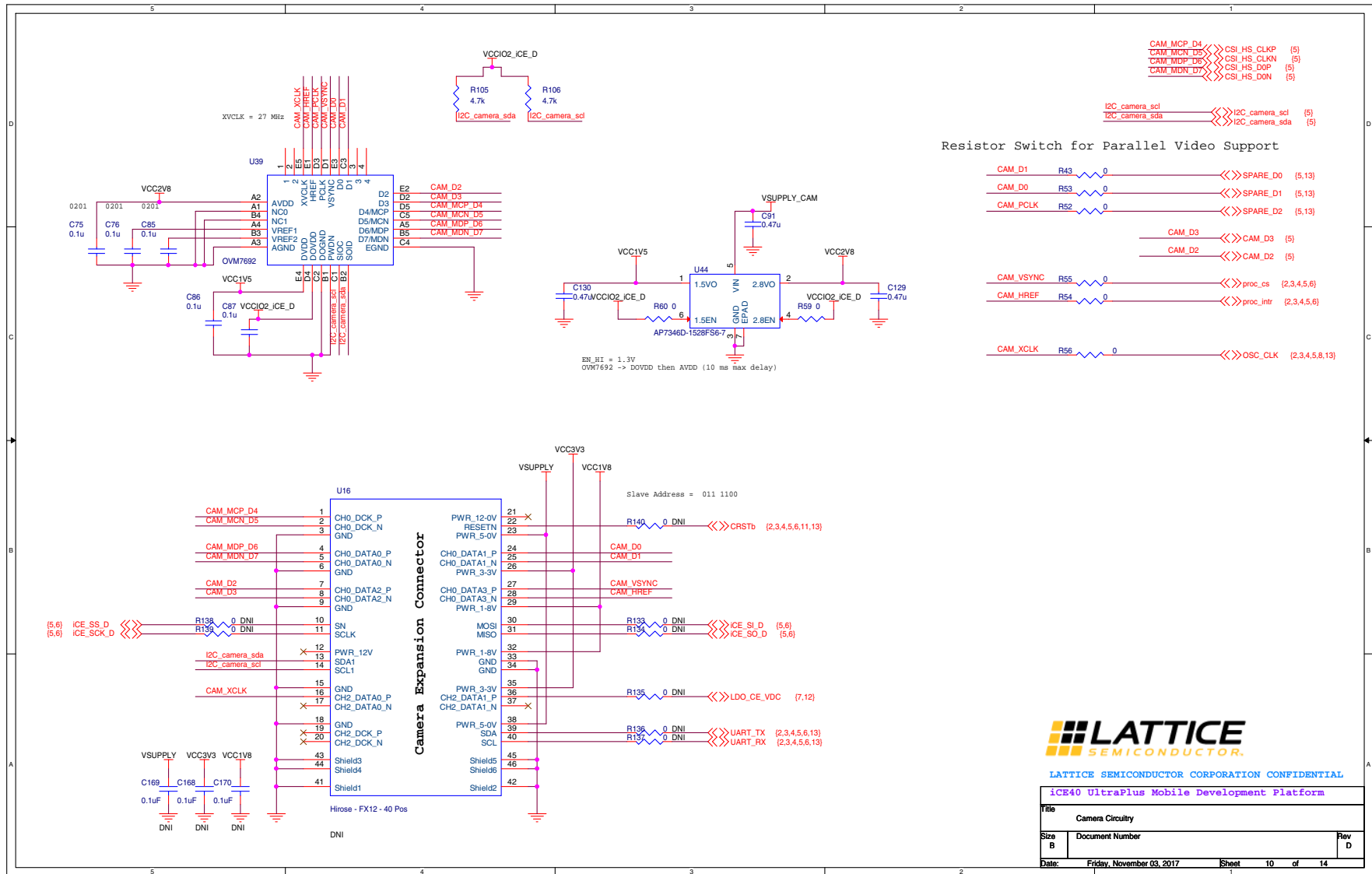

Figure A.10. Camera Circuitry

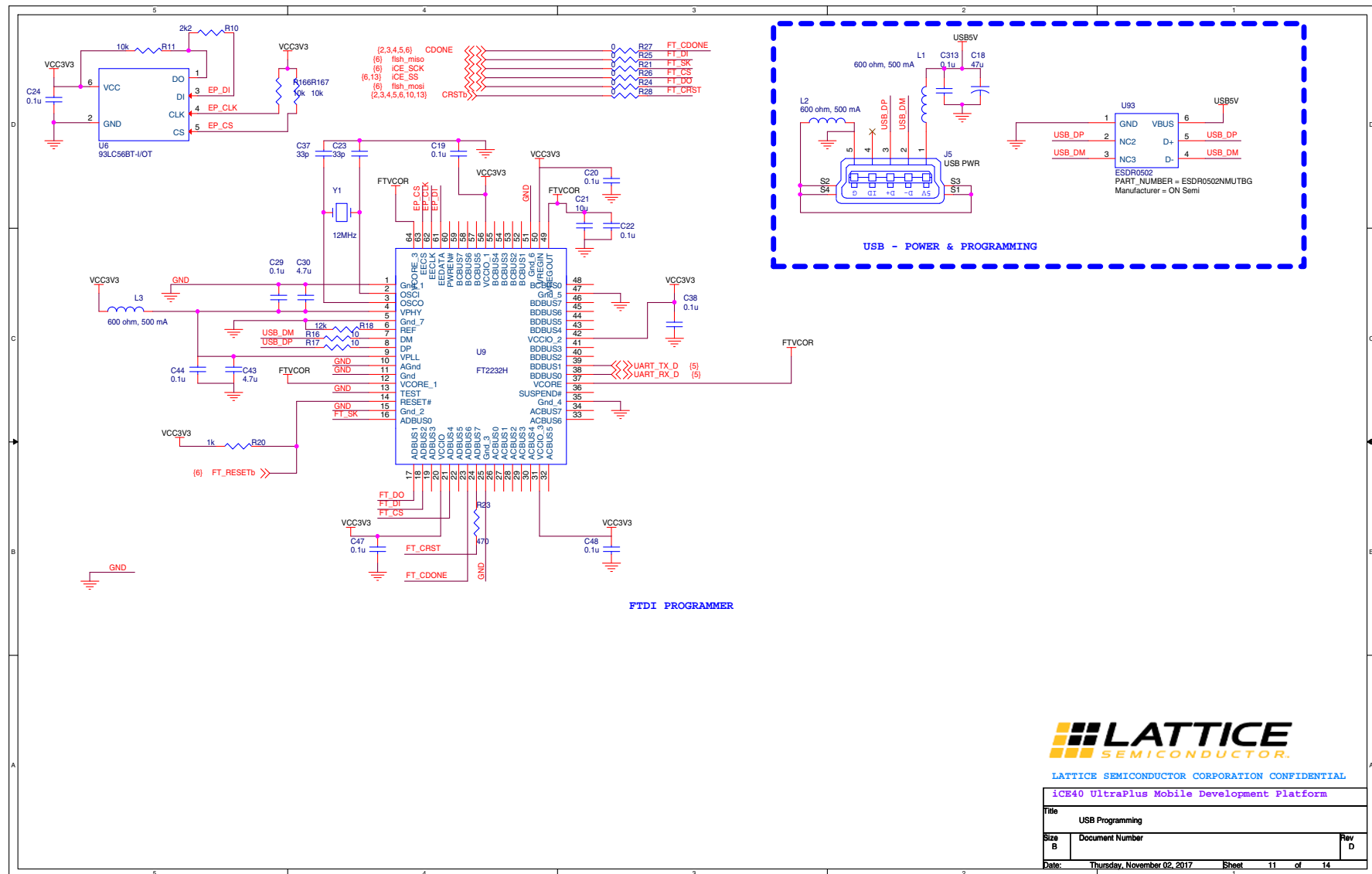

Figure A.11. USB Programming

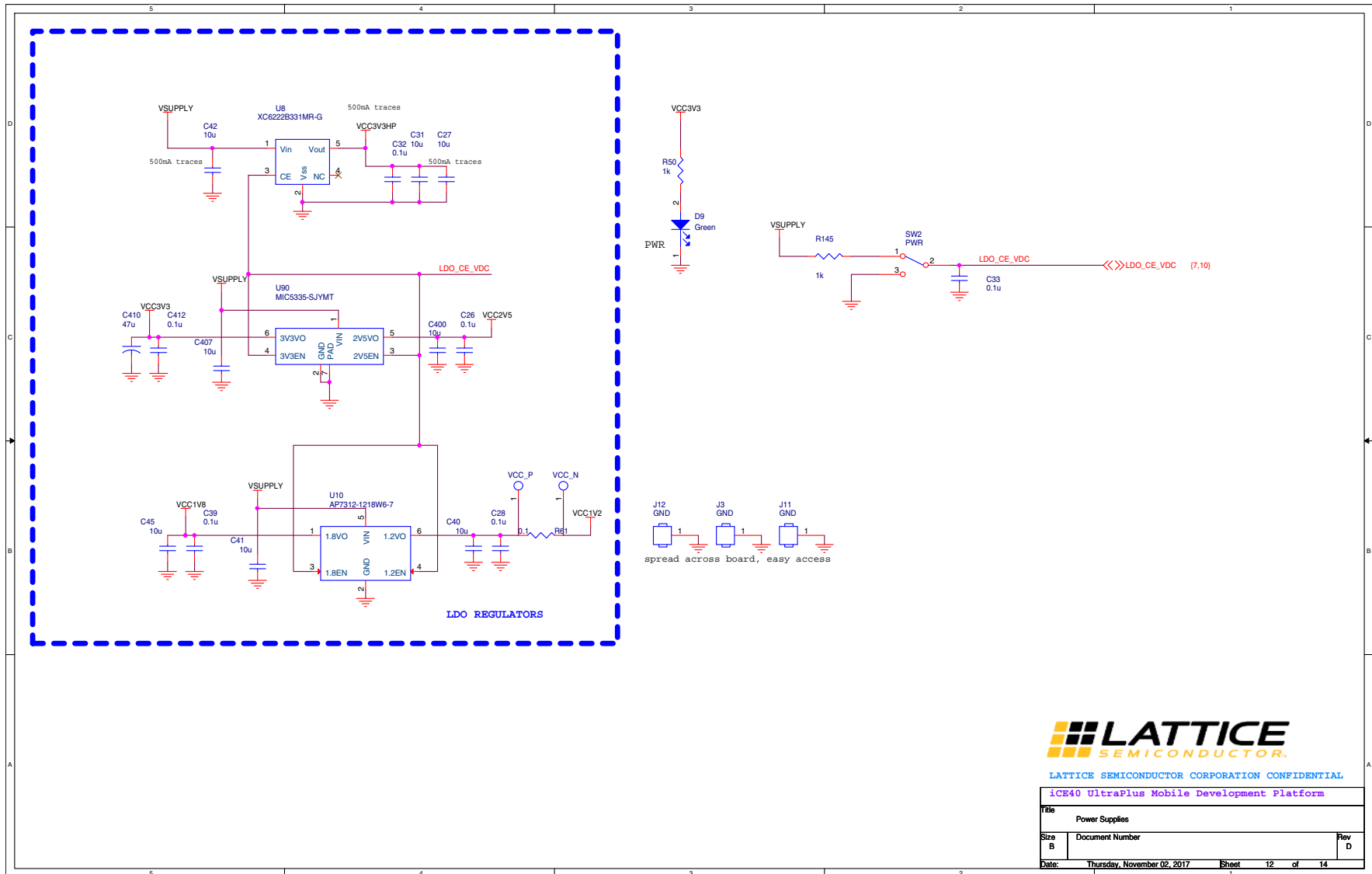

Figure A.12. Power Supplies

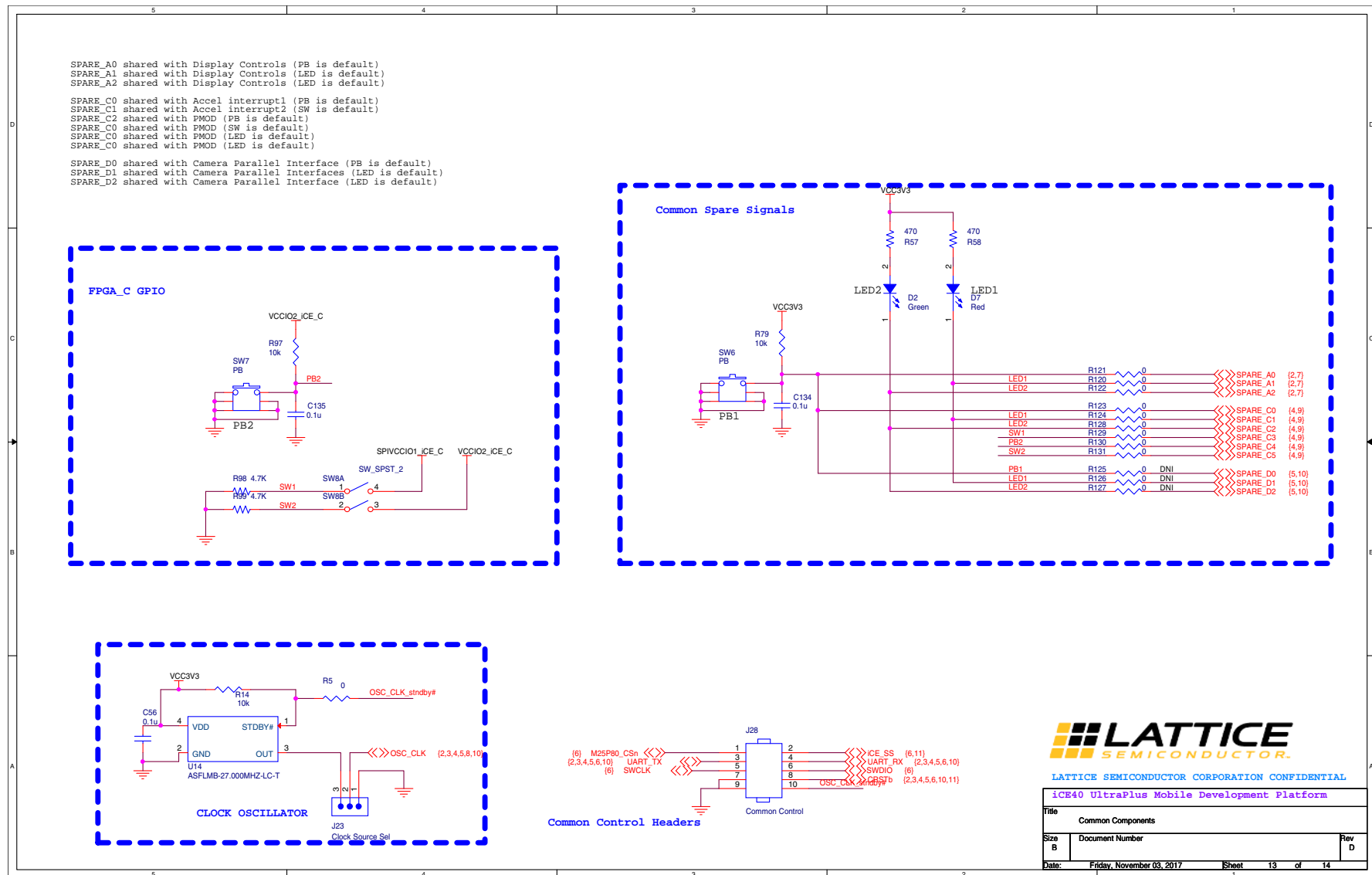

Figure A.13. Common Components

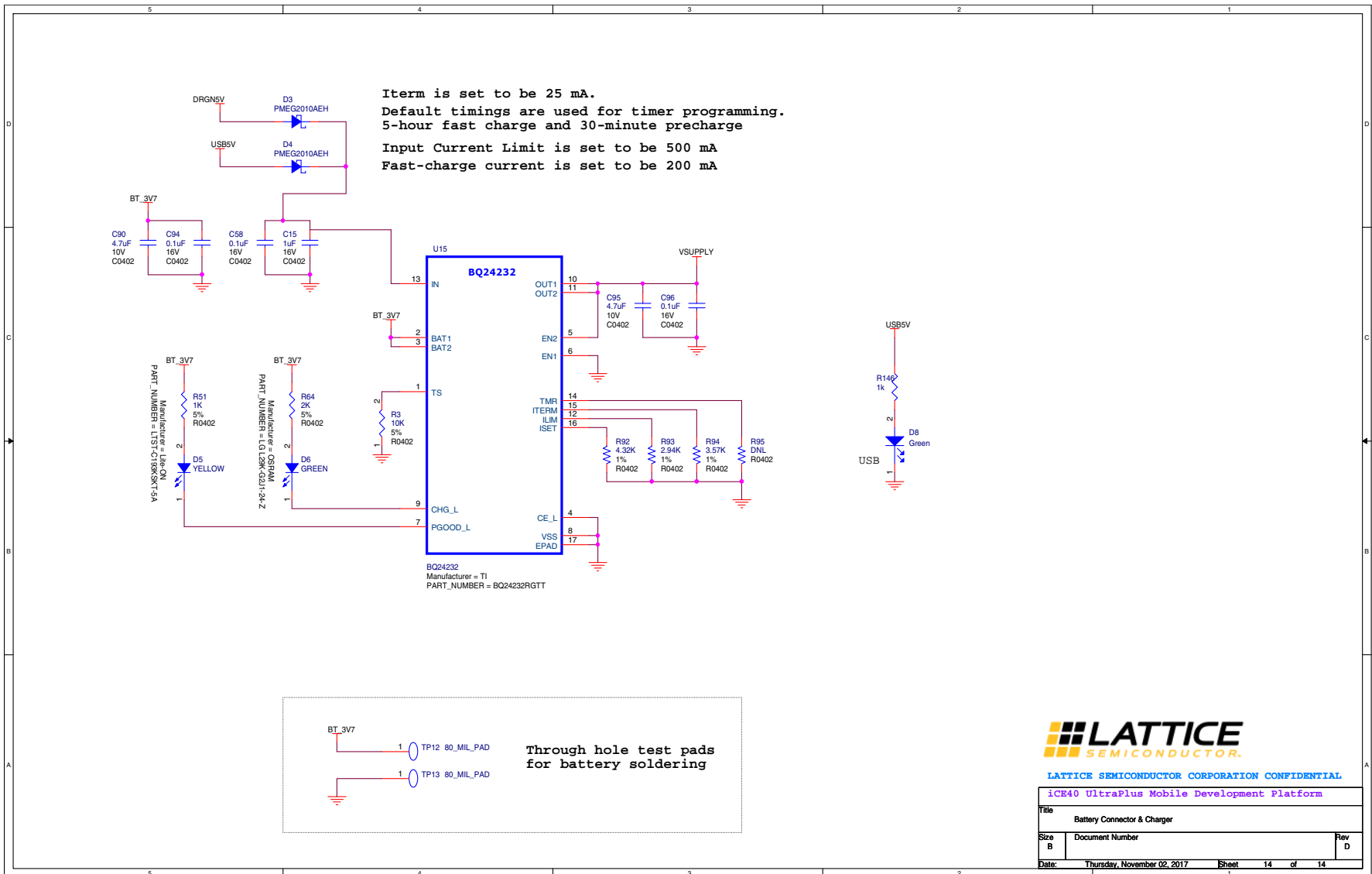

Figure A.14. Battery Connector USB Charger

Appendix B. iCE40 UltraPlus Mobile Development Board Bill of Materials

Item	Reference	Qty	Part	PART_NUMBER	Manufacturer	Description
1	C1, C6, C9, C12, C88, C98, C102, C106, C108, C111, C115, C117, C119, C122, C124, C127	16	10n	GRM033R61C103KA12D	Murata	CAP CER 10000PF 16V 10% X5R 0201
2	C2, C5, C8, C10, C13, C34, C78, C81, C83, C89, C99, C101, C105, C109, C110, C114, C120, C121, C126, C133	20	0.1u	GRM033R61A104KE15D	Murata	CAP CER 0.1UF 10V X5R 0201
3	C3, C4, C11, C14, C35, C53, C54, C55, C57, C59, C61, C79, C80, C82, C84, C93, C97, C103, C107, C112, C116, C118, C123, C128	24	1u	885012105012	Wurth	CAP CER 1UF 10V X5R 0402
4	C7, C73, C104, C113, C125	5	10u	CL05A106MP5NUNC	Samsung	CAP CER 10UF 10V X5R 0402
5	C15	1	1uF	C1005X5R1C105K050BC	TDK	CAP CER 1UF 16V 10% X5R 0402
6	C16	1	100n	885012205037	Wurth	CAP CER 0.1UF 16V X7R 0402
7	C17, C19, C20, C22, C24, C25, C26, C28, C29, C32, C33, C36, C38, C39, C44, C47, C48, C49, C56, C60, C62, C63, C75, C76, C77, C85, C86, C87, C92, C100, C134, C135, C313, C409, C412, C414, C417, C418	38	0.1u	885012105010	Wurth	CAP CER 0.1UF 10V X5R 0402
8	C18, C410	2	47u	TCJB476M010R0070	AVX	CAP TANT POLY 47UF 10V 1210
9	C21, C27, C31, C40, C45, C400	6	10u	CL10A106MQ8NNNC	Samsung	CAP CER 10UF 6.3V X5R 0603
10	C23, C37	2	33p	885012005058	Wurth	CAP CER 33PF 50V NP0 0402
11	C30, C43, C64	3	4.7u	CC0603KRX5R6BB475	Yageo	CAP CER 4.7UF 10V X5R 0603
12	C41, C42, C407	3	10u	CL10X106MP8NRNC	Samsung	CAP CER 10UF 10V X6S 0603
13	C46, C413	2	0.1u	885012105010	Wurth	CAP CER 0.1UF 10V X5R 0402
14	C50	1	10u	CL10X106MP8NRNC	Samsung	CAP CER 10UF 10V X6S 0603

Item	Reference	Qty	Part	PART_NUMBER	Manufacturer	Description
15	C51	1	2.2u	C1005X5R1C225K050BC	TDK	CAP CER 2.2UF 16V 10% X5R 0402
16	C52, C91, C129, C130	4	0.47u	C1005X5R1E474K050BB	TK	CAP CER 0.47UF 25V X5R 0402
17	C58, C94, C96	3	0.1uF	885012105016	Würth	CAP CER 0.1UF 16V X5R 0402
18	C65	1	0.22u	885012206048	Würth	CAP CER 0.22UF 16V X7R 0603
19	C66	1	0.1uF	885012105016	Würth	CAP CER 0.1UF 16V X5R 0402
20	C67, C68, C69	3	1uF	GRM155R61C105KE01D	Murata	CAP CER 1UF 16V 10% X5R 0402
21	C70	1	1uF	885012208093	Würth	CAP CER 1UF 50V X7R 1206
22	C71	1	1uF	GRM155R61C105KE01D	Murata	CAP CER 1UF 16V 10% X5R 0402
23	C72	1	100nF	885012105016	Würth	CAP CER 0.1UF 16V X5R 0402
24	C74	1	100n	885012105016	Würth	CAP CER 0.1UF 16V X5R 0402
25	C90, C95	2	4.7uF	C1005X5R1A475K050BC	TDK	CAP CER 4.7UF 10V 10% X5R 0402
26	C168, C169, C170	3	0.1uF	885012105016	Würth	CAP CER 0.1UF 16V X5R 0402
27	C415, C416	2	10u	CL10X106MP8NRNC	Samsung	CAP CER 10UF 10V X6S 0603
28	D1, D11, D12, D14	4	GREEN	150060GS75000	Würth	LED GREEN CLEAR 0603 SMD
29	D2	1	Green	150060GS75000	Würth	LED GREEN CLEAR 0603 SMD
30	D3, D4	2	PMEG2010AEH	PMEG2010AEH, 115	NXP Semiconductor	DIODE SCHOTTKY 20V 1A SOD123F
31	D5	1	YELLOW	150060YS75000	Würth	LED YELLOW RECT CLEAR 0603
32	D6	1	GREEN	150060GS75000	Würth	LED SMARTLED GREEN 570NM 0603
33	D7	1	Red	150060SS75000	Würth	LED RED CLEAR 0603 SMD
34	D8, D9	2	Green	150060VS75000	Würth	LED SUPER GREEN CLEAR 0603 SMD
35	D13	1	150141M173100	150141M173100	Würth	LED RGB CLEAR 1411 SMD
36	J2	1	503548-1220	5035481220	Molex Inc	CONN RCPT BTB 12POS DL VERT SMD
37	J3, J11, J12	3	GND	608001162100	Würth	
38	J5	1	USB PWR	65100516121	Würth	CONN COM TYPE B MINI USB SMD 5P
39	J8	1	PMOD Connector	-	-	CONN HEADER .100 DUAL STR 10POS
40	J13, J15	2	2x5 HEADER	61001021121	Würth	CONN HEADER VERT DUAL 10POS 2.54
41	J16	1	AP INTERCONNECT	62101021921	Würth	2.00 mm SMT Dual Pin Header
42	J17, J26, J27	3	iCEA Control	62101021921	Würth	2.00 mm SMT Dual Pin Header
43	J18	1	BLE PROG SEL	62000311121	Würth	2.00 mm THT Pin Header

Item	Reference	Qty	Part	PART_NUMBER	Manufacturer	Description
44	J19	1	A3A-04PA-2SV(71)	A3A-4PA-2SV(71)	Hirose	CONN HEADER 2mm DUAL STR 4POS SMT
45	J23	1	Clock Source Sel	62000311121	Würth	2.00 mm THT Pin Header
46	J25	1	iCEA Control	57202-G52-06LF	Amphenol FCI	12 Positions Header, Unshrouded Connector 0.079" (2.00mm) Surface Mount Gold, GXT™
47	J28	1	Common Control	62101021921	Würth	2.00 mm SMT Dual Pin Header
48	J30, J32	2	CON24A	—	—	—
49	J31, J33	2	CON24A	—	—	—
50	J34	1	CUI_sj-3524-SMT	SJ-3524-SMT-TR	CUI Inc.	CONN AUDIO JACK 3.5MM STEREO SMD
51	L1, L2, L3	3	600 Ohm, 500 mA	MMZ1608R601A	TDK	FERRITE BEAD 600 OHM 0603 1LN
52	L4	1	22uH	AIML-0805HC-220M-T	Abrakon Corporation	HIGH CURRENT CHIP IND 22.0UH 20%
53	R1, R84, R85, R86	4	100	RC1005J101CS	Samsung	RES 100 OHM 1/16W 5% 0402
54	R2, R49, R69, R70	4	2k2	RC1005J222CS	Samsung	RES 2.2K OHM 1/16W 5% 0402
55	R3	1	10K	ERJ-2RKF1002X	Panasonic	RES 10K OHM 1/10W 1% 0402 SMD
56	R4, R6, R7, R8, R12, R62, R63, R65, R200	9	10k	ERJ-2RKF1002X	Panasonic	RES 10K OHM 1/10W 1% 0402 SMD
57	R5	1	0	ERJ-3GEY0R00V	Panasonic	RES SMD 0.0 OHM JUMPER 1/10W 0603
58	R9	1	DNP	—	—	—
59	R10	1	2k2	RC1005J222CS	Samsung	RES 2.2K OHM 1/16W 5% 0402
60	R11, R14, R79, R97, R166, R167	6	10k	ERJ-2RKF1002X	Panasonic	RES 10K OHM 1/10W 1% 0402 SMD
61	R13, R29, R35, R37, R40, R76, R77, R205, R206, R224	10	0	ERJ-2GE0R00X	Panasonic	RES 0.0 OHM 1/10W 0402 SMD
62	R15, R19, R22, R30, R47, R56, R59, R60, R81, R83, R96, R141, R142, R143, R147, R148, R149, R150, R152, R153, R154, R155, R157, R158, R159, R160, R168, R169, R170, R171, R172, R173, R174, R175, R176, R213, R218, R221, R222	39	0	ERJ-3GEY0R00V	Panasonic	RES SMD 0.0 OHM JUMPER 1/10W 0603

Item	Reference	Qty	Part	PART_NUMBER	Manufacturer	Description
63	R16, R17	2	10	RC1005J100CS	Samsung	RES 10 OHM 1/16W 5% 0402
64	R18	1	12k	RC1005F123CS	Samsung	RES 12K OHM 1/16W 1% 0402
65	R20, R50, R145, R146	4	1k	RC1005J102CS	Samsung	RES 1K OHM 1/16W 5% 0402
66	R21, R24, R25, R26, R27, R28	6	0	RC1005J000CS	Samsung	RES 0.0 OHM 1/16W JUMP 0402
67	R23	1	470	RC1005J471CS	Samsung	RES 470 OHM 1/16W 5% 0402
68	R31	1	0	ERJ-2GE0R00X	Panasonic	RES 0.0 OHM 1/10W 0402 SMD
69	R32, R43, R52, R53, R54, R55, R107, R108, R110, R132, R133, R134, R135, R136, R137, R138, R139, R140, R162, R163, R164, R165	22	0	ERJ-3GEY0R00V	Panasonic	RES SMD 0.0 OHM JUMPER 1/10W 0603
70	R33, R36, R72	3	30	ERJ-1GEJ300C	Panasonic	RES 30 OHM 1/20W 5% 0201 SMD
71	R34, R38, R39, R71	4	1K	ERJ-1GEF1001C	Panasonic	RES SMD 1K OHM 1% 1/20W 0201
72	R41	1	10k	ERJ-2GEJ103X	Panasonic	RES SMD 10K OHM 5% 1/10W 0402
73	R42	1	18	ERJ-2GEJ180X	Panasonic	RES SMD 18 OHM 5% 1/10W 0402
74	R44	1	0	ERJ-2GE0R00X	Panasonic	RES SMD 0.0 OHM JUMPER 1/10W 0402
75	R45, R48, R67, R68, R75, R223	6	0	ERJ-2GE0R00X	Panasonic	RES 0.0 OHM 1/10W 0402 SMD
76	R46	1	30	ERJ-1GEJ300C	Panasonic	RES 30 OHM 1/20W 5% 0201 SMD
77	R51	1	1K	ERJ-2GEJ102X	Panasonic	RES SMD 1K OHM 5% 1/10W 0402
78	R57, R58	2	470	ERJ-3GEYJ471V	Panasonic	RES SMD 470 OHM 5% 1/10W 0603
79	R61	1	0.1	RUT1005FR100CS	Samsung	RES SMD 0.1 OHM 1% 1/10W 0402
80	R64	1	2K	ERJ-2GEJ202X	Panasonic	RES SMD 2K OHM 5% 1/10W 0402
81	R66, R87, R203	3	100k	RC1005J104CS	Samsung	RES SMD 100K OHM 5% 1/16W 0402
82	R73, R100	2	100	ERJ-1GEF1000C	Panasonic	RES SMD 100 OHM 1% 1/20W 0201
83	R74, R78, R98, R99	4	4.7K	ERJ-3EKF4701V	Panasonic	RES SMD 4.7K OHM 1% 1/10W 0603
84	R80, R82	2	0	ERJ-3GEY0R00V	Panasonic	RES SMD 0.0 OHM JUMPER 1/10W 0603
85	R88, R89, R101, R102	4	4.7k	ERJ-2RKF4701X	Panasonic	RES SMD 4.7K OHM 1% 1/10W 0402
86	R90, R91	2	510k	ERJ-2RKF5103X	Panasonic	RES SMD 510K OHM 1% 1/10W 0402

Item	Reference	Qty	Part	PART_NUMBER	Manufacturer	Description
87	R92	1	4.32K	ERJ-2RKF4321X	Panasonic	RES SMD 4.32K OHM 1% 1/10W 0402
88	R93	1	2.94K	ERJ-2RKF2941X	Panasonic	RES SMD 2.94K OHM 1% 1/10W 0402
89	R94	1	3.57K	ERJ-2RKF3571X	Panasonic	RES SMD 3.57K OHM 1% 1/10W 0402
90	R95	1	DNL	—	—	—
91	R103, R104	2	0.5	RL0603FR-070R5L	Yageo	RES SMD 0.5 OHM 1% 1/10W 0603
92	R105, R106	2	4.7k	ERJ-3EKF4701V	Panasonic	RES SMD 4.7K OHM 1% 1/10W 0603
93	R109, R111, R113, R115, R116	5	0	ERJ-3GEY0R00V	Panasonic	RES SMD 0.0 OHM JUMPER 1/10W 0603
94	R112, R114	2	0	ERJ-3GEY0R00V	Panasonic	RES SMD 0.0 OHM JUMPER 1/10W 0603
95	R117, R118, R120, R121, R122, R123, R124, R125, R126, R127, R128, R129, R130, R131	14	0	ERJ-3GEY0R00V	Panasonic	RES SMD 0.0 OHM JUMPER 1/10W 0603
96	R119	1	10k	ERJ-3EKF1002V	Panasonic	RES SMD 10K OHM 1% 1/10W 0603
97	R178, R179, R180, R181, R182, R183, R184, R185, R186, R187, R188, R189, R190, R191, R192, R193, R194, R195, R196, R197, R198, R199, R201, R202	24	1	ERJ-3GEYJ1R0V	Panasonic	RES SMD 1 OHM 5% 1/10W 0603
98	R207, R208	2	0	ERJ-2GE0R00X	Panasonic	RES SMD 0.0 OHM JUMPER 1/10W 0402
99	R219, R220	2	0	ERJ-3GEY0R00V	Panasonic	RES SMD 0.0 OHM JUMPER 1/10W 0603
100	SW2	1	PWR	EG1218	E-Switch	SWITCH SLIDE SPDT 30V.2A PC MNT
101	SW4, SW6, SW7	3	PB	TL1015AF160QG	E-Switch	SWITCH TACTILE SPST-NO 0.05A 12V
102	SW5, SW8	2	SW_SPST_2	416131160802	Würth	DIP SWITCH 1.27MM PITCH 2POL 24V
103	SW9	1	SW_SPST_6	416131160806	Würth	DIP SWITCH 1.27MM PITCH 6POL 24V
104	TP1, TP2, TP3, TP26, TP27, TP28, TP29, TP30, TP31, TP32, TP33, TP34, TP35, TP36, TP37, TP38, TP39, TP40, TP41, TP42, TP43, TP44, TP45, TP46, TP47, TP48, TP49, TP50, TP51, TP52, TP53, TP54, TP55, TP56, TP57, TP58,	70	T POINT R	—	—	—

Item	Reference	Qty	Part	PART_NUMBER	Manufacturer	Description
	TP59, TP60, TP61, TP62, TP63, TP64, TP65, TP66, TP67, TP68, TP69, TP70, TP71, TP72, TP73, TP74, TP75, TP76, TP77, TP78, TP79, TP80, TP81, TP82, TP83, TP84, TP85, TP86, TP87, TP88, TP89, TP90, TP91, TP92					
105	TP12, TP13	2	80_MIL_PAD	—	—	TEST POINT PC MINIATURE SMT
106	TP22, TP23, TP24, TP25	4	T POINT R	—	—	—
107	U1, U2, U3, U4	4	iCE40UP5K WLCSP 30	iCE40UP5K-UWG30	Lattice	—
108	U6	1	93LC56BT-I/OT	93LC56BT-I/OT	Microchip Technology	IC EEPROM 2KBIT 2MHZ SOT23-6
109	U8	1	XC6222B331MR-G	XC6222B331MR-G	Torex Semiconductor Ltd	IC REG LDO 3.3V 0.7A SOT25
110	U9	1	FT2232H	FT2232HL	FTDI	IC USB HS DUAL UART/FIFO 64-LQFP
111	U10	1	AP7312-1218W6-7	AP7312-1218W6-7	Diodes Inc	IC REG LDO 1.2V/1.8V 0.15A SOT26
112	U11	1	TPS61061	TPS61061DRBR	TI	IC LED DRIVER WHITE BCKLGT 8SON
113	U12, U19	2	INMP441	INMP441ACEZ	Invensense	Omnidirectional Microphone with bottom port and I2S digital port
114	U13	1	MIC5320	MIC5320-PGYMT TR	Micrel Inc	IC REG LDO 3V/1.8V 0.15A 6TMLF
115	U14	1	ASFLMB-27.000MHZ-LC-T	ASFLMB-27.000MHZ-LC-T	ABRACON	OSC MEMS 27.000MHZ CMOS SMD
116	U15	1	BQ24232	BQ24232RGTT	TI	IC LI+ CHARGER PWR MGMT 16QFN
117	U16	1	Hirose - FX12 - 40 Pos	FX12B-40P-0.45V	Hirose	CONN PLUG 40POS 0.4MM SMD SHIELD
118	U22	1	BMP180	BMP180	Bosch	SENSOR PRESSURE ABS
119	U30	1	SeeedBLE	113050012	Seeed	Low cost ARM cortex-m0 based module for Bluetooth module
120	U35	1	LSM303DLHC	LSM303DLHC	ST Micro	ACCELEROMETER/MAGNETOMETER 14LGA
121	U36	1	LSM330DLC	LSM330DLC	ST Micro	ACCELEROMETER/MAGNETOMETER 28LGA
122	U37	1	M25P80	M25P80-VMW6G	Micron	IC FLASH 8MBIT 75MHZ 8SOW
123	U38	1	LIS2DS12	LIS2DS12TR	STMicroelectronics	MEMS DIGITAL OUTPUT MOTION SENSOR
124	U39	1	OVM7692	OVM7692-RAAA	OmniVision	SENSOR IMAGE
125	U41, U42	2	DG409LDQ-T1-E3	DG409LDQ-T1-E3	Vishay	2 Circuit IC Switch 4:1 29 Ohm 16-TSSOP

Item	Reference	Qty	Part	PART_NUMBER	Manufacturer	Description
126	U43	1	MAX9850	MAX9850ETI+T	Maxim Integrated	IC AMP AUDIO .095W STER 28TQFN
127	U44	1	AP7346D-1528FS6-7	AP7346D-1528FS6-7	Diodes	IC REG LDO 1.5V/2.8V X2-DFN1212
128	U90	1	MIC5335-SJYMT	MIC5335-SJYMT	Micrel	IC REG LDO 3.3V/2.5V 0.3A 6TMLF
129	U93	1	ESDR0502	ESDR0502NMUTBG	ON Semi	TVS DIODE 5.5VVM 6UDFN
130	U94, U95	2	MP34DB01	MP34DB01	STMicroelectronics	20Hz ~ 20kHz Digital, PDM Microphone MEMS (Silicon) 1.8V Omnidirectional (-26dB ±3dB @ 94dB SPL) Solder Pads
131	VCC_P, VCC_N	2	TP_S_40_63	—	—	Square test point, 40mil inner diameter, 63mil outer diameter
132	Y1	1	12MHz	ABM3-12.000MHZ-B2-T	Abracon Corp	CRYSTAL 12MHZ 18PF SMD
133	iCE40UP Mobile Development Platform Board PCB	1	—	305-PD-16-0605	PACTRON	—

Accessories

Item	Reference	Qty Per Board	Recommended Purchase Source	PART_NUMBER	Manufacturer	Description
1	LCD Display	1	www.vcdisplay.com - David Fontano / david@vcdisplay.com	LH154Q01-TD01	LG	http://vcdisplay.com/index.php/inventory/lg-display/lh154q01-td01-detail
2	Battery	1	http://www.ebay.com/itm/251766536585?_trksid=p2057872.m2749.l2649&ssPageName=STRK%3AMEBIDX%3AIT	S107-19 or 652030	Syma	3.7V 240mAh Li-Po Battery for SYMA S026 RC Remote Quadcopter
3	J17, J19, J25, J26, J27, J28	30	-	SPN02SXCN-RC	Sullins Connector Solutions	CONN JUMPER SHORTING 2MM GOLD

Revision History

Date	Version	Change Summary
October 2018	1.2	<p>Corrected part number to iCE40UP5K-UWG30 in the following sections:</p> <ul style="list-style-type: none"> • Features • Appendix A. iCE40 UltraPlus Mobile Development Board Schematics • Appendix B. iCE40 UltraPlus Mobile Development Board Bill of Materials
April 2018	1.1	<p>Updated Jumpers and Switches section.</p> <ul style="list-style-type: none"> • Corrected J25 description • Added J27
		<p>Updated jumpers in Figure 7.1. Board Configuration for Programming iCE40 UltraPlus Device “UI”.</p>
		<p>Added Table 7.2. iCE40 UltraPlus Device Selection Summary.</p>
		<p>Corrected step 1 (J19 setting changed to “vertically”) in Programming the iCE40 Devices Configuration Memory (CRAM) section.</p>
		<p>Updated Programming the iCE40 Devices Configuration Memory (CRAM) section.</p> <ul style="list-style-type: none"> • Corrected step 1 (J19 setting changed to “horizontally”) • Corrected step 7 figure reference for SPI Flash Options
		<p>Indicated operating range of BLE module in Bluetooth section.</p>
		<p>Added PCB Revision History section.</p>
		<p>Updated Appendix A. iCE40 UltraPlus Mobile Development Board Schematics.</p> <ul style="list-style-type: none"> • Changed schematics from Rev C to Rev D • Restored missing Sheet 13 • Changed figure numbering format • Made schematics searchable
		<p>Improved table format in Appendix B. iCE40 UltraPlus Mobile Development Board Bill of Materials</p>
		<p>Updated numbering of headings. Enhanced resolution of figures.</p>
May 2017	1.0	Initial release.



7th Floor, 111 SW 5th Avenue
Portland, OR 97204, USA
T 503.268.8000
www.latticesemi.com