

# FMB MB9A150RA Series

32-bit ARM™ Cortex™-M3 based Microcontroller  
MB9AF154MA/NA/RA, MB9AF155MA/NA/RA,  
MB9AF156MA/NA/RA

*Data Sheet (Full Production)*

---



**Notice to Readers:** This document states the current technical specifications regarding the Spansion product(s) described herein. Spansion Inc. deems the products to have been in sufficient production volume such that subsequent versions of this document are not expected to change. However, typographical or specification corrections, or modifications to the valid combinations offered may occur.

## Notice On Data Sheet Designations

Spansion Inc. issues data sheets with Advance Information or Preliminary designations to advise readers of product information or intended specifications throughout the product life cycle, including development, qualification, initial production, and full production. In all cases, however, readers are encouraged to verify that they have the latest information before finalizing their design. The following descriptions of Spansion data sheet designations are presented here to highlight their presence and definitions.

### Advance Information

The Advance Information designation indicates that Spansion Inc. is developing one or more specific products, but has not committed any design to production. Information presented in a document with this designation is likely to change, and in some cases, development on the product may discontinue.

Spansion Inc. therefore places the following conditions upon Advance Information content:

“This document contains information on one or more products under development at Spansion Inc. The information is intended to help you evaluate this product. Do not design in this product without contacting the factory. Spansion Inc. reserves the right to change or discontinue work on this proposed product without notice.”

### Preliminary

The Preliminary designation indicates that the product development has progressed such that a commitment to production has taken place. This designation covers several aspects of the product life cycle, including product qualification, initial production, and the subsequent phases in the manufacturing process that occur before full production is achieved. Changes to the technical specifications presented in a Preliminary document should be expected while keeping these aspects of production under consideration. Spansion places the following conditions upon Preliminary content:

“This document states the current technical specifications regarding the Spansion product(s) described herein. The Preliminary status of this document indicates that product qualification has been completed, and that initial production has begun. Due to the phases of the manufacturing process that require maintaining efficiency and quality, this document may be revised by subsequent versions or modifications due to changes in technical specifications.”

### Combination

Some data sheets contain a combination of products with different designations (Advance Information, Preliminary, or Full Production). This type of document distinguishes these products and their designations wherever necessary, typically on the first page, the ordering information page, and pages with the DC Characteristics table and the AC Erase and Program table (in the table notes). The disclaimer on the first page refers the reader to the notice on this page.

### Full Production (No Designation on Document)

When a product has been in production for a period of time such that no changes or only nominal changes are expected, the Preliminary designation is removed from the data sheet. Nominal changes may include those affecting the number of ordering part numbers available, such as the addition or deletion of a speed option, temperature range, package type, or VIO range. Changes may also include those needed to clarify a description or to correct a typographical error or incorrect specification.

Spansion Inc. applies the following conditions to documents in this category:

“This document states the current technical specifications regarding the Spansion product(s) described herein. Spansion Inc. deems the products to have been in sufficient production volume such that subsequent versions of this document are not expected to change. However, typographical or specification corrections, or modifications to the valid combinations offered may occur.”

Questions regarding these document designations may be directed to your local sales office.

# FM3 MB9A150RA Series

32-bit ARM™ Cortex™-M3 based Microcontroller  
MB9AF154MA/NA/RA, MB9AF155MA/NA/RA,  
MB9AF156MA/NA/RA

*Data Sheet (Full Production)*

---



## ■ DESCRIPTION

The MB9A150RA Series are highly integrated 32-bit microcontrollers dedicated for embedded controllers with low-power consumption mode and competitive cost.

These series are based on the ARM Cortex-M3 Processor with on-chip Flash memory and SRAM, and have peripheral functions such as various timers, ADCs, and Communication Interfaces (UART, CSIO, I<sup>2</sup>C).

The products which are described in this data sheet are placed into TYPE8 product categories in "FM3 Family PERIPHERAL MANUAL".

Note: ARM and Cortex are the trademarks of ARM Limited in the EU and other countries.



## ■ FEATURES

- 32-bit ARM Cortex-M3 Core
  - Processor version: r2p1
  - Up to 40 MHz Frequency Operation
  - Integrated Nested Vectored Interrupt Controller (NVIC): 1 NMI (non-maskable interrupt) and 48 peripheral interrupts and 16 priority levels
  - 24-bit System timer (Sys Tick): System timer for OS task management

- On-chip Memories

### [Flash memory]

- Dual operation Flash memory
  - Dual Operation Flash memory has the upper bank and the lower bank.  
So, this series could implement erase, write and read operations for each bank simultaneously.
  - Main area: Up to 512Kbytes (Upto 496Kbytes upper bank + 16Kbytes lower bank)
  - Work area: 32Kbytes (lower bank)
  - Read cycle: 0 wait-cycle
  - Security function for code protection

### [SRAM]

This Series on-chip SRAM is composed of two independent SRAM (SRAM0, SRAM1). SRAM0 is connected to I-code bus or D-code bus of Cortex-M3 core. SRAM1 is connected to System bus.

- SRAM0: Up to 32 Kbytes
- SRAM1: Up to 32 Kbytes

- External Bus Interface

- Supports SRAM, NOR NAND Flash memory device
- Up to 8 chip selects
- 8/16-bit Data width
- Up to 25-bit Address bit
- Maximum area size : Up to 256 Mbytes
- Supports Address/Data multiplex
- Supports external RDY function

- Multi-function Serial Interface (Max 16channels)

- 16 channels with 16steps×9-bit FIFO
- Operation mode is selectable from the followings for each channel.
  - UART
  - CSIO
  - I<sup>2</sup>C

### [UART]

- Full-duplex double buffer
- Selection with or without parity supported
- Built-in dedicated baud rate generator
- External clock available as a serial clock
- Hardware Flow control: Automatically control the transmission/reception by CTS/RTS (only ch.4)
- Various error detection functions available (parity errors, framing errors, and overrun errors)

### [CSIO]

- Full-duplex double buffer
- Built-in dedicated baud rate generator
- Overrun error detection function available

### [I<sup>2</sup>C]

Standard-mode (Max 100kbps) / Fast-mode (Max 400kbps) supported

- **DMA Controller (8channels)**

The DMA Controller has an independent bus from the CPU, so CPU and DMA Controller can process simultaneously.

  - 8 independently configured and operated channels
  - Transfer can be started by software or request from the built-in peripherals
  - Transfer address area: 32-bit (4 Gbytes)
  - Transfer mode: Block transfer/Burst transfer/Demand transfer
  - Transfer data type: byte/half-word/word
  - Transfer block count: 1 to 16
  - Number of transfers: 1 to 65536
  
- **A/D Converter (Max 24channels)**

[12-bit A/D Converter]

  - Successive Approximation type
  - Built-in 2units
  - Conversion time: 2.0 $\mu$ s @ 2.7V to 3.6V
  - Priority conversion available (priority at 2levels)
  - Scanning conversion mode
  - Built-in FIFO for conversion data storage (for SCAN conversion: 16steps, for Priority conversion: 4steps)
  
- **Base Timer (Max 16channels)**

Operation mode is selectable from the followings for each channel.

  - 16-bit PWM timer
  - 16-bit PPG timer
  - 16/32-bit reload timer
  - 16/32-bit PWC timer
  
- **General-Purpose I/O Port**

This series can use its pins as general-purpose I/O ports when they are not used for external bus or peripherals. Moreover, the port relocate function is built in. It can set which I/O port the peripheral function can be allocated to.

  - Capable of pull-up control per pin
  - Capable of reading pin level directly
  - Built-in the port relocate function
  - Up to 103 high-speed general-purpose I/O Ports@120pin Package
  - Some ports are 5V tolerant I/O

See "■ LIST OF PIN FUNCTIONS" and "■ I/O CIRCUIT TYPE" to confirm the corresponding pins.
  
- **Dual Timer (32/16-bit Down Counter)**

The Dual Timer consists of two programmable 32/16-bit down counters.  
Operation mode is selectable from the followings for each channel.

  - Free-running
  - Periodic (=Reload)
  - One-shot

- **Multi-function Timer**

The Multi-function timer is composed of the following blocks.

- 16-bit free-run timer × 3ch.
- Input capture × 4ch.
- Output compare × 6ch.
- A/D activation compare × 2ch.
- Waveform generator × 3ch.
- 16-bit PPG timer × 3ch.

The following function can be used to achieve the motor control.

- PWM signal output function
- DC chopper waveform output function
- Dead time function
- Input capture function
- A/D convertor activate function
- DTIF (Motor emergency stop) interrupt function

- **Quadrature Position/Revolution Counter (QPRC)**

The Quadrature Position/Revolution Counter (QPRC) is used to measure the position of the position encoder. Moreover, it is possible to use as the up/down counter.

- The detection edge of the three external event input pins AIN, BIN and ZIN is configurable.
- 16-bit position counter
- 16-bit revolution counter
- Two 16-bit compare registers

- **HDMI-CEC/Remote Control Reception (Up to 2channels)**

- HDMI-CEC transmission
  - Header block automatic transmission by judging Signal free
  - Generating status interrupt by detecting Arbitration lost
  - Generating START, EOM, ACK automatically to output CEC transmission by setting 1 byte data
  - Generating transmission status interrupt when transmitting 1 block (1 byte data and EOM/ACK)
- HDMI-CEC reception
  - Automatic ACK reply function available
  - Line error detection function available
- Remote control reception
  - 4 bytes reception buffer
  - Repeat code detection function available

- **Real-time clock (RTC)**

The Real-time clock can count Year/Month/Day/Hour/Minute/Second/A day of the week from 01 to 99.

- The interrupt function with specifying date and time (Year/Month/Day/Hour/Minute/Second/A day of the week.) is available. This function is also available by specifying only Year, Month, Day, Hour or Minute.
- Timer interrupt function after set time or each set time.
- Capable of rewriting the time with continuing the time count.
- Leap year automatic count is available.

- **Watch Counter**

The Watch counter is used for wake up from sleep and timer mode.

Interval timer: up to 64s (Max) @ Sub Clock : 32.768 kHz

- External Interrupt Controller Unit
  - Up to 24 external interrupt input pins
  - Include one non-maskable interrupt (NMI) input pin

- Watchdog Timer (2channels)

A watchdog timer can generate interrupts or a reset when a time-out value is reached.

This series consists of two different watchdogs, a "Hardware" watchdog and a "Software" watchdog.

The "Hardware" watchdog timer is clocked by the built-in low-speed CR oscillator. Therefore, the "Hardware" watchdog is active in any low-power consumption modes except RTC, STOP, Deep standby RTC and Deep standby STOP modes.

- CRC (Cyclic Redundancy Check) Accelerator

The CRC accelerator calculates the CRC which has a heavy software processing load, and achieves a reduction of the integrity check processing load for reception data and storage.

CCITT CRC16 and IEEE-802.3 CRC32 are supported.

- CCITT CRC16 Generator Polynomial: 0x1021
- IEEE-802.3 CRC32 Generator Polynomial: 0x04C11DB7

- Clock and Reset

[Clocks]

Selectable from five clock sources (2 external oscillators, 2 built-in CR oscillators, and Main PLL).

- Main Clock : 4 MHz to 48 MHz
- Sub Clock : 32.768 kHz
- Built-in high-speed CR Clock : 4 MHz
- Built-in low-speed CR Clock : 100 kHz
- Main PLL Clock

[Resets]

- Reset requests from INITX pin
- Power-on reset
- Software reset
- Watchdog timers reset
- Low-voltage detection reset
- Clock Super Visor reset

- Clock Super Visor (CSV)

Clocks generated by built-in CR oscillators are used to supervise abnormality of the external clocks.

- If external clock failure (clock stop) is detected, reset is asserted.
- If external frequency anomaly is detected, interrupt or reset is asserted.

- Low-Voltage Detector (LVD)

This Series includes 2-stage monitoring of voltage on the VCC pins. When the voltage falls below the voltage that has been set, Low-Voltage Detector generates an interrupt or reset.

- LVD1: error reporting via interrupt
- LVD2: auto-reset operation

- **Low-Power Consumption Mode**  
Six low-power consumption modes supported.
  - SLEEP
  - TIMER
  - RTC
  - STOP
  - Deep standby RTC (selectable between keeping the value of RAM and not)
  - Deep standby STOP (selectable between keeping the value of RAM and not)
  
- **Debug**
  - Serial Wire JTAG Debug Port (SWJ-DP)
  - Embedded Trace Macrocells (ETM).\*

\*: MB9AF154MA, F155MA and F156MA support only SWJ-DP.
  
- **Unique ID**  
Unique value of the device (41-bit) is set.
  
- **Power Supply**  
Wide range voltage: VCC = 1.65V to 3.6V



**■ PRODUCT LINEUP**

## • Memory size

Product name		MB9AF154MA/NA/RA	MB9AF155MA/NA/RA	MB9AF156MA/NA/RA
On-chip Flash memory	Main area	256 Kbytes	384 Kbytes	512 Kbytes
	Work area	32 Kbytes	32 Kbytes	32 Kbytes
On-chip SRAM	SRAM0	16 Kbytes	24 Kbytes	32 Kbytes
	SRAM1	16 Kbytes	24 Kbytes	32 Kbytes
	Total	32 Kbytes	48 Kbytes	64 Kbytes

● Function

Product name		MB9AF154MA MB9AF155MA MB9AF156MA	MB9AF154NA MB9AF155NA MB9AF156NA	MB9AF154RA MB9AF155RA MB9AF156RA
Pin count		80/96	100/112	120
CPU		Cortex-M3		
Freq.		40 MHz		
Power supply voltage range		1.65V to 3.6V		
DMAC		8ch.		
External Bus Interface		Addr: 21-bit (Max) R/W Data: 8-bit (Max) CS: 4 (Max) Support: SRAM, NOR Flash memory	Addr: 25-bit (Max) R/W Data: 8/16-bit (Max) CS: 8 (Max) Support: SRAM, NOR Flash memory	Addr: 25-bit (Max) R/W Data: 8/16-bit (Max) CS: 8 (Max) Support: SRAM, NOR Flash memory, NAND Flash memory
Multi-function Serial Interface (UART/CSIO/I <sup>2</sup> C)		10ch. (Max) Enabled channels : ch.0 to ch.7, ch.10, ch.11	14ch. (Max) Enabled channels : ch.0 to ch.13	16ch. (Max) Enabled channels : ch.0 to ch.15
Base Timer (PWC/Reload timer/PWM/PPG)		16ch. (Max)		
MF- Timer	A/D activation compare	2ch.	1 unit (Max)	
	Input capture	4ch.		
	Free-run timer	3ch.		
	Output compare	6ch.		
	Waveform generator	3ch.		
	PPG	3ch.		
QPRC		2ch. (Max)		
Dual Timer		1 unit		
HDMI-CEC/ Remote Control Reception		2ch. (Max)		
Real-Time Clock		1 unit		
Watch Counter		1 unit		
CRC Accelerator		Yes		
Watchdog timer		1ch. (SW) + 1ch. (HW)		
External Interrupts		23pins (Max) + NMI × 1	24pins (Max) + NMI × 1	
I/O ports		66pins (Max)	83pins (Max)	103pins (Max)
12-bit A/D converter		17ch. (2 units)	24ch. (2 units)	
CSV (Clock Super Visor)		Yes		
LVD (Low-Voltage Detector)		2ch.		
Built-in CR	High-speed	4 MHz		
	Low-speed	100 kHz		
Debug Function		SWJ-DP	SWJ-DP/ETM	
Unique ID		Yes		

Note: All signals of the peripheral function in each product cannot be allocated by limiting the pins of package.

It is necessary to use the port relocate function of the I/O port according to your function use.

See "■ ELECTRICAL CHARACTERISTICS 4.AC Characteristics (3)Built-in CR Oscillation Characteristics" for accuracy of built-in CR.

## ■ PACKAGES

Package	Product name	MB9AF154MA	MB9AF154NA	MB9AF154RA
		MB9AF155MA	MB9AF155NA	MB9AF155RA
		MB9AF156MA	MB9AF156NA	MB9AF156RA
LQFP: FPT-80P-M37 (0.5mm pitch)		○	-	-
BGA: BGA-96P-M07 (0.5mm pitch)		○	-	-
LQFP: FPT-100P-M23 (0.5mm pitch)		-	○	-
BGA: BGA-112P-M04 (0.8mm pitch)		-	○	-
LQFP: FPT-120P-M37 (0.5mm pitch)		-	-	○

○ : Supported

Note: See "■PACKAGE DIMENSIONS" for detailed information on each package.

## PIN ASSIGNMENT

### FPT-120P-M37

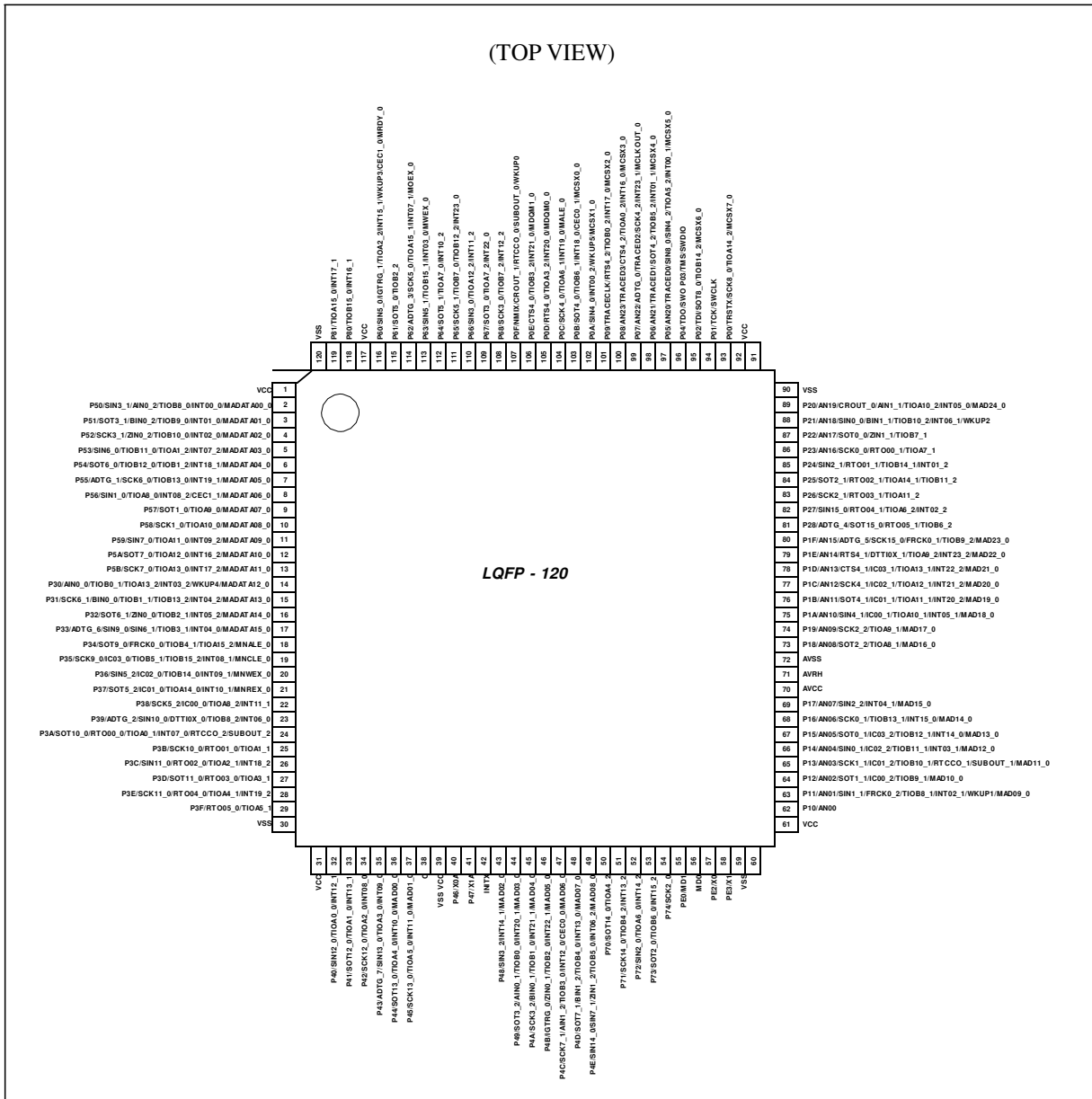

### <Note>

The number after the underscore ("\_") in pin names such as XXX\_1 and XXX\_2 indicates the relocated port number. For these pins, there are multiple pins that provide the same function for the same channel. Use the extended port function register (EPFR) to select the pin.

• FPT-100P-M23

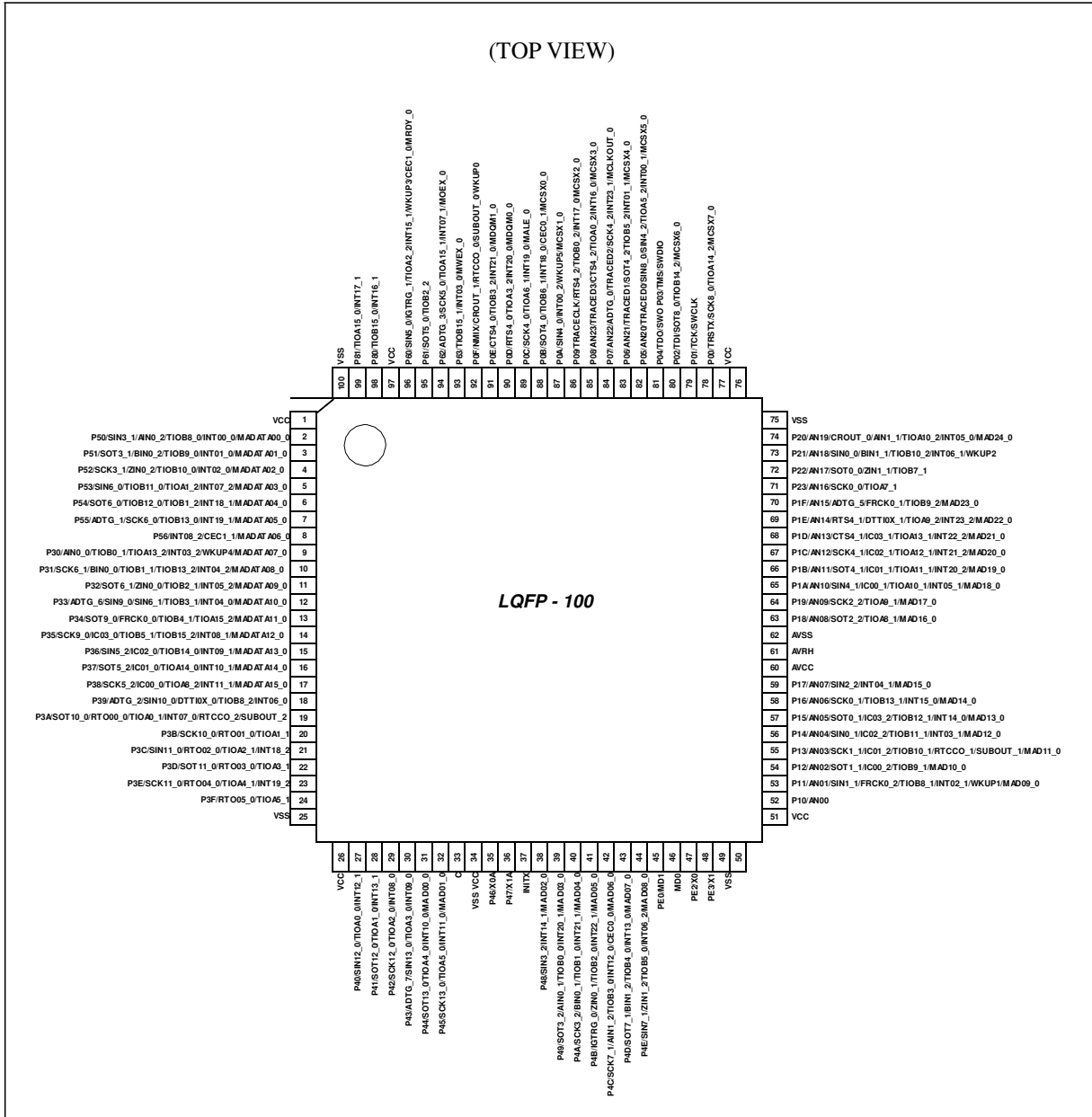

<Note>

The number after the underscore ("\_") in pin names such as XXX\_1 and XXX\_2 indicates the relocated port number. For these pins, there are multiple pins that provide the same function for the same channel. Use the extended port function register (EPFR) to select the pin.

• FPT-80P-M37

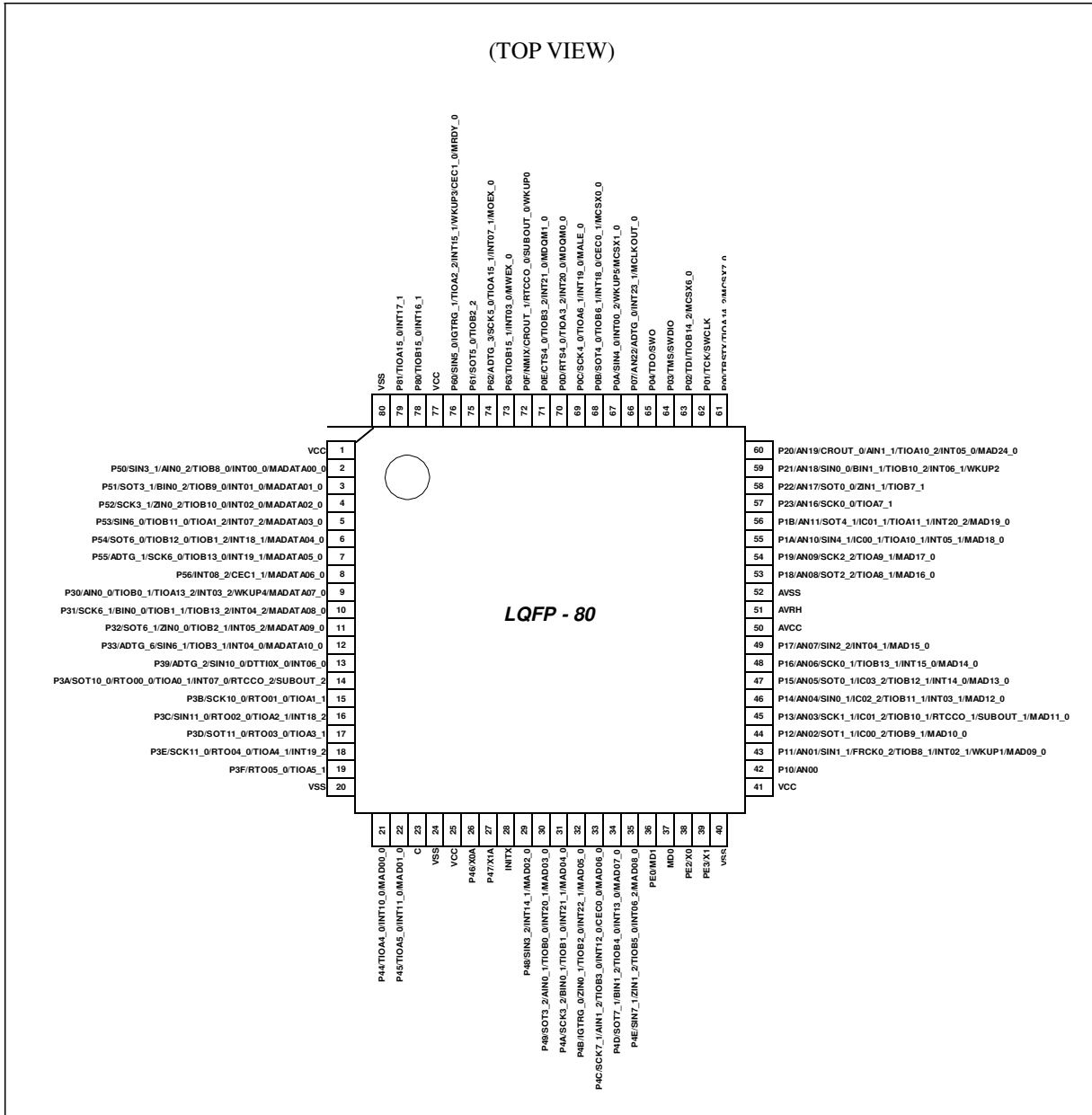

<Note>

The number after the underscore ("\_") in pin names such as XXX\_1 and XXX\_2 indicates the relocated port number. For these pins, there are multiple pins that provide the same function for the same channel. Use the extended port function register (EPFR) to select the pin.

• BGA-112P-M04

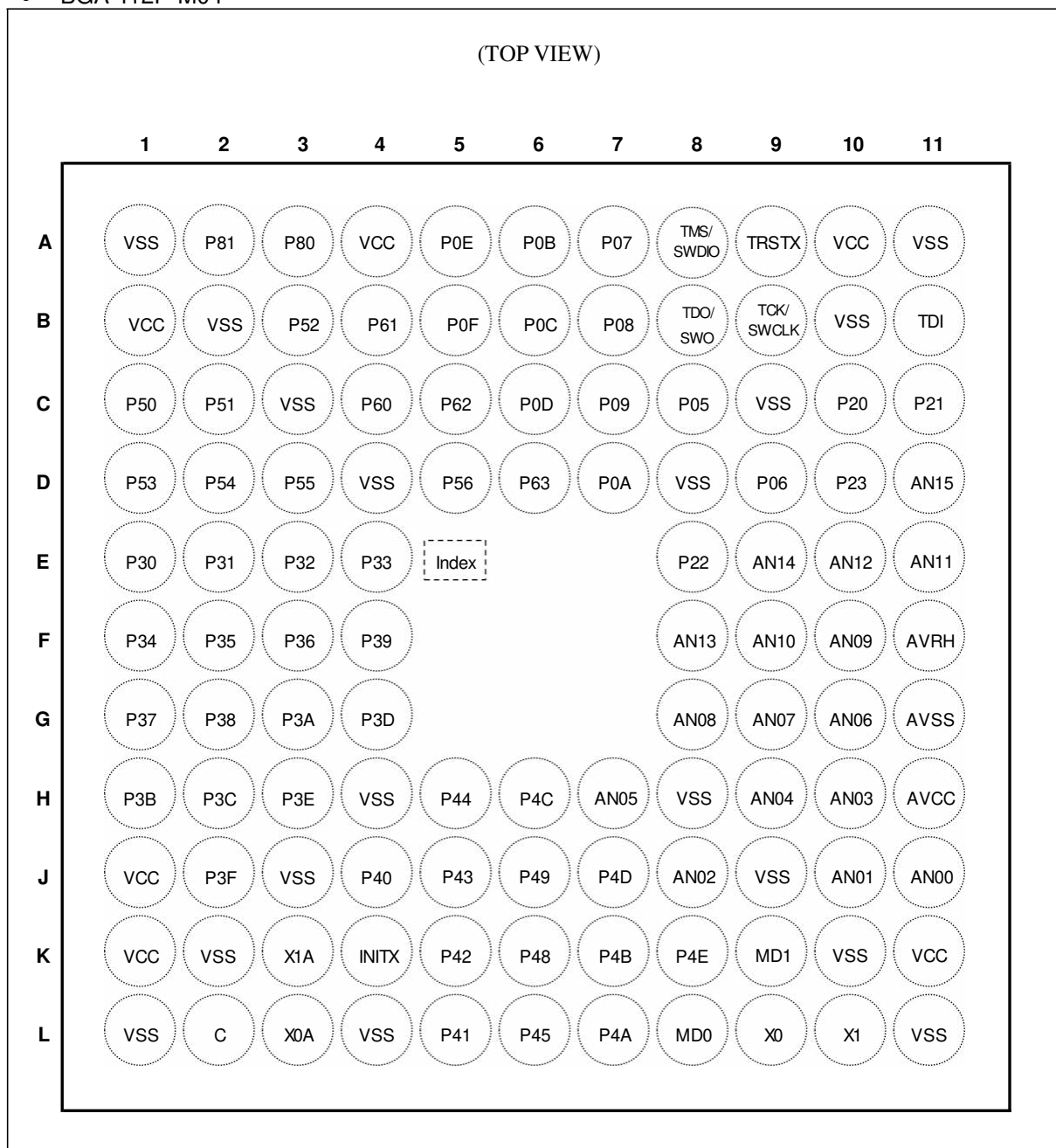

**<Note>**

The number after the underscore ("\_") in pin names such as XXX\_1 and XXX\_2 indicates the relocated port number. For these pins, there are multiple pins that provide the same function for the same channel. Use the extended port function register (EPFR) to select the pin.

• BGA-96P-M07

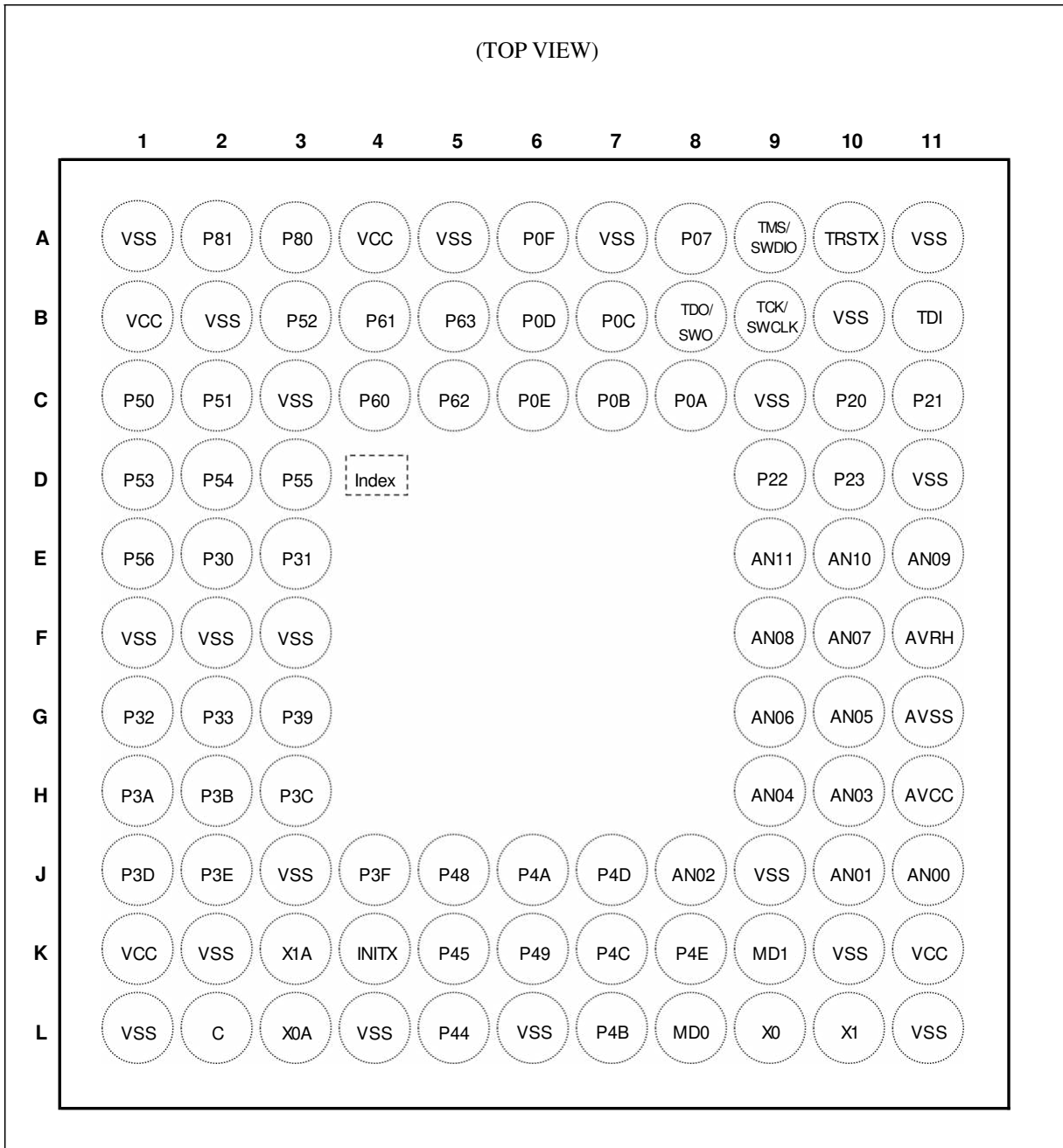

**<Note>**

The number after the underscore ("\_") in pin names such as XXX\_1 and XXX\_2 indicates the relocated port number. For these pins, there are multiple pins that provide the same function for the same channel. Use the extended port function register (EPFR) to select the pin.



## ■ LIST OF PIN FUNCTION

### • List of pin numbers

The number after the underscore ("\_") in pin names such as XXX\_1 and XXX\_2 indicates the relocated port number. For these pins, there are multiple pins that provide the same function for the same channel. Use the extended port function register (EPFR) to select the pin.

Pin No					Pin Name	I/O circuit type	Pin state type
LQFP-120	LQFP-100	BGA-112	LQFP-80	BGA-96			
1	1	B1	1	B1	VCC	-	
2	2	C1	2	C1	P50	E	K
					SIN3_1		
					AIN0_2		
					TIOB8_0		
					INT00_0		
					MADATAA00_0		
3	3	C2	3	C2	P51	E	K
					SOT3_1 (SDA3_1)		
					BIN0_2		
					TIOB9_0		
					INT01_0		
					MADATAA01_0		
4	4	B3	4	B3	P52	E	K
					SCK3_1 (SCL3_1)		
					ZIN0_2		
					TIOB10_0		
					INT02_0		
					MADATAA02_0		
5	5	D1	5	D1	P53	E	K
					SIN6_0		
					TIOB11_0		
					TIOA1_2		
					INT07_2		
					MADATAA03_0		
6	6	D2	6	D2	P54	E	K
					SOT6_0 (SDA6_0)		
					TIOB12_0		
					TIOB1_2		
					INT18_1		
					MADATAA04_0		
7	7	D3	7	D3	P55	E	K
					ADTG_1		
					SCK6_0 (SCL6_0)		
					TIOB13_0		
					INT19_1		
					MADATAA05_0		

Pin No					Pin Name	I/O circuit type	Pin state type
LQFP-120	LQFP-100	BGA-112	LQFP-80	BGA-96			
8	8	D5	8	E1	P56	H*	R
					INT08_2		
					CEC1_1		
					MADATA06_0		
	-	-	-	-	SIN1_0		
	-	-	-	-	TIOA8_0		
9	-	-	-	-	P57	H*	J
					SOT1_0 (SDA1_0)		
					TIOA9_0		
					MADATA07_0		
10	-	-	-	-	P58	H*	J
					SCK1_0 (SCL1_0)		
					TIOA10_0		
					MADATA08_0		
11	-	-	-	-	P59	E	K
					SIN7_0		
					TIOA11_0		
					INT09_2		
					MADATA09_0		
12	-	-	-	-	P5A	E	K
					SOT7_0 (SDA7_0)		
					TIOA12_0		
					INT16_2		
					MADATA10_0		
13	-	-	-	-	P5B	E	K
					SCK7_0 (SCL7_0)		
					TIOA13_0		
					INT17_2		
					MADATA11_0		
14	-	-	-	-	P30	E	S
					AIN0_0		
					TIOB0_1		
					TIOA13_2		
					INT03_2		
					WKUP4		
					MADATA12_0		
-	9	E1	9	E2	P30	E	S
					AIN0_0		
					TIOB0_1		
					TIOA13_2		
					INT03_2		
					WKUP4		
					MADATA07_0		

Pin No					Pin Name	I/O circuit type	Pin state type
LQFP-120	LQFP-100	BGA-112	LQFP-80	BGA-96			
15	-	-	-	-	P31	E	K
					SCK6_1 (SCL6_1)		
					BIN0_0		
					TIOB1_1		
					TIOB13_2		
					INT04_2		
					MADATA13_0		
-	10	E2	10	E3	P31	E	K
					SCK6_1 (SCL6_1)		
					BIN0_0		
					TIOB1_1		
					TIOB13_2		
					INT04_2		
					MADATA08_0		
16	-	-	-	-	P32	E	K
					SOT6_1 (SDA6_1)		
					ZIN0_0		
					TIOB2_1		
					INT05_2		
					MADATA14_0		
-	11	E3	11	G1	P32	E	K
					SOT6_1 (SDA6_1)		
					ZIN0_0		
					TIOB2_1		
					INT05_2		
					MADATA09_0		
17	-	-	-	-	P33	E	K
					ADTG_6		
					SIN9_0		
					SIN6_1		
					TIOB3_1		
					INT04_0		
					MADATA15_0		
-	12	E4	12	G2	P33	E	K
					ADTG_6		
					SIN6_1		
					TIOB3_1		
					INT04_0		
					MADATA10_0		
			-	-	SIN9_0		

Pin No					Pin Name	I/O circuit type	Pin state type
LQFP-120	LQFP-100	BGA-112	LQFP-80	BGA-96			
18	-	-	-	-	P34	E	J
					SOT9_0 (SDA9_0)		
					FRCK0_0		
					TIOB4_1		
					TIOA15_2		
MNALE_0							
-	13	F1	-	-	P34	E	J
					SOT9_0 (SDA9_0)		
					FRCK0_0		
					TIOB4_1		
					TIOA15_2		
MADATA11_0							
19	-	-	-	-	P35	E	K
					SCK9_0 (SCL9_0)		
					IC03_0		
					TIOB5_1		
					TIOB15_2		
					INT08_1		
MNCLE_0							
-	14	F2	-	-	P35	E	K
					SCK9_0 (SCL9_0)		
					IC03_0		
					TIOB5_1		
					TIOB15_2		
					INT08_1		
MADATA12_0							
20	-	-	-	-	P36	E	K
					SIN5_2		
					IC02_0		
					TIOB14_0		
					INT09_1		
					MNWEX_0		
-	15	F3	-	-	P36	E	K
					SIN5_2		
					IC02_0		
					TIOB14_0		
					INT09_1		
					MADATA13_0		
-	-	-	-	F1	VSS	-	-
-	-	-	-	F2	VSS	-	-
-	-	-	-	F3	VSS	-	-

Pin No					Pin Name	I/O circuit type	Pin state type
LQFP-120	LQFP-100	BGA-112	LQFP-80	BGA-96			
21	-	-	-	-	P37	E	K
					SOT5_2 (SDA5_2)		
					IC01_0		
					TIOA14_0		
					INT10_1		
MNREX_0							
-	16	G1	-	-	P37	E	K
					SOT5_2 (SDA5_2)		
					IC01_0		
					TIOA14_0		
					INT10_1		
MADATA14_0							
22	17	G2	-	-	P38	E	K
					SCK5_2 (SCL5_2)		
					IC00_0		
					TIOA08_2		
					INT11_1		
MADATA15_0							
-							
23	18	F4	13	G3	P39	E	K
					ADTG_2		
			SIN10_0				
			DTTIOX_0				
			INT06_0				
-			-	-	TIOB8_2		
24	19	G3	14	H1	P3A	E	K
					SOT10_0 (SDA10_0)		
					RTO00_0		
					TIOA0_1		
					INT07_0		
					RTCCO_2		
SUBOUT_2							
25	20	H1	15	H2	P3B	E	J
					SCK10_0 (SCL10_0)		
					RTO01_0		
TIOA1_1							
26	21	H2	16	H3	P3C	E	K
					SIN11_0		
					RTO02_0		
					TIOA2_1		
INT18_2							

Pin No					Pin Name	I/O circuit type	Pin state type
LQFP-120	LQFP-100	BGA-112	LQFP-80	BGA-96			
27	22	G4	17	J1	P3D	E	J
					SOT11_0 (SDA11_0)		
					RTO03_0		
					TIOA3_1		
-	-	B2	-	B2	VSS	-	
28	23	H3	18	J2	P3E	E	K
					SCK11_0 (SCL11_0)		
					RTO04_0		
					TIOA4_1		
					INT19_2		
29	24	J2	19	J4	P3F	E	J
					RTO05_0		
					TIOA5_1		
30	25	L1	20	L1	VSS	-	
31	26	J1	-	-	VCC	-	
32	27	J4	-	-	P40	E	K
					SIN12_0		
					TIOA0_0		
					INT12_1		
33	28	L5	-	-	P41	E	K
					SOT12_0 (SDA12_0)		
					TIOA1_0		
					INT13_1		
34	29	K5	-	-	P42	E	K
					SCK12_0 (SCL12_0)		
					TIOA2_0		
					INT08_0		
35	30	J5	-	-	P43	E	K
					ADTG_7		
					SIN13_0		
					TIOA3_0		
					INT09_0		
36	31	H5	21	L5	P44	E	K
			-	-	SOT13_0 (SDA13_0)		
			21	L5	TIOA4_0		
					INT10_0		
					MAD00_0		
37	32	L6	22	K5	P45	E	K
			-	-	SCK13_0		
			22	K5	TIOA5_0		
					INT11_0		
					MAD01_0		

Pin No					Pin Name	I/O circuit type	Pin state type
LQFP-120	LQFP-100	BGA-112	LQFP-80	BGA-96			
-	-	K2	-	K2	VSS	-	
-	-	J3	-	J3	VSS	-	
-	-	H4	-	-	VSS	-	
-	-	-	-	L6	VSS	-	
38	33	L2	23	L2	C	-	
39	34	L4	24	L4	VSS	-	
40	35	K1	25	K1	VCC	-	
41	36	L3	26	L3	P46	D	F
					X0A		
42	37	K3	27	K3	P47	D	G
					X1A		
43	38	K4	28	K4	INITX	B	C
44	39	K6	29	J5	P48	E	K
					SIN3_2		
					INT14_1		
					MAD02_0		
45	40	J6	30	K6	P49	E	K
					SOT3_2 (SDA3_2)		
					AIN0_1		
					TIOB0_0		
					INT20_1		
MAD03_0							
46	41	L7	31	J6	P4A	E	K
					SCK3_2 (SCL3_2)		
					BIN0_1		
					TIOB1_0		
					INT21_1		
MAD04_0							
47	42	K7	32	L7	P4B	E	K
					IGTRG_0		
					ZIN0_1		
					TIOB2_0		
					INT22_1		
MAD05_0							
48	43	H6	33	K7	P4C	H*	R
					SCK7_1 (SCL7_1)		
					AIN1_2		
					TIOB3_0		
					INT12_0		
					CEC0_0		
MAD06_0							

Pin No					Pin Name	I/O circuit type	Pin state type
LQFP-120	LQFP-100	BGA-112	LQFP-80	BGA-96			
49	44	J7	34	J7	P4D	H*	K
					SOT7_1 (SDA7_1)		
					BIN1_2		
					TIOB4_0		
					INT13_0		
MAD07_0							
50	45	K8	35	K8	P4E	H*	K
					SIN7_1		
					ZIN1_2		
					TIOB5_0		
					INT06_2		
	MAD08_0						
-	-	-	-	-	SIN14_0		
51	-	-	-	-	P70	E	J
					SOT14_0 (SDA14_0)		
					TIOA4_2		
52	-	-	-	-	P71	E	K
					SCK14_0 (SCL14_0)		
					TIOB4_2		
					INT13_2		
53	-	-	-	-	P72	E	K
					SIN2_0		
					TIOA6_0		
					INT14_2		
54	-	-	-	-	P73	E	K
					SOT2_0 (SDA2_0)		
					TIOB6_0		
					INT15_2		
55	-	-	-	-	P74	E	J
					SCK2_0 (SCL2_0)		
56	46	K9	36	K9	MD1	C	E
					PE0		
57	47	L8	37	L8	MD0	G	D
58	48	L9	38	L9	X0	A	A
					PE2		
59	49	L10	39	L10	X1	A	B
					PE3		
60	50	L11	40	L11	VSS	-	
61	51	K11	41	K11	VCC	-	
62	52	J11	42	J11	P10	F	L
					AN00		



Pin No					Pin Name	I/O circuit type	Pin state type
LQFP-120	LQFP-100	BGA-112	LQFP-80	BGA-96			
63	53	J10	43	J10	P11	F	P
					AN01		
					SIN1_1		
					FRCK0_2		
					TIOB8_1		
					INT02_1		
					WKUP1		
MAD09_0							
64	54	J8	44	J8	P12	F	L
					AN02		
					SOT1_1 (SDA1_1)		
					IC00_2		
					TIOB9_1		
MAD10_0							
-	-	K10	-	K10	VSS	-	-
-	-	J9	-	J9	VSS	-	-
65	55	H10	45	H10	P13	F	L
					AN03		
					SCK1_1 (SCL1_1)		
					IC01_2		
					TIOB10_1		
					RTCCO_1		
					SUBOUT_1		
MAD11_0							
66	56	H9	46	H9	P14	F	M
					AN04		
					SIN0_1		
					IC02_2		
					TIOB11_1		
					INT03_1		
MAD12_0							
67	57	H7	47	G10	P15	F	M
					AN05		
					SOT0_1 (SDA0_1)		
					IC03_2		
					TIOB12_1		
					INT14_0		
MAD13_0							

Pin No					Pin Name	I/O circuit type	Pin state type
LQFP-120	LQFP-100	BGA-112	LQFP-80	BGA-96			
68	58	G10	48	G9	P16	F	M
					AN06		
					SCK0_1 (SCL0_1)		
					TIOB13_1		
					INT15_0		
					MAD14_0		
69	59	G9	49	F10	P17	F	M
					AN07		
					SIN2_2		
					INT04_1		
					MAD15_0		
70	60	H11	50	H11	AVCC	-	
71	61	F11	51	F11	AVRH	-	
72	62	G11	52	G11	AVSS	-	
73	63	G8	53	F9	P18	F	L
					AN08		
					SOT2_2 (SDA2_2)		
					TIOA8_1		
					MAD16_0		
74	64	F10	54	E11	P19	F	L
					AN09		
					SCK2_2 (SCL2_2)		
					TIOA9_1		
					MAD17_0		
-	-	H8	-	-	VSS	-	
75	65	F9	55	E10	P1A	F	M
					AN10		
					SIN4_1		
					IC00_1		
					TIOA10_1		
					INT05_1		
					MAD18_0		
76	66	E11	56	E9	P1B	F	M
					AN11		
					SOT4_1 (SDA4_1)		
					IC01_1		
					TIOA11_1		
					INT20_2		
					MAD19_0		

Pin No					Pin Name	I/O circuit type	Pin state type
LQFP-120	LQFP-100	BGA-112	LQFP-80	BGA-96			
77	67	E10	-	-	P1C	F	M
					AN12		
					SCK4_1 (SCL4_1)		
					IC02_1		
					TIOA12_1		
					INT21_2		
					MAD20_0		
78	68	F8	-	-	P1D	F	M
					AN13		
					CTS4_1		
					IC03_1		
					TIOA13_1		
					INT22_2		
					MAD21_0		
79	69	E9	-	-	P1E	F	M
					AN14		
					RTS4_1		
					DTTIOX_1		
					TIOA9_2		
					INT23_2		
					MAD22_0		
80	70	D11	-	-	P1F	F	L
					AN15		
					ADTG_5		
					FRCK0_1		
					TIOB9_2		
					MAD23_0		
	-	-	-	-	-		
-	-	B10	-	B10	VSS	-	
-	-	C9	-	C9	VSS	-	
-	-	-	-	D11	VSS	-	
81	-	-	-	-	P28	E	J
					ADTG_4		
					SOT15_0 (SDA15_0)		
					RTO05_1		
					TIOB6_2		
82	-	-	-	-	P27	E	K
					SIN15_0		
					RTO04_1		
					TIOA6_2		
					INT02_2		

Pin No					Pin Name	I/O circuit type	Pin state type
LQFP-120	LQFP-100	BGA-112	LQFP-80	BGA-96			
83	-	-	-	-	P26	E	J
					SCK2_1 (SCL2_1)		
					RTO03_1		
					TIOA11_2		
84	-	-	-	-	P25	E	J
					SOT2_1 (SDA2_1)		
					RTO02_1		
					TIOA14_1		
					TIOB11_2		
85	-	-	-	-	P24	E	K
					SIN2_1		
					RTO01_1		
					TIOB14_1		
					INT01_2		
86	71	D10	57	D10	P23	F	L
	-	-	-	-	AN16		
					SCK0_0 (SCL0_0)		
					TIOA7_1		
					RTO00_1		
87	72	E8	58	D9	P22	F	L
					AN17		
					SOT0_0 (SDA0_0)		
					ZIN1_1		
					TIOB7_1		
88	73	C11	59	C11	P21	F	P
					AN18		
					SIN0_0		
					BIN1_1		
					TIOB10_2		
					INT06_1		
					WKUP2		
89	74	C10	60	C10	P20	F	M
					AN19		
					CROUT_0		
					AIN1_1		
					TIOA10_2		
					INT05_0		
					MAD24_0		
90	75	A11	-	A11	VSS	-	-
91	76	A10	-	-	VCC	-	-

Pin No					Pin Name	I/O circuit type	Pin state type
LQFP-120	LQFP-100	BGA-112	LQFP-80	BGA-96			
92	77	A9	61	A10	P00	E	I
					TRSTX		
			TIOA14_2				
			MCSX7_0				
			-	-	SCK8_0 (SCL8_0)		
93	78	B9	62	B9	P01	E	I
					TCK		
					SWCLK		
94	79	B11	63	B11	P02	E	I
					TDI		
					TIOB14_2		
			MCSX6_0				
			-	-	SOT8_0		
95	80	A8	64	A9	P03	E	I
					TMS		
					SWDIO		
96	81	B8	65	B8	P04	E	I
					TDO		
					SWO		
97	82	C8	-	-	P05	F	O
					AN20		
					TRACED0		
					SIN8_0		
					SIN4_2		
					TIOA5_2		
					INT00_1		
MCSX5_0							
-	-	D8	-	-	VSS	-	
98	83	D9	-	-	P06	F	O
					AN21		
					TRACED1		
					SOT4_2 (SDA4_2)		
					TIOB5_2		
					INT01_1		
					MCSX4_0		
99	84	A7	66	A8	P07	F	O
					AN22		
					ADTG_0		
			MCLKOUT_0				
			INT23_1				
			TRACED2				
			SCK4_2 (SCL4_2)				
-	-	-	-	A7	VSS	-	

Pin No					Pin Name	I/O circuit type	Pin state type
LQFP-120	LQFP-100	BGA-112	LQFP-80	BGA-96			
100	85	B7	-	-	P08	F	O
					AN23		
					TRACED3		
					CTS4_2		
					TIOA0_2		
					INT16_0		
					MCSX3_0		
101	86	C7	-	-	P09	E	N
					TRACECLK		
					RTS4_2		
					TIOB0_2		
					INT17_0		
					MCSX2_0		
102	87	D7	67	C8	P0A	H*	S
					SIN4_0		
					INT00_2		
					WKUP5		
					MCSX1_0		
103	88	A6	68	C7	P0B	H*	R
					SOT4_0 (SDA4_0)		
					TIOB6_1		
					INT18_0		
					CEC0_1		
					MCSX0_0		
104	89	B6	69	B7	P0C	H*	K
					SCK4_0 (SCL4_0)		
					TIOA6_1		
					INT19_0		
					MALE_0		
-	-	D4	-	-	VSS	-	-
-	-	C3	-	C3	VSS	-	-
105	90	C6	70	B6	P0D	E	K
					RTS4_0		
					TIOA3_2		
					INT20_0		
					MDQM0_0		
106	91	A5	71	C6	P0E	E	K
					CTS4_0		
					TIOB3_2		
					INT21_0		
					MDQM1_0		
-	-	-	-	A5	VSS	-	-

Pin No					Pin Name	I/O circuit type	Pin state type
LQFP-120	LQFP-100	BGA-112	LQFP-80	BGA-96			
107	92	B5	72	A6	P0F	E	H
					NMIX		
					CROUT_1		
					RTCCO_0		
					SUBOUT_0		
					WKUP0		
108	-	-	-	-	P68	E	K
					SCK3_0 (SCL3_0)		
					TIOB7_2		
					INT12_2		
109	-	-	-	-	P67	E	K
					SOT3_0 (SDA3_0)		
					TIOA7_2		
110	-	-	-	-	P66	E	K
					SIN3_0		
					TIOA12_2		
					INT11_2		
111	-	-	-	-	P65	E	K
					SCK5_1 (SCL5_1)		
					TIOB7_0		
					TIOB12_2		
					INT23_0		
112	-	-	-	-	P64	E	K
					SOT5_1 (SDA5_1)		
					TIOA7_0		
					INT10_2		
113	93	D6	73	B5	P63	E	K
					TIOB15_1		
					INT03_0		
					MWEX_0		
	-	-	-	-	SIN5_1		
114	94	C5	74	C5	P62	E	K
					ADTG_3		
					SCK5_0 (SCL5_0)		
					TIOA15_1		
					INT07_1		
					MOEX_0		

Pin No					Pin Name	I/O circuit type	Pin state type
LQFP-120	LQFP-100	BGA-112	LQFP-80	BGA-96			
115	95	B4	75	B4	P61	E	J
					SOT5_0 (SDA5_0)		
					TIOB2_2		
116	96	C4	76	C4	P60	H*	Q
					SIN5_0		
					IGTRG_1		
					TIOA2_2		
					INT15_1		
					WKUP3		
					CEC1_0		
MRDY_0							
117	97	A4	77	A4	VCC	-	
118	98	A3	78	A3	P80	E	K
					TIOB15_0		
					INT16_1		
119	99	A2	79	A2	P81	E	K
					TIOA15_0		
					INT17_1		
120	100	A1	80	A1	VSS	-	

\*: 5V tolerant I/O



- List of pin functions

The number after the underscore ("\_") in pin names such as XXX\_1 and XXX\_2 indicates the relocated port number. For these pins, there are multiple pins that provide the same function for the same channel. Use the extended port function register (EPFR) to select the pin.

Pin function	Pin name	Function description	Pin No				
			LQFP-120	LQFP-100	BGA-112	LQFP-80	BGA-96
ADC	ADTG_0	A/D converter external trigger input pin	99	84	A7	66	A8
	ADTG_1		7	7	D3	7	D3
	ADTG_2		23	18	F4	13	G3
	ADTG_3		114	94	C5	74	C5
	ADTG_4		81	-	-	-	-
	ADTG_5		80	70	D11	-	-
	ADTG_6		17	12	E4	12	G2
	ADTG_7		35	30	J5	-	-
	ADTG_8		-	-	-	-	-
	AN00	A/D converter analog input pin. ANxx describes ADC ch.xx.	62	52	J11	42	J11
	AN01		63	53	J10	43	J10
	AN02		64	54	J8	44	J8
	AN03		65	55	H10	45	H10
	AN04		66	56	H9	46	H9
	AN05		67	57	H7	47	G10
	AN06		68	58	G10	48	G9
	AN07		69	59	G9	49	F10
	AN08		73	63	G8	53	F9
	AN09		74	64	F10	54	E11
	AN10		75	65	F9	55	E10
	AN11		76	66	E11	56	E9
	AN12		77	67	E10	-	-
	AN13		78	68	F8	-	-
	AN14		79	69	E9	-	-
	AN15		80	70	D11	-	-
	AN16		86	71	D10	57	D10
	AN17		87	72	E8	58	D9
	AN18		88	73	C11	59	C11
	AN19		89	74	C10	60	C10
	AN20		97	82	C8	-	-
AN21	98		83	D9	-	-	
AN22	99		84	A7	66	A8	
AN23	100		85	B7	-	-	

Pin function	Pin name	Function description	Pin No				
			LQFP-120	LQFP-100	BGA-112	LQFP-80	BGA-96
Base Timer 0	TIOA0_0	Base timer ch.0 TIOA pin	32	27	J4	-	-
	TIOA0_1		24	19	G3	14	H1
	TIOA0_2		100	85	B7	-	-
	TIOB0_0	Base timer ch.0 TIOB pin	45	40	J6	30	K6
	TIOB0_1		14	9	E1	9	E2
	TIOB0_2		101	86	C7	-	-
Base Timer 1	TIOA1_0	Base timer ch.1 TIOA pin	33	28	L5	-	-
	TIOA1_1		25	20	H1	15	H2
	TIOA1_2		5	5	D1	5	D1
	TIOB1_0	Base timer ch.1 TIOB pin	46	41	L7	31	J6
	TIOB1_1		15	10	E2	10	E3
	TIOB1_2		6	6	D2	6	D2
Base Timer 2	TIOA2_0	Base timer ch.2 TIOA pin	34	29	K5	-	-
	TIOA2_1		26	21	H2	16	H3
	TIOA2_2		116	96	C4	76	C4
	TIOB2_0	Base timer ch.2 TIOB pin	47	42	K7	32	L7
	TIOB2_1		16	11	E3	11	G1
	TIOB2_2		115	95	B4	75	B4
Base Timer 3	TIOA3_0	Base timer ch.3 TIOA pin	35	30	J5	-	-
	TIOA3_1		27	22	G4	17	J1
	TIOA3_2		105	90	C6	70	B6
	TIOB3_0	Base timer ch.3 TIOB pin	48	43	H6	33	K7
	TIOB3_1		17	12	E4	12	G2
	TIOB3_2		106	91	A5	71	C6
Base Timer 4	TIOA4_0	Base timer ch.4 TIOA pin	36	31	H5	21	L5
	TIOA4_1		28	23	H3	18	J2
	TIOA4_2		51	-	-	-	-
	TIOB4_0	Base timer ch.4 TIOB pin	49	44	J7	34	J7
	TIOB4_1		18	13	F1	-	-
	TIOB4_2		52	-	-	-	-
Base Timer 5	TIOA5_0	Base timer ch.5 TIOA pin	37	32	L6	22	K5
	TIOA5_1		29	24	J2	19	J4
	TIOA5_2		97	82	C8	-	-
	TIOB5_0	Base timer ch.5 TIOB pin	50	45	K8	35	K8
	TIOB5_1		19	14	F2	-	-
	TIOB5_2		98	83	D9	-	-
Base Timer 6	TIOA6_0	Base timer ch.6 TIOA pin	53	-	-	-	-
	TIOA6_1		104	89	B6	69	B7
	TIOA6_2		82	-	-	-	-
	TIOB6_0	Base timer ch.6 TIOB pin	54	-	-	-	-
	TIOB6_1		103	88	A6	68	C7
	TIOB6_2		81	-	-	-	-
Base Timer 7	TIOA7_0	Base timer ch.7 TIOA pin	112	-	-	-	-
	TIOA7_1		86	71	D10	57	D10
	TIOA7_2		109	-	-	-	-
	TIOB7_0	Base timer ch.7 TIOB pin	111	-	-	-	-
	TIOB7_1		87	72	E8	58	D9
	TIOB7_2		108	-	-	-	-

Pin function	Pin name	Function description	Pin No				
			LQFP-120	LQFP-100	BGA-112	LQFP-80	BGA-96
Base Timer 8	TIOA8_0	Base timer ch.8 TIOA pin	8	8	D5	8	E1
	TIOA8_1		73	63	G8	53	F9
	TIOA8_2		22	17	G2	-	-
	TIOB8_0	Base timer ch.8 TIOB pin	2	2	C1	2	C1
	TIOB8_1		63	53	J10	43	J10
	TIOB8_2		23	18	F4	-	-
Base Timer 9	TIOA9_0	Base timer ch.9 TIOA pin	9	-	-	-	-
	TIOA9_1		74	64	F10	54	E11
	TIOA9_2		79	69	E9	-	-
	TIOB9_0	Base timer ch.9 TIOB pin	3	3	C2	3	C2
	TIOB9_1		64	54	J8	44	J8
	TIOB9_2		80	70	D11	-	-
Base Timer 10	TIOA10_0	Base timer ch.10 TIOA pin	10	-	-	-	-
	TIOA10_1		75	65	F9	55	E10
	TIOA10_2		89	74	C10	60	C10
	TIOB10_0	Base timer ch.10 TIOB pin	4	4	B3	4	B3
	TIOB10_1		65	55	H10	45	H10
	TIOB10_2		88	73	C11	59	C11
Base Timer 11	TIOA11_0	Base timer ch.11 TIOA pin	11	-	-	-	-
	TIOA11_1		76	66	E11	56	E9
	TIOA11_2		83	-	-	-	-
	TIOB11_0	Base timer ch.11 TIOB pin	5	5	D1	5	D1
	TIOB11_1		66	56	H9	46	H9
	TIOB11_2		84	-	-	-	-
Base Timer 12	TIOA12_0	Base timer ch.12 TIOA pin	12	-	-	-	-
	TIOA12_1		77	67	E10	-	-
	TIOA12_2		110	-	-	-	-
	TIOB12_0	Base timer ch.12 TIOB pin	6	6	D2	6	D2
	TIOB12_1		67	57	H7	47	G10
	TIOB12_2		111	-	-	-	-
Base Timer 13	TIOA13_0	Base timer ch.13 TIOA pin	13	-	-	-	-
	TIOA13_1		78	68	F8	-	-
	TIOA13_2		14	9	E1	9	E2
	TIOB13_0	Base timer ch.13 TIOB pin	7	7	D3	7	D3
	TIOB13_1		68	58	G10	48	G9
	TIOB13_2		15	10	E2	10	E3
Base Timer 14	TIOA14_0	Base timer ch.14 TIOA pin	21	16	G1	-	-
	TIOA14_1		84	-	-	-	-
	TIOA14_2		92	77	A9	61	A10
	TIOB14_0	Base timer ch.14 TIOB pin	20	15	F3	-	-
	TIOB14_1		85	-	-	-	-
	TIOB14_2		94	79	B11	63	B11
Base Timer 15	TIOA15_0	Base timer ch.15 TIOA pin	119	99	A2	79	A2
	TIOA15_1		114	94	C5	74	C5
	TIOA15_2		18	13	F1	-	-
	TIOB15_0	Base timer ch.15 TIOB pin	118	98	A3	78	A3
	TIOB15_1		113	93	D6	73	B5
	TIOB15_2		19	14	F2	-	-

Pin function	Pin name	Function description	Pin No				
			LQFP-120	LQFP-100	BGA-112	LQFP-80	BGA-96
Debugger	SWCLK	Serial wire debug interface clock input pin	93	78	B9	62	B9
	SWDIO	Serial wire debug interface data input / output pin	95	80	A8	64	A9
	SWO	Serial wire viewer output pin	96	81	B8	65	B8
	TCK	J-TAG test clock input pin	93	78	B9	62	B9
	TDI	J-TAG test data input pin	94	79	B11	63	B11
	TDO	J-TAG debug data output pin	96	81	B8	65	B8
	TMS	J-TAG test mode state input/output pin	95	80	A8	64	A9
	TRACECLK	Trace CLK output pin of ETM	101	86	C7	-	-
	TRACED0	Trace data output pin of ETM	97	82	C8	-	-
	TRACED1		98	83	D9	-	-
	TRACED2		99	84	A7	-	-
	TRACED3		100	85	B7	-	-
	TRSTX	J-TAG test reset input pin	92	77	A9	61	A10
	External Bus	MAD00_0	External bus interface address bus	36	31	H5	21
MAD01_0		37		32	L6	22	K5
MAD02_0		44		39	K6	29	J5
MAD03_0		45		40	J6	30	K6
MAD04_0		46		41	L7	31	J6
MAD05_0		47		42	K7	32	L7
MAD06_0		48		43	H6	33	K7
MAD07_0		49		44	J7	34	J7
MAD08_0		50		45	K8	35	K8
MAD09_0		63		53	J10	43	J10
MAD10_0		64		54	J8	44	J8
MAD11_0		65		55	H10	45	H10
MAD12_0		66		56	H9	46	H9
MAD13_0		67		57	H7	47	G10
MAD14_0		68		58	G10	48	G9
MAD15_0		69		59	G9	49	F10
MAD16_0		73		63	G8	53	F9
MAD17_0		74		64	F10	54	E11
MAD18_0		75		65	F9	55	E10
MAD19_0		76		66	E11	56	E9
MAD20_0		77		67	E10	-	-
MAD21_0		78		68	F8	-	-
MAD22_0		79		69	E9	-	-
MAD23_0		80		70	D11	-	-
MAD24_0		89		74	C10	60	C10

Pin function	Pin name	Function description	Pin No				
			LQFP-120	LQFP-100	BGA-112	LQFP-80	BGA-96
External Bus	MCSX0_0	External bus interface chip select output pin	103	88	A6	68	C7
	MCSX1_0		102	87	D7	67	C8
	MCSX2_0		101	86	C7	-	-
	MCSX3_0		100	85	B7	-	-
	MCSX4_0		98	83	D9	-	-
	MCSX5_0		97	82	C8	-	-
	MCSX6_0		94	79	B11	63	B11
	MCSX7_0		92	77	A9	61	A10
	MDQM0_0	External bus interface byte mask signal output pin	105	90	C6	70	B6
	MDQM1_0		106	91	A5	71	C6
	MOEX_0	External bus interface read enable signal for SRAM	114	94	C5	74	C5
	MWEX_0	External bus interface write enable signal for SRAM	113	93	D6	73	B5
	MNALE_0	External bus interface ALE signal to control NAND Flash memory output pin	18	-	-	-	-
	MNCLE_0	External bus interface CLE signal to control NAND Flash memory output pin	19	-	-	-	-
	MNREX_0	External bus interface read enable signal to control NAND Flash memory	21	-	-	-	-
	MNWEX_0	External bus interface write enable signal to control NAND Flash memory	20	-	-	-	-
	MADATA00_0	External bus interface data bus	2	2	C1	2	C1
	MADATA01_0		3	3	C2	3	C2
	MADATA02_0		4	4	B3	4	B3
	MADATA03_0		5	5	D1	5	D1
	MADATA04_0		6	6	D2	6	D2
	MADATA05_0		7	7	D3	7	D3
	MADATA06_0		8	8	D5	8	E1
MADATA07_0	9		9	E1	9	E2	
MADATA08_0	10		10	E2	10	E3	
MADATA09_0	11		11	E3	11	G1	
MADATA10_0	12		12	E4	12	G2	
MADATA11_0	13		13	F1	-	-	
MADATA12_0	14		14	F2	-	-	
MADATA13_0	15		15	F3	-	-	
MADATA14_0	16		16	G1	-	-	
MADATA15_0	17	17	G2	-	-		
MALE_0	Latch enable signal for multiplex	104	89	B6	69	B7	
MRDY_0	External RDY input signal	116	96	C4	76	C4	
MCLKOUT_0	External bus clock output pin	99	84	A7	66	A8	

Pin function	Pin name	Function description	Pin No				
			LQFP-120	LQFP-100	BGA-112	LQFP-80	BGA-96
External Interrupt	INT00_0	External interrupt request 00 input pin	2	2	C1	2	C1
	INT00_1		97	82	C8	-	-
	INT00_2		102	87	D7	67	C8
	INT01_0	External interrupt request 01 input pin	3	3	C2	3	C2
	INT01_1		98	83	D9	-	-
	INT01_2		85	-	-	-	-
	INT02_0	External interrupt request 02 input pin	4	4	B3	4	B3
	INT02_1		63	53	J10	43	J10
	INT02_2		82	-	-	-	-
	INT03_0	External interrupt request 03 input pin	113	93	D6	73	B5
	INT03_1		66	56	H9	46	H9
	INT03_2		14	9	E1	9	E2
	INT04_0	External interrupt request 04 input pin	17	12	E4	12	G2
	INT04_1		69	59	G9	49	F10
	INT04_2		15	10	E2	10	E3
	INT05_0	External interrupt request 05 input pin	89	74	C10	60	C10
	INT05_1		75	65	F9	55	E10
	INT05_2		16	11	E3	11	G1
	INT06_0	External interrupt request 06 input pin	23	18	F4	13	G3
	INT06_1		88	73	C11	59	C11
	INT06_2		50	45	K8	35	K8
	INT07_0	External interrupt request 07 input pin	24	19	G3	14	H1
	INT07_1		114	94	C5	74	C5
	INT07_2		5	5	D1	5	D1
	INT08_0	External interrupt request 08 input pin	34	29	K5	-	-
	INT08_1		19	14	F2	-	-
	INT08_2		8	8	D5	8	E1
	INT09_0	External interrupt request 09 input pin	35	30	J5	-	-
	INT09_1		20	15	F3	-	-
	INT09_2		11	-	-	-	-
	INT10_0	External interrupt request 10 input pin	36	31	H5	21	L5
	INT10_1		21	16	G1	-	-
	INT10_2		112	-	-	-	-
	INT11_0	External interrupt request 11 input pin	37	32	L6	22	K5
	INT11_1		22	17	G2	-	-
	INT11_2		110	-	-	-	-
	INT12_0	External interrupt request 12 input pin	48	43	H6	33	K7
	INT12_1		32	27	J4	-	-
	INT12_2		108	-	-	-	-
	INT13_0	External interrupt request 13 input pin	49	44	J7	34	J7
	INT13_1		33	28	L5	-	-
	INT13_2		52	-	-	-	-
	INT14_0	External interrupt request 14 input pin	67	57	H7	47	G10
	INT14_1		44	39	K6	29	J5
INT14_2	53		-	-	-	-	

Pin function	Pin name	Function description	Pin No				
			LQFP-120	LQFP-100	BGA-112	LQFP-80	BGA-96
External Interrupt	INT15_0	External interrupt request 15 input pin	68	58	G10	48	G9
	INT15_1		116	96	C4	76	C4
	INT15_2		54	-	-	-	-
	INT16_0	External interrupt request 16 input pin	100	85	B7	-	-
	INT16_1		118	98	A3	78	A3
	INT16_2		12	-	-	-	-
	INT17_0	External interrupt request 17 input pin	101	86	C7	-	-
	INT17_1		119	99	A2	79	A2
	INT17_2		13	-	-	-	-
	INT18_0	External interrupt request 18 input pin	103	88	A6	68	C7
	INT18_1		6	6	D2	6	D2
	INT18_2		26	21	H2	16	H3
	INT19_0	External interrupt request 19 input pin	104	89	B6	69	B7
	INT19_1		7	7	D3	7	D3
	INT19_2		28	23	H3	18	J2
	INT20_0	External interrupt request 20 input pin	105	90	C6	70	B6
	INT20_1		45	40	J6	30	K6
	INT20_2		76	66	E11	56	E9
	INT21_0	External interrupt request 21 input pin	106	91	A5	71	C6
	INT21_1		46	41	L7	31	J6
	INT21_2		77	67	E10	-	-
	INT22_0	External interrupt request 22 input pin	109	-	-	-	-
	INT22_1		47	42	K7	32	L7
INT22_2	78		68	F8	-	-	
INT23_0	External interrupt request 23 input pin	111	-	-	-	-	
INT23_1		99	84	A7	66	A8	
INT23_2		79	69	E9	-	-	
NMIX	Non-Maskable Interrupt input pin	107	92	B5	72	A6	

Pin function	Pin name	Function description	Pin No				
			LQFP-120	LQFP-100	BGA-112	LQFP-80	BGA-96
GPIO	P00	General-purpose I/O port 0	92	77	A9	61	A10
	P01		93	78	B9	62	B9
	P02		94	79	B11	63	B11
	P03		95	80	A8	64	A9
	P04		96	81	B8	65	B8
	P05		97	82	C8	-	-
	P06		98	83	D9	-	-
	P07		99	84	A7	66	A8
	P08		100	85	B7	-	-
	P09		101	86	C7	-	-
	P0A		102	87	D7	67	C8
	P0B		103	88	A6	68	C7
	P0C		104	89	B6	69	B7
	P0D		105	90	C6	70	B6
	P0E		106	91	A5	71	C6
	P0F		107	92	B5	72	A6
	P10	General-purpose I/O port 1	62	52	J11	42	J11
	P11		63	53	J10	43	J10
	P12		64	54	J8	44	J8
	P13		65	55	H10	45	H10
	P14		66	56	H9	46	H9
	P15		67	57	H7	47	G10
	P16		68	58	G10	48	G9
	P17		69	59	G9	49	F10
	P18		73	63	G8	53	F9
	P19		74	64	F10	54	E11
	P1A		75	65	F9	55	E10
	P1B		76	66	E11	56	E9
P1C	77	67	E10	-	-		
P1D	78	68	F8	-	-		
P1E	79	69	E9	-	-		
P1F	80	70	D11	-	-		
P20	General-purpose I/O port 2	89	74	C10	60	C10	
P21		88	73	C11	59	C11	
P22		87	72	E8	58	D9	
P23		86	71	D10	57	D10	
P24		85	-	-	-	-	
P25		84	-	-	-	-	
P26		83	-	-	-	-	
P27		82	-	-	-	-	
P28	81	-	-	-	-		



Pin function	Pin name	Function description	Pin No				
			LQFP-120	LQFP-100	BGA-112	LQFP-80	BGA-96
GPIO	P30	General-purpose I/O port 3	14	9	E1	9	E2
	P31		15	10	E2	10	E3
	P32		16	11	E3	11	G1
	P33		17	12	E4	12	G2
	P34		18	13	F1	-	-
	P35		19	14	F2	-	-
	P36		20	15	F3	-	-
	P37		21	16	G1	-	-
	P38		22	17	G2	-	-
	P39		23	18	F4	13	G3
	P3A		24	19	G3	14	H1
	P3B		25	20	H1	15	H2
	P3C		26	21	H2	16	H3
	P3D		27	22	G4	17	J1
	P3E		28	23	H3	18	J2
	P3F		29	24	J2	19	J4
	P40	32	General-purpose I/O port 4	27	J4	-	-
	P41	33		28	L5	-	-
	P42	34		29	K5	-	-
	P43	35		30	J5	-	-
	P44	36		31	H5	21	L5
	P45	37		32	L6	22	K5
	P46	41		36	L3	26	L3
	P47	42		37	K3	27	K3
	P48	44		39	K6	29	J5
	P49	45		40	J6	30	K6
	P4A	46		41	L7	31	J6
	P4B	47		42	K7	32	L7
	P4C	48		43	H6	33	K7
	P4D	49		44	J7	34	J7
	P4E	50		45	K8	35	K8
	P50	2		General-purpose I/O port 5	2	C1	2
	P51	3	3		C2	3	C2
	P52	4	4		B3	4	B3
	P53	5	5		D1	5	D1
	P54	6	6		D2	6	D2
	P55	7	7		D3	7	D3
	P56	8	8		D5	8	E1
	P57	9	-		-	-	-
	P58	10	-		-	-	-
	P59	11	-		-	-	-
	P5A	12	-	-	-	-	
	P5B	13	-	-	-	-	
	P60	116	General-purpose I/O port 6	96	C4	76	C4
	P61	115		95	B4	75	B4
	P62	114		94	C5	74	C5
	P63	113		93	D6	73	B5
	P64	112		-	-	-	-
	P65	111		-	-	-	-
	P66	110		-	-	-	-
	P67	109		-	-	-	-
	P68	108	-	-	-	-	

Pin function	Pin name	Function description	Pin No				
			LQFP-120	LQFP-100	BGA-112	LQFP-80	BGA-96
GPIO	P70	General-purpose I/O port 7	51	-	-	-	-
	P71		52	-	-	-	-
	P72		53	-	-	-	-
	P73		54	-	-	-	-
	P74		55	-	-	-	-
	P80	General-purpose I/O port 8	118	98	A3	78	A3
	P81		119	99	A2	79	A2
	PE0	General-purpose I/O port E	56	46	K9	36	K9
	PE2		58	48	L9	38	L9
	PE3		59	49	L10	39	L10

Pin function	Pin name	Function description	Pin No				
			LQFP-120	LQFP-100	BGA-112	LQFP-80	BGA-96
Multi-function Serial 0	SIN0_0	Multi-function serial interface ch.0 input pin	88	73	C11	59	C11
	SIN0_1		66	56	H9	46	H9
	SOT0_0 (SDA0_0)	Multi-function serial interface ch.0 output pin. This pin operates as SOT0 when it is used in a UART/CSIO (operation modes 0 to 2) and as SDA0 when it is used in an I <sup>2</sup> C (operation mode 4).	87	72	E8	58	D9
	SOT0_1 (SDA0_1)		67	57	H7	47	G10
	SCK0_0 (SCL0_0)	Multi-function serial interface ch.0 clock I/O pin. This pin operates as SCK0 when it is used in a UART/CSIO (operation modes 0 to 2) and as SCL0 when it is used in an I <sup>2</sup> C (operation mode 4).	86	71	D10	57	D10
	SCK0_1 (SCL0_1)		68	58	G10	48	G9
Multi-function Serial 1	SIN1_0	Multi-function serial interface ch.1 input pin	8	-	-	-	-
	SIN1_1		63	53	J10	43	J10
	SOT1_0 (SDA1_0)	Multi-function serial interface ch.1 output pin. This pin operates as SOT1 when it is used in a UART/CSIO (operation modes 0 to 2) and as SDA1 when it is used in an I <sup>2</sup> C (operation mode 4).	9	-	-	-	-
	SOT1_1 (SDA1_1)		64	54	J8	44	J8
	SCK1_0 (SCL1_0)	Multi-function serial interface ch.1 clock I/O pin. This pin operates as SCK1 when it is used in a UART/CSIO (operation modes 0 to 2) and as SCL1 when it is used in an I <sup>2</sup> C (operation mode 4).	10	-	-	-	-
	SCK1_1 (SCL1_1)		65	55	H10	45	H10

Pin function	Pin name	Function description	Pin No				
			LQFP-120	LQFP-100	BGA-112	LQFP-80	BGA-96
Multi-function Serial 2	SIN2_0	Multi-function serial interface ch.2 input pin	53	-	-	-	-
	SIN2_1		85	-	-	-	-
	SIN2_2		69	59	G9	49	F10
	SOT2_0 (SDA2_0)	Multi-function serial interface ch.2 output pin.	54	-	-	-	-
	SOT2_1 (SDA2_1)	This pin operates as SOT2 when it is used in a UART/CSIO (operation modes 0 to 2) and as SDA2 when it is used in an I <sup>2</sup> C (operation mode 4).	84	-	-	-	-
	SOT2_2 (SDA2_2)		73	63	G8	53	F9
	SCK2_0 (SCL2_0)	Multi-function serial interface ch.2 clock I/O pin.	55	-	-	-	-
	SCK2_1 (SCL2_1)	This pin operates as SCK2 when it is used in a UART/CSIO (operation modes 0 to 2) and as SCL2 when it is used in an I <sup>2</sup> C (operation mode 4).	83	-	-	-	-
	SCK2_2 (SCL2_2)		74	64	F10	54	E11
Multi-function Serial 3	SIN3_0	Multi-function serial interface ch.3 input pin	110	-	-	-	-
	SIN3_1		2	2	C1	2	C1
	SIN3_2		44	39	K6	29	J5
	SOT3_0 (SDA3_0)	Multi-function serial interface ch.3 output pin.	109	-	-	-	-
	SOT3_1 (SDA3_1)	This pin operates as SOT3 when it is used in a UART/CSIO (operation modes 0 to 2) and as SDA3 when it is used in an I <sup>2</sup> C (operation mode 4).	3	3	C2	3	C2
	SOT3_2 (SDA3_2)		45	40	J6	30	K6
	SCK3_0 (SCL3_0)	Multi-function serial interface ch.3 clock I/O pin.	108	-	-	-	-
	SCK3_1 (SCL3_1)	This pin operates as SCK3 when it is used in a UART/CSIO (operation modes 0 to 2) and as SCL3 when it is used in an I <sup>2</sup> C (operation mode 4).	4	4	B3	4	B3
	SCK3_2 (SCL3_2)		46	41	L7	31	J6

Pin function	Pin name	Function description	Pin No				
			LQFP-120	LQFP-100	BGA-112	LQFP-80	BGA-96
Multi-function Serial 4	SIN4_0	Multi-function serial interface ch.4 input pin	102	87	D7	67	C8
	SIN4_1		75	65	F9	55	E10
	SIN4_2		97	82	C8	-	-
	SOT4_0 (SDA4_0)	Multi-function serial interface ch.4 output pin.	103	88	A6	68	C7
	SOT4_1 (SDA4_1)	This pin operates as SOT4 when it is used in a UART/CSIO (operation modes 0 to 2) and as SDA4 when it is used in an I <sup>2</sup> C (operation mode 4).	76	66	E11	56	E9
	SOT4_2 (SDA4_2)		98	83	D9	-	-
	SCK4_0 (SCL4_0)	Multi-function serial interface ch.4 clock I/O pin.	104	89	B6	69	B7
	SCK4_1 (SCL4_1)	This pin operates as SCK4 when it is used in a UART/CSIO (operation modes 0 to 2) and as SCL4 when it is used in an I <sup>2</sup> C (operation mode 4).	77	67	E10	-	-
	SCK4_2 (SCL4_2)		99	84	A7	-	-
	RTS4_0	Multi-function serial interface ch.4 RTS output pin	105	90	C6	70	B6
	RTS4_1		79	69	E9	-	-
	RTS4_2		101	86	C7	-	-
	CTS4_0	Multi-function serial interface ch.4 CTS input pin	106	91	A5	71	C6
	CTS4_1		78	68	F8	-	-
	CTS4_2		100	85	B7	-	-

Pin function	Pin name	Function description	Pin No				
			LQFP-120	LQFP-100	BGA-112	LQFP-80	BGA-96
Multi-function Serial 5	SIN5_0	Multi-function serial interface ch.5 input pin	116	96	C4	76	C4
	SIN5_1		113	-	-	-	-
	SIN5_2		20	15	F3	-	-
	SOT5_0 (SDA5_0)	Multi-function serial interface ch.5 output pin.	115	95	B4	75	B4
	SOT5_1 (SDA5_1)	This pin operates as SOT5 when it is used in a UART/CSIO (operation modes 0 to 2) and as SDA5 when it is used in an I <sup>2</sup> C (operation mode 4).	112	-	-	-	-
	SOT5_2 (SDA5_2)		21	16	G1	-	-
	SCK5_0 (SCL5_0)	Multi-function serial interface ch.5 clock I/O pin.	114	94	C5	74	C5
	SCK5_1 (SCL5_1)	This pin operates as SCK5 when it is used in a UART/CSIO (operation modes 0 to 2) and as SCL5 when it is used in an I <sup>2</sup> C (operation mode 4).	111	-	-	-	-
	SCK5_2 (SCL5_2)		22	17	G2	-	-

Pin function	Pin name	Function description	Pin No				
			LQFP-120	LQFP-100	BGA-112	LQFP-80	BGA-96
Multi-function Serial 6	SIN6_0	Multi-function serial interface ch.6 input pin	5	5	D1	5	D1
	SIN6_1		17	12	E4	12	G2
	SOT6_0 (SDA6_0)	Multi-function serial interface ch.6 output pin. This pin operates as SOT6 when it is used in a UART/CSIO	6	6	D2	6	D2
	SOT6_1 (SDA6_1)	(operation modes 0 to 2) and as SDA6 when it is used in an I <sup>2</sup> C (operation mode 4).	16	11	E3	11	G1
	SCK6_0 (SCL6_0)	Multi-function serial interface ch.6 clock I/O pin. This pin operates as SCK6 when it is used in a UART/CSIO	7	7	D3	7	D3
SCK6_1 (SCL6_1)	(operation modes 0 to 2) and as SCL6 when it is used in an I <sup>2</sup> C (operation mode 4).	15	10	E2	10	E3	
Multi-function Serial 7	SIN7_0	Multi-function serial interface ch.7 input pin	11	-	-	-	-
	SIN7_1		50	45	K8	35	K8
	SOT7_0 (SDA7_0)	Multi-function serial interface ch.7 output pin. This pin operates as SOT7 when it is used in a UART/CSIO	12	-	-	-	-
	SOT7_1 (SDA7_1)	(operation modes 0 to 2) and as SDA7 when it is used in an I <sup>2</sup> C (operation mode 4).	49	44	J7	34	J7
	SCK7_0 (SCL7_0)	Multi-function serial interface ch.7 clock I/O pin. This pin operates as SCK7 when it is used in a UART/CSIO	13	-	-	-	-
SCK7_1 (SCL7_1)	(operation modes 0 to 2) and as SCL7 when it is used in an I <sup>2</sup> C (operation mode 4).	48	43	H6	33	K7	

Pin function	Pin name	Function description	Pin No				
			LQFP-120	LQFP-100	BGA-112	LQFP-80	BGA-96
Multi-function Serial 8	SIN8_0	Multi-function serial interface ch.8 input pin	97	82	C8	-	-
	SOT8_0 (SDA8_0)	Multi-function serial interface ch.8 output pin. This pin operates as SOT8 when it is used in a UART/CSIO (operation modes 0 to 2) and as SDA8 when it is used in an I <sup>2</sup> C (operation mode 4).	94	79	B11	-	-
	SCK8_0 (SCL8_0)	Multi-function serial interface ch.8 clock I/O pin. This pin operates as SCK8 when it is used in a UART/CSIO (operation modes 0 to 2) and as SCL8 when it is used in an I <sup>2</sup> C (operation mode 4).	92	77	A9	-	-
Multi-function Serial 9	SIN9_0	Multi-function serial interface ch.9 input pin	17	12	E4	-	-
	SOT9_0 (SDA9_0)	Multi-function serial interface ch.9 output pin. This pin operates as SOT9 when it is used in a UART/CSIO (operation modes 0 to 2) and as SDA9 when it is used in an I <sup>2</sup> C (operation mode 4).	18	13	F1	-	-
	SCK9_0 (SCL9_0)	Multi-function serial interface ch.9 clock I/O pin. This pin operates as SCK9 when it is used in a UART/CSIO (operation modes 0 to 2) and as SCL9 when it is used in an I <sup>2</sup> C (operation mode 4).	19	14	F2	-	-
Multi-function Serial 10	SIN10_0	Multi-function serial interface ch.10 input pin	23	18	F4	13	G3
	SOT10_0 (SDA10_0)	Multi-function serial interface ch.10 output pin. This pin operates as SOT10 when it is used in a UART/CSIO (operation modes 0 to 2) and as SDA10 when it is used in an I <sup>2</sup> C (operation mode 4).	24	19	G3	14	H1
	SCK10_0 (SCL10_0)	Multi-function serial interface ch.10 clock I/O pin. This pin operates as SCK10 when it is used in a UART/CSIO (operation modes 0 to 2) and as SCL10 when it is used in an I <sup>2</sup> C (operation mode 4).	25	20	H1	15	H2



Pin function	Pin name	Function description	Pin No				
			LQFP-120	LQFP-100	BGA-112	LQFP-80	BGA-96
Multi-function Serial 11	SIN11_0	Multi-function serial interface ch.11 input pin	26	21	H2	16	H3
	SOT11_0 (SDA11_0)	Multi-function serial interface ch.11 output pin. This pin operates as SOT11 when it is used in a UART/CSIO (operation modes 0 to 2) and as SDA11 when it is used in an I <sup>2</sup> C (operation mode 4).	27	22	G4	17	J1
	SCK11_0 (SCL11_0)	Multi-function serial interface ch.11 clock I/O pin. This pin operates as SCK11 when it is used in a UART/CSIO (operation modes 0 to 2) and as SCL11 when it is used in an I <sup>2</sup> C (operation mode 4).	28	23	H3	18	J2
Multi-function Serial 12	SIN12_0	Multi-function serial interface ch.12 input pin	32	27	J4	-	-
	SOT12_0 (SDA12_0)	Multi-function serial interface ch.12 output pin. This pin operates as SOT12 when it is used in a UART/CSIO (operation modes 0 to 2) and as SDA12 when it is used in an I <sup>2</sup> C (operation mode 4).	33	28	L5	-	-
	SCK12_0 (SCL12_0)	Multi-function serial interface ch.12 clock I/O pin. This pin operates as SCK12 when it is used in a UART/CSIO (operation modes 0 to 2) and as SCL12 when it is used in an I <sup>2</sup> C (operation mode 4).	34	29	K5	-	-
Multi-function Serial 13	SIN13_0	Multi-function serial interface ch.13 input pin	35	30	J5	-	-
	SOT13_0 (SDA13_0)	Multi-function serial interface ch.13 output pin. This pin operates as SOT13 when it is used in a UART/CSIO (operation modes 0 to 2) and as SDA13 when it is used in an I <sup>2</sup> C (operation mode 4).	36	31	H5	-	-
	SCK13_0 (SCL13_0)	Multi-function serial interface ch.13 clock I/O pin. This pin operates as SCK13 when it is used in a UART/CSIO (operation modes 0 to 2) and as SCL13 when it is used in an I <sup>2</sup> C (operation mode 4).	37	32	L6	-	-

Pin function	Pin name	Function description	Pin No				
			LQFP-120	LQFP-100	BGA-112	LQFP-80	BGA-96
Multi-function Serial 14	SIN14_0	Multi-function serial interface ch.14 input pin	50	-	-	-	-
	SOT14_0 (SDA14_0)	Multi-function serial interface ch.14 output pin. This pin operates as SOT14 when it is used in a UART/CSIO (operation modes 0 to 2) and as SDA14 when it is used in an I <sup>2</sup> C (operation mode 4).	51	-	-	-	-
	SCK14_0 (SCL14_0)	Multi-function serial interface ch.14 clock I/O pin. This pin operates as SCK14 when it is used in a UART/CSIO (operation modes 0 to 2) and as SCL14 when it is used in an I <sup>2</sup> C (operation mode 4).	52	-	-	-	-
Multi-function Serial 15	SIN15_0	Multi-function serial interface ch.15 input pin	82	-	-	-	-
	SOT15_0 (SDA15_0)	Multi-function serial interface ch.15 output pin. This pin operates as SOT15 when it is used in a UART/CSIO (operation modes 0 to 2) and as SDA15 when it is used in an I <sup>2</sup> C (operation mode 4).	81	-	-	-	-
	SCK15_0 (SCL15_0)	Multi-function serial interface ch.15 clock I/O pin. This pin operates as SCK15 when it is used in a UART/CSIO (operation modes 0 to 2) and as SCL15 when it is used in an I <sup>2</sup> C (operation mode 4).	80	-	-	-	-

Pin function	Pin name	Function description	Pin No					
			LQFP-120	LQFP-100	BGA-112	LQFP-80	BGA-96	
Multi-function Timer 0	DTTI0X_0	Input signal of waveform generator to control outputs RTO00 to RTO05 of multi-function timer 0.	23	18	F4	13	G3	
	DTTI0X_1		79	69	E9	-	-	
	FRCK0_0	16-bit free-run timer ch.0 external clock input pin	18	13	F1	-	-	
	FRCK0_1		80	70	D11	-	-	
	FRCK0_2		63	53	J10	43	J10	
	IC00_0	16-bit input capture input pin of multi-function timer 0. ICxx describes channel number.	22	17	G2	-	-	
	IC00_1		75	65	F9	55	E10	
	IC00_2		64	54	J8	44	J8	
	IC01_0		21	16	G1	-	-	
	IC01_1		76	66	E11	56	E9	
	IC01_2		65	55	H10	45	H10	
	IC02_0		20	15	F3	-	-	
	IC02_1		77	67	E10	-	-	
	IC02_2		66	56	H9	46	H9	
	IC03_0		19	14	F2	-	-	
	IC03_1		78	68	F8	-	-	
	IC03_2		67	57	H7	47	G10	
	RTO00_0 (PPG00_0)		Waveform generator output pin of multi-function timer 0.	24	19	G3	14	H1
	RTO00_1 (PPG00_1)		This pin operates as PPG00 when it is used in PPG0 output mode.	86	71	D10	57	D10
	RTO01_0 (PPG00_0)		Waveform generator output pin of multi-function timer 0.	25	20	H1	15	H2
	RTO01_1 (PPG00_1)	This pin operates as PPG00 when it is used in PPG0 output mode.	85	-	-	-	-	
	RTO02_0 (PPG02_0)	Waveform generator output pin of multi-function timer 0.	26	21	H2	16	H3	
	RTO02_1 (PPG02_1)	This pin operates as PPG02 when it is used in PPG0 output mode.	84	-	-	-	-	
	RTO03_0 (PPG02_0)	Waveform generator output pin of multi-function timer 0.	27	22	G4	17	J1	
	RTO03_1 (PPG02_1)	This pin operates as PPG02 when it is used in PPG0 output mode.	83	-	-	-	-	
	RTO04_0 (PPG04_0)	Waveform generator output pin of multi-function timer 0.	28	23	H3	18	J2	
	RTO04_1 (PPG04_1)	This pin operates as PPG04 when it is used in PPG0 output mode.	82	-	-	-	-	
	RTO05_0 (PPG04_0)	Waveform generator output pin of multi-function timer 0.	29	24	J2	19	J4	
	RTO05_1 (PPG04_1)	This pin operates as PPG04 when it is used in PPG0 output mode.	81	-	-	-	-	
	IGTRG_0	PPG IGMT mode external trigger input pin	46	41	L7	31	J6	
IGTRG_1	116		96	C4	76	C4		

Pin function	Pin name	Function description	Pin No				
			LQFP-120	LQFP-100	BGA-112	LQFP-80	BGA-96
Quadrature Position/ Revolution Counter 0	AIN0_0	QPRC ch.0 AIN input pin	14	9	E1	9	E2
	AIN0_1		45	40	J6	30	K6
	AIN0_2		2	2	C1	2	C1
	BIN0_0	QPRC ch.0 BIN input pin	15	10	E2	10	E3
	BIN0_1		46	41	L7	31	J6
	BIN0_2		3	3	C2	3	C2
	ZIN0_0	QPRC ch.0 ZIN input pin	16	11	E3	11	G1
	ZIN0_1		47	42	K7	32	L7
ZIN0_2	4		4	B3	4	B3	
Quadrature Position/ Revolution Counter 1	AIN1_1	QPRC ch.1 AIN input pin	89	74	C10	60	C10
	AIN1_2		48	43	H6	33	K7
	BIN1_1	QPRC ch.1 BIN input pin	88	73	C11	59	C11
	BIN1_2		49	44	J7	34	J7
	ZIN1_1	QPRC ch.1 ZIN input pin	87	72	E8	58	D9
	ZIN1_2		50	45	K8	35	K8
Real-time clock	RTCCO_0	0.5 seconds pulse output pin of Real-time clock	107	92	B5	72	A6
	RTCCO_1		65	55	H10	45	H10
	RTCCO_2		24	19	G3	14	H1
	SUBOUT_0	Sub clock output pin	107	92	B5	72	A6
	SUBOUT_1		65	55	H10	45	H10
	SUBOUT_2		24	19	G3	14	H1
Low-Power Consumption Mode	WKUP0	Deep standby mode return signal input pin 0	107	92	B5	72	A6
	WKUP1	Deep standby mode return signal input pin 1	63	53	J10	43	J10
	WKUP2	Deep standby mode return signal input pin 2	88	73	C11	59	C11
	WKUP3	Deep standby mode return signal input pin 3	116	96	C4	76	C4
	WKUP4	Deep standby mode return signal input pin 4	14	9	E1	9	E2
	WKUP5	Deep standby mode return signal input pin 5	102	87	D7	67	C8
HDMI-CEC/ Remote Control Reception	CEC0_0	HDMI-CEC/Remote Control Reception ch.0 input/output pin	48	43	H6	33	K7
	CEC0_1		103	88	A6	68	C7
	CEC1_0	HDMI-CEC/Remote Control Reception ch.1 input/output pin	116	96	C4	76	C4
	CEC1_1		8	8	D5	8	E1

Pin function	Pin name	Function description	Pin No				
			LQFP-120	LQFP-100	BGA-112	LQFP-80	BGA-96
RESET	INITX	External Reset Input pin. A reset is valid when INITX="L".	43	38	K4	28	K4
Mode	MD0	Mode 0 pin. During normal operation, MD0="L" must be input. During serial programming to Flash memory, MD0="H" must be input.	57	47	L8	37	L8
	MD1	Mode 1 pin. During serial programming to Flash memory, MD1="L" must be input.	56	46	K9	36	K9
POWER	VCC	Power supply Pin	1	1	B1	1	B1
	VCC	Power supply Pin	31	26	J1	-	-
	VCC	Power supply Pin	40	35	K1	25	K1
	VCC	Power supply Pin	61	51	K11	41	K11
	VCC	Power supply Pin	91	76	A10	-	-
	VCC	Power supply Pin	117	97	A4	77	A4
GND	VSS	GND Pin	-	-	-	-	F1
	VSS	GND Pin	-	-	-	-	F2
	VSS	GND Pin	-	-	-	-	F3
	VSS	GND Pin	-	-	B2	-	B2
	VSS	GND Pin	30	25	L1	20	L1
	VSS	GND Pin	-	-	K2	-	K2
	VSS	GND Pin	-	-	J3	-	J3
	VSS	GND Pin	-	-	H4	-	-
	VSS	GND Pin	-	-	-	-	L6
	VSS	GND Pin	39	34	L4	24	L4
	VSS	GND Pin	60	50	L11	40	L11
	VSS	GND Pin	-	-	K10	-	K10
	VSS	GND Pin	-	-	J9	-	J9
	VSS	GND Pin	-	-	H8	-	-
	VSS	GND Pin	-	-	B10	-	B10
	VSS	GND Pin	-	-	C9	-	C9
	VSS	GND Pin	-	-	-	-	D11
	VSS	GND Pin	90	75	A11	-	A11
	VSS	GND Pin	-	-	D8	-	-
	VSS	GND Pin	-	-	-	-	A7
	VSS	GND Pin	-	-	D4	-	-
	VSS	GND Pin	-	-	C3	-	C3
	VSS	GND Pin	-	-	-	-	A5
VSS	GND Pin	120	100	A1	80	A1	

Pin function	Pin name	Function description	Pin No				
			LQFP-120	LQFP-100	BGA-112	LQFP-80	BGA-96
CLOCK	X0	Main clock (oscillation) input pin	58	48	L9	38	L9
	X0A	Sub clock (oscillation) input pin	41	36	L3	26	L3
	X1	Main clock (oscillation) I/O pin	59	49	L10	39	L10
	X1A	Sub clock (oscillation) I/O pin	42	37	K3	27	K3
	CROUT_0	Built-in high-speed CR-osc clock output port	89	74	C10	60	C10
CROUT_1	107		92	B5	72	A6	
ADC POWER	AVCC	A/D converter analog power supply pin	70	60	H11	50	H11
	AVRH	A/D converter analog reference voltage input pin	71	61	F11	51	F11
ADC GND	AVSS	A/D converter GND pin	72	62	G11	52	G11
C pin	C	Power stabilization capacity pin	38	33	L2	23	L2

■ I/O CIRCUIT TYPE

Type	Circuit	Remarks
A		<p>It is possible to select the main oscillation / GPIO function</p> <p>When the main oscillation is selected.</p> <ul style="list-style-type: none"> <li>• Oscillation feedback resistor : Approximately 1MΩ</li> <li>• With standby mode control</li> </ul> <p>When the GPIO is selected.</p> <ul style="list-style-type: none"> <li>• CMOS level output.</li> <li>• CMOS level hysteresis input</li> <li>• With pull-up resistor control</li> <li>• With standby mode control</li> <li>• Pull-up resistor : Approximately 33kΩ</li> <li>• <math>I_{OH} = -4mA, I_{OL} = 4mA</math></li> </ul>
B		<ul style="list-style-type: none"> <li>• CMOS level hysteresis input</li> <li>• Pull-up resistor : Approximately 33kΩ</li> </ul>

Type	Circuit	Remarks
C		<ul style="list-style-type: none"> <li>• Open drain output</li> <li>• CMOS level hysteresis input</li> </ul>
D		<p>It is possible to select the sub oscillation / GPIO function</p> <p>When the sub oscillation is selected.</p> <ul style="list-style-type: none"> <li>• Oscillation feedback resistor : Approximately 5MΩ</li> <li>• With standby mode control</li> </ul> <p>When the GPIO is selected.</p> <ul style="list-style-type: none"> <li>• CMOS level output.</li> <li>• CMOS level hysteresis input</li> <li>• With pull-up resistor control</li> <li>• With standby mode control</li> <li>• Pull-up resistor : Approximately 33kΩ</li> <li>• <math>I_{OH} = -4mA</math>, <math>I_{OL} = 4mA</math></li> </ul>



Type	Circuit	Remarks
E		<ul style="list-style-type: none"> <li>• CMOS level output</li> <li>• CMOS level hysteresis input</li> <li>• With pull-up resistor control</li> <li>• With standby mode control</li> <li>• Pull-up resistor : Approximately 33kΩ</li> <li>• <math>I_{OH} = -4\text{mA}</math>, <math>I_{OL} = 4\text{mA}</math></li> <li>• When this pin is used as an I<sup>2</sup>C pin, the digital output P-ch transistor is always off</li> </ul>
F		<ul style="list-style-type: none"> <li>• CMOS level output</li> <li>• CMOS level hysteresis input</li> <li>• With input control</li> <li>• Analog input</li> <li>• With pull-up resistor control</li> <li>• With standby mode control</li> <li>• Pull-up resistor : Approximately 33kΩ</li> <li>• <math>I_{OH} = -4\text{mA}</math>, <math>I_{OL} = 4\text{mA}</math></li> <li>• When this pin is used as an I<sup>2</sup>C pin, the digital output P-ch transistor is always off</li> </ul>
G		<p>CMOS level hysteresis input</p>

Type	Circuit	Remarks
H	<p>The circuit diagram shows a CMOS output stage. A pull-up resistor R is connected to the output node. The output node is driven by a P-channel MOSFET (P-ch) and an N-channel MOSFET (N-ch). The P-ch MOSFET is controlled by a 'Pull-up resistor control' signal. The N-ch MOSFET is controlled by a 'Standby mode control' signal. The output node is also connected to a 'Digital output' terminal. A 'Digital input' terminal is connected to the output node through an inverter. The 'Standby mode control' signal is also connected to the inverter. The output node is also connected to a 'Digital output' terminal.</p>	<ul style="list-style-type: none"> <li>• CMOS level output</li> <li>• CMOS level hysteresis input</li> <li>• 5V tolerant</li> <li>• With pull-up resistor control</li> <li>• With standby mode control</li> <li>• Pull-up resistor : Approximately 33kΩ</li> <li>• <math>I_{OH} = -4\text{mA}</math>, <math>I_{OL} = 4\text{mA}</math></li> <li>• Available to control PZR registers.</li> <li>• When this pin is used as an I<sup>2</sup>C pin, the digital output P-ch transistor is always off</li> </ul>

## ■ HANDLING PRECAUTIONS

Any semiconductor devices have inherently a certain rate of failure. The possibility of failure is greatly affected by the conditions in which they are used (circuit conditions, environmental conditions, etc.). This page describes precautions that must be observed to minimize the chance of failure and to obtain higher reliability from your Spansion semiconductor devices.

### 1. Precautions for Product Design

This section describes precautions when designing electronic equipment using semiconductor devices.

- **Absolute Maximum Ratings**

Semiconductor devices can be permanently damaged by application of stress (voltage, current, temperature, etc.) in excess of certain established limits, called absolute maximum ratings. Do not exceed these ratings.

- **Recommended Operating Conditions**

Recommended operating conditions are normal operating ranges for the semiconductor device. All the device's electrical characteristics are warranted when operated within these ranges.

Always use semiconductor devices within the recommended operating conditions. Operation outside these ranges may adversely affect reliability and could result in device failure.

No warranty is made with respect to uses, operating conditions, or combinations not represented on the data sheet. Users considering application outside the listed conditions are advised to contact their sales representative beforehand.

- **Processing and Protection of Pins**

These precautions must be followed when handling the pins which connect semiconductor devices to power supply and input/output functions.

- (1) **Preventing Over-Voltage and Over-Current Conditions**

Exposure to voltage or current levels in excess of maximum ratings at any pin is likely to cause deterioration within the device, and in extreme cases leads to permanent damage of the device. Try to prevent such overvoltage or over-current conditions at the design stage.

- (2) **Protection of Output Pins**

Shorting of output pins to supply pins or other output pins, or connection to large capacitance can cause large current flows. Such conditions if present for extended periods of time can damage the device.

Therefore, avoid this type of connection.

- (3) **Handling of Unused Input Pins**

Unconnected input pins with very high impedance levels can adversely affect stability of operation. Such pins should be connected through an appropriate resistance to a power supply pin or ground pin.

- **Latch-up**

Semiconductor devices are constructed by the formation of P-type and N-type areas on a substrate. When subjected to abnormally high voltages, internal parasitic PNP junctions (called thyristor structures) may be formed, causing large current levels in excess of several hundred mA to flow continuously at the power supply pin. This condition is called latch-up.

**CAUTION:** The occurrence of latch-up not only causes loss of reliability in the semiconductor device, but can cause injury or damage from high heat, smoke or flame. To prevent this from happening, do the following:

- (1) Be sure that voltages applied to pins do not exceed the absolute maximum ratings. This should include attention to abnormal noise, surge levels, etc.
- (2) Be sure that abnormal current flows do not occur during the power-on sequence.

- **Observance of Safety Regulations and Standards**

Most countries in the world have established standards and regulations regarding safety, protection from electromagnetic interference, etc. Customers are requested to observe applicable regulations and standards in the design of products.

- **Fail-Safe Design**

Any semiconductor devices have inherently a certain rate of failure. You must protect against injury, damage or loss from such failures by incorporating safety design measures into your facility and equipment such as redundancy, fire protection, and prevention of over-current levels and other abnormal operating conditions.

- **Precautions Related to Usage of Devices**

SpanSion semiconductor devices are intended for use in standard applications (computers, office automation and other office equipment, industrial, communications, and measurement equipment, personal or household devices, etc.).

**CAUTION:** Customers considering the use of our products in special applications where failure or abnormal operation may directly affect human lives or cause physical injury or property damage, or where extremely high levels of reliability are demanded (such as aerospace systems, atomic energy controls, sea floor repeaters, vehicle operating controls, medical devices for life support, etc.) are requested to consult with sales representatives before such use. The company will not be responsible for damages arising from such use without prior approval.

## 2. Precautions for Package Mounting

Package mounting may be either lead insertion type or surface mount type. In either case, for heat resistance during soldering, you should only mount under SpanSion's recommended conditions. For detailed information about mount conditions, contact your sales representative.

- **Lead Insertion Type**

Mounting of lead insertion type packages onto printed circuit boards may be done by two methods: direct soldering on the board, or mounting by using a socket.

Direct mounting onto boards normally involves processes for inserting leads into through-holes on the board and using the flow soldering (wave soldering) method of applying liquid solder. In this case, the soldering process usually causes leads to be subjected to thermal stress in excess of the absolute ratings for storage temperature. Mounting processes should conform to SpanSion recommended mounting conditions.

If socket mounting is used, differences in surface treatment of the socket contacts and IC lead surfaces can lead to contact deterioration after long periods. For this reason it is recommended that the surface treatment of socket contacts and IC leads be verified before mounting.

- **Surface Mount Type**

Surface mount packaging has longer and thinner leads than lead-insertion packaging, and therefore leads are more easily deformed or bent. The use of packages with higher pin counts and narrower pin pitch results in increased susceptibility to open connections caused by deformed pins, or shorting due to solder bridges.

You must use appropriate mounting techniques. SpanSion Inc. recommends the solder reflow method, and has established a ranking of mounting conditions for each product. Users are advised to mount packages in accordance with SpanSion ranking of recommended conditions.

- **Lead-Free Packaging**

CAUTION: When ball grid array (BGA) packages with Sn-Ag-Cu balls are mounted using Sn-Pb eutectic soldering, junction strength may be reduced under some conditions of use.

- **Storage of Semiconductor Devices**

Because plastic chip packages are formed from plastic resins, exposure to natural environmental conditions will cause absorption of moisture. During mounting, the application of heat to a package that has absorbed moisture can cause surfaces to peel, reducing moisture resistance and causing packages to crack. To prevent, do the following:

- (1) Avoid exposure to rapid temperature changes, which cause moisture to condense inside the product. Store products in locations where temperature changes are slight.
- (2) Use dry boxes for product storage. Products should be stored below 70% relative humidity, and at temperatures between 5°C and 30°C.  
When you open Dry Package that recommends humidity 40% to 70% relative humidity.
- (3) When necessary, Spansion Inc. packages semiconductor devices in highly moisture-resistant aluminum laminate bags, with a silica gel desiccant. Devices should be sealed in their aluminum laminate bags for storage.
- (4) Avoid storing packages where they are exposed to corrosive gases or high levels of dust.

- **Baking**

Packages that have absorbed moisture may be de-moisturized by baking (heat drying). Follow the Spansion recommended conditions for baking.

Condition: 125°C/24 h

- **Static Electricity**

Because semiconductor devices are particularly susceptible to damage by static electricity, you must take the following precautions:

- (1) Maintain relative humidity in the working environment between 40% and 70%. Use of an apparatus for ion generation may be needed to remove electricity.
- (2) Electrically ground all conveyors, solder vessels, soldering irons and peripheral equipment.
- (3) Eliminate static body electricity by the use of rings or bracelets connected to ground through high resistance (on the level of 1 MΩ).  
Wearing of conductive clothing and shoes, use of conductive floor mats and other measures to minimize shock loads is recommended.
- (4) Ground all fixtures and instruments, or protect with anti-static measures.
- (5) Avoid the use of styrofoam or other highly static-prone materials for storage of completed board assemblies.

### 3. Precautions for Use Environment

Reliability of semiconductor devices depends on ambient temperature and other conditions as described above.

For reliable performance, do the following:

(1) Humidity

Prolonged use in high humidity can lead to leakage in devices as well as printed circuit boards. If high humidity levels are anticipated, consider anti-humidity processing.

(2) Discharge of Static Electricity

When high-voltage charges exist close to semiconductor devices, discharges can cause abnormal operation. In such cases, use anti-static measures or processing to prevent discharges.

(3) Corrosive Gases, Dust, or Oil

Exposure to corrosive gases or contact with dust or oil may lead to chemical reactions that will adversely affect the device. If you use devices in such conditions, consider ways to prevent such exposure or to protect the devices.

(4) Radiation, Including Cosmic Radiation

Most devices are not designed for environments involving exposure to radiation or cosmic radiation. Users should provide shielding as appropriate.

(5) Smoke, Flame

**CAUTION:** Plastic molded devices are flammable, and therefore should not be used near combustible substances. If devices begin to smoke or burn, there is danger of the release of toxic gases.

Customers considering the use of Spansion products in other special environmental conditions should consult with sales representatives.

Please check the latest handling precautions at the following URL.  
<http://www.spansion.com/fjdocuments/fj/datasheet/e-ds/DS00-00004.pdf>

## ■ HANDLING DEVICES

### • Power supply pins

In products with multiple VCC and VSS pins, respective pins at the same potential are interconnected within the device in order to prevent malfunctions such as latch-up. However, all of these pins should be connected externally to the power supply or ground lines in order to reduce electromagnetic emission levels, to prevent abnormal operation of strobe signals caused by the rise in the ground level, and to conform to the total output current rating.

Moreover, connect the current supply source with each Power supply pin and GND pin of this device at low impedance. It is also advisable that a ceramic capacitor of approximately 0.1  $\mu$ F be connected as a bypass capacitor between each Power supply pin and GND pin near this device.

### • Stabilizing power supply voltage

A malfunction may occur when the power supply voltage fluctuates rapidly even though the fluctuation is within the recommended operating conditions of the VCC power supply voltage. As a rule, with voltage stabilization, suppress the voltage fluctuation so that the fluctuation in VCC ripple (peak-to-peak value) at the commercial frequency (50 Hz/60 Hz) does not exceed 10% of the VCC value in the recommended operating conditions, and the transient fluctuation rate does not exceed 0.1 V/ $\mu$ s when there is a momentary fluctuation on switching the power supply.

### • Crystal oscillator circuit

Noise near the X0/X1 and X0A/X1A pins may cause the device to malfunction. Design the printed circuit board so that X0/X1, X0A/X1A pins, the crystal oscillator, and the bypass capacitor to ground are located as close to the device as possible.

It is strongly recommended that the PC board artwork be designed such that the X0/X1 and X0A/X1A pins are surrounded by ground plane as this is expected to produce stable operation.

Evaluate oscillation of your using crystal oscillator by your mount board.

### • Sub crystal oscillator

This series sub oscillator circuit is low gain to keep the low current consumption.

The crystal oscillator to fill the following conditions is recommended for sub crystal oscillator to stabilize the oscillation.

#### • Surface mount type

Size : More than 3.2mm  $\times$  1.5mm

Load capacitance : Approximately 6pF to 7pF

#### • Lead type

Load capacitance : Approximately 6pF to 7pF

- Using an external clock

When using an external clock as an input of the main clock, set X0/X1 to the external clock input, and input the clock to X0. X1(PE3) can be used as a general-purpose I/O port.

Similarly, when using an external clock as an input of the sub clock, set X0A/X1A to the external clock input, and input the clock to X0A. X1A (P47) can be used as a general-purpose I/O port.

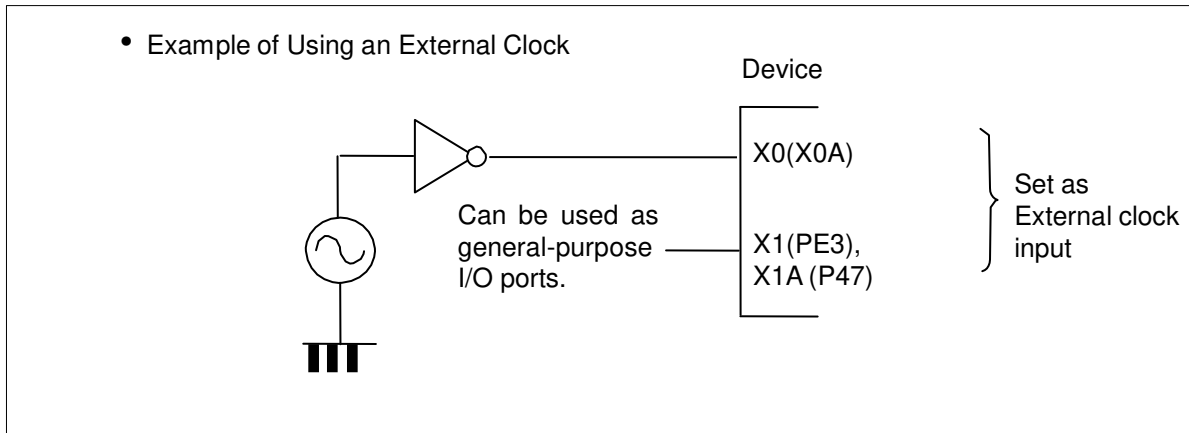

- Handling when using Multi-function serial pin as I<sup>2</sup>C pin

If it is using the multi-function serial pin as I<sup>2</sup>C pins, P-ch transistor of digital output is always disabled.

However, I<sup>2</sup>C pins need to keep the electrical characteristic like other pins and not to connect to the external I<sup>2</sup>C bus system with power OFF.

- C pin

This series contains the regulator. Be sure to connect a smoothing capacitor (C<sub>S</sub>) for the regulator between the C pin and the GND pin. Please use a ceramic capacitor or a capacitor of equivalent frequency characteristics as a smoothing capacitor.

However, some laminated ceramic capacitors have the characteristics of capacitance variation due to thermal fluctuation (F characteristics and Y5V characteristics). Please select the capacitor that meets the specifications in the operating conditions to use by evaluating the temperature characteristics of a capacitor. A smoothing capacitor of about 4.7uF would be recommended for this series.

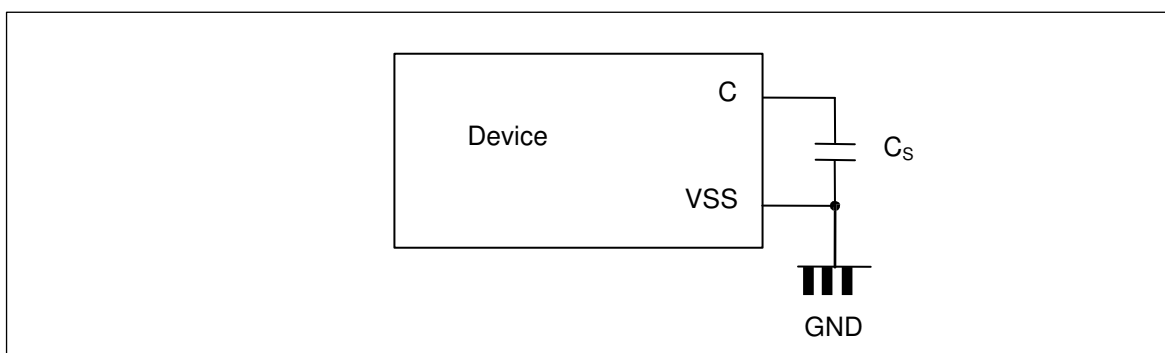

- Mode pins (MD0)

Connect the MD pin (MD0) directly to VCC or VSS pins. Design the printed circuit board such that the pull-up/down resistor stays low, as well as the distance between the mode pins and VCC pins or VSS pins is as short as possible and the connection impedance is low, when the pins are pulled-up/down such as for switching the pin level and rewriting the Flash memory data. It is because of preventing the device erroneously switching to test mode due to noise.



- **Notes on power-on**

Turn power on/off in the following order or at the same time.

If not using the A/D converter, connect AVCC = VCC and AVSS = VSS.

Turning on : VCC → AVCC → AVRH

Turning off : AVRH → AVCC → VCC

- **Serial Communication**

There is a possibility to receive wrong data due to the noise or other causes on the serial communication.

Therefore, design a printed circuit board so as to avoid noise.

Consider the case of receiving wrong data due to noise, perform error detection such as by applying a checksum of data at the end. If an error is detected, retransmit the data.

- **Differences in features among the products with different memory sizes and between Flash memory products and MASK products**

The electric characteristics including power consumption, ESD, latch-up, noise characteristics, and oscillation characteristics among the products with different memory sizes and between Flash memory products and MASK products are different because chip layout and memory structures are different.

If you are switching to use a different product of the same series, please make sure to evaluate the electric characteristics.

- **Pull-Up function of 5V tolerant I/O**

Please do not input the signal more than VCC voltage at the time of Pull-Up function use of 5V tolerant I/O.

■ BLOCK DIAGRAM

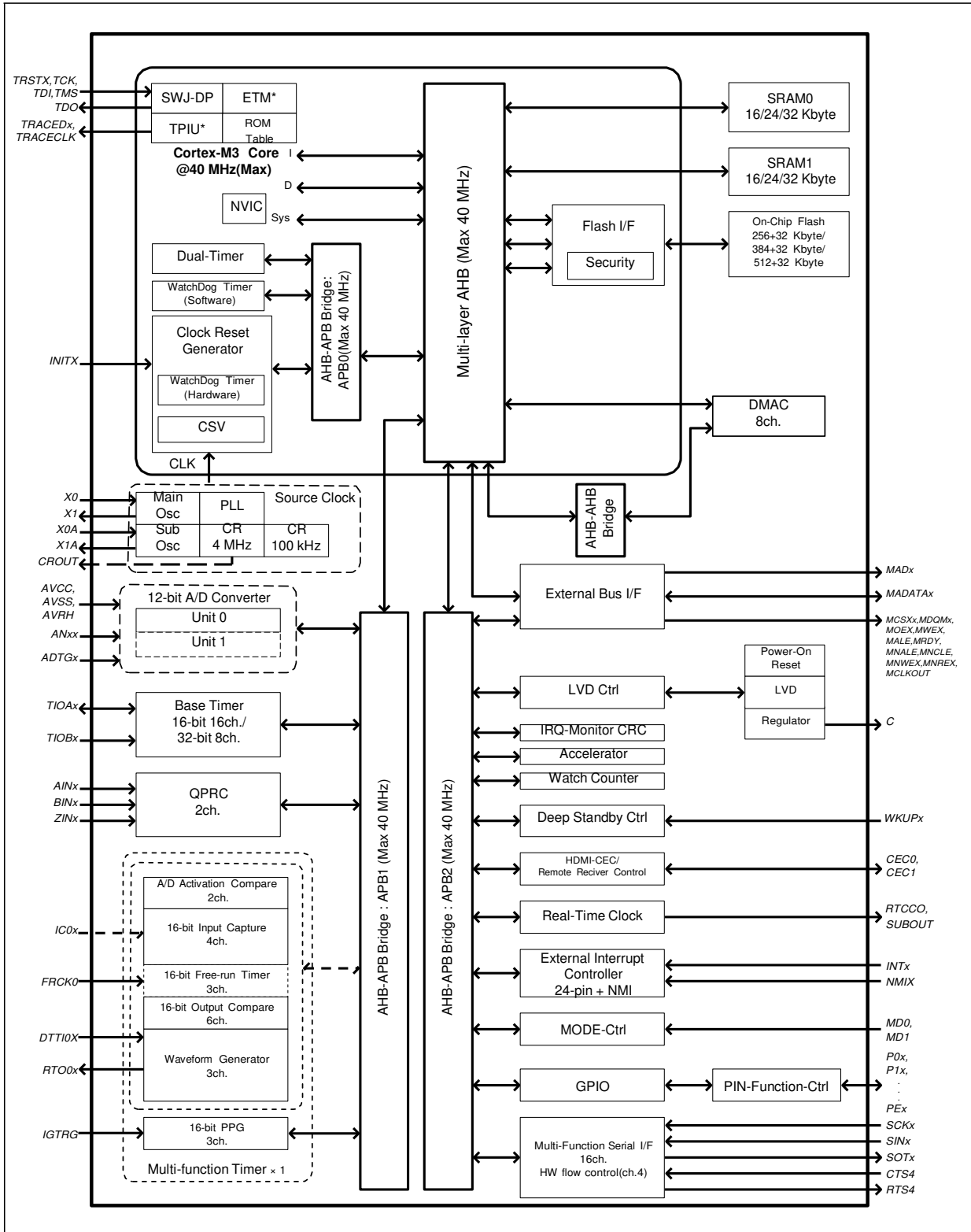

\*: For the MB9AF154MA, MB9AF155MA, and MB9AF156MA, ETM is not available.

■ MEMORY SIZE

See " • Memory size" in " ■PRODUCT LINEUP" to confirm the memory size.

## MEMORY MAP

### Memory Map (1)

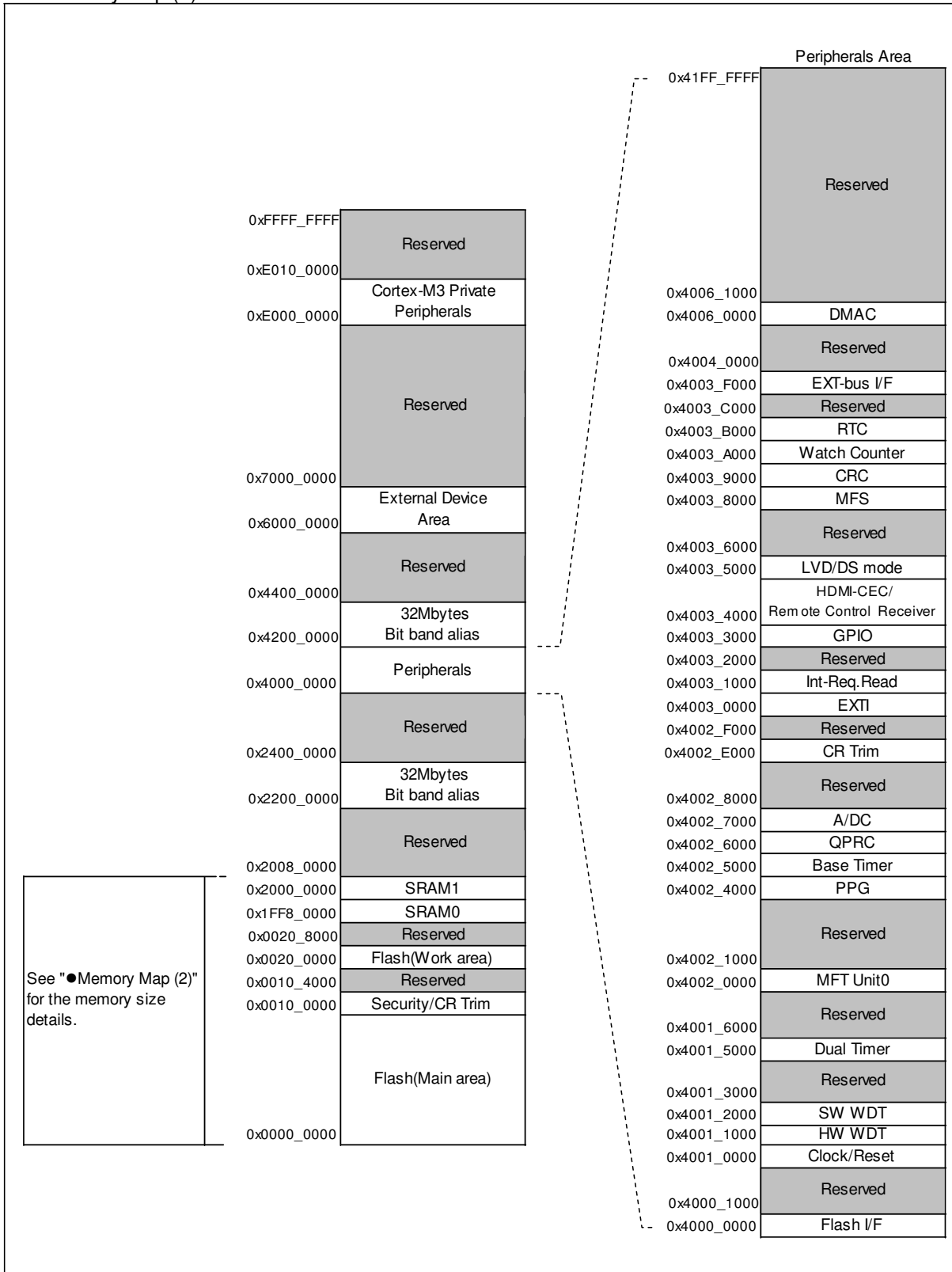

See "●Memory Map (2)" for the memory size details.

● Memory Map (2)

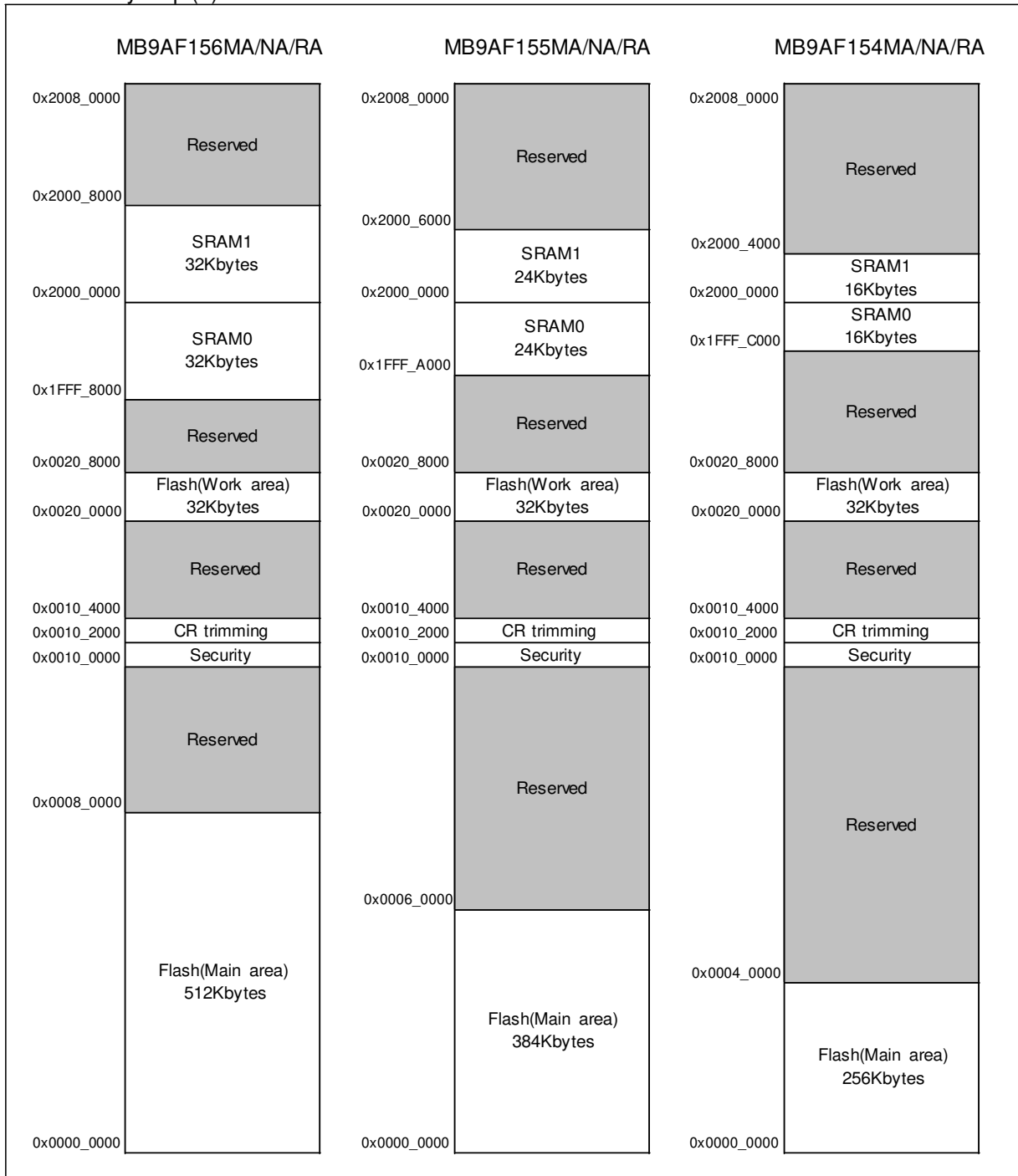

For more information about Flash (Main area)/Flash (Work area), see "MB9AB40N/A40N/340N/140N/150R, MB9B520M/320M/120M Series Flash Programming Manual".

## ● Peripheral Address Map

Start address	End address	Bus	Peripherals
0x4000_0000	0x4000_0FFF	AHB	Flash memory I/F register
0x4000_1000	0x4000_FFFF		Reserved
0x4001_0000	0x4001_0FFF	APB0	Clock/Reset Control
0x4001_1000	0x4001_1FFF		Hardware Watchdog timer
0x4001_2000	0x4001_2FFF		Software Watchdog timer
0x4001_3000	0x4001_4FFF		Reserved
0x4001_5000	0x4001_5FFF		Dual Timer
0x4001_6000	0x4001_FFFF		Reserved
0x4002_0000	0x4002_0FFF		APB1
0x4002_1000	0x4002_3FFF	Reserved	
0x4002_4000	0x4002_4FFF	PPG	
0x4002_5000	0x4002_5FFF	Base Timer	
0x4002_6000	0x4002_6FFF	Quadrature Position/Revolution Counter	
0x4002_7000	0x4002_7FFF	A/D Converter	
0x4002_8000	0x4002_DFFF	Reserved	
0x4002_E000	0x4002_EFFF	Built-in CR trimming	
0x4002_F000	0x4002_FFFF	Reserved	
0x4003_0000	0x4003_0FFF	APB2	
0x4003_1000	0x4003_1FFF		Interrupt Source Check Register
0x4003_2000	0x4003_2FFF		Reserved
0x4003_3000	0x4003_3FFF		GPIO
0x4003_4000	0x4003_4FFF		HDMI-CEC/Remote control Reception
0x4003_5000	0x4003_57FF		Low-Voltage Detector
0x4003_5800	0x4003_5FFF		Deep standby mode Controller
0x4003_6000	0x4003_7FFF		Reserved
0x4003_8000	0x4003_8FFF		Multi-function serial
0x4003_9000	0x4003_9FFF		CRC
0x4003_A000	0x4003_AFFF		Watch Counter
0x4003_B000	0x4003_BFFF		Real-time clock
0x4003_C000	0x4003_EFFF		Reserved
0x4003_F000	0x4003_FFFF		External bus interface
0x4004_0000	0x4005_FFFF		AHB
0x4006_0000	0x4006_0FFF	DMAC register	
0x4006_1000	0x41FF_FFFF	Reserved	

## ■ PIN STATUS IN EACH CPU STATE

The terms used for pin status have the following meanings.

- INITX=0

This is the period when the INITX pin is the "L" level.

- INITX=1

This is the period when the INITX pin is the "H" level.

- SPL=0

This is the status that the standby pin level setting bit (SPL) in the standby mode control register (STB\_CTL) is set to "0".

- SPL=1

This is the status that the standby pin level setting bit (SPL) in the standby mode control register (STB\_CTL) is set to "1".

- Input enabled

Indicates that the input function can be used.

- Internal input fixed at "0"

This is the status that the input function cannot be used. Internal input is fixed at "L".

- Hi-Z

Indicates that the pin drive transistor is disabled and the pin is put in the Hi-Z state.

- Setting disabled

Indicates that the setting is disabled.

- Maintain previous state

Maintains the state that was immediately prior to entering the current mode.

If a built-in peripheral function is operating, the output follows the peripheral function.

If the pin is being used as a port, that output is maintained.

- Analog input is enabled

Indicates that the analog input is enabled.

- Trace output

Indicates that the trace function can be used.

- GPIO selected

In Deep standby mode, pins switch to the general-purpose I/O port.

● List of Pin Status

Pin status type	Function group	Power-on reset or low-voltage detection state	INITX input state	Device internal reset state	Run mode or SLEEP mode state	TIMER mode, RTC mode, or STOP mode state		Deep standby RTC mode or Deep standby STOP mode state		Return from Deep standby mode state
		Power supply unstable	Power supply stable		Power supply stable	Power supply stable		Power supply stable		Power supply stable
		-	INITX = 0	INITX = 1	INITX = 1	INITX = 1		INITX = 1		INITX = 1
		-	-	-	-	SPL = 0	SPL = 1	SPL = 0	SPL = 1	-
A	GPIO selected	Setting disabled	Setting disabled	Setting disabled	Maintain previous state	Maintain previous state	Hi-Z / Internal input fixed at "0"	GPIO selected Internal input fixed at "0"	Hi-Z / Internal input fixed at "0"	GPIO selected
	Main crystal oscillator input pin/ External main clock input selected	Input enabled	Input enabled	Input enabled	Input enabled	Input enabled	Input enabled	Input enabled	Input enabled	Input enabled
B	GPIO selected	Setting disabled	Setting disabled	Setting disabled	Maintain previous state	Maintain previous state	Hi-Z / Internal input fixed at "0"	GPIO selected Internal input fixed at "0"	Hi-Z / Internal input fixed at "0"	GPIO selected
	External main clock input selected	Setting disabled	Setting disabled	Setting disabled	Maintain previous state	Maintain previous state	Hi-Z / Internal input fixed at "0"	Maintain previous state	Hi-Z / Internal input fixed at "0"	Maintain previous state
	Main crystal oscillator output pin	Hi-Z / Internal input fixed at "0" / or Input enable	Hi-Z / Internal input fixed at "0"	Hi-Z / Internal input fixed at "0"	Maintain previous state/When oscillation stops* <sup>1</sup> , Hi-Z / Internal input fixed at "0"	Maintain previous state/When oscillation stops* <sup>1</sup> , Hi-Z / Internal input fixed at "0"	Maintain previous state/When oscillation stops* <sup>1</sup> , Hi-Z / Internal input fixed at "0"	Maintain previous state/When oscillation stops* <sup>1</sup> , Hi-Z / Internal input fixed at "0"	Maintain previous state/When oscillation stops* <sup>1</sup> , Hi-Z / Internal input fixed at "0"	Maintain previous state/When oscillation stops* <sup>1</sup> , Hi-Z / Internal input fixed at "0"
C	INITX input pin	Pull-up / Input enabled	Pull-up / Input enabled	Pull-up / Input enabled	Pull-up / Input enabled	Pull-up / Input enabled	Pull-up / Input enabled	Pull-up / Input enabled	Pull-up / Input enabled	Pull-up / Input enabled
D	Mode input pin	Input enabled	Input enabled	Input enabled	Input enabled	Input enabled	Input enabled	Input enabled	Input enabled	Input enabled
E	Mode input pin	Input enabled	Input enabled	Input enabled	Input enabled	Input enabled	Input enabled	Input enabled	Input enabled	Input enabled
	GPIO selected	Setting disabled	Setting disabled	Setting disabled	Maintain previous state	Maintain previous state	Hi-Z / Input enabled	GPIO selected	Hi-Z / Input enabled	GPIO selected

Pin status type	Function group	Power-on reset or low-voltage detection state	INITX input state	Device internal reset state	Run mode or SLEEP mode state	TIMER mode, RTC mode, or STOP mode state		Deep standby RTC mode or Deep standby STOP mode state		Return from Deep standby mode state
		Power supply unstable	Power supply stable		Power supply stable	Power supply stable		Power supply stable		Power supply stable
		-	INITX = 0	INITX = 1	INITX = 1	INITX = 1		INITX = 1		INITX = 1
		-	-	-	-	SPL = 0	SPL = 1	SPL = 0	SPL = 1	-
F	GPIO selected	Setting disabled	Setting disabled	Setting disabled	Maintain previous state	Maintain previous state	Hi-Z / Internal input fixed at "0"	GPIO selected Internal input fixed at "0"	Hi-Z / Internal input fixed at "0"	GPIO selected
	Sub crystal oscillator input pin / External sub clock input selected	Input enabled	Input enabled	Input enabled	Input enabled	Input enabled	Input enabled	Input enabled	Input enabled	Input enabled
G	GPIO selected	Setting disabled	Setting disabled	Setting disabled	Maintain previous state	Maintain previous state	Hi-Z / Internal input fixed at "0"	GPIO selected Internal input fixed at "0"	Hi-Z / Internal input fixed at "0"	GPIO selected
	External sub clock input selected	Setting disabled	Setting disabled	Setting disabled	Maintain previous state	Maintain previous state	Hi-Z / Internal input fixed at "0"	Maintain previous state	Hi-Z / Internal input fixed at "0"	Maintain previous state
	Sub crystal oscillator output pin	Hi-Z / Internal input fixed at "0" / or Input enable	Hi-Z / Internal input fixed at "0"	Hi-Z / Internal input fixed at "0"	Maintain previous state	Maintain previous state / When oscillation stops*2, Hi-Z / Internal input fixed at "0"	Maintain previous state / When oscillation stops*2, Hi-Z / Internal input fixed at "0"	Maintain previous state / When oscillation stops*2, Hi-Z / Internal input fixed at "0"	Maintain previous state / When oscillation stops*2, Hi-Z / Internal input fixed at "0"	Maintain previous state / When oscillation stops*2, Hi-Z / Internal input fixed at "0"
H	NMIX selected	Setting disabled	Setting disabled	Setting disabled	Maintain previous state	Maintain previous state	Maintain previous state	WKUP input enabled	Hi-Z / WKUP input enabled	GPIO selected
	Resource other than above selected	Hi-Z	Hi-Z / Input enabled	Hi-Z / Input enabled		Maintain previous state	Hi-Z / Internal input fixed at "0"			
	GPIO selected									



Pin status type	Function group	Power-on reset or low-voltage detection state	INITX input state	Device internal reset state	Run mode or SLEEP mode state	TIMER mode, RTC mode, or STOP mode state		Deep standby RTC mode or Deep standby STOP mode state		Return from Deep standby mode state
		Power supply unstable	Power supply stable		Power supply stable	Power supply stable		Power supply stable		Power supply stable
		-	INITX = 0	INITX = 1	INITX = 1	INITX = 1		INITX = 1		INITX = 1
		-	-	-	-	SPL = 0	SPL = 1	SPL = 0	SPL = 1	-
I	JTAG selected	Hi-Z	Pull-up / Input enabled	Pull-up / Input enabled	Maintain previous state	Maintain previous state	Maintain previous state	Maintain previous state	Maintain previous state	Maintain previous state
	Resource selected	Setting disabled	Setting disabled	Setting disabled	Maintain previous state	Maintain previous state	Maintain previous state	Maintain previous state	Maintain previous state	Maintain previous state
	GPIO selected						Hi-Z / Internal input fixed at "0"	GPIO selected Internal input fixed at "0"	Hi-Z / Internal input fixed at "0"	GPIO selected
J	Resource selected	Hi-Z	Hi-Z / Input enabled	Hi-Z / Input enabled	Maintain previous state	Maintain previous state	Hi-Z / Internal input fixed at "0"	GPIO selected Internal input fixed at "0"	Hi-Z / Internal input fixed at "0"	GPIO selected
	GPIO selected						Hi-Z / Internal input fixed at "0"	GPIO selected		
K	External interrupt enabled selected	Setting disabled	Setting disabled	Setting disabled	Maintain previous state	Maintain previous state	Maintain previous state	GPIO selected Internal input fixed at "0"	Hi-Z / Internal input fixed at "0"	GPIO selected
	Resource other than above selected	Hi-Z	Hi-Z / Input enabled	Hi-Z / Input enabled			Hi-Z / Internal input fixed at "0"			
	GPIO selected				Hi-Z / Internal input fixed at "0"					
L	Analog input selected	Hi-Z	Hi-Z / Internal input fixed at "0" / Analog input enabled	Hi-Z / Internal input fixed at "0" / Analog input enabled	Hi-Z / Internal input fixed at "0" / Analog input enabled	Hi-Z / Internal input fixed at "0" / Analog input enabled	Hi-Z / Internal input fixed at "0" / Analog input enabled	Hi-Z / Internal input fixed at "0" / Analog input enabled	Hi-Z / Internal input fixed at "0" / Analog input enabled	Hi-Z / Internal input fixed at "0" / Analog input enabled
	Resource other than above selected	Setting disabled	Setting disabled	Setting disabled	Maintain previous state	Maintain previous state	Hi-Z / Internal input fixed at "0"	GPIO selected Internal input fixed at "0"	Hi-Z / Internal input fixed at "0"	GPIO selected
	GPIO selected						Hi-Z / Internal input fixed at "0"			
M	Analog input selected	Hi-Z	Hi-Z / Internal input fixed at "0" / Analog input enabled	Hi-Z / Internal input fixed at "0" / Analog input enabled	Hi-Z / Internal input fixed at "0" / Analog input enabled	Hi-Z / Internal input fixed at "0" / Analog input enabled	Hi-Z / Internal input fixed at "0" / Analog input enabled	Hi-Z / Internal input fixed at "0" / Analog input enabled	Hi-Z / Internal input fixed at "0" / Analog input enabled	Hi-Z / Internal input fixed at "0" / Analog input enabled
	External interrupt enabled selected	Setting disabled	Setting disabled	Setting disabled	Maintain previous state	Maintain previous state	Maintain previous state	GPIO selected Internal input fixed at "0"	Hi-Z / Internal input fixed at "0"	GPIO selected
	Resource other than above selected						Hi-Z / Internal input fixed at "0"			
	GPIO selected						Hi-Z / Internal input fixed at "0"			

Pin status type	Function group	Power-on reset or low-voltage detection state	INITX input state	Device internal reset state	Run mode or SLEEP mode state	TIMER mode, RTC mode, or STOP mode state		Deep standby RTC mode or Deep standby STOP mode state		Return from Deep standby mode state
		Power supply unstable	Power supply stable		Power supply stable	Power supply stable		Power supply stable		Power supply stable
		-	INITX = 0	INITX = 1	INITX = 1	INITX = 1		INITX = 1		INITX = 1
		-	-	-	-	SPL = 0	SPL = 1	SPL = 0	SPL = 1	-
N	Analog input selected	Hi-Z	Hi-Z / Internal input fixed at "0" / Analog input enabled	Hi-Z / Internal input fixed at "0" / Analog input enabled	Hi-Z / Internal input fixed at "0" / Analog input enabled	Hi-Z / Internal input fixed at "0" / Analog input enabled	Hi-Z / Internal input fixed at "0" / Analog input enabled	Hi-Z / Internal input fixed at "0" / Analog input enabled	Hi-Z / Internal input fixed at "0" / Analog input enabled	Hi-Z / Internal input fixed at "0" / Analog input enabled
	Trace selected	Setting disabled	Setting disabled	Setting disabled	Maintain previous state	Maintain previous state	Trace output	GPIO selected Internal input fixed at "0"	Hi-Z / Internal input fixed at "0"	GPIO selected
	Resource other than above selected						Hi-Z / Internal input fixed at "0"			
GPIO selected										
O	Analog input selected	Hi-Z	Hi-Z / Internal input fixed at "0" / Analog input enabled	Hi-Z / Internal input fixed at "0" / Analog input enabled	Hi-Z / Internal input fixed at "0" / Analog input enabled	Hi-Z / Internal input fixed at "0" / Analog input enabled	Hi-Z / Internal input fixed at "0" / Analog input enabled	Hi-Z / Internal input fixed at "0" / Analog input enabled	Hi-Z / Internal input fixed at "0" / Analog input enabled	Hi-Z / Internal input fixed at "0" / Analog input enabled
	Trace selected	Setting disabled	Setting disabled	Setting disabled	Maintain previous state	Maintain previous state	Trace output	GPIO selected Internal input fixed at "0"	Hi-Z / Internal input fixed at "0"	GPIO selected
	External interrupt enabled selected						Maintain previous state			
	Resource other than above selected						Hi-Z / Internal input fixed at "0"			
	GPIO selected									
P	Analog input selected	Hi-Z	Hi-Z / Internal input fixed at "0" / Analog input enabled	Hi-Z / Internal input fixed at "0" / Analog input enabled	Hi-Z / Internal input fixed at "0" / Analog input enabled	Hi-Z / Internal input fixed at "0" / Analog input enabled	Hi-Z / Internal input fixed at "0" / Analog input enabled	Hi-Z / Internal input fixed at "0" / Analog input enabled	Hi-Z / Internal input fixed at "0" / Analog input enabled	Hi-Z / Internal input fixed at "0" / Analog input enabled
	WKUP enabled	Setting disabled	Setting disabled	Setting disabled	Maintain previous state	Maintain previous state	Maintain previous state	WKUP input enabled	Hi-Z / WKUP input enabled	GPIO selected
	External interrupt enabled selected						GPIO selected Internal input fixed at "0"	Hi-Z / Internal input fixed at "0"		
	Resource other than above selected						Hi-Z / Internal input fixed at "0"			
GPIO selected										

Pin status type	Function group	Power-on reset or low-voltage detection state	INITX input state	Device internal reset state	Run mode or SLEEP mode state	TIMER mode, RTC mode, or STOP mode state		Deep standby RTC mode or Deep standby STOP mode state		Return from Deep standby mode state	
		Power supply unstable	Power supply stable		Power supply stable	Power supply stable		Power supply stable		Power supply stable	
		-	INITX = 0	INITX = 1	INITX = 1	INITX = 1		INITX = 1		INITX = 1	
		-	-	-	-	SPL = 0	SPL = 1	SPL = 0	SPL = 1	-	
Q	CEC enabled	Setting disabled	Setting disabled	Setting disabled	Maintain previous state	Maintain previous state	Maintain previous state	Maintain previous state	Maintain previous state	Maintain previous state	
	WKUP enabled	Setting disabled	Setting disabled	Setting disabled	Maintain previous state	Maintain previous state	Maintain previous state	WKUP input enabled	Hi-Z / WKUP input enabled	GPIO selected	
	External interrupt enabled selected	Hi-Z	Hi-Z / Input enabled	Hi-Z / Input enabled			Hi-Z / Internal input fixed at "0"	Hi-Z / Internal input fixed at "0"	GPIO selected Internal input fixed at "0"		Hi-Z / Internal input fixed at "0"
	Resource other than above selected										
	GPIO selected										
R	CEC enabled	Setting disabled	Setting disabled	Setting disabled	Maintain previous state	Maintain previous state	Maintain previous state	Maintain previous state	Maintain previous state	Maintain previous state	
	External interrupt enabled selected	Setting disabled	Setting disabled	Setting disabled	Maintain previous state	Maintain previous state	Maintain previous state	GPIO selected Internal input fixed at "0"	Hi-Z / Internal input fixed at "0"	GPIO selected	
	Resource other than above selected	Hi-Z	Hi-Z / Input enabled	Hi-Z / Input enabled			Hi-Z / Internal input fixed at "0"				
	GPIO selected										
S	WKUP enabled	Setting disabled	Setting disabled	Setting disabled	Maintain previous state	Maintain previous state	Maintain previous state	WKUP input enabled	Hi-Z / WKUP input enabled	GPIO selected	
	External interrupt enabled selected	Hi-Z	Hi-Z / Input enabled	Hi-Z / Input enabled			Hi-Z / Internal input fixed at "0"	Hi-Z / Internal input fixed at "0"	GPIO selected Internal input fixed at "0"		Hi-Z / Internal input fixed at "0"
	Resource other than above selected										
	GPIO selected										

\*1: Oscillation is stopped at Sub timer mode, Low-speed CR timer mode, RTC mode, STOP mode, Deep standby RTC mode, and Deep standby STOP mode.

\*2: Oscillation is stopped at STOP mode and Deep standby STOP mode.

## ■ ELECTRICAL CHARACTERISTICS

### 1. Absolute Maximum Ratings

Parameter	Symbol	Rating		Unit	Remarks
		Min	Max		
Power supply voltage <sup>*1, *2</sup>	$V_{CC}$	$V_{SS} - 0.5$	$V_{SS} + 4.6$	V	
Analog power supply voltage <sup>*1, *3</sup>	$AV_{CC}$	$V_{SS} - 0.5$	$V_{SS} + 4.6$	V	
Analog reference voltage <sup>*1, *3</sup>	$AVRH$	$V_{SS} - 0.5$	$V_{SS} + 4.6$	V	
Input voltage <sup>*1</sup>	$V_I$	$V_{SS} - 0.5$	$V_{CC} + 0.5$ ( $\leq 4.6V$ )	V	
		$V_{SS} - 0.5$	$V_{SS} + 6.5$	V	5V tolerant
Analog pin input voltage <sup>*1</sup>	$V_{IA}$	$V_{SS} - 0.5$	$AV_{CC} + 0.5$ ( $\leq 4.6V$ )	V	
Output voltage <sup>*1</sup>	$V_O$	$V_{SS} - 0.5$	$V_{CC} + 0.5$ ( $\leq 4.6V$ )	V	
"L" level maximum output current <sup>*4</sup>	$I_{OL}$	-	10	mA	
"L" level average output current <sup>*5</sup>	$I_{OLAV}$	-	4	mA	
"L" level total maximum output current	$\sum I_{OL}$	-	100	mA	
"L" level total average output current <sup>*6</sup>	$\sum I_{OLAV}$	-	50	mA	
"H" level maximum output current <sup>*4</sup>	$I_{OH}$	-	- 10	mA	
"H" level average output current <sup>*5</sup>	$I_{OHAV}$	-	- 4	mA	
"H" level total maximum output current	$\sum I_{OH}$	-	- 100	mA	
"H" level total average output current <sup>*6</sup>	$\sum I_{OHAV}$	-	- 50	mA	
Power consumption	$P_D$	-	300	mW	
Storage temperature	$T_{STG}$	- 55	+ 150	°C	

\*1 : These parameters are based on the condition that  $V_{SS} = AV_{SS} = 0.0V$ .

\*2 :  $V_{CC}$  must not drop below  $V_{SS} - 0.5V$ .

\*3 : Ensure that the voltage does not exceed  $V_{CC} + 0.5 V$ , for example, when the power is turned on.

\*4 : The maximum output current is defined as the value of the peak current flowing through any one of the corresponding pins.

\*5 : The average output current is defined as the average current value flowing through any one of the corresponding pins for a 100 ms period.

\*6 : The total average output current is defined as the average current value flowing through all of corresponding pins for a 100ms.

### <WARNING>

Semiconductor devices may be permanently damaged by application of stress (including, without limitation, voltage, current or temperature) in excess of absolute maximum ratings.

Do not exceed any of these ratings.

## 2. Recommended Operating Conditions

( $V_{SS} = AV_{SS} = 0.0V$ )

Parameter	Symbol	Conditions	Value		Unit	Remarks
			Min	Max		
Power supply voltage	$V_{CC}$	-	1.65* <sup>2</sup>	3.6	V	
Analog power supply voltage	$AV_{CC}$	-	1.65	3.6	V	$AV_{CC} = V_{CC}$
Analog reference voltage	AVRH	-	2.7	$AV_{CC}$	V	$AV_{CC} \geq 2.7V$
			$AV_{CC}$	$AV_{CC}$	V	$AV_{CC} < 2.7V$
Smoothing capacitor	$C_S$	-	1	10	$\mu F$	For Regulator * <sup>1</sup>
Operating temperature	$T_a$	-	- 40	+ 85	$^{\circ}C$	

\*1 : See "• C Pin" in "■ HANDLING DEVICES" for the connection of the smoothing capacitor.

\*2 : In between less than the minimum power supply voltage and low voltage reset/interrupt detection voltage or more, instruction execution and low voltage detection function by built-in High-speed CR(including Main PLL is used) or built-in Low-speed CR is possible to operate only.

### <WARNING>

The recommended operating conditions are required in order to ensure the normal operation of the semiconductor device. All of the device's electrical characteristics are warranted when the device is operated under these conditions.

Any use of semiconductor devices will be under their recommended operating condition.

Operation under any conditions other than these conditions may adversely affect reliability of device and could result in device failure.

No warranty is made with respect to any use, operating conditions or combinations not represented on this data sheet. If you are considering application under any conditions other than listed herein, please contact sales representatives beforehand.

### 3. DC Characteristics

#### (1) Current rating

( $V_{CC} = AV_{CC} = 1.65V$  to  $3.6V$ ,  $V_{SS} = AV_{SS} = 0V$ ,  $T_a = -40^{\circ}C$  to  $+85^{\circ}C$ )

Parameter	Symbol	Pin name	Conditions		Value		Unit	Remarks
					Typ	Max		
Power supply current	$I_{CC}$	VCC	Normal operation (PLL)	CPU : 40 MHz, Peripheral : 40 MHz * <sup>1</sup> , * <sup>3</sup>	17.5	23.7	mA	
				CPU : 40 MHz, Peripheral : the clock stops NOP operation * <sup>1</sup> , * <sup>3</sup>	8	11	mA	
			Normal operation (built-in high-speed CR)	CPU/ Peripheral : 4 MHz* <sup>2</sup> * <sup>1</sup>	1.9	3.1	mA	
			Normal operation (sub oscillation)	CPU/ Peripheral : 32 kHz * <sup>1</sup> , * <sup>4</sup>	120	810	$\mu A$	
			Normal operation (built-in low-speed CR)	CPU/ Peripheral : 100 kHz * <sup>1</sup>	140	830	$\mu A$	
	$I_{CCS}$		SLEEP operation (PLL)	Peripheral : 40 MHz * <sup>1</sup> , * <sup>3</sup>	11	15	mA	
			SLEEP operation (built-in high-speed CR)	Peripheral : 4 MHz* <sup>2</sup> * <sup>1</sup>	0.82	1.7	mA	
			SLEEP operation (sub oscillation)	Peripheral : 32 kHz * <sup>1</sup> , * <sup>4</sup>	105	800	$\mu A$	
			SLEEP operation (built-in low-speed CR)	Peripheral : 100 kHz * <sup>1</sup>	125	810	$\mu A$	
	$I_{CCH}$		STOP mode	$T_a = +25^{\circ}C$ , When LVD is off * <sup>1</sup>	11	38	$\mu A$	
				$T_a = +85^{\circ}C$ , When LVD is off * <sup>1</sup>	-	370	$\mu A$	
	$I_{CCT}$		TIMER mode (sub oscillation)	$T_a = +25^{\circ}C$ , When LVD is off * <sup>1</sup> , * <sup>4</sup>	15	45	$\mu A$	
				$T_a = +85^{\circ}C$ , When LVD is off * <sup>1</sup> , * <sup>4</sup>	-	440	$\mu A$	
	$I_{CCR}$		RTC mode (sub oscillation)	$T_a = +25^{\circ}C$ , When LVD is off * <sup>1</sup> , * <sup>4</sup>	13	40	$\mu A$	
				$T_a = +85^{\circ}C$ , When LVD is off * <sup>1</sup> , * <sup>4</sup>	-	380	$\mu A$	

\*1: When all ports are fixed.

\*2: When setting it to 4 MHz by trimming.

\*3: When using the crystal oscillator of 4 MHz(Including the current consumption of the oscillation circuit)

\*4: When using the crystal oscillator of 32 kHz(Including the current consumption of the oscillation circuit)

Parameter	Symbol	Pin name	Conditions	Value		Unit	Remarks	
				Typ	Max			
Power supply current	I <sub>CCHD</sub>	VCC	Deep Standby STOP mode	Ta = + 25°C, When LVD is off, When RAM is off *1, *3	1.4	10	μA	
				Ta = + 25°C, When LVD is off, When RAM is on *1, *3	8.6	23	μA	
				Ta = + 85°C, When LVD is off, When RAM is off *1, *3	-	120	μA	
				Ta = + 85°C, When LVD is off, When RAM is on *1, *3	-	190	μA	
	I <sub>CCRD</sub>		Deep Standby RTC mode (sub oscillation)	Ta = + 25°C, When LVD is off, When RAM is off *1, *3, *5	2.0	12	μA	
				Ta = + 25°C, When LVD is off, When RAM is on *1, *3, *5	9.2	25	μA	
				Ta = + 85°C, When LVD is off, When RAM is off *1, *3, *5	-	125	μA	
				Ta = + 85°C, When LVD is off, When RAM is on *1, *3, *5	-	195	μA	
Low-voltage detection circuit (LVD) power supply current	I <sub>CCLVD</sub>	At operation	-	0.13	0.3	μA	For occurrence of reset	
			-	0.13	0.3	μA	For occurrence of interrupt	
Flash Memory Write/Erase current	I <sub>CCFLASH</sub>	At Write/Erase	-	9.5	11.2	mA	*4	

\*1: When all ports are fixed.

\*2: When setting it to 4 MHz by trimming.

\*3: RAM on/off setting is on-chip SRAM only.

\*4: The current at which to write or erase Flash memory, "I<sub>CCFLASH</sub>" is added to "I<sub>CC</sub>".

\*5: When using the crystal oscillator of 32 kHz(Including the current consumption of the oscillation circuit)

(2) Pin Characteristics

( $V_{CC} = AV_{CC} = 1.65V$  to  $3.6V$ ,  $V_{SS} = AV_{SS} = 0V$ ,  $T_a = -40^{\circ}C$  to  $+85^{\circ}C$ )

Parameter	Symbol	Pin name	Conditions	Value			Unit	Remarks
				Min	Typ	Max		
"H" level input voltage (hysteresis input)	$V_{IHS}$	CMOS hysteresis input pin, MD0, MD1	$V_{CC} \geq 2.7 V$	$V_{CC} \times 0.8$	-	$V_{CC} + 0.3$	V	
			$V_{CC} < 2.7 V$	$V_{CC} \times 0.7$				
		5V tolerant input pin	$V_{CC} \geq 2.7 V$	$V_{CC} \times 0.8$	-	$V_{SS} + 5.5$	V	
			$V_{CC} < 2.7 V$	$V_{CC} \times 0.7$				
"L" level input voltage (hysteresis input)	$V_{ILS}$	CMOS hysteresis input pin, MD0, MD1	$V_{CC} \geq 2.7 V$	$V_{SS} - 0.3$	-	$V_{CC} \times 0.2$	V	
			$V_{CC} < 2.7 V$			$V_{CC} \times 0.3$		
		5V tolerant input pin	$V_{CC} \geq 2.7 V$	$V_{SS} - 0.3$	-	$V_{CC} \times 0.2$	V	
			$V_{CC} < 2.7 V$			$V_{CC} \times 0.3$		
"H" level output voltage	$V_{OH}$	4mA type	$V_{CC} \geq 2.7 V$ , $I_{OH} = -4mA$	$V_{CC} - 0.5$	-	$V_{CC}$	V	
			$V_{CC} < 2.7 V$ , $I_{OH} = -2mA$	$V_{CC} - 0.45$				
"L" level output voltage	$V_{OL}$	4mA type	$V_{CC} \geq 2.7 V$ , $I_{OL} = 4mA$	$V_{SS}$	-	0.4	V	
			$V_{CC} < 2.7 V$ , $I_{OL} = 2mA$					
Input leak current	$I_{IL}$	-	-	-5	-	+5	$\mu A$	
Pull-up resistor value	$R_{PU}$	Pull-up pin	$V_{CC} \geq 2.7 V$	21	33	66	k $\Omega$	
			$V_{CC} < 2.7 V$	-	-	134		
Input capacitance	$C_{IN}$	Other than VCC, VSS, AVCC, AVSS, AVRH	-	-	5	15	pF	



#### 4. AC Characteristics

##### (1) Main Clock Input Characteristics

( $V_{CC} = 1.65V$  to  $3.6V$ ,  $V_{SS} = 0V$ ,  $T_a = -40^{\circ}C$  to  $+85^{\circ}C$ )

Parameter	Symbol	Pin name	Conditions	Value		Unit	Remarks
				Min	Max		
Input frequency	$F_{CH}$	X0, X1	$V_{CC} \geq 2.7V$	4	48	MHz	When crystal oscillator is connected
			$V_{CC} < 2.7V$	4	20		
-	4		48	MHz	When using external clock		
Input clock cycle	$t_{CYLH}$		-			20.83	250
Input clock pulse width	-		$P_{WH}/t_{CYLH}$ , $P_{WL}/t_{CYLH}$	45	55	%	When using external clock
Input clock rising time and falling time	$t_{CF}$ , $t_{CR}$		-	-	5	ns	When using external clock
Internal operating clock*1 frequency	$F_{CM}$	-	-	-	40	MHz	Master clock
	$F_{CC}$	-	-	-	40	MHz	Base clock (HCLK/FCLK)
	$F_{CP0}$	-	-	-	40	MHz	APB0 bus clock*2
	$F_{CP1}$	-	-	-	40	MHz	APB1 bus clock*2
	$F_{CP2}$	-	-	-	40	MHz	APB2 bus clock*2
Internal operating clock*1 cycle time	$t_{CYCC}$	-	-	25	-	ns	Base clock (HCLK/FCLK)
	$t_{CYCP0}$	-	-	25	-	ns	APB0 bus clock*2
	$t_{CYCP1}$	-	-	25	-	ns	APB1 bus clock*2
	$t_{CYCP2}$	-	-	25	-	ns	APB2 bus clock*2

\*1: For more information about each internal operating clock, see "Chapter: Clock" in "FM3 Family PERIPHERAL MANUAL".

\*2: For about each APB bus which each peripheral is connected to, see "■ BLOCK DIAGRAM" in this data sheet.

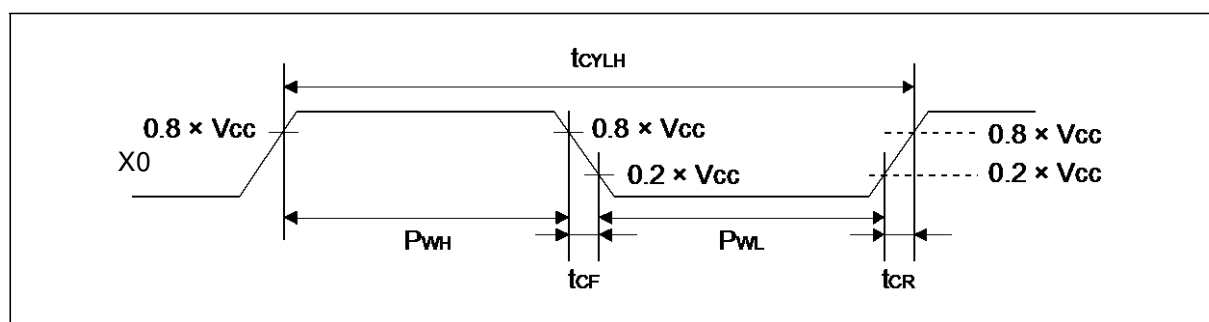

(2) Sub Clock Input Characteristics

( $V_{CC} = 1.65V$  to  $3.6V$ ,  $V_{SS} = 0V$ ,  $T_a = -40^{\circ}C$  to  $+85^{\circ}C$ )

Parameter	Symbol	Pin name	Conditions	Value			Unit	Remarks
				Min	Typ	Max		
Input frequency	$F_{CL}$	X0A, X1A	-	-	32.768	-	kHz	When crystal oscillator is connected*
			-	32	-	100		kHz
Input clock cycle	$t_{CYLL}$		-	10	-	31.25	$\mu s$	When using external clock
Input clock pulse width	-		$P_{WH}/t_{CYLL}$ , $P_{WL}/t_{CYLL}$	45	-	55	%	When using external clock

\*: For more information about crystal oscillator, see "●Sub crystal oscillator" in "■HANDLING DEVICES".

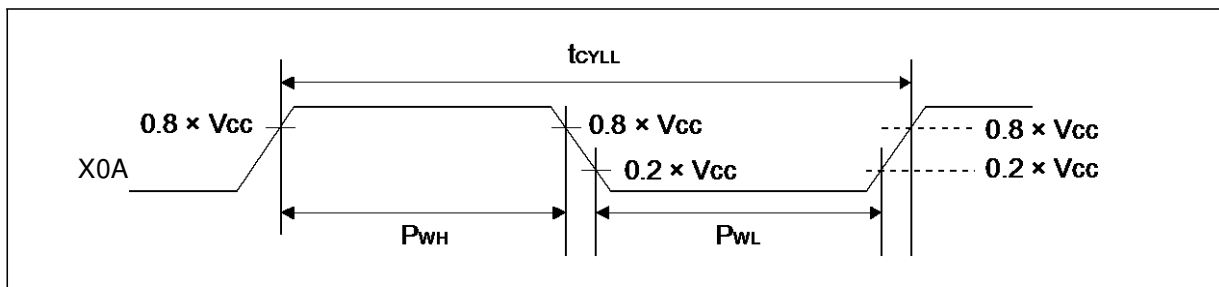

(3) Built-in CR Oscillation Characteristics

- Built-in high-speed CR

( $V_{CC} = 1.65V$  to  $3.6V$ ,  $V_{SS} = 0V$ ,  $T_a = -40^{\circ}C$  to  $+85^{\circ}C$ )

Parameter	Symbol	Conditions	Value			Unit	Remarks
			Min	Typ	Max		
Clock frequency	$F_{CRH}$	$T_a = +25^{\circ}C$ , $V_{CC} \geq 2.7V$	3.94	4	4.06	MHz	When trimming* <sup>1</sup>
		$T_a = -20^{\circ}C$ to $+85^{\circ}C$ , $V_{CC} \geq 2.7V$	3.92	4	4.08		
		$T_a = -40^{\circ}C$ to $+85^{\circ}C$ , $V_{CC} \geq 2.7V$	3.88	4	4.12		
		$T_a = +25^{\circ}C$ , $V_{CC} < 2.7V$	3.9	4	4.1		
		$T_a = -40^{\circ}C$ to $+85^{\circ}C$ , $V_{CC} < 2.7V$	3.66	4	4.20		
		$T_a = -40^{\circ}C$ to $+85^{\circ}C$	2.8	4	5.2	When not trimming	
Frequency stabilization time	$t_{CRWT}$	-	-	-	30	$\mu s$	* <sup>2</sup>

\*1: In the case of using the values in CR trimming area of Flash memory at shipment for frequency/temperature trimming.

\*2: This is the time to stabilize the frequency of high-speed CR clock after setting trimming value. This period is able to use high-speed CR clock as source clock.

- Built-in low-speed CR

( $V_{CC} = 1.65V$  to  $3.6V$ ,  $V_{SS} = 0V$ ,  $T_a = -40^{\circ}C$  to  $+85^{\circ}C$ )

Parameter	Symbol	Conditions	Value			Unit	Remarks
			Min	Typ	Max		
Clock frequency	$F_{CRL}$	-	50	100	150	kHz	

(4-1) Operating Conditions of Main PLL (In the case of using main clock for input of PLL)

( $V_{CC} = 1.65V$  to  $3.6V$ ,  $V_{SS} = 0V$ ,  $T_a = -40^{\circ}C$  to  $+85^{\circ}C$ )

Parameter	Symbol	Value			Unit	Remarks
		Min	Typ	Max		
PLL oscillation stabilization wait time* <sup>1</sup> (LOCK UP time)	$t_{LOCK}$	100	-	-	$\mu s$	
PLL input clock frequency	$F_{PLL1}$	4	-	16	MHz	
PLL multiplication rate	-	5	-	37	multiplier	
PLL macro oscillation clock frequency	$F_{PLLO}$	75	-	150	MHz	
Main PLL clock frequency* <sup>2</sup>	$F_{CLKPLL}$	-	-	40	MHz	

\*1: Time from when the PLL starts operating until the oscillation stabilizes.

\*2: For more information about Main PLL clock (CLKPLL), see "Chapter: Clock" in "FM3 Family PERIPHERAL MANUAL".

(4-2) Operating Conditions of Main PLL (In the case of using the built-in high-speed CR for input clock of main PLL)

( $V_{CC} = 1.65V$  to  $3.6V$ ,  $V_{SS} = 0V$ ,  $T_a = -40^{\circ}C$  to  $+85^{\circ}C$ )

Parameter	Symbol	Value			Unit	Remarks
		Min	Typ	Max		
PLL oscillation stabilization wait time* <sup>1</sup> (LOCK UP time)	$t_{LOCK}$	100	-	-	$\mu s$	
PLL input clock frequency	$F_{PLL1}$	3.8	4	4.2	MHz	
PLL multiplication rate	-	19	-	35	multiplier	
PLL macro oscillation clock frequency	$F_{PLLO}$	72	-	150	MHz	
Main PLL clock frequency* <sup>2</sup>	$F_{CLKPLL}$	-	-	40	MHz	

\*1: Time from when the PLL starts operating until the oscillation stabilizes.

\*2: For more information about Main PLL clock (CLKPLL), see "Chapter: Clock" in "FM3 Family PERIPHERAL MANUAL".

Note: Make sure to input to the main PLL source clock, the high-speed CR clock (CLKHC) that the frequency has been trimmed.

(5) Reset Input Characteristics

( $V_{CC} = 1.65V$  to  $3.6V$ ,  $V_{SS} = 0V$ ,  $T_a = -40^{\circ}C$  to  $+85^{\circ}C$ )

Parameter	Symbol	Pin name	Conditions	Value		Unit	Remarks
				Min	Max		
Reset input time	$t_{INITX}$	INITX	-	500	-	ns	

(6) Power-on Reset Timing

( $V_{CC} = 1.65V$  to  $3.6V$ ,  $V_{SS} = 0V$ ,  $T_a = -40^{\circ}C$  to  $+85^{\circ}C$ )

Parameter	Symbol	Pin name	Value		Unit	Remarks
			Min	Max		
Power supply rising time	$T_r$	VCC	0	-	ms	
Power supply shut down time	$T_{off}$		1	-	ms	

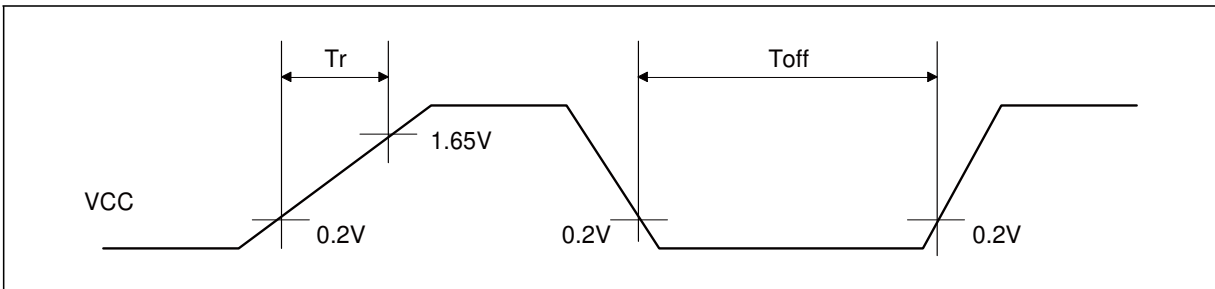

(7) External Bus Timing

- External bus clock output characteristics

( $V_{CC} = 1.65V$  to  $3.6V$ ,  $V_{SS} = 0V$ ,  $T_a = -40^{\circ}C$  to  $+85^{\circ}C$ )

Parameter	Symbol	Pin name	Conditions	Value		Unit
				Min	Max	
Output frequency	$t_{CYCLE}$	MCLKOUT*	$V_{CC} \geq 2.7V$	-	40	MHz
			$V_{CC} < 2.7V$	-	20	MHz

\*: The external bus clock (MCLKOUT) is a divided clock of HCLK.

For more information about setting of clock divider, see "Chapter: External Bus Interface" in "FM3 Family PERIPHERAL MANUAL".

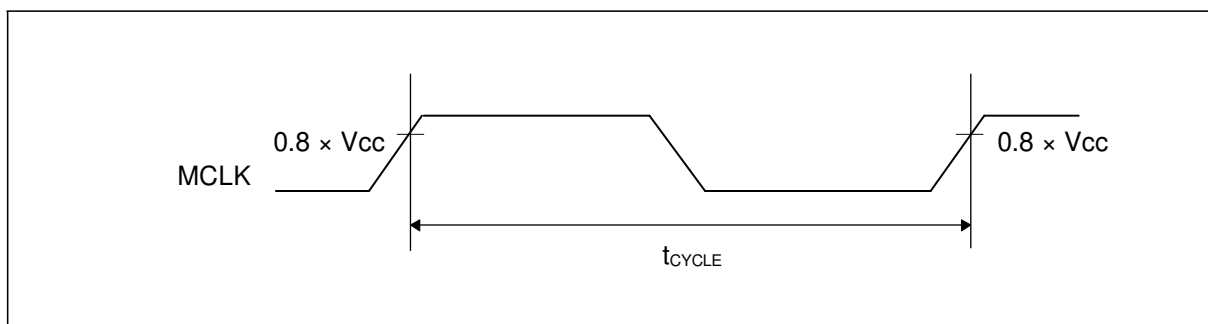

- External bus signal input/output characteristics

( $V_{CC} = 1.65V$  to  $3.6V$ ,  $V_{SS} = 0V$ ,  $T_a = -40^{\circ}C$  to  $+85^{\circ}C$ )

Parameter	Symbol	Conditions	Value	Unit	Remarks
Signal input characteristics	$V_{IH}$	-	$0.8 \times V_{CC}$	V	
	$V_{IL}$		$0.2 \times V_{CC}$	V	
Signal output characteristics	$V_{OH}$	-	$0.8 \times V_{CC}$	V	
	$V_{OL}$		$0.2 \times V_{CC}$	V	

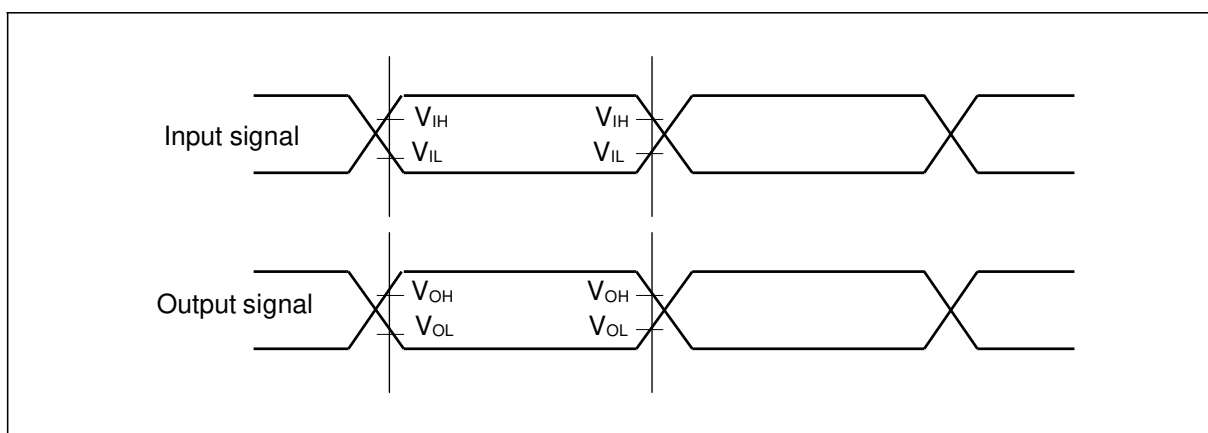

• Separate Bus Access Asynchronous SRAM Mode

( $V_{CC} = 1.65V$  to  $3.6V$ ,  $V_{SS} = 0V$ ,  $T_a = -40^{\circ}C$  to  $+85^{\circ}C$ )

Parameter	Symbol	Pin name	Conditions	Value		Unit
				Min	Max	
MOEX Min pulse width	$t_{OE\bar{W}}$	MOEX	$V_{CC} \geq 2.7V$ $V_{CC} < 2.7V$	MCLK $\times$ n-3	-	ns
MCSX $\downarrow \rightarrow$ Address output delay time	$t_{CSL-AV}$	MCSX[7:0], MAD[24:0]	$V_{CC} \geq 2.7V$ $V_{CC} < 2.7V$	-9 -12	+9 +12	ns
MOEX $\uparrow \rightarrow$ Address hold time	$t_{OE\bar{H}-AX}$	MOEX, MAD[24:0]	$V_{CC} \geq 2.7V$ $V_{CC} < 2.7V$	0	MCLK $\times$ m+9 MCLK $\times$ m+12	ns
MCSX $\downarrow \rightarrow$ MOEX $\downarrow$ delay time	$t_{CSL-OEL}$	MOEX, MCSX[7:0]	$V_{CC} \geq 2.7V$ $V_{CC} < 2.7V$	MCLK $\times$ m-9 MCLK $\times$ m-12	MCLK $\times$ m+9 MCLK $\times$ m+12	ns
MOEX $\uparrow \rightarrow$ MCSX $\uparrow$ time	$t_{OE\bar{H}-CSH}$		$V_{CC} \geq 2.7V$ $V_{CC} < 2.7V$	0	MCLK $\times$ m+9 MCLK $\times$ m+12	ns
MCSX $\downarrow \rightarrow$ MDQM $\downarrow$ delay time	$t_{CSL-RDQML}$	MCSX, MDQM[1:0]	$V_{CC} \geq 2.7V$ $V_{CC} < 2.7V$	MCLK $\times$ m-9 MCLK $\times$ m-12	MCLK $\times$ m+9 MCLK $\times$ m+12	ns
Data set up $\rightarrow$ MOEX $\uparrow$ time	$t_{DS-OE}$	MOEX, MADATA[15:0]	$V_{CC} \geq 2.7V$ $V_{CC} < 2.7V$	20 38	- -	ns
MOEX $\uparrow \rightarrow$ Data hold time	$t_{DH-OE}$	MOEX, MADATA[15:0]	$V_{CC} \geq 2.7V$ $V_{CC} < 2.7V$	0	-	ns
MWEX Min pulse width	$t_{WE\bar{W}}$	MWEX	$V_{CC} \geq 2.7V$ $V_{CC} < 2.7V$	MCLK $\times$ n-3	-	ns
MWEX $\uparrow \rightarrow$ Address output delay time	$t_{WE\bar{H}-AX}$	MWEX, MAD[24:0]	$V_{CC} \geq 2.7V$ $V_{CC} < 2.7V$	0	MCLK $\times$ m+9 MCLK $\times$ m+12	ns
MCSX $\downarrow \rightarrow$ MWEX $\downarrow$ delay time	$t_{CSL-WEL}$	MWEX, MCSX[7:0]	$V_{CC} \geq 2.7V$ $V_{CC} < 2.7V$	MCLK $\times$ n-9 MCLK $\times$ n-12	MCLK $\times$ n+9 MCLK $\times$ n+12	ns
MWEX $\uparrow \rightarrow$ MCSX $\uparrow$ delay time	$t_{WE\bar{H}-CSH}$		$V_{CC} \geq 2.7V$ $V_{CC} < 2.7V$	0	MCLK $\times$ m+9 MCLK $\times$ m+12	ns
MCSX $\downarrow \rightarrow$ MDQM $\downarrow$ delay time	$t_{CSL-WDQML}$	MCSX, MDQM[1:0]	$V_{CC} \geq 2.7V$ $V_{CC} < 2.7V$	MCLK $\times$ n-9 MCLK $\times$ n-12	MCLK $\times$ n+9 MCLK $\times$ n+12	ns
MCSX $\downarrow \rightarrow$ Data output time	$t_{CSL-DV}$	MCSX, MADATA[15:0]	$V_{CC} \geq 2.7V$ $V_{CC} < 2.7V$	MCLK-9 MCLK-12	MCLK+9 MCLK+12	ns
MWEX $\uparrow \rightarrow$ Data hold time	$t_{WE\bar{H}-DX}$	MWEX, MADATA[15:0]	$V_{CC} \geq 2.7V$ $V_{CC} < 2.7V$	0	MCLK $\times$ m+9 MCLK $\times$ m+12	ns

Note: When the external load capacitance  $C_L = 30pF$  ( $m = 0$  to  $15$ ,  $n = 1$  to  $16$ ).

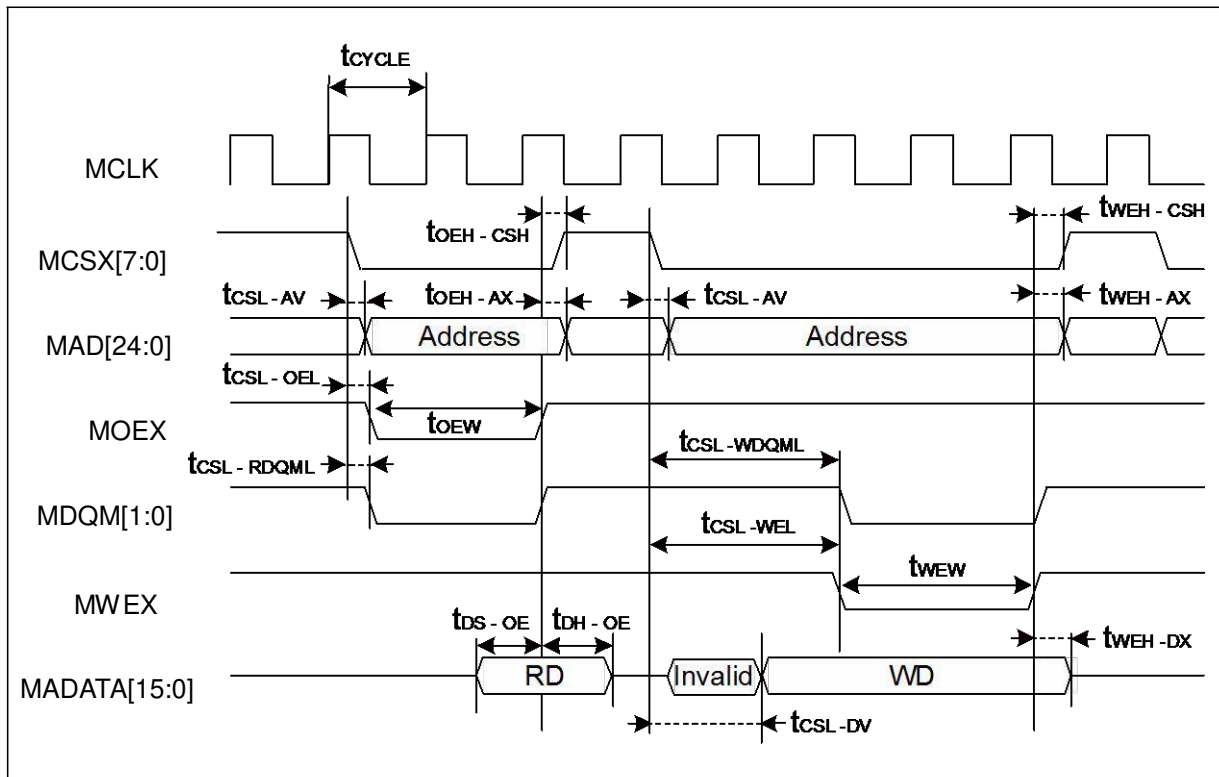

• Separate Bus Access Synchronous SRAM Mode

( $V_{CC} = 1.65V$  to  $3.6V$ ,  $V_{SS} = 0V$ ,  $T_a = -40^{\circ}C$  to  $+85^{\circ}C$ )

Parameter	Symbol	Pin name	Conditions	Value		Unit
				Min	Max	
Address delay time	$t_{AV}$	MCLK, MAD[24:0]	$V_{CC} \geq 2.7V$	1	9	ns
			$V_{CC} < 2.7V$		12	
MCSX delay time	$t_{CSL}$	MCLK, MCSX[7:0]	$V_{CC} \geq 2.7V$	1	9	ns
			$V_{CC} < 2.7V$		12	
	$t_{CSH}$		$V_{CC} \geq 2.7V$	1	9	ns
			$V_{CC} < 2.7V$		12	
MOEX delay time	$t_{REL}$	MCLK, MOEX	$V_{CC} \geq 2.7V$	1	9	ns
			$V_{CC} < 2.7V$		12	
	$t_{REH}$		$V_{CC} \geq 2.7V$	1	9	ns
			$V_{CC} < 2.7V$		12	
Data set up → MCLK ↑ time	$t_{DS}$	MCLK, MADATA[15:0]	$V_{CC} \geq 2.7V$	19	-	ns
$V_{CC} < 2.7V$			37			
MCLK ↑ → Data hold time	$t_{DH}$	MCLK, MADATA[15:0]	$V_{CC} \geq 2.7V$	0	-	ns
$V_{CC} < 2.7V$						
MWEX delay time	$t_{WEL}$	MCLK, MWEX	$V_{CC} \geq 2.7V$	1	9	ns
			$V_{CC} < 2.7V$		12	
	$t_{WEH}$		$V_{CC} \geq 2.7V$	1	9	ns
			$V_{CC} < 2.7V$		12	
MDQM[1:0] delay time	$t_{DQML}$	MCLK, MDQM[1:0]	$V_{CC} \geq 2.7V$	1	9	ns
			$V_{CC} < 2.7V$		12	
	$t_{DQMH}$		$V_{CC} \geq 2.7V$	1	9	ns
			$V_{CC} < 2.7V$		12	
MCLK ↑ → Data output time	$t_{ODS}$	MCLK, MADATA[15:0]	$V_{CC} \geq 2.7V$	MCLK+1	MCLK+18	ns
$V_{CC} < 2.7V$			MCLK+24			
MCLK ↑ → Data hold time	$t_{OD}$	MCLK, MADATA[15:0]	$V_{CC} \geq 2.7V$	1	18	ns
$V_{CC} < 2.7V$			24			

Note: When the external load capacitance  $C_L = 30pF$ .

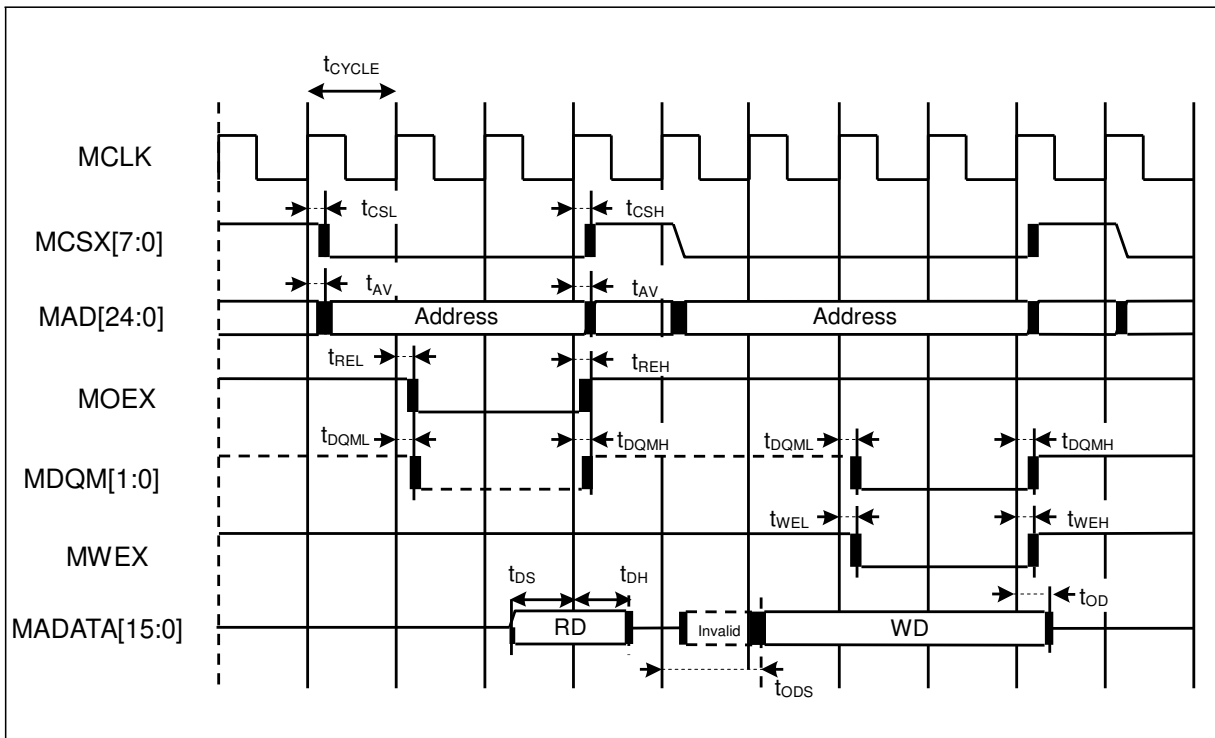



• Multiplexed Bus Access Asynchronous SRAM Mode

( $V_{CC} = 1.65V$  to  $3.6V$ ,  $V_{SS} = 0V$ ,  $T_a = -40^{\circ}C$  to  $+85^{\circ}C$ )

Parameter	Symbol	Pin name	Conditions	Value		Unit
				Min	Max	
Multiplexed address delay time	$t_{ALE-CHMADV}$	MALE, MADATA[15:0]	$V_{CC} \geq 2.7V$	0	+10	ns
			$V_{CC} < 2.7V$		+20	
Multiplexed address hold time	$t_{CHMADH}$	MALE, MADATA[15:0]	$V_{CC} \geq 2.7V$	$MCLK \times n + 0$	$MCLK \times n + 10$	ns
			$V_{CC} < 2.7V$	$MCLK \times n + 0$	$MCLK \times n + 20$	

Note: When the external load capacitance  $C_L = 30pF$  ( $m = 0$  to  $15$ ,  $n = 1$  to  $16$ ).

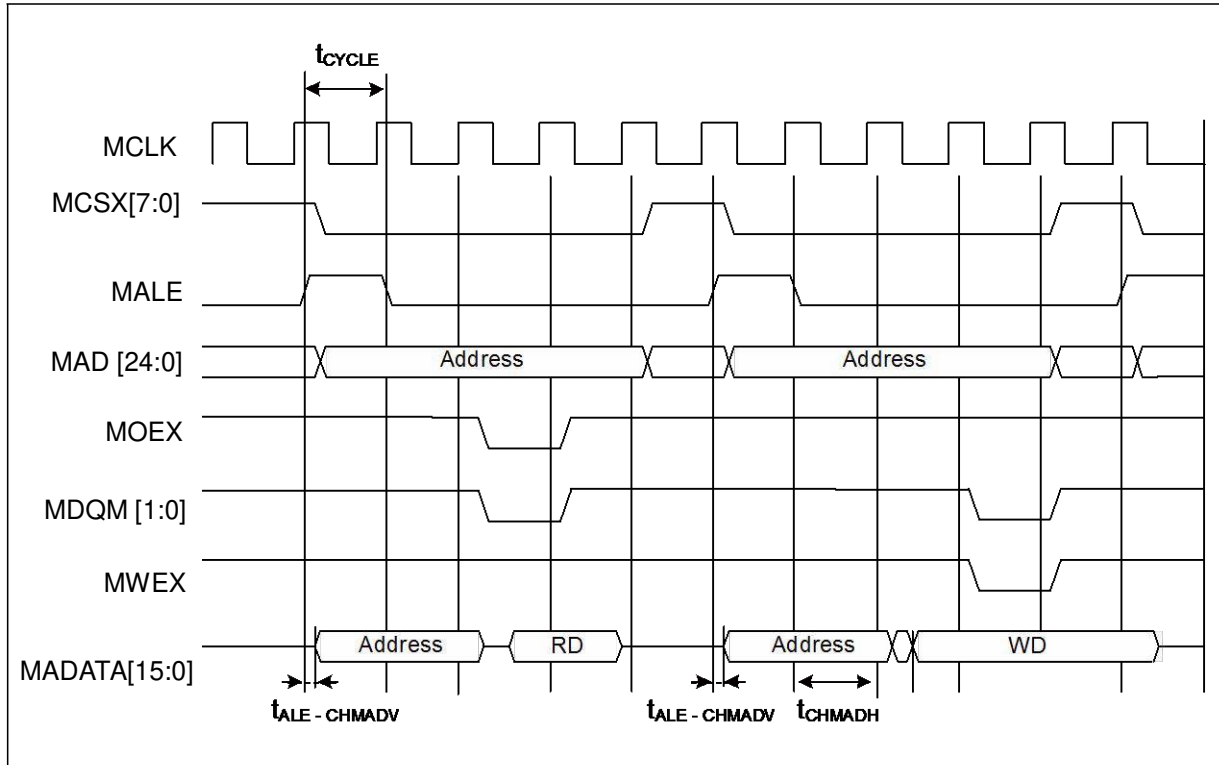

• Multiplexed Bus Access Synchronous SRAM Mode

( $V_{CC} = 1.65V$  to  $3.6V$ ,  $V_{SS} = 0V$ ,  $T_a = -40^{\circ}C$  to  $+85^{\circ}C$ )

Parameter	Symbol	Pin name	Conditions	Value		Unit	Remarks
				Min	Max		
MALE delay time	$t_{CHAL}$	MCLK, ALE	$V_{CC} \geq 2.7V$	1	9	ns	
			$V_{CC} < 2.7V$		12		
	$t_{CHAH}$		$V_{CC} \geq 2.7V$	1	9	ns	
			$V_{CC} < 2.7V$		12		
MCLK $\uparrow \rightarrow$ Multiplexed Address delay time	$t_{CHMADV}$	MCLK, MADATA[15:0]	$V_{CC} \geq 2.7V$	1	$t_{OD}$	ns	
			$V_{CC} < 2.7V$				
MCLK $\uparrow \rightarrow$ Multiplexed Data output time	$t_{CHMADX}$		$V_{CC} \geq 2.7V$	1	$t_{OD}$	ns	
			$V_{CC} < 2.7V$				

Note: When the external load capacitance  $C_L = 30pF$ .

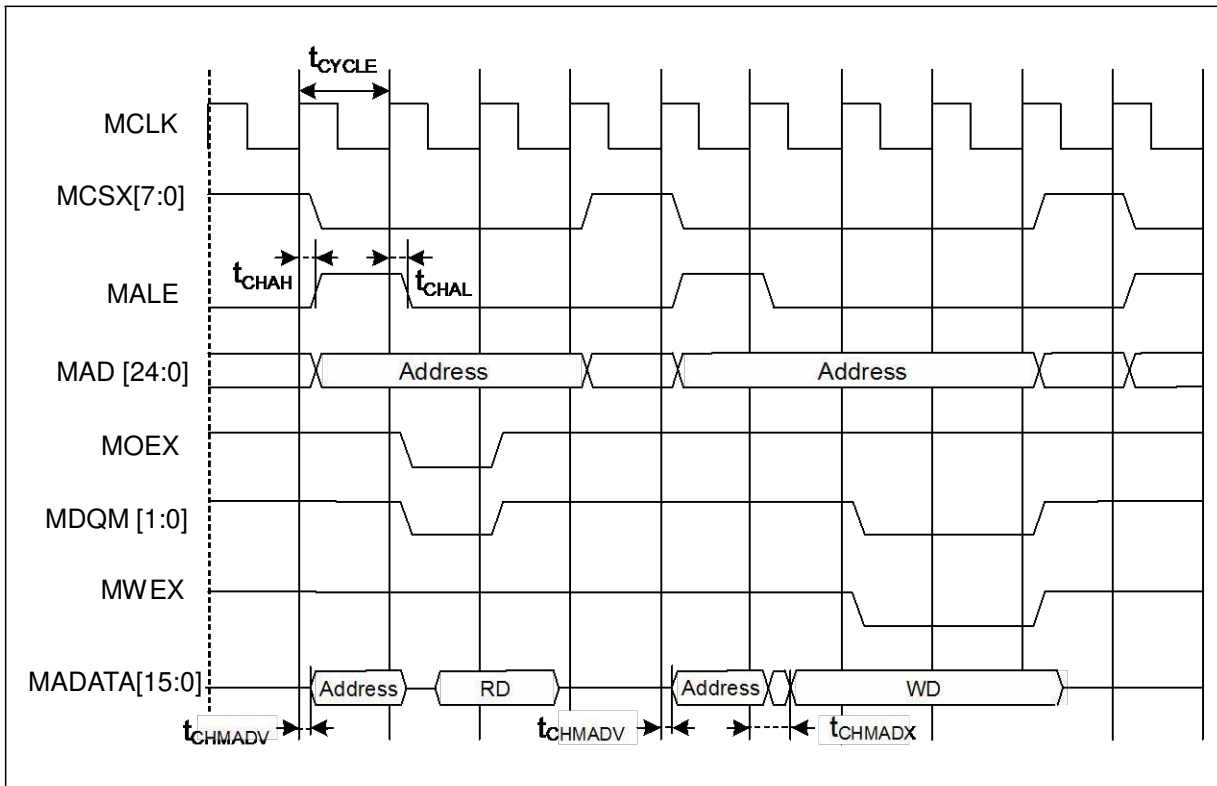

## • NAND Flash Memory Mode

(V<sub>CC</sub> = 1.65V to 3.6V, V<sub>SS</sub> = 0V, Ta = - 40°C to + 85°C)

Parameter	Symbol	Pin name	Conditions	Value		Unit
				Min	Max	
MNREX Min pulse width	t <sub>NREW</sub>	MNREX	V <sub>CC</sub> ≥ 2.7V V <sub>CC</sub> < 2.7V	MCLK×n-3	-	ns
Data setup → MNREX↑time	t <sub>DS-NRE</sub>	MNREX, MADATA[15:0]	V <sub>CC</sub> ≥ 2.7V V <sub>CC</sub> < 2.7V	20 38	- -	ns
MNREX↑→ Data hold time	t <sub>DH-NRE</sub>	MNREX, MADATA[15:0]	V <sub>CC</sub> ≥ 2.7V V <sub>CC</sub> < 2.7V	0	-	ns
MNALE↑→ MNWEX delay time	t <sub>ALEH-NWEL</sub>	MNALE, MNWEX	V <sub>CC</sub> ≥ 2.7V V <sub>CC</sub> < 2.7V	MCLK×m-9 MCLK×m-12	MCLK×m+9 MCLK×m+12	ns
MNALE↓→ MNWEX delay time	t <sub>ALEL-NWEL</sub>	MNALE, MNWEX	V <sub>CC</sub> ≥ 2.7V V <sub>CC</sub> < 2.7V	MCLK×m-9 MCLK×m-12	MCLK×m+9 MCLK×m+12	ns
MNCLE↑→ MNWEX delay time	t <sub>CLEH-NWEL</sub>	MNCLE, MNWEX	V <sub>CC</sub> ≥ 2.7V V <sub>CC</sub> < 2.7V	MCLK×m-9 MCLK×m-12	MCLK×m+9 MCLK×m+12	ns
MNWEX↑→ MNCLE delay time	t <sub>NWEH-CLEL</sub>	MNCLE, MNWEX	V <sub>CC</sub> ≥ 2.7V V <sub>CC</sub> < 2.7V	0	MCLK×m+9 MCLK×m+12	ns
MNWEX Min pulse width	t <sub>NWEW</sub>	MNWEX	V <sub>CC</sub> ≥ 2.7V V <sub>CC</sub> < 2.7V	MCLK×n-3	-	ns
MNWEX↓→ Data output time	t <sub>NWEL-DV</sub>	MNWEX, MADATA[15:0]	V <sub>CC</sub> ≥ 2.7V V <sub>CC</sub> < 2.7V	- 9 -12	+ 9 +12	ns
MNWEX↑→ Data hold time	t <sub>NWEH-DX</sub>	MNWEX, MADATA[15:0]	V <sub>CC</sub> ≥ 2.7V V <sub>CC</sub> < 2.7V	0	MCLK×m+9 MCLK×m+12	ns

Note: When the external load capacitance C<sub>L</sub> = 30pF (m=0 to 15, n=1 to 16).

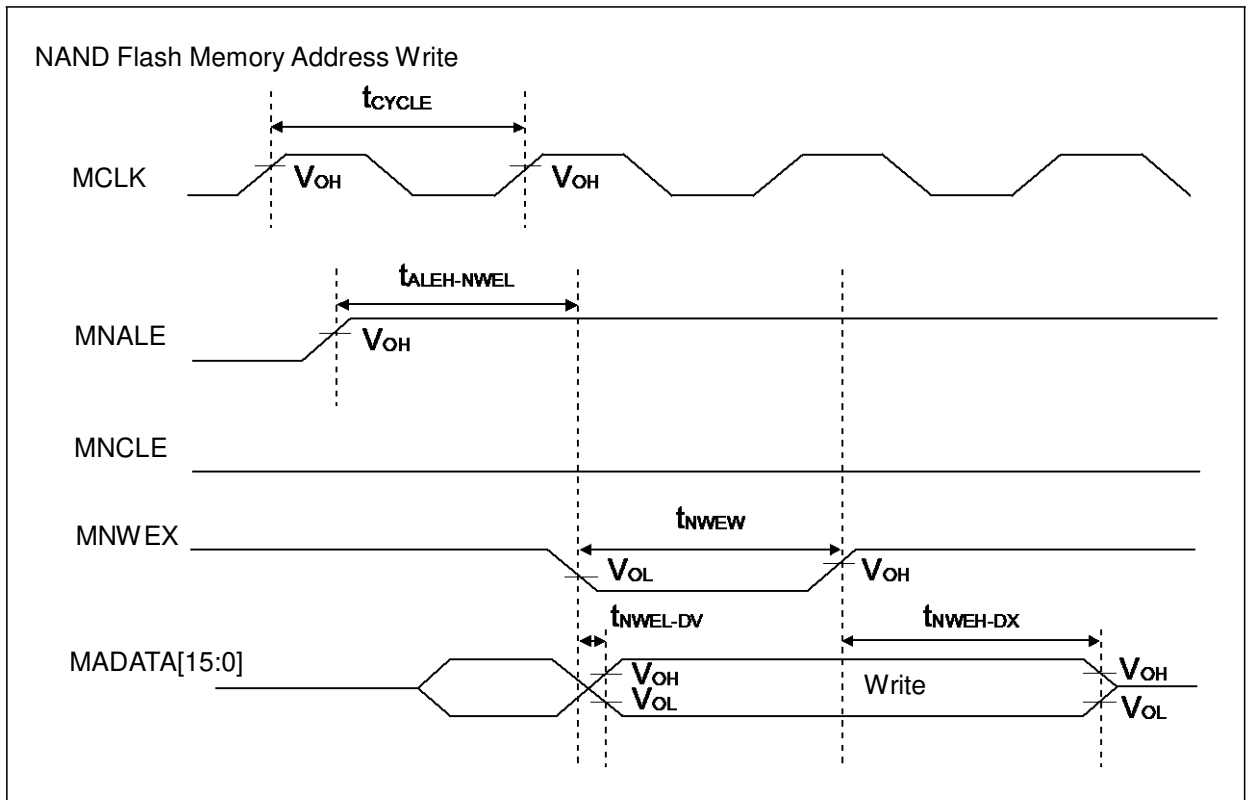
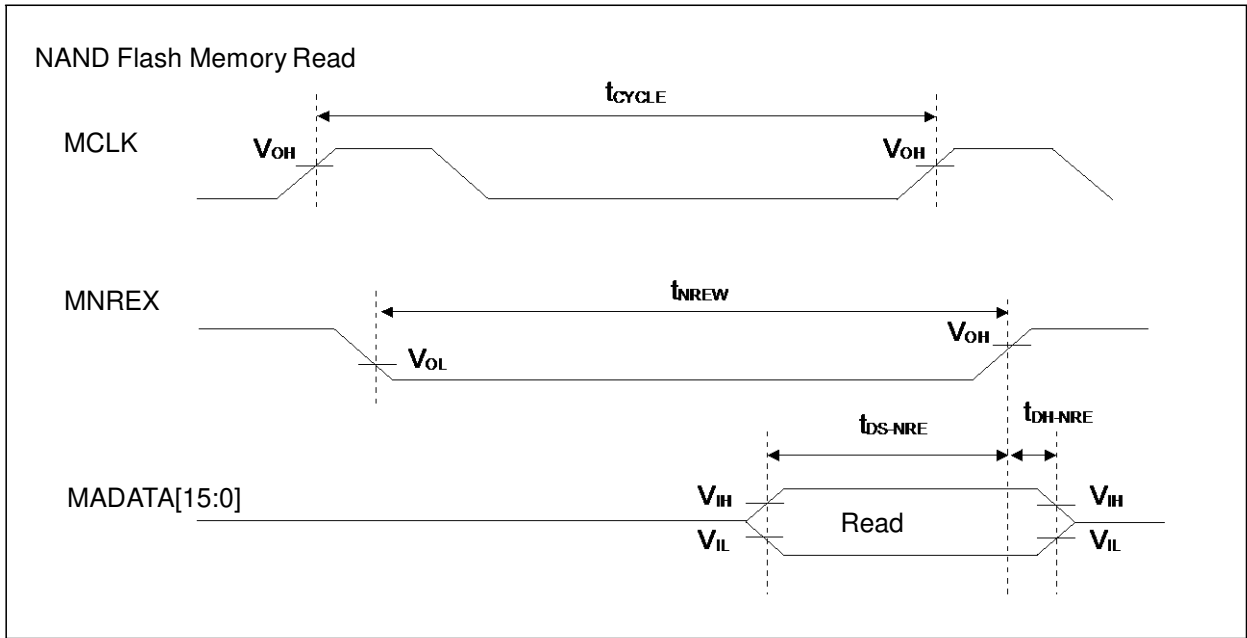

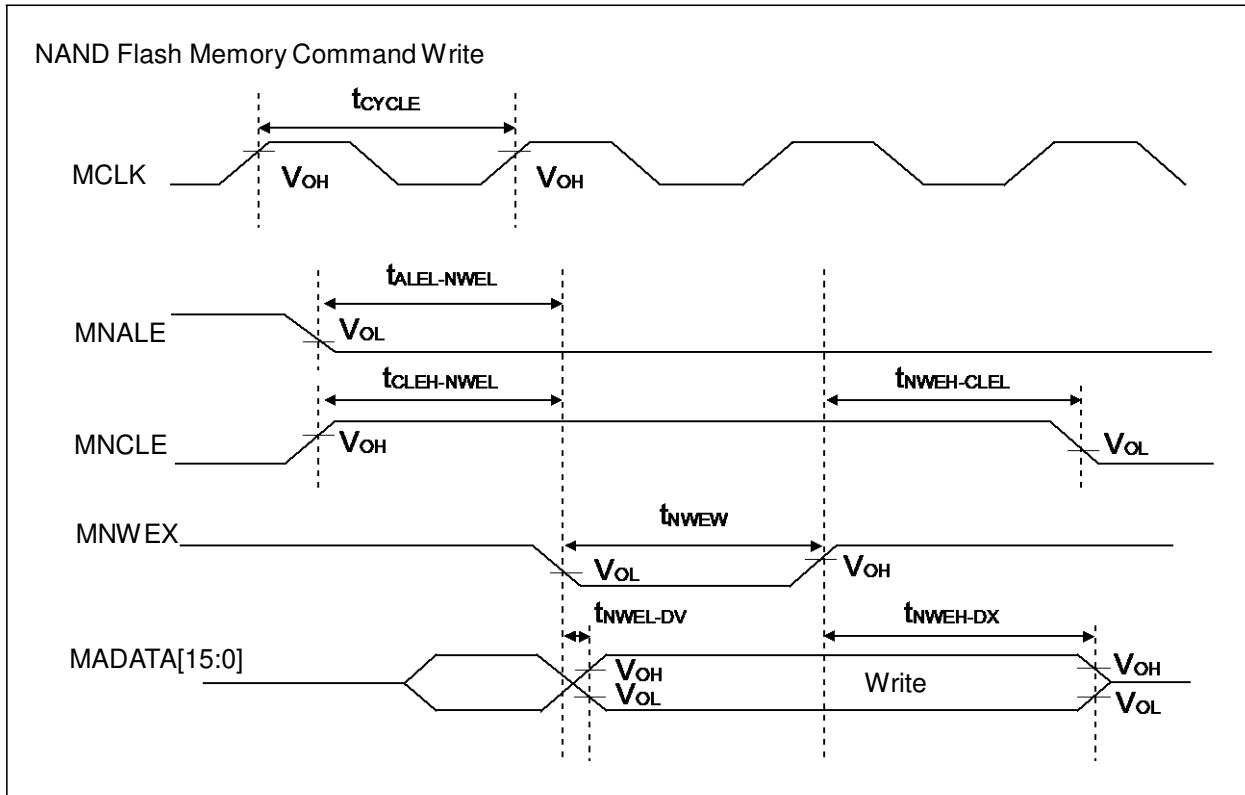

- External Ready Input Timing

( $V_{CC} = 1.65V$  to  $3.6V$ ,  $V_{SS} = 0V$ ,  $T_a = -40^{\circ}C$  to  $+85^{\circ}C$ )

Parameter	Symbol	Pin name	Conditions	Value		Unit	Remarks
				Min	Max		
MCLK $\uparrow$ MRDY input setup time	$t_{RDYI}$	MCLK, MRDY	$V_{CC} \geq 2.7V$	19	-	ns	
			$V_{CC} < 2.7V$	37			

- When RDY is input

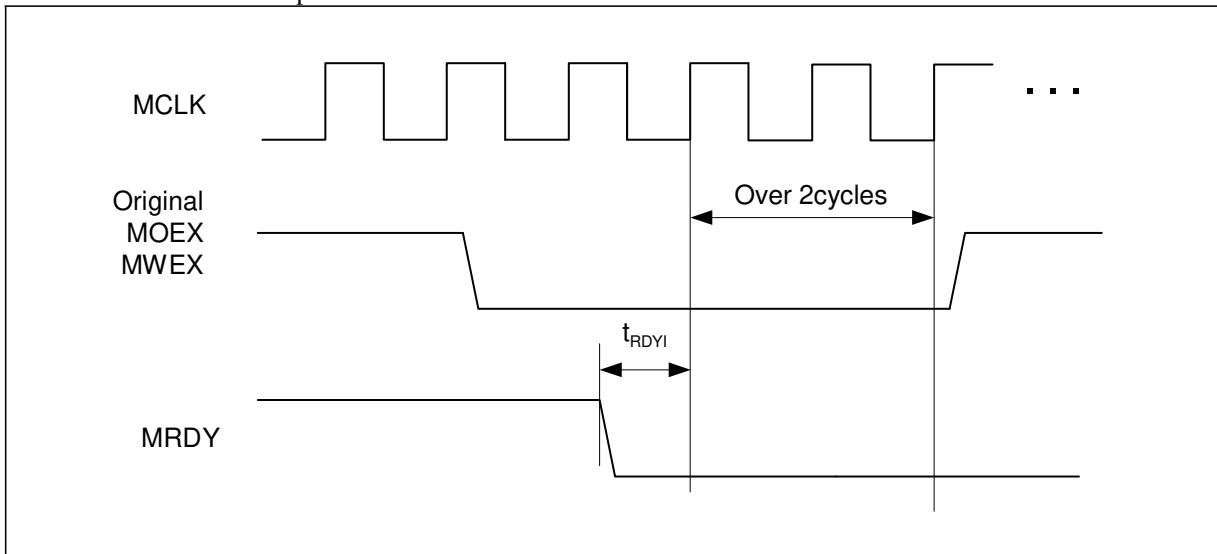

- When RDY is released

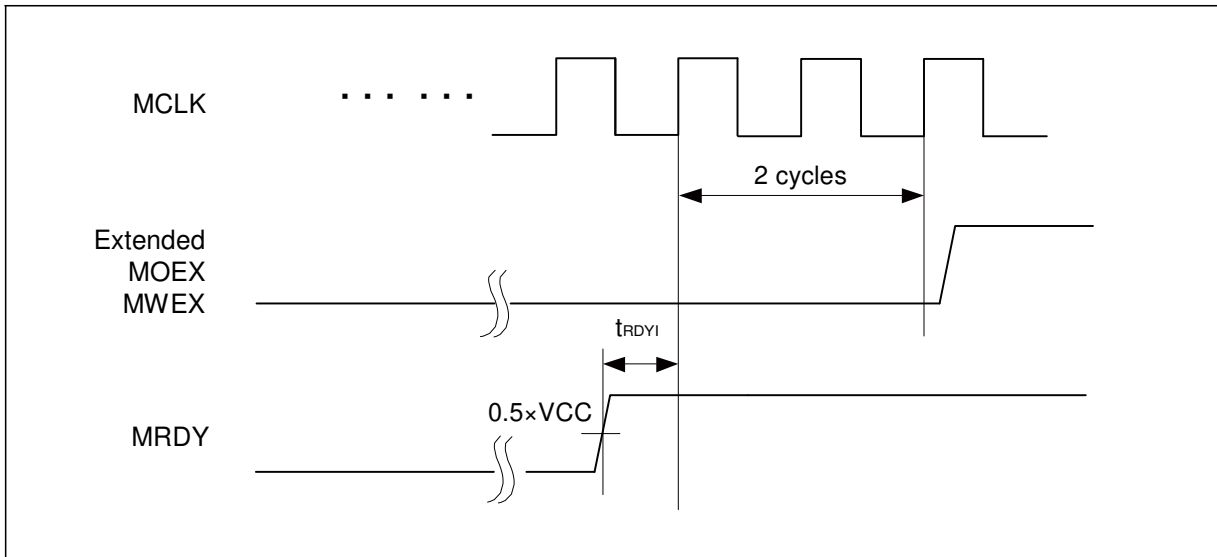

(8) Base Timer Input Timing

- Timer input timing

( $V_{CC} = 1.65V$  to  $3.6V$ ,  $V_{SS} = 0V$ ,  $T_a = -40^{\circ}C$  to  $+85^{\circ}C$ )

Parameter	Symbol	Pin name	Conditions	Value		Unit	Remarks
				Min	Max		
Input pulse width	$t_{TIWH}$ , $t_{TIWL}$	TIOAn/TIOBn (when using as ECK, TIN)	-	$2t_{CYCP}$	-	ns	

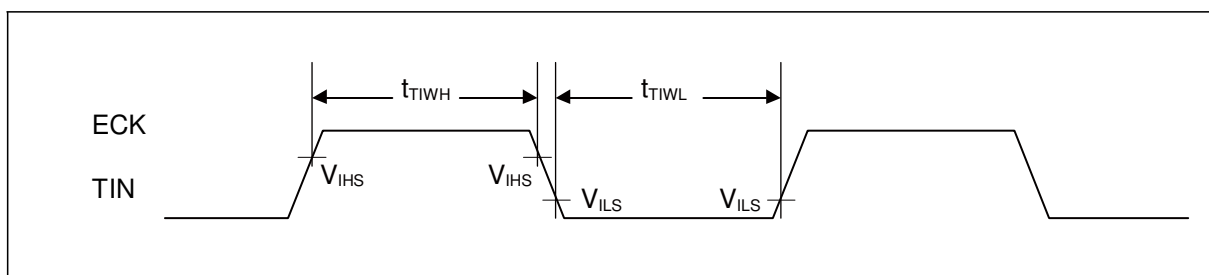

- Trigger input timing

( $V_{CC} = 1.65V$  to  $3.6V$ ,  $V_{SS} = 0V$ ,  $T_a = -40^{\circ}C$  to  $+85^{\circ}C$ )

Parameter	Symbol	Pin name	Conditions	Value		Unit	Remarks
				Min	Max		
Input pulse width	$t_{TRGH}$ , $t_{TRGL}$	TIOAn/TIOBn (when using as TGIN)	-	$2t_{CYCP}$	-	ns	

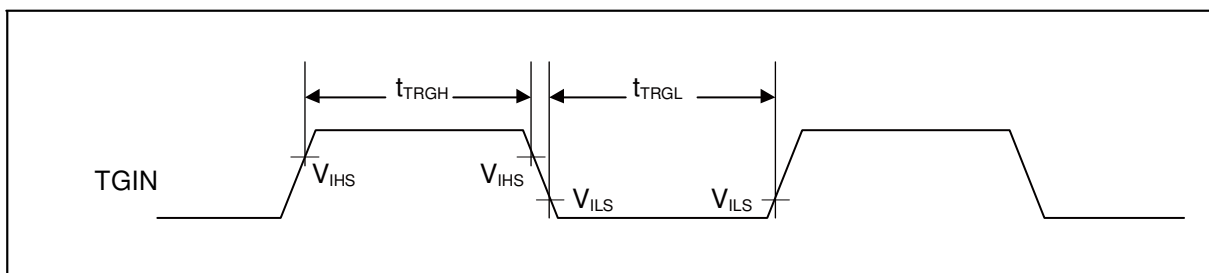

Note:  $t_{CYCP}$  indicates the APB bus cycle time.

About the APB bus number which the Base Timer is connected to, see "■BLOCK DIAGRAM" in this data sheet.

(9) CSIO Timing

- Synchronous serial (SPI = 0, SCINV = 0)

( $V_{CC} = 1.65V$  to  $3.6V$ ,  $V_{SS} = 0V$ ,  $T_a = -40^{\circ}C$  to  $+85^{\circ}C$ )

Parameter	Symbol	Pin name	Conditions	$V_{CC} < 2.7V$		$V_{CC} \geq 2.7V$		Unit
				Min	Max	Min	Max	
Serial clock cycle time	$t_{SCYC}$	SCK <sub>X</sub>	Internal shift clock operation	$4t_{CYCP}$	-	$4t_{CYCP}$	-	ns
SCK ↓ → SOT delay time	$t_{SLOVI}$	SCK <sub>X</sub> , SOT <sub>X</sub>		- 30	+ 30	- 20	+ 20	ns
SIN → SCK ↑ setup time	$t_{IVSHI}$	SCK <sub>X</sub> , SIN <sub>X</sub>		50	-	30	-	ns
SCK ↑ → SIN hold time	$t_{SHIXI}$	SCK <sub>X</sub> , SIN <sub>X</sub>		0	-	0	-	ns
Serial clock "L" pulse width	$t_{SLSH}$	SCK <sub>X</sub>	External shift clock operation	$2t_{CYCP} - 10$	-	$2t_{CYCP} - 10$	-	ns
Serial clock "H" pulse width	$t_{SHSL}$	SCK <sub>X</sub>		$t_{CYCP} + 10$	-	$t_{CYCP} + 10$	-	ns
SCK ↓ → SOT delay time	$t_{SLOVE}$	SCK <sub>X</sub> , SOT <sub>X</sub>		-	50	-	30	ns
SIN → SCK ↑ setup time	$t_{IVSHE}$	SCK <sub>X</sub> , SIN <sub>X</sub>		10	-	10	-	ns
SCK ↑ → SIN hold time	$t_{SHIXE}$	SCK <sub>X</sub> , SIN <sub>X</sub>		20	-	20	-	ns
SCK falling time	tF	SCK <sub>X</sub>		-	5	-	5	ns
SCK rising time	tR	SCK <sub>X</sub>		-	5	-	5	ns

- Notes:
- The above characteristics apply to CLK synchronous mode.
  - $t_{CYCP}$  indicates the APB bus clock cycle time.  
About the APB bus number which Multi-function Serial is connected to, see "■BLOCK DIAGRAM" in this data sheet.
  - These characteristics only guarantee the same relocate port number.  
For example, the combination of SCLK<sub>X\_0</sub> and SOT<sub>X\_1</sub> is not guaranteed.
  - When the external load capacitance  $C_L = 30pF$ .



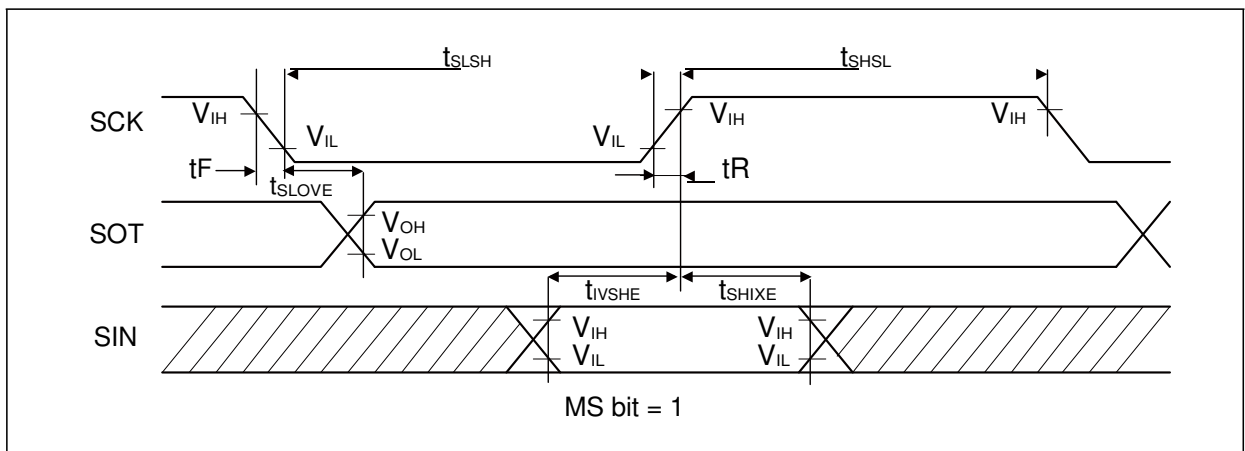
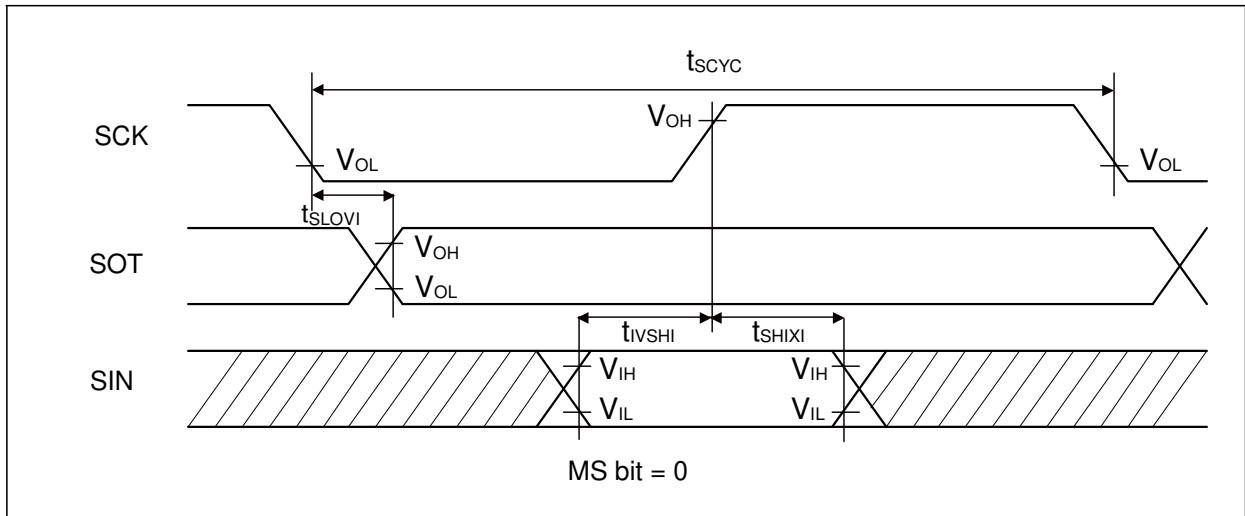

- Synchronous serial (SPI = 0, SCINV = 1)

( $V_{CC} = 1.65V$  to  $3.6V$ ,  $V_{SS} = 0V$ ,  $T_a = -40^{\circ}C$  to  $+85^{\circ}C$ )

Parameter	Symbol	Pin name	Conditions	$V_{CC} < 2.7V$		$V_{CC} \geq 2.7V$		Unit
				Min	Max	Min	Max	
Serial clock cycle time	$t_{SCYC}$	SCK <sub>X</sub>	Internal shift clock operation	$4t_{CYCP}$	-	$4t_{CYCP}$	-	ns
SCK ↑ → SOT delay time	$t_{SHOVI}$	SCK <sub>X</sub> , SOT <sub>X</sub>		- 30	+ 30	- 20	+ 20	ns
SIN → SCK ↓ setup time	$t_{IVSLI}$	SCK <sub>X</sub> , SIN <sub>X</sub>		50	-	30	-	ns
SCK ↓ → SIN hold time	$t_{SLIXI}$	SCK <sub>X</sub> , SIN <sub>X</sub>		0	-	0	-	ns
Serial clock "L" pulse width	$t_{SLSH}$	SCK <sub>X</sub>	External shift clock operation	$2t_{CYCP} - 10$	-	$2t_{CYCP} - 10$	-	ns
Serial clock "H" pulse width	$t_{SHSL}$	SCK <sub>X</sub>		$t_{CYCP} + 10$	-	$t_{CYCP} + 10$	-	ns
SCK ↑ → SOT delay time	$t_{SHOVE}$	SCK <sub>X</sub> , SOT <sub>X</sub>		-	50	-	30	ns
SIN → SCK ↓ setup time	$t_{IVSLE}$	SCK <sub>X</sub> , SIN <sub>X</sub>		10	-	10	-	ns
SCK ↓ → SIN hold time	$t_{SLIXE}$	SCK <sub>X</sub> , SIN <sub>X</sub>		20	-	20	-	ns
SCK falling time	tF	SCK <sub>X</sub>		-	5	-	5	ns
SCK rising time	tR	SCK <sub>X</sub>		-	5	-	5	ns

- Notes:
- The above characteristics apply to CLK synchronous mode.
  - $t_{CYCP}$  indicates the APB bus clock cycle time.  
About the APB bus number which Multi-function Serial is connected to, see "■BLOCK DIAGRAM" in this data sheet.
  - These characteristics only guarantee the same relocate port number.  
For example, the combination of SCLK<sub>X\_0</sub> and SOT<sub>X\_1</sub> is not guaranteed.
  - When the external load capacitance  $C_L = 30pF$ .

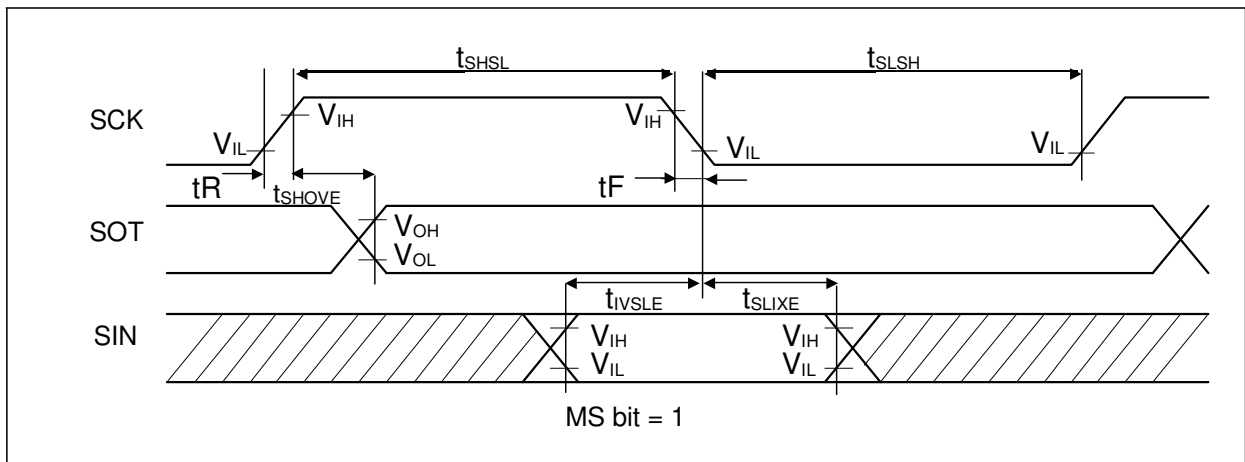
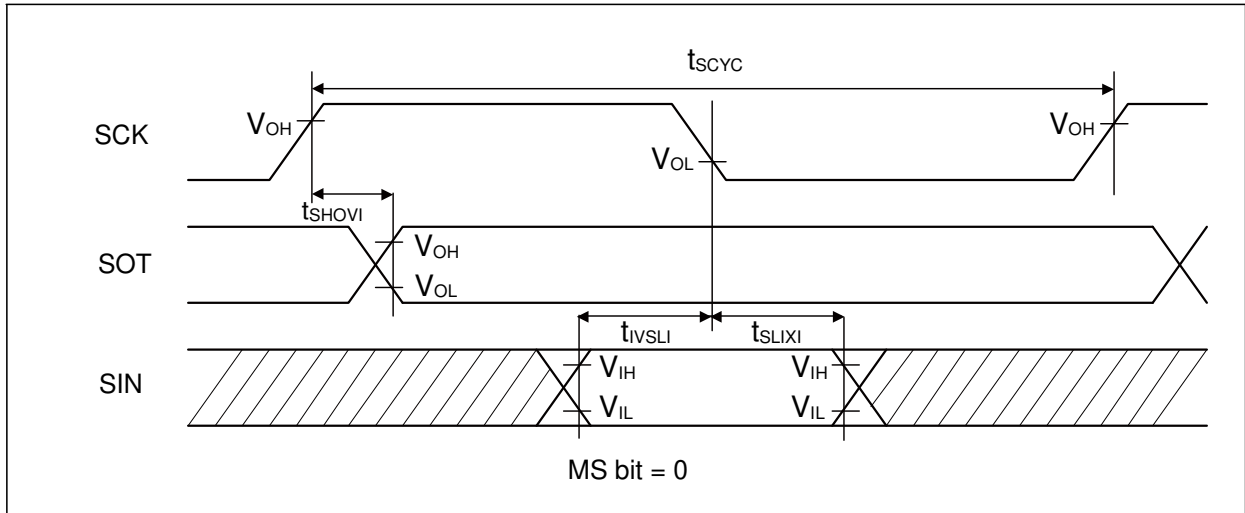

- Synchronous serial (SPI = 1, SCINV = 0)

( $V_{CC} = 1.65V$  to  $3.6V$ ,  $V_{SS} = 0V$ ,  $T_a = -40^{\circ}C$  to  $+85^{\circ}C$ )

Parameter	Symbol	Pin name	Conditions	$V_{CC} < 2.7V$		$V_{CC} \geq 2.7V$		Unit
				Min	Max	Min	Max	
Serial clock cycle time	$t_{SCYC}$	SCK <sub>X</sub>	Internal shift clock operation	$4t_{CYCP}$	-	$4t_{CYCP}$	-	ns
SCK ↑ → SOT delay time	$t_{SHOVI}$	SCK <sub>X</sub> , SOT <sub>X</sub>		- 30	+ 30	- 20	+ 20	ns
SIN → SCK ↓ setup time	$t_{IVSLI}$	SCK <sub>X</sub> , SIN <sub>X</sub>		50	-	30	-	ns
SCK ↓ → SIN hold time	$t_{SLIXI}$	SCK <sub>X</sub> , SIN <sub>X</sub>		0	-	0	-	ns
SOT → SCK ↓ delay time	$t_{SOVLI}$	SCK <sub>X</sub> , SOT <sub>X</sub>		$2t_{CYCP} - 30$	-	$2t_{CYCP} - 30$	-	ns
Serial clock "L" pulse width	$t_{SLSH}$	SCK <sub>X</sub>		$2t_{CYCP} - 10$	-	$2t_{CYCP} - 10$	-	ns
Serial clock "H" pulse width	$t_{SHSL}$	SCK <sub>X</sub>	$t_{CYCP} + 10$	-	$t_{CYCP} + 10$	-	ns	
SCK ↑ → SOT delay time	$t_{SHOVE}$	SCK <sub>X</sub> , SOT <sub>X</sub>	External shift clock operation	-	50	-	30	ns
SIN → SCK ↓ setup time	$t_{IVSLE}$	SCK <sub>X</sub> , SIN <sub>X</sub>		10	-	10	-	ns
SCK ↓ → SIN hold time	$t_{SLIXE}$	SCK <sub>X</sub> , SIN <sub>X</sub>		20	-	20	-	ns
SCK falling time	tF	SCK <sub>X</sub>		-	5	-	5	ns
SCK rising time	tR	SCK <sub>X</sub>		-	5	-	5	ns

- Notes:
- The above characteristics apply to CLK synchronous mode.
  - $t_{CYCP}$  indicates the APB bus clock cycle time.  
About the APB bus number which Multi-function Serial is connected to, see "■BLOCK DIAGRAM" in this data sheet.
  - These characteristics only guarantee the same relocate port number.  
For example, the combination of SCLK<sub>X\_0</sub> and SOT<sub>X\_1</sub> is not guaranteed.
  - When the external load capacitance  $C_L = 30pF$ .

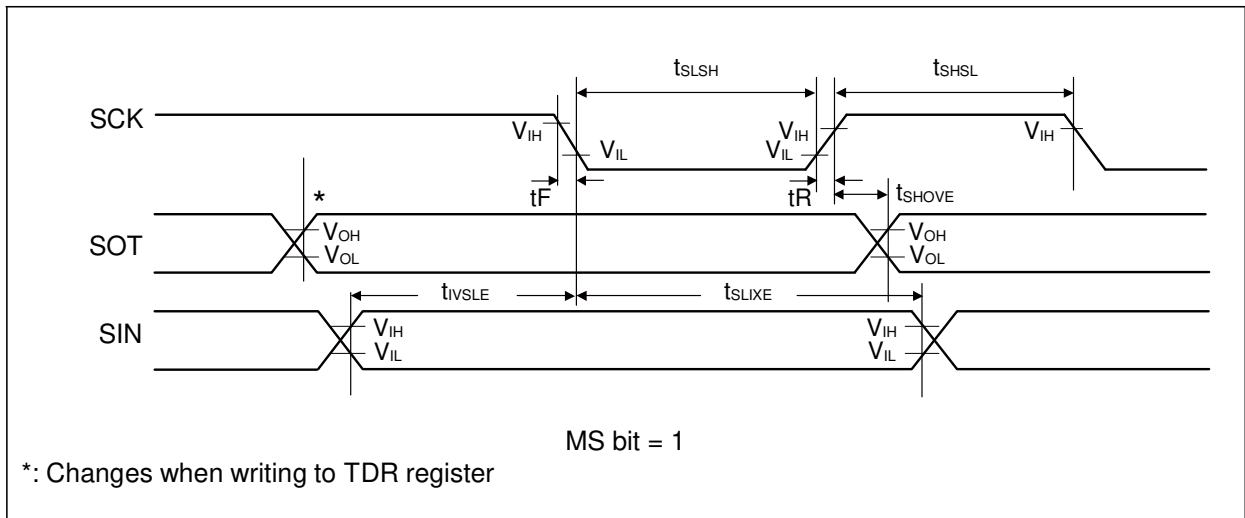
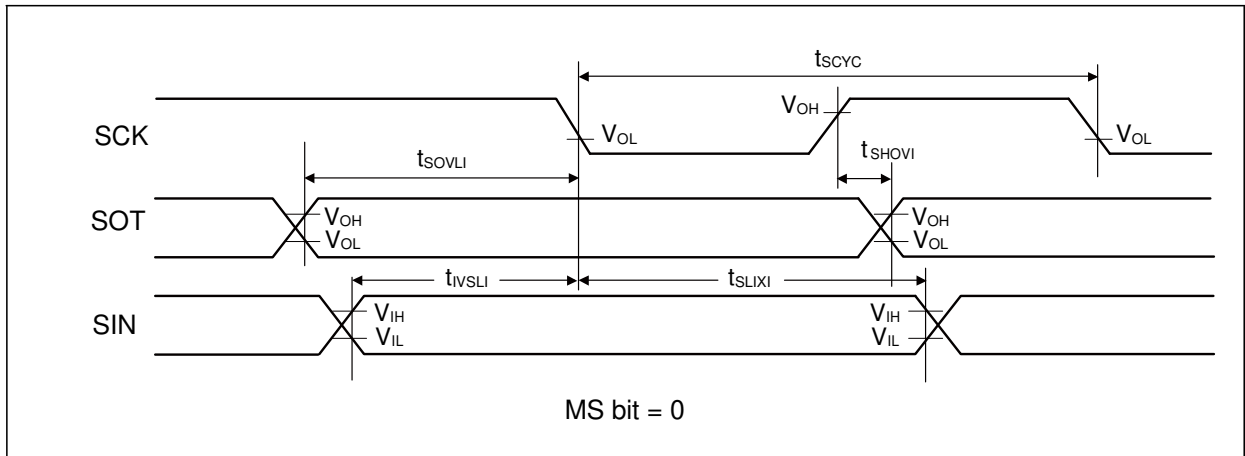

- Synchronous serial (SPI = 1, SCINV = 1)

( $V_{CC} = 1.65V$  to  $3.6V$ ,  $V_{SS} = 0V$ ,  $T_a = -40^{\circ}C$  to  $+85^{\circ}C$ )

Parameter	Symbol	Pin name	Conditions	$V_{CC} < 2.7V$		$V_{CC} \geq 2.7V$		Unit
				Min	Max	Min	Max	
Serial clock cycle time	$t_{SCYC}$	SCK <sub>X</sub>	Internal shift clock operation	$4t_{CYCP}$	-	$4t_{CYCP}$	-	ns
SCK ↓ → SOT delay time	$t_{SLOVI}$	SCK <sub>X</sub> , SOT <sub>X</sub>		- 30	+ 30	- 20	+ 20	ns
SIN → SCK ↑ setup time	$t_{IVSHI}$	SCK <sub>X</sub> , SIN <sub>X</sub>		50	-	30	-	ns
SCK ↑ → SIN hold time	$t_{SHIXI}$	SCK <sub>X</sub> , SIN <sub>X</sub>		0	-	0	-	ns
SOT → SCK ↑ delay time	$t_{SOVHI}$	SCK <sub>X</sub> , SOT <sub>X</sub>		$2t_{CYCP} - 30$	-	$2t_{CYCP} - 30$	-	ns
Serial clock "L" pulse width	$t_{SLSH}$	SCK <sub>X</sub>	External shift clock operation	$2t_{CYCP} - 10$	-	$2t_{CYCP} - 10$	-	ns
Serial clock "H" pulse width	$t_{SHSL}$	SCK <sub>X</sub>		$t_{CYCP} + 10$	-	$t_{CYCP} + 10$	-	ns
SCK ↓ → SOT delay time	$t_{SLOVE}$	SCK <sub>X</sub> , SOT <sub>X</sub>		-	50	-	30	ns
SIN → SCK ↑ setup time	$t_{IVSHE}$	SCK <sub>X</sub> , SIN <sub>X</sub>		10	-	10	-	ns
SCK ↑ → SIN hold time	$t_{SHIXE}$	SCK <sub>X</sub> , SIN <sub>X</sub>		20	-	20	-	ns
SCK falling time	tF	SCK <sub>X</sub>		-	5	-	5	ns
SCK rising time	tR	SCK <sub>X</sub>		-	5	-	5	ns

- Notes:
- The above characteristics apply to CLK synchronous mode.
  - $t_{CYCP}$  indicates the APB bus clock cycle time.  
About the APB bus number which Multi-function Serial is connected to, see "■BLOCK DIAGRAM" in this data sheet.
  - These characteristics only guarantee the same relocate port number.  
For example, the combination of SCLK<sub>X\_0</sub> and SOT<sub>X\_1</sub> is not guaranteed.
  - When the external load capacitance  $C_L = 30pF$ .

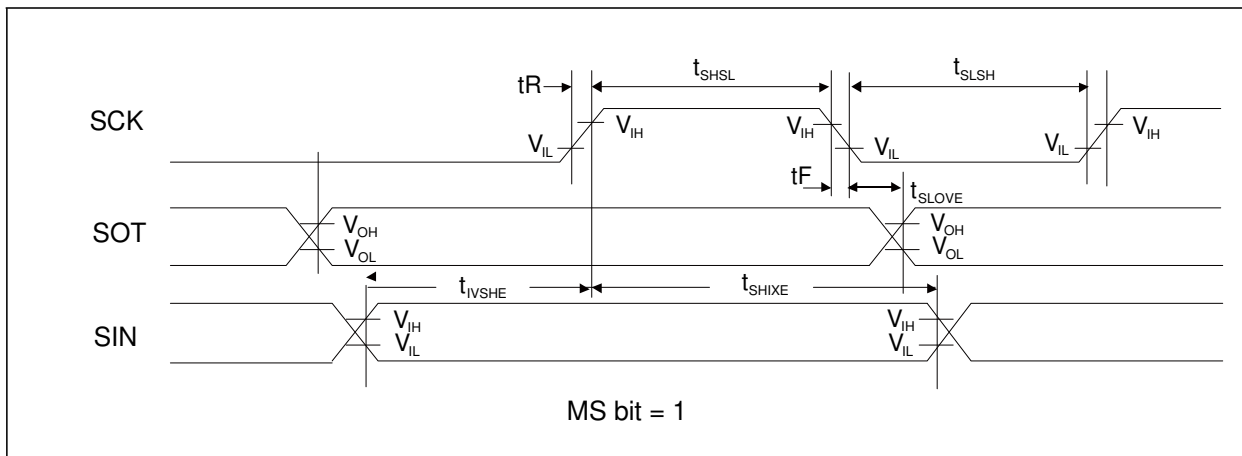
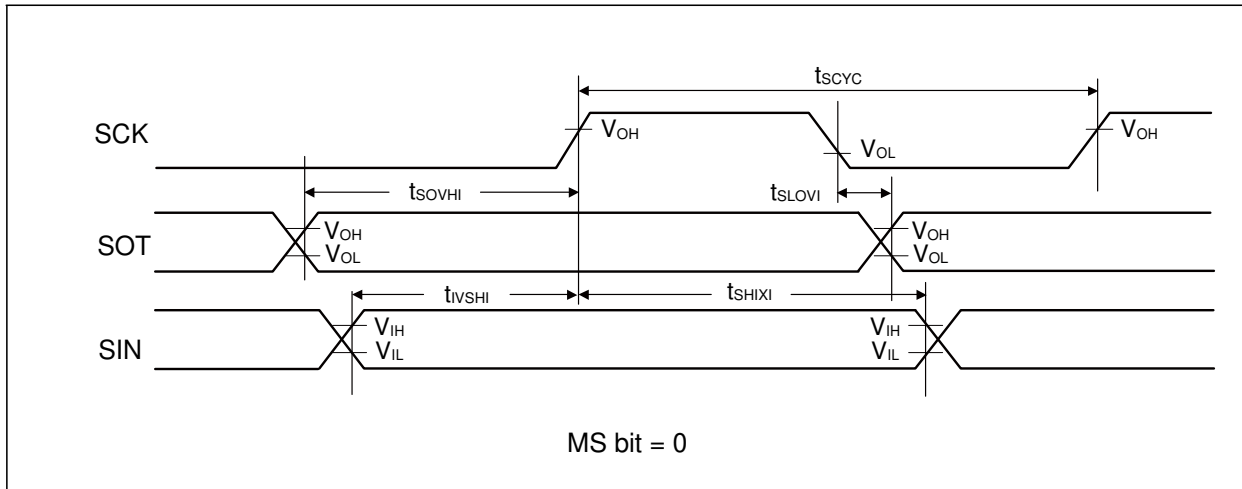

- External clock (EXT = 1) : asynchronous only

( $V_{CC} = 1.65V$  to  $3.6V$ ,  $V_{SS} = 0V$ ,  $T_a = -40^{\circ}C$  to  $+85^{\circ}C$ )

Parameter	Symbol	Conditions	Value		Unit	Remarks
			Min	Max		
Serial clock "L" pulse width	$t_{SLSH}$	$C_L = 30pF$	$t_{CYCP} + 10$	-	ns	
Serial clock "H" pulse width	$t_{SHSL}$		$t_{CYCP} + 10$	-	ns	
SCK falling time	$t_F$		-	5	ns	
SCK rising time	$t_R$		-	5	ns	

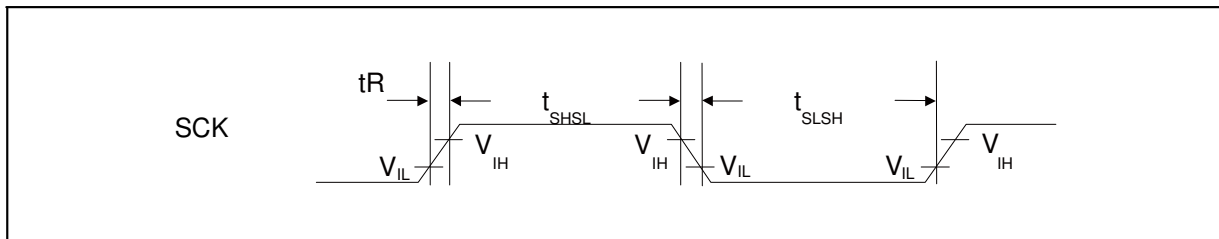

(10) External Input Timing

( $V_{CC} = 1.65V$  to  $3.6V$ ,  $V_{SS} = 0V$ ,  $T_a = -40^{\circ}C$  to  $+85^{\circ}C$ )

Parameter	Symbol	Pin name	Conditions	Value		Unit	Remarks
				Min	Max		
Input pulse width	$t_{INH}$ , $t_{INL}$	ADTG	-	$2t_{CYCP}^{*1}$	-	ns	A/D converter trigger input
		FRCKx					Free-run timer input clock
		ICxx					Input capture
		DTIxX	-	$2t_{CYCP} + 100^{*1}$	-	ns	External interrupt, NMI
		INT00 to INT15, NMIX					
		WKUPx	-	$600^{*3}$	-	ns	Deep standby wake up

\*1 :  $t_{CYCP}$  indicates the APB bus clock cycle time except stop when in STOP mode, in TIMER mode.

About the APB bus number which the Multi-function Timer is connected to, see "■BLOCK DIAGRAM" in this data sheet.

\*2 : When in STOP mode, in TIMER mode.

\*3 : When in Deep standby RTC mode, in Deep standby STOP mode.

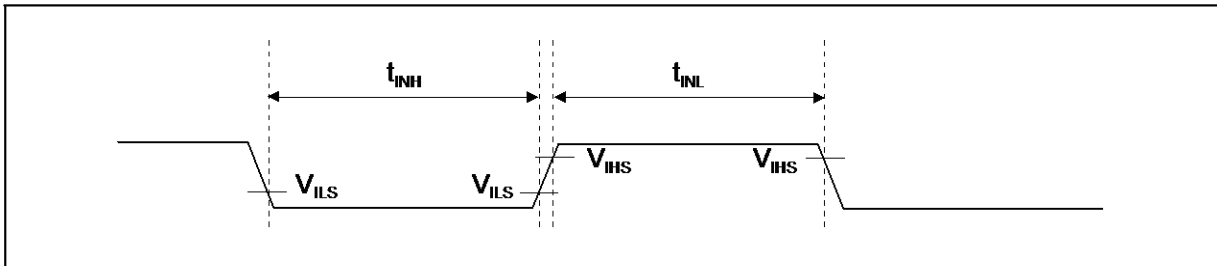



(11) Quadrature Position/Revolution Counter timing

( $V_{CC} = 1.65V$  to  $3.6V$ ,  $V_{SS} = 0V$ ,  $T_a = -40^{\circ}C$  to  $+85^{\circ}C$ )

Parameter	Symbol	Conditions	Value		Unit
			Min	Max	
AIN pin "H" width	$t_{AHL}$	-	$2t_{CYCP}^*$	-	ns
AIN pin "L" width	$t_{ALL}$	-			
BIN pin "H" width	$t_{BHL}$	-			
BIN pin "L" width	$t_{BLL}$	-			
BIN rising time from AIN pin "H" level	$t_{AUBU}$	PC_Mode2 or PC_Mode3			
AIN falling time from BIN pin "H" level	$t_{BUAD}$	PC_Mode2 or PC_Mode3			
BIN falling time from AIN pin "L" level	$t_{ADBD}$	PC_Mode2 or PC_Mode3			
AIN rising time from BIN pin "L" level	$t_{BDAU}$	PC_Mode2 or PC_Mode3			
AIN rising time from BIN pin "H" level	$t_{BUAU}$	PC_Mode2 or PC_Mode3			
BIN falling time from AIN pin "H" level	$t_{AUBD}$	PC_Mode2 or PC_Mode3			
AIN falling time from BIN pin "L" level	$t_{BDAD}$	PC_Mode2 or PC_Mode3			
BIN rising time from AIN pin "L" level	$t_{ADBU}$	PC_Mode2 or PC_Mode3			
ZIN pin "H" width	$t_{ZHL}$	QCR:CGSC="0"			
ZIN pin "L" width	$t_{ZLL}$	QCR:CGSC="0"			
AIN/BIN rising and falling time from determined ZIN level	$t_{ZABE}$	QCR:CGSC="1"			
Determined ZIN level from AIN/BIN rising and falling time	$t_{ABEZ}$	QCR:CGSC="1"			

\*:  $t_{CYCP}$  indicates the APB bus clock cycle time except stop when in STOP mode, in TIMER mode.  
 About the APB bus number which the Quadrature Position/Revolution Counter is connected to, see "■BLOCK DIAGRAM" in this data sheet.

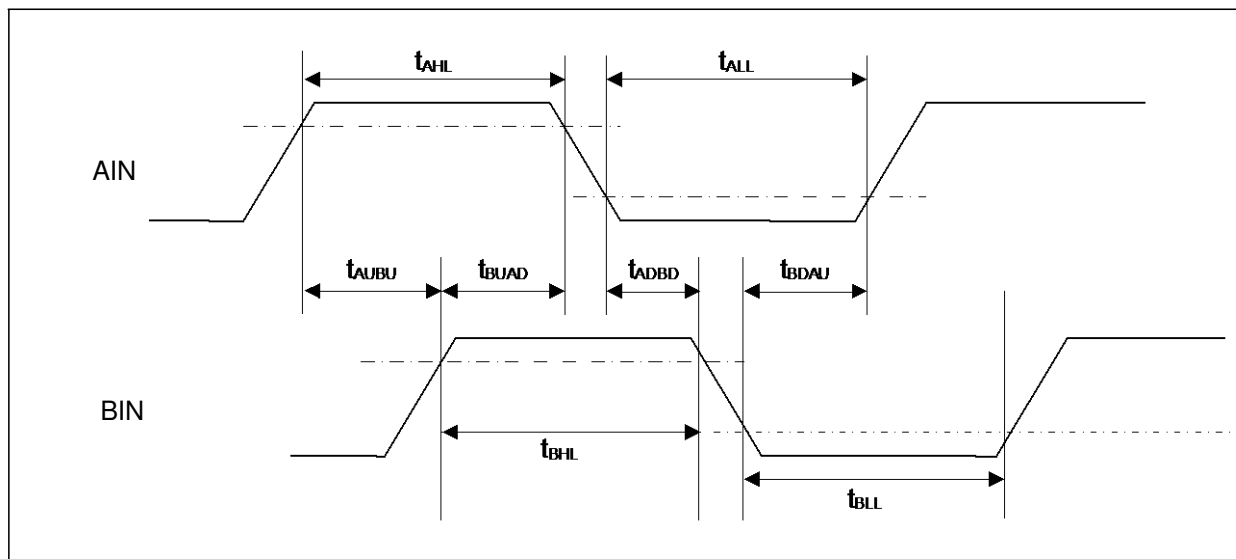

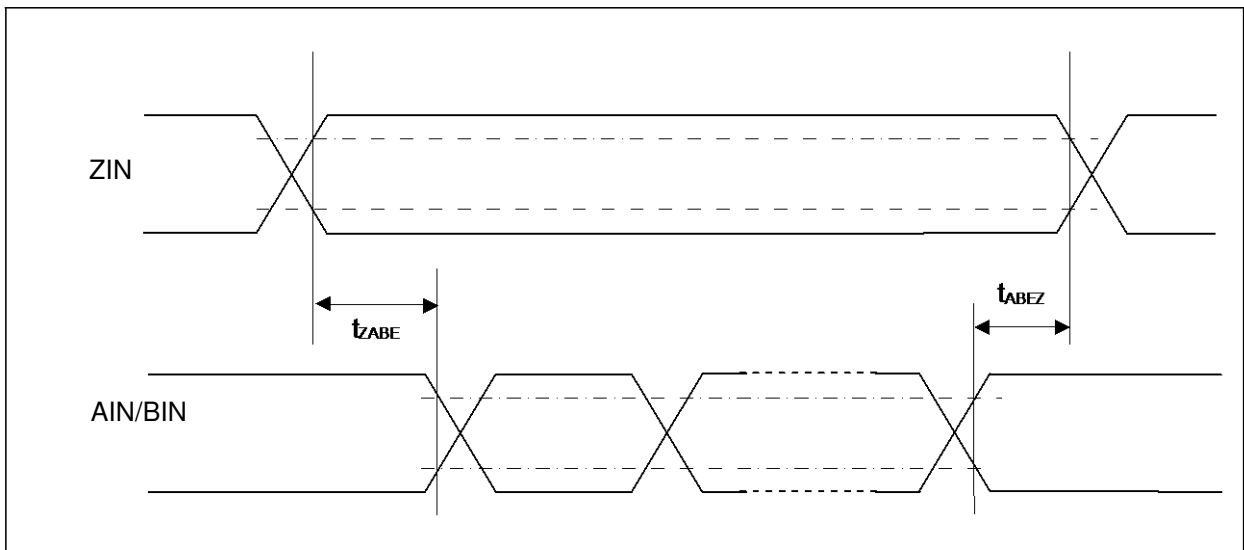
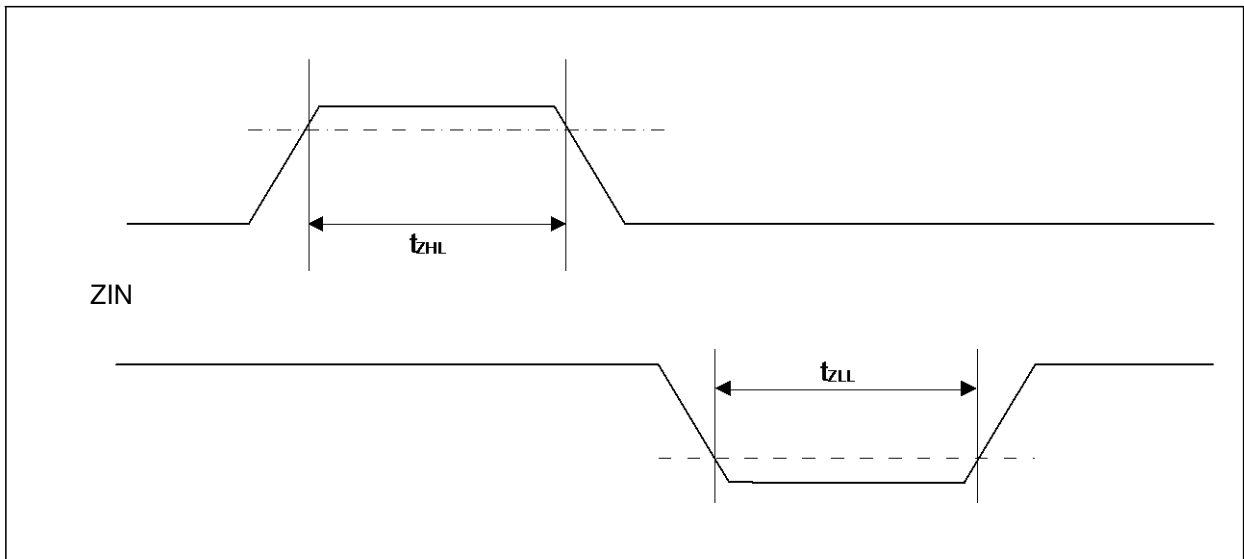
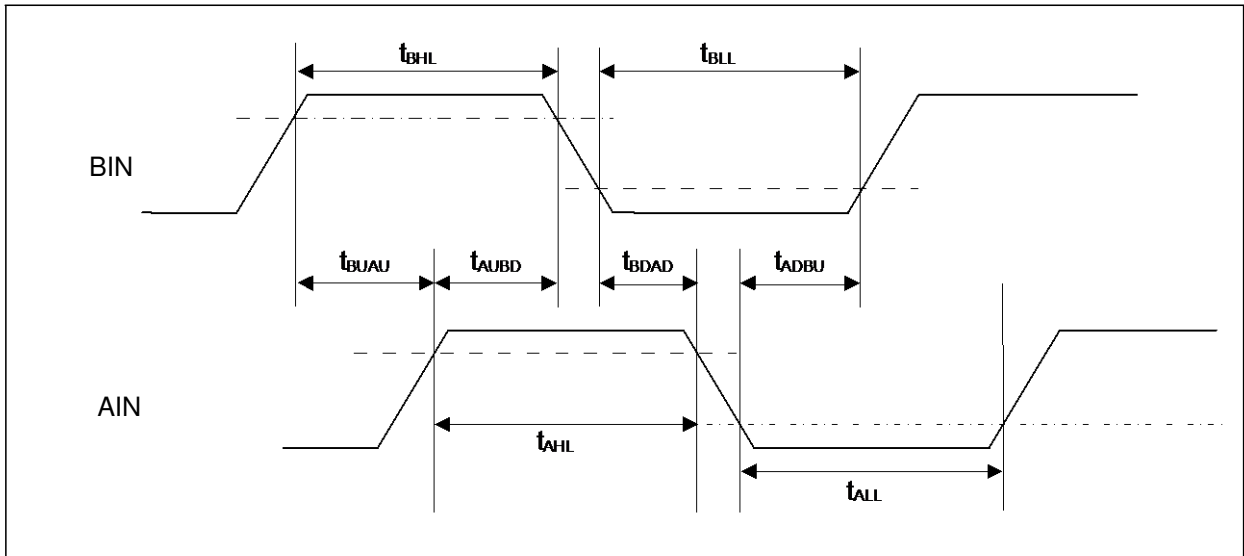

(12) I<sup>2</sup>C Timing

(V<sub>CC</sub> = 1.65V to 3.6V, V<sub>SS</sub> = 0V, T<sub>a</sub> = - 40°C to + 85°C)

Parameter	Symbol	Conditions	Standard-mode		Fast-mode		Unit	Remarks
			Min	Max	Min	Max		
SCL clock frequency	F <sub>SCL</sub>	C <sub>L</sub> = 30pF, R = (V <sub>p</sub> /I <sub>OL</sub> )* <sup>1</sup>	0	100	0	400	kHz	
(Repeated) START condition hold time SDA ↓ → SCL ↓	t <sub>HDSTA</sub>		4.0	-	0.6	-	μs	
SCL clock "L" width	t <sub>LOW</sub>		4.7	-	1.3	-	μs	
SCL clock "H" width	t <sub>HIGH</sub>		4.0	-	0.6	-	μs	
(Repeated) START condition setup time SCL ↑ → SDA ↓	t <sub>SUSTA</sub>		4.7	-	0.6	-	μs	
Data hold time SCL ↓ → SDA ↓ ↑	t <sub>HDDAT</sub>		0	3.45* <sup>2</sup>	0	0.9* <sup>3</sup>	μs	
Data setup time SDA ↓ ↑ → SCL ↑	t <sub>SUDAT</sub>		250	-	100	-	ns	
STOP condition setup time SCL ↑ → SDA ↑	t <sub>SUSTO</sub>		4.0	-	0.6	-	μs	
Bus free time between "STOP condition" and "START condition"	t <sub>BUF</sub>		4.7	-	1.3	-	μs	
Noise filter	t <sub>SP</sub>		-	2 t <sub>CYCP</sub> * <sup>4</sup>	-	2 t <sub>CYCP</sub> * <sup>4</sup>	-	ns

\*1: R and C<sub>L</sub> represent the pull-up resistor and load capacitance of the SCL and SDA lines, respectively.

V<sub>p</sub> indicates the power supply voltage of the pull-up resistor and I<sub>OL</sub> indicates V<sub>OL</sub> guaranteed current.

\*2: The maximum t<sub>HDDAT</sub> must satisfy that it does not extend at least "L" period (t<sub>LOW</sub>) of device's SCL signal.

\*3: A Fast-mode I<sup>2</sup>C bus device can be used on a Standard-mode I<sup>2</sup>C bus system as long as the device satisfies the requirement of "t<sub>SUDAT</sub> ≥ 250 ns".

\*4: t<sub>CYCP</sub> is the APB bus clock cycle time.

About the APB bus number that I<sup>2</sup>C is connected to, see "BLOCK DIAGRAM" in this data sheet.

To use Standard-mode, set the APB bus clock at 2 MHz or more.

To use Fast-mode, set the APB bus clock at 8 MHz or more.

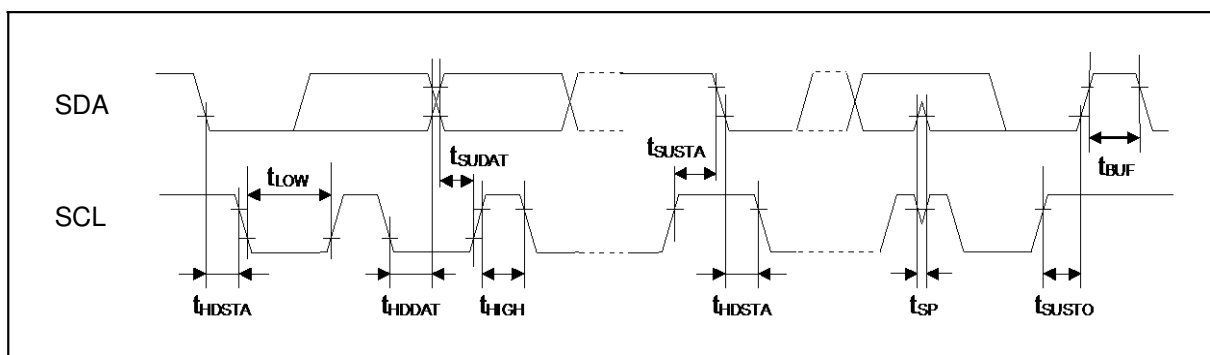

(13) ETM Timing

( $V_{CC} = 1.65V$  to  $3.6V$ ,  $V_{SS} = 0V$ ,  $T_a = -40^{\circ}C$  to  $+85^{\circ}C$ )

Parameter	Symbol	Pin name	Conditions	Value		Unit	Remarks
				Min	Max		
Data hold	$t_{ETMH}$	TRACECLK, TRACED[3:0]	$V_{CC} \geq 2.7V$	2	11	ns	
			$V_{CC} < 2.7V$	2	15		
TRACECLK frequency	$1/t_{TRACE}$	TRACECLK	$V_{CC} \geq 2.7V$	-	40	MHz	
			$V_{CC} < 2.7V$	-	20	MHz	
TRACECLK clock cycle	$t_{TRACE}$	TRACECLK	$V_{CC} \geq 2.7V$	25	-	ns	
			$V_{CC} < 2.7V$	50	-	ns	

Note: When the external load capacitance  $C_L = 30pF$ .

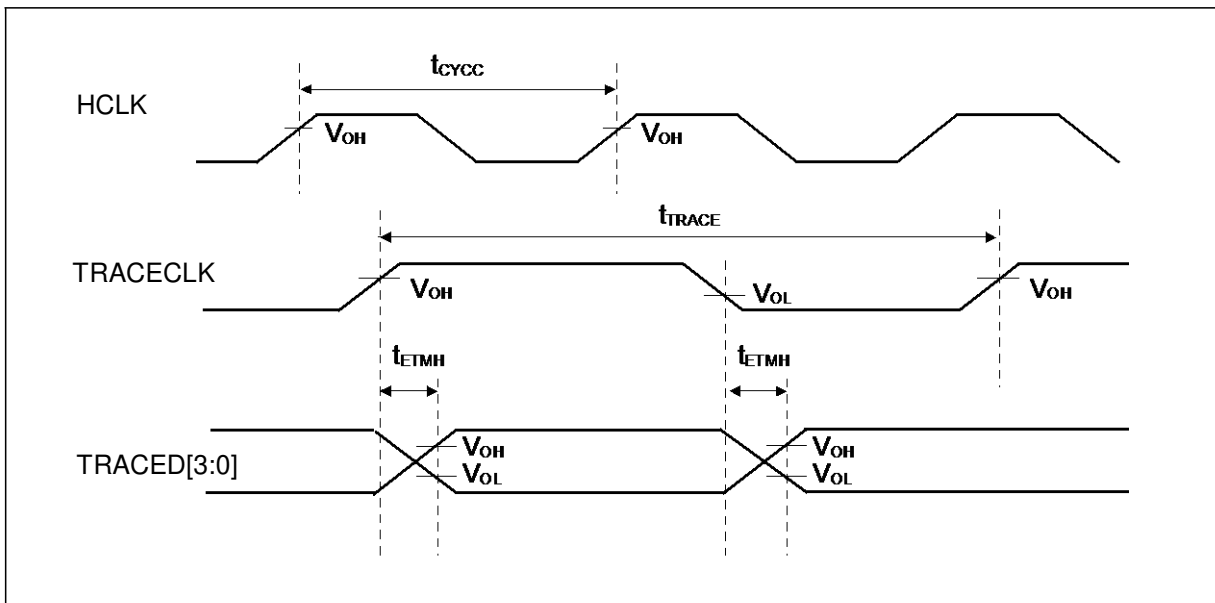

(14) JTAG Timing

( $V_{CC} = 1.65V$  to  $3.6V$ ,  $V_{SS} = 0V$ ,  $T_a = -40^{\circ}C$  to  $+85^{\circ}C$ )

Parameter	Symbol	Pin name	Conditions	Value		Unit	Remarks
				Min	Max		
TMS, TDI setup time	$t_{JTAGS}$	TCK, TMS, TDI	$V_{CC} \geq 2.7V$ $V_{CC} < 2.7V$	15	-	ns	
TMS, TDI hold time	$t_{JTAGH}$	TCK, TMS, TDI	$V_{CC} \geq 2.7V$ $V_{CC} < 2.7V$	15	-	ns	
TDO delay time	$t_{JTAGD}$	TCK, TDO	$V_{CC} \geq 2.7V$ $V_{CC} < 2.7V$	-	25 45	ns	

Note: When the external load capacitance  $C_L = 30pF$ .

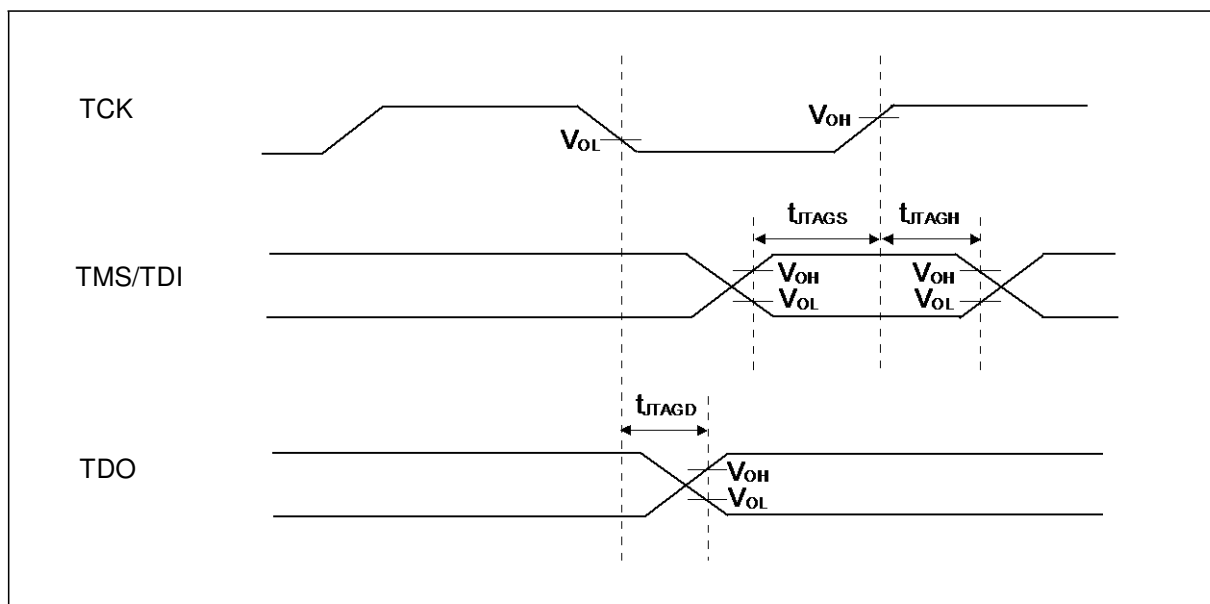

## 5. 12-bit A/D Converter

### • Electrical Characteristics for the A/D Converter

( $V_{CC} = AV_{CC} = 1.65V$  to  $3.6V$ ,  $V_{SS} = AV_{SS} = 0V$ ,  $T_a = -40^{\circ}C$  to  $+85^{\circ}C$ )

Parameter	Symbol	Pin name	Value			Unit	Remarks
			Min	Typ	Max		
Resolution	-	-	-	-	12	bit	
Integral Nonlinearity	-	-	- 4.5	-	+ 4.5	LSB	
Differential Nonlinearity	-	-	- 2.5	-	+ 2.5	LSB	
Zero transition voltage	$V_{ZT}$	ANxx	- 15	-	+ 15	mV	
Full-scale transition voltage	$V_{FST}$	ANxx	AVRH - 15	-	AVRH + 15	mV	
Conversion time	-	-	2.0* <sup>1</sup>	-	-	$\mu s$	$AV_{CC} \geq 2.7V$
Sampling time* <sup>2</sup>	$T_s$	-	0.6	-	10	$\mu s$	$AV_{CC} \geq 2.7V$
			1.2	-			$1.8V \leq AV_{CC} < 2.7V$
			3.0	-			$1.65V \leq AV_{CC} < 1.8V$
Compare clock cycle* <sup>3</sup>	Tcck	-	100	-	1000	ns	$AV_{CC} \geq 2.7V$
			200				$1.8V \leq AV_{CC} < 2.7V$
			500				$1.65V \leq AV_{CC} < 1.8V$
State transition time to operation permission	$T_{stt}$	-	-	-	1.0	$\mu s$	
Power supply current (analog + digital)	-	AVCC	-	0.27	0.42	mA	A/D 1unit operation
			-	0.03	10	$\mu A$	When A/D stop (All unit)
Reference power supply current (between AVRH to AVSS)	-	AVRH	-	0.72	1.29	mA	A/D 1unit operation AVRH=3.6V
			-	0.02	2.6	$\mu A$	When A/D stop (All unit)
Analog input capacity	$C_{AIN}$	-	-	-	9.4	pF	
Analog input resistor	$R_{AIN}$	-	-	-	2.2	$k\Omega$	$AV_{CC} \geq 2.7V$
					5.5		$1.8V \leq AV_{CC} < 2.7V$
					10.5		$1.65V \leq AV_{CC} < 1.8V$
Interchannel disparity	-	-	-	-	4	LSB	
Analog port input current	-	ANxx	-	-	5	$\mu A$	
Analog input voltage	-	ANxx	AVSS	-	AVRH	V	
Reference voltage	-	AVRH	2.7	-	AVCC	V	$AV_{CC} \geq 2.7V$
			AVCC				$AV_{CC} < 2.7V$

\*1: The conversion time is the value of sampling time ( $T_s$ ) + compare time ( $T_c$ ).

The condition of the minimum conversion time is when the value of sampling time: 600ns, the value of compare time: 1400ns ( $AV_{CC} \geq 2.7V$ ).

Ensure that it satisfies the value of the sampling time ( $T_s$ ) and compare clock cycle ( $T_{cck}$ ).

For setting of the sampling time and compare clock cycle, see "Chapter: A/D Converter" in "FM3 Family PERIPHERAL MANUAL Analog Macro Part".

The A/D Converter register are reflected in the operation according to the APB bus clock timing.

The sampling clock and compare clock is generated from the Base clock (HCLK).

About the APB bus number which the A/D Converter is connected to, see "■BLOCK DIAGRAM" in this data sheet.

\*2: A necessary sampling time changes by external impedance.

Ensure that it sets the sampling time to satisfy (Equation 1).

\*3: The compare time ( $T_c$ ) is the value of (Equation 2).

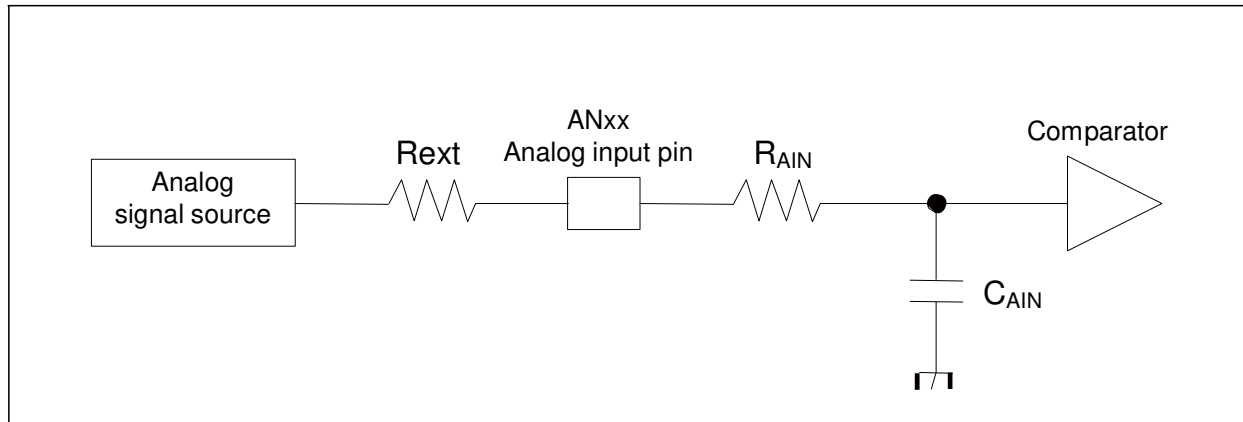

$$\text{(Equation 1) } T_s \geq (R_{AIN} + R_{ext}) \times C_{AIN} \times 9$$

$T_s$  : Sampling time[ns]

$R_{AIN}$  : input resistor of A/D[k $\Omega$ ] = 2.2k $\Omega$  at 2.7V  $\leq$  AVCC  $\leq$  3.6V

input resistor of A/D[k $\Omega$ ] = 5.5k $\Omega$  at 1.8V  $\leq$  AVCC  $\leq$  2.7V

input resistor of A/D[k $\Omega$ ] = 10.5k $\Omega$  at 1.65V  $\leq$  AVCC  $\leq$  1.8V

$C_{AIN}$  : input capacity of A/D[pF] = 9.4pF at 1.65V  $\leq$  AVCC  $\leq$  3.6V

$R_{ext}$  : Output impedance of external circuit[k $\Omega$ ]

$$\text{(Equation 2) } T_c = T_{cck} \times 14$$

$T_c$  : Compare time

$T_{cck}$  : Compare clock cycle

• Definition of 12-bit A/D Converter Terms

- Resolution : Analog variation that is recognized by an A/D converter.
- Integral Nonlinearity : Deviation of the line between the zero-transition point (0b000000000000 ↔ 0b000000000001) and the full-scale transition point (0b111111111110 ↔ 0b111111111111) from the actual conversion characteristics.
- Differential Nonlinearity : Deviation from the ideal value of the input voltage that is required to change the output code by 1 LSB.

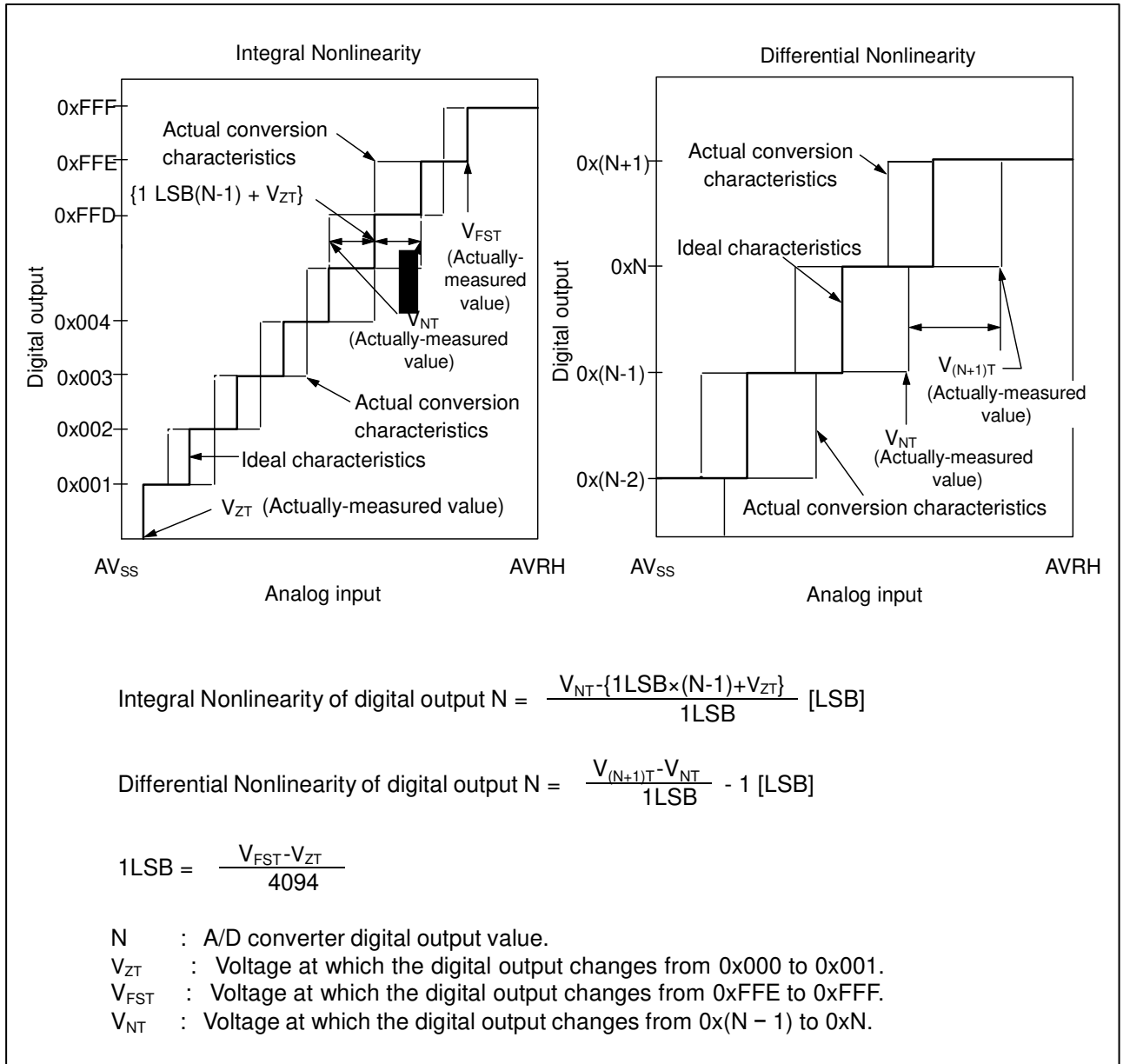



## 6. Low-Voltage Detection Characteristics

## (1) Low-Voltage Detection Reset

(Ta = - 40°C to + 85°C)

Parameter	Symbol	Conditions	Value			Unit	Remarks
			Min	Typ	Max		
Detected voltage	VDL	SVHR* <sup>1</sup> = 00000	1.38	1.50	1.60	V	When voltage drops
Released voltage	VDH		1.43	1.55	1.65	V	When voltage rises
Detected voltage	VDL	SVHR* <sup>1</sup> = 00001	1.43	1.55	1.65	V	When voltage drops
Released voltage	VDH		Same as SVHR = 00000 value			V	When voltage rises
Detected voltage	VDL	SVHR* <sup>1</sup> = 00010	1.47	1.60	1.73	V	When voltage drops
Released voltage	VDH		Same as SVHR = 00000 value			V	When voltage rises
Detected voltage	VDL	SVHR* <sup>1</sup> = 00011	1.52	1.65	1.78	V	When voltage drops
Released voltage	VDH		Same as SVHR = 00000 value			V	When voltage rises
Detected voltage	VDL	SVHR* <sup>1</sup> = 00100	1.56	1.70	1.84	V	When voltage drops
Released voltage	VDH		Same as SVHR = 00000 value			V	When voltage rises
Detected voltage	VDL	SVHR* <sup>1</sup> = 00101	1.61	1.75	1.89	V	When voltage drops
Released voltage	VDH		Same as SVHR = 00000 value			V	When voltage rises
Detected voltage	VDL	SVHR* <sup>1</sup> = 00110	1.66	1.80	1.94	V	When voltage drops
Released voltage	VDH		Same as SVHR = 00000 value			V	When voltage rises
Detected voltage	VDL	SVHR* <sup>1</sup> = 00111	1.70	1.85	2.00	V	When voltage drops
Released voltage	VDH		Same as SVHR = 00000 value			V	When voltage rises
Detected voltage	VDL	SVHR* <sup>1</sup> = 01000	1.75	1.90	2.05	V	When voltage drops
Released voltage	VDH		Same as SVHR = 00000 value			V	When voltage rises
Detected voltage	VDL	SVHR* <sup>1</sup> = 01001	1.79	1.95	2.11	V	When voltage drops
Released voltage	VDH		Same as SVHR = 00000 value			V	When voltage rises
Detected voltage	VDL	SVHR* <sup>1</sup> = 01010	1.84	2.00	2.16	V	When voltage drops
Released voltage	VDH		Same as SVHR = 00000 value			V	When voltage rises
Detected voltage	VDL	SVHR* <sup>1</sup> = 01011	1.89	2.05	2.21	V	When voltage drops
Released voltage	VDH		Same as SVHR = 00000 value			V	When voltage rises
Detected voltage	VDL	SVHR* <sup>1</sup> = 01100	2.30	2.50	2.70	V	When voltage drops
Released voltage	VDH		Same as SVHR = 00000 value			V	When voltage rises
Detected voltage	VDL	SVHR* <sup>1</sup> = 01101	2.39	2.60	2.81	V	When voltage drops
Released voltage	VDH		Same as SVHR = 00000 value			V	When voltage rises
Detected voltage	VDL	SVHR* <sup>1</sup> = 01110	2.48	2.70	2.92	V	When voltage drops
Released voltage	VDH		Same as SVHR = 00000 value			V	When voltage rises
Detected voltage	VDL	SVHR* <sup>1</sup> = 01111	2.58	2.80	3.02	V	When voltage drops
Released voltage	VDH		Same as SVHR = 00000 value			V	When voltage rises
Detected voltage	VDL	SVHR* <sup>1</sup> = 10000	2.67	2.90	3.13	V	When voltage drops
Released voltage	VDH		Same as SVHR = 00000 value			V	When voltage rises
Detected voltage	VDL	SVHR* <sup>1</sup> = 10001	2.76	3.00	3.24	V	When voltage drops
Released voltage	VDH		Same as SVHR = 00000 value			V	When voltage rises
Detected voltage	VDL	SVHR* <sup>1</sup> = 10010	2.85	3.10	3.35	V	When voltage drops
Released voltage	VDH		Same as SVHR = 00000 value			V	When voltage rises
Detected voltage	VDL	SVHR* <sup>1</sup> = 10011	2.94	3.20	3.46	V	When voltage drops
Released voltage	VDH		Same as SVHR = 00000 value			V	When voltage rises
LVD stabilization wait time	T <sub>LVDW</sub>	-	-	-	5200 × t <sub>CYCP</sub> * <sup>2</sup>	μs	
LVD detection delay time	T <sub>LVDL</sub>	-	-	-	200	μs	

\*1: The SVHR bit of Low-Voltage Detection Voltage Control Register (LVD\_CTL) is initialized to "00000" by Low-Voltage Detection Reset.

\*2: t<sub>CYCP</sub> indicates the APB2 bus clock cycle time.

(2) Interrupt of Low-Voltage Detection

(Ta = - 40°C to + 85°C)

Parameter	Symbol	Conditions	Value			Unit	Remarks
			Min	Typ	Max		
Detected voltage	VDL	SVHI = 00100	1.56	1.70	1.84	V	When voltage drops
Released voltage	VDH		1.61	1.75	1.89	V	When voltage rises
Detected voltage	VDL	SVHI = 00101	1.61	1.75	1.89	V	When voltage drops
Released voltage	VDH		1.66	1.80	1.94	V	When voltage rises
Detected voltage	VDL	SVHI = 00110	1.66	1.80	1.94	V	When voltage drops
Released voltage	VDH		1.70	1.85	2.00	V	When voltage rises
Detected voltage	VDL	SVHI = 00111	1.70	1.85	2.00	V	When voltage drops
Released voltage	VDH		1.75	1.90	2.05	V	When voltage rises
Detected voltage	VDL	SVHI = 01000	1.75	1.90	2.05	V	When voltage drops
Released voltage	VDH		1.79	1.95	2.11	V	When voltage rises
Detected voltage	VDL	SVHI = 01001	1.79	1.95	2.11	V	When voltage drops
Released voltage	VDH		1.84	2.00	2.16	V	When voltage rises
Detected voltage	VDL	SVHI = 01010	1.84	2.00	2.16	V	When voltage drops
Released voltage	VDH		1.89	2.05	2.21	V	When voltage rises
Detected voltage	VDL	SVHI = 01011	1.89	2.05	2.21	V	When voltage drops
Released voltage	VDH		1.93	2.10	2.27	V	When voltage rises
Detected voltage	VDL	SVHI = 01100	2.30	2.50	2.70	V	When voltage drops
Released voltage	VDH		2.39	2.60	2.81	V	When voltage rises
Detected voltage	VDL	SVHI = 01101	2.39	2.60	2.81	V	When voltage drops
Released voltage	VDH		2.48	2.70	2.92	V	When voltage rises
Detected voltage	VDL	SVHI = 01110	2.48	2.70	2.92	V	When voltage drops
Released voltage	VDH		2.58	2.80	3.02	V	When voltage rises
Detected voltage	VDL	SVHI = 01111	2.58	2.80	3.02	V	When voltage drops
Released voltage	VDH		2.67	2.90	3.13	V	When voltage rises
Detected voltage	VDL	SVHI = 10000	2.67	2.90	3.13	V	When voltage drops
Released voltage	VDH		2.76	3.00	3.24	V	When voltage rises
Detected voltage	VDL	SVHI = 10001	2.76	3.00	3.24	V	When voltage drops
Released voltage	VDH		2.85	3.10	3.35	V	When voltage rises
Detected voltage	VDL	SVHI = 10010	2.85	3.10	3.35	V	When voltage drops
Released voltage	VDH		2.94	3.20	3.46	V	When voltage rises
Detected voltage	VDL	SVHI = 10011	2.94	3.20	3.46	V	When voltage drops
Released voltage	VDH		3.04	3.30	3.56	V	When voltage rises
LVD stabilization wait time	T <sub>LVDW</sub>	-	-	-	5200 × t <sub>CYCP</sub> *	μs	
LVD detection delay time	T <sub>LVDL</sub>	-	-	-	200	μs	

\*: t<sub>CYCP</sub> indicates the APB2 bus clock cycle time.

## 7. Flash Memory Write/Erase Characteristics

### (1) Write / Erase time

( $V_{CC} = 1.65V$  to  $3.6V$ ,  $T_a = -40^{\circ}C$  to  $+85^{\circ}C$ )

Parameter		Value			Unit	Remarks
		Min	Typ	Max		
Sector erase time	Large Sector	-	1.1	2.7	s	Includes write time prior to internal erase
	Small Sector		0.3	0.9		
Half word (16-bit) write time		-	30	528	$\mu s$	Not including system-level overhead time
Chip erase time		-	11.2	30.5	s	Includes write time prior to internal erase

### (2) Write cycles and data hold time

Erase/write cycles (cycle)	Data hold time (year)	Remarks
1,000	20*	
10,000	10*	

\*: This value comes from the technology qualification (using Arrhenius equation to translate high temperature acceleration test result into average temperature value at  $+85^{\circ}C$ ).

■ ORDERING INFORMATION

Part number	Package
MB9AF154MAPMC	Plastic • LQFP 80-pin (0.5mm pitch), (FPT-80P-M37)
MB9AF155MAPMC	
MB9AF156MAPMC	
MB9AF154MAPMC1	Plastic • LQFP 80-pin (0.65mm pitch), (FPT-80P-M40)
MB9AF155MAPMC1	
MB9AF156MAPMC1	
MB9AF154MABGL	Plastic • PFBGA 96-pin (0.5mm pitch), (BGA-96P-M07)
MB9AF155MABGL	
MB9AF156MABGL	
MB9AF154NAPMC	Plastic • LQFP 100-pin (0.5mm pitch), (FPT-100P-M23)
MB9AF155NAPMC	
MB9AF156NAPMC	
MB9AF154NAPQC	Plastic • QFP 100-pin (0.65mm pitch), (FPT-100P-M36)
MB9AF155NAPQC	
MB9AF156NAPQC	
MB9AF154NABGL	Plastic • PFBGA 112-pin (0.8mm pitch), (BGA-112P-M04)
MB9AF155NABGL	
MB9AF156NABGL	
MB9AF154RAPMC	Plastic • LQFP 120-pin (0.5mm pitch), (FPT-120P-M37)
MB9AF155RAPMC	
MB9AF156RAPMC	

■ PACKAGE DIMENSIONS

<p>120-pin plastic LQFP</p> <p>(FPT-120P-M37)</p>	Lead pitch	0.50 mm
	Package width × package length	16.0 mm × 16.0 mm
	Lead shape	Gullwing
	Sealing method	Plastic mold
	Mounting height	1.70 mm Max
	Weight	0.88 g
	Code (Reference)	P-LFQFP120-16 × 16-0.50

120-pin plastic LQFP (FPT-120P-M37)

Note 1) \* : These dimensions do not include resin protrusion.  
 Note 2) Pins width and pins thickness include plating thickness.  
 Note 3) Pins width do not include tie bar cutting remainder.

Dimensions in mm (inches).  
 Note: The values in parentheses are reference values

© 2010 FUJITSU SEMICONDUCTOR LIMITED F120037Sc(1)-1-1

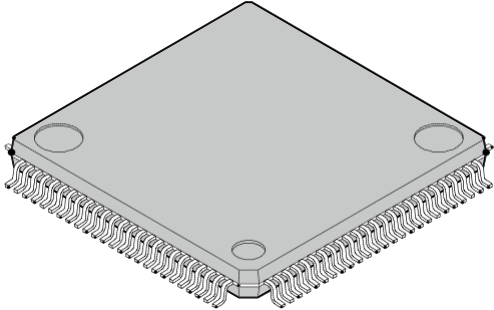
<p>100-pin plastic LQFP</p>  <p>(FPT-100P-M23)</p>	Lead pitch	0.50 mm
	Package width × package length	14.00 mm × 14.00 mm
	Lead shape	Gullwing
	Lead bend direction	Normal bend
	Sealing method	Plastic mold
	Mounting height	1.70 mm MAX
	Weight	0.65 g

100-pin plastic LQFP (FPT-100P-M23)

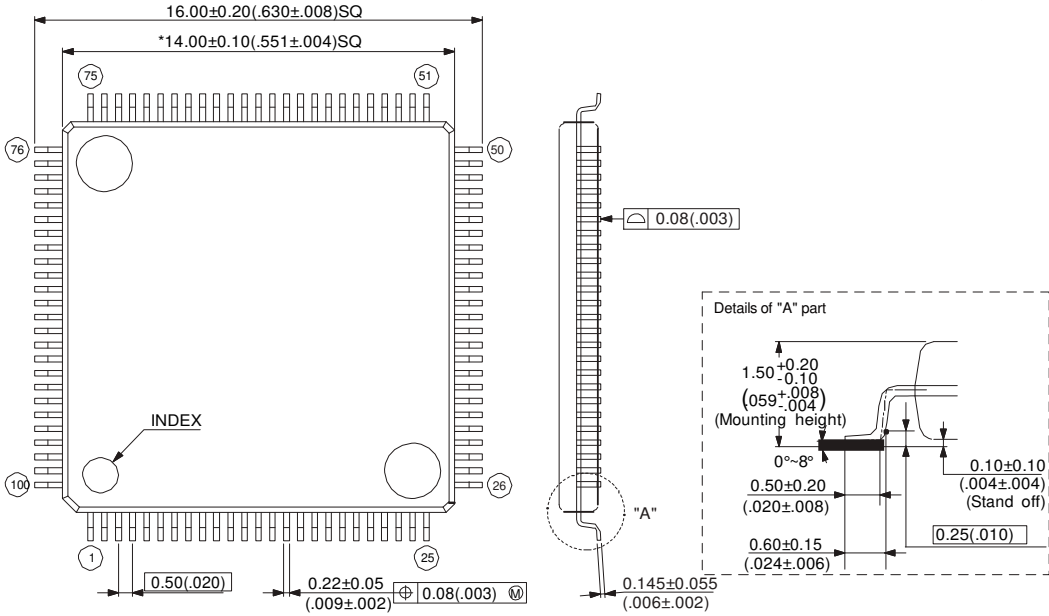

Note 1) \* : These dimensions do not include resin protrusion.  
 Note 2) Pins width and pins thickness include plating thickness.  
 Note 3) Pins width do not include tie bar cutting remainder.

© 2009-2010 FUJITSU SEMICONDUCTOR LIMITED F100034S-c-3-4

Dimensions in mm (inches).  
 Note: The values in parentheses are reference values.

Please check the latest package dimension at the following URL.  
<http://edevic.fujitsu.com/package/en-search/>

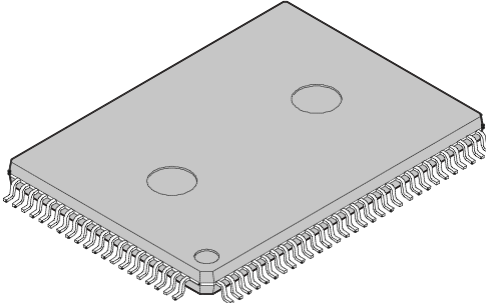
<p style="text-align: center;">100-pin plastic QFP</p>  <p style="text-align: center;">(FPT-100P-M36)</p>	Lead pitch	0.65 mm
	Package width × package length	14.00 mm × 20.00 mm
	Lead shape	Gullwing
	Sealing method	Plastic mold
	Mounting height	3.35 mm MAX
	Code (Reference)	P-QFP100-14 × 20-0.65

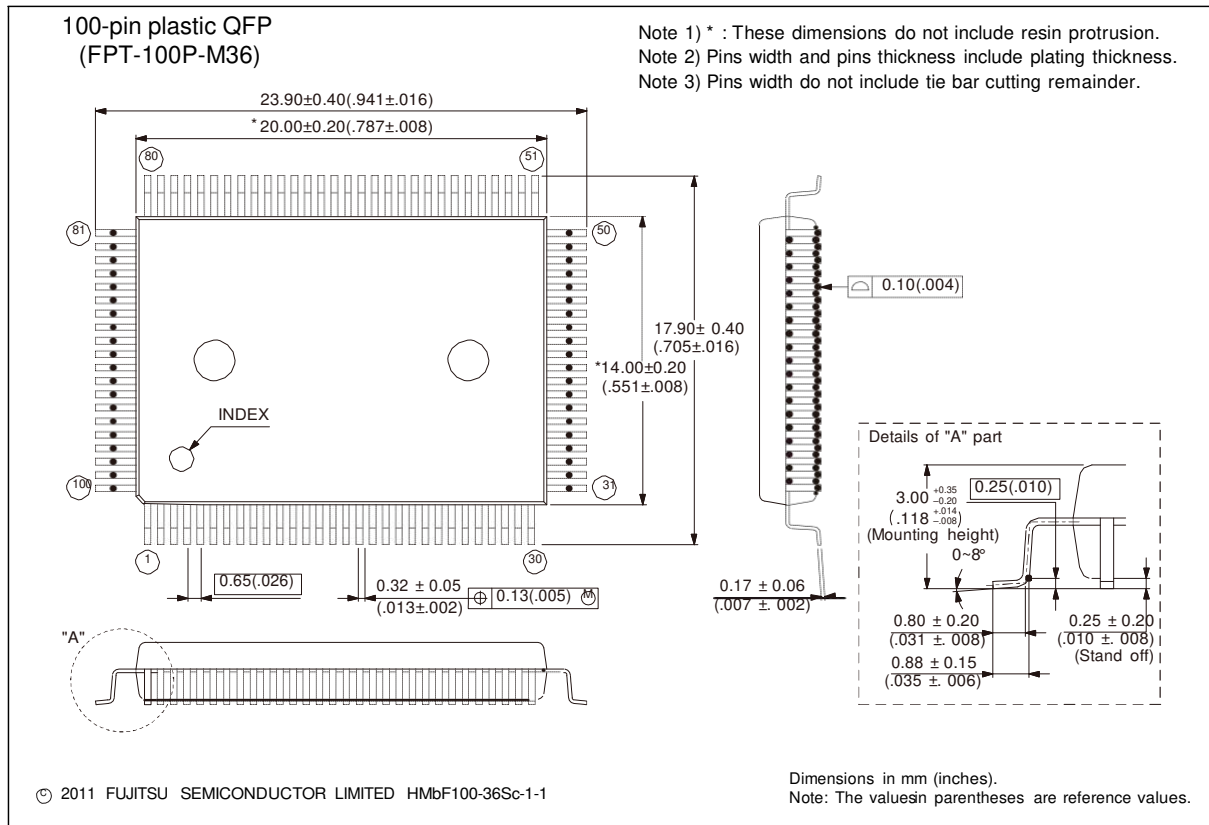

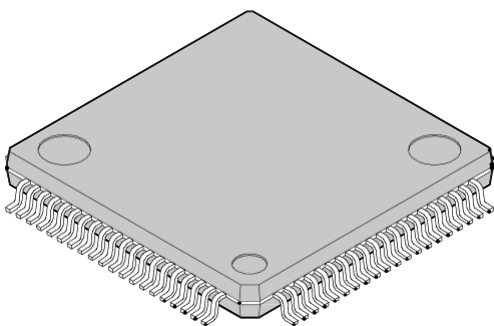
<p style="text-align: center;">80-pin plastic LQFP</p>  <p style="text-align: center;">(FPT-80P-M37)</p>	Lead pitch	0.50 mm
	Package width × package length	12.00 mm × 12.00 mm
	Lead shape	Gullwing
	Lead bend direction	Normal bend
	Sealing method	Plastic mold
	Mounting height	1.70 mm MAX
	Weight	0.47 g

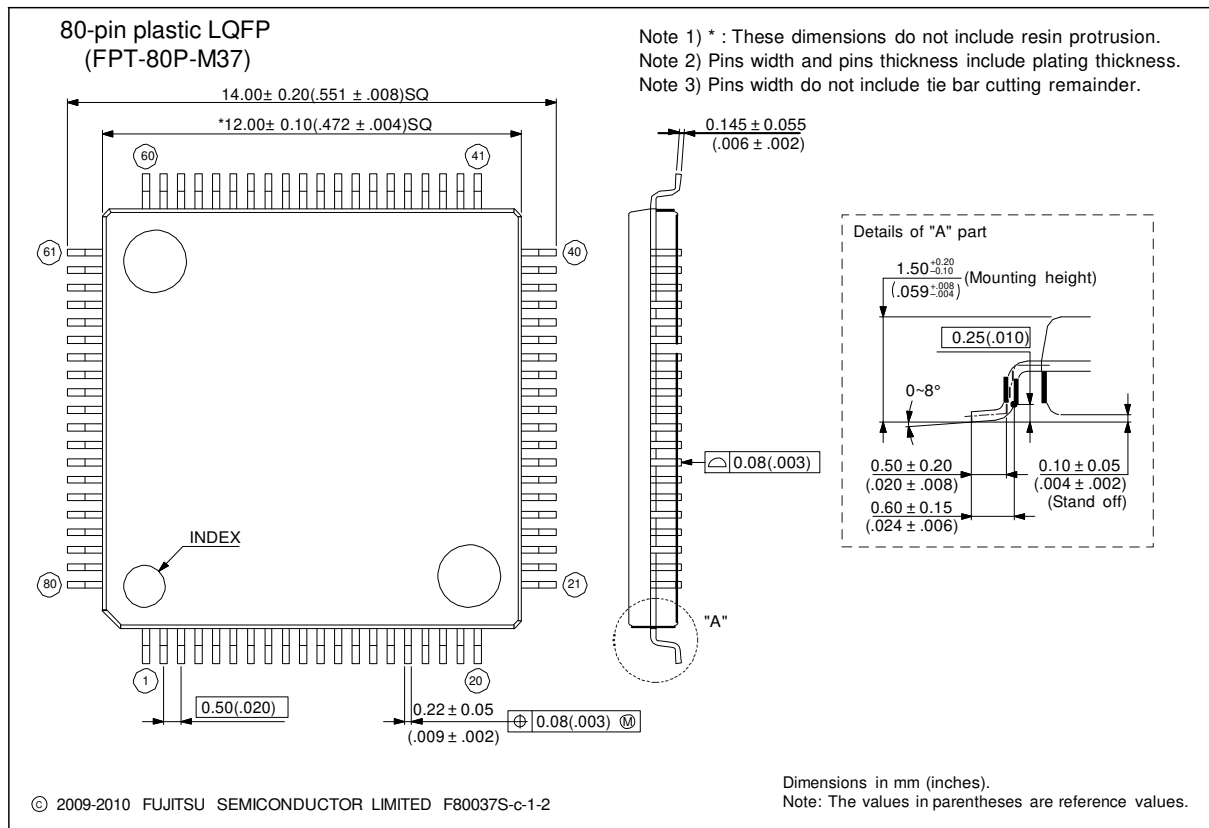

Please check the latest package dimension at the following URL.  
<http://edevic.fujitsu.com/package/en-search/>

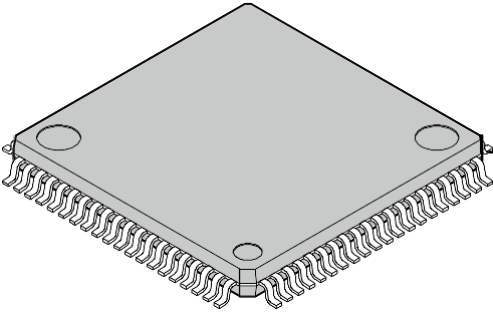

<p style="text-align: center;">80-pin plastic LQFP</p>  <p style="text-align: center;">(FPT-80P-M40)</p>	Lead pitch	0.65 mm
	Package width × package length	14.00 mm × 14.00 mm
	Lead shape	Gullwing
	Sealing method	Plastic mold
	Mounting height	1.60 mm Max.
	Code (Reference)	P-LQFP80-14 × 14-0.65

80-pin plastic LQFP  
(FPT-80P-M40)

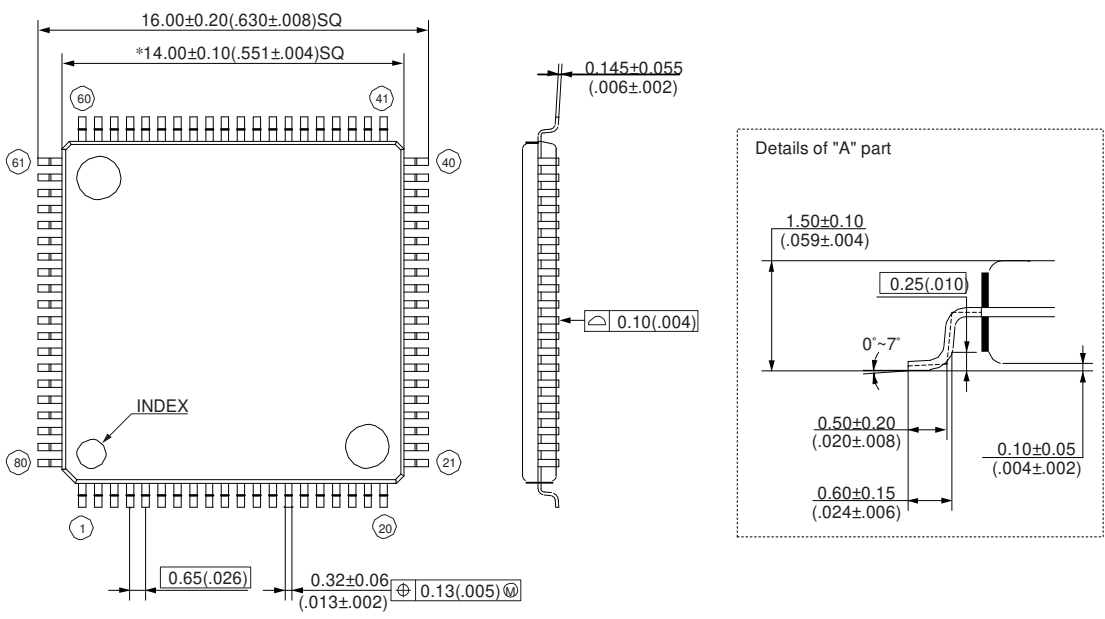

Note 1) \* : These dimensions do not include resin protrusion.  
 Note 2) Pins width and pins thickness include plating thickness.  
 Note 3) Pins width do not include tie bar cutting remainder.

© 2012 FUJITSU SEMICONDUCTOR LIMITED HMBF80-40Sc-1-1

Dimensions in mm (inches).  
Note: The values in parentheses are reference values.

Please check the latest package dimension at the following URL.  
<http://edevice.fujitsu.com/package/en-search/>

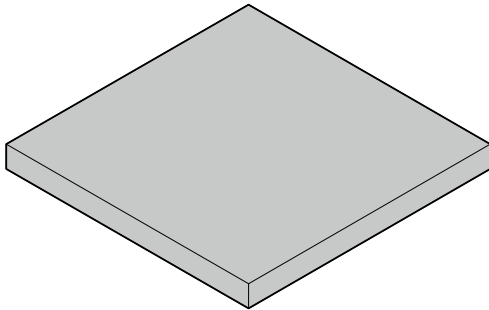
<p>112-ball plastic PFBGA</p>  <p>(BGA-112P-M04)</p>	Ball pitch	0.80 mm
	Package width × package length	10.00 × 10.00 mm
	Lead shape	Soldering ball
	Sealing method	Plastic mold
	Ball size	Φ 0.45 mm
	Mounting height	1.45 mm Max.
	Weight	0.22 g

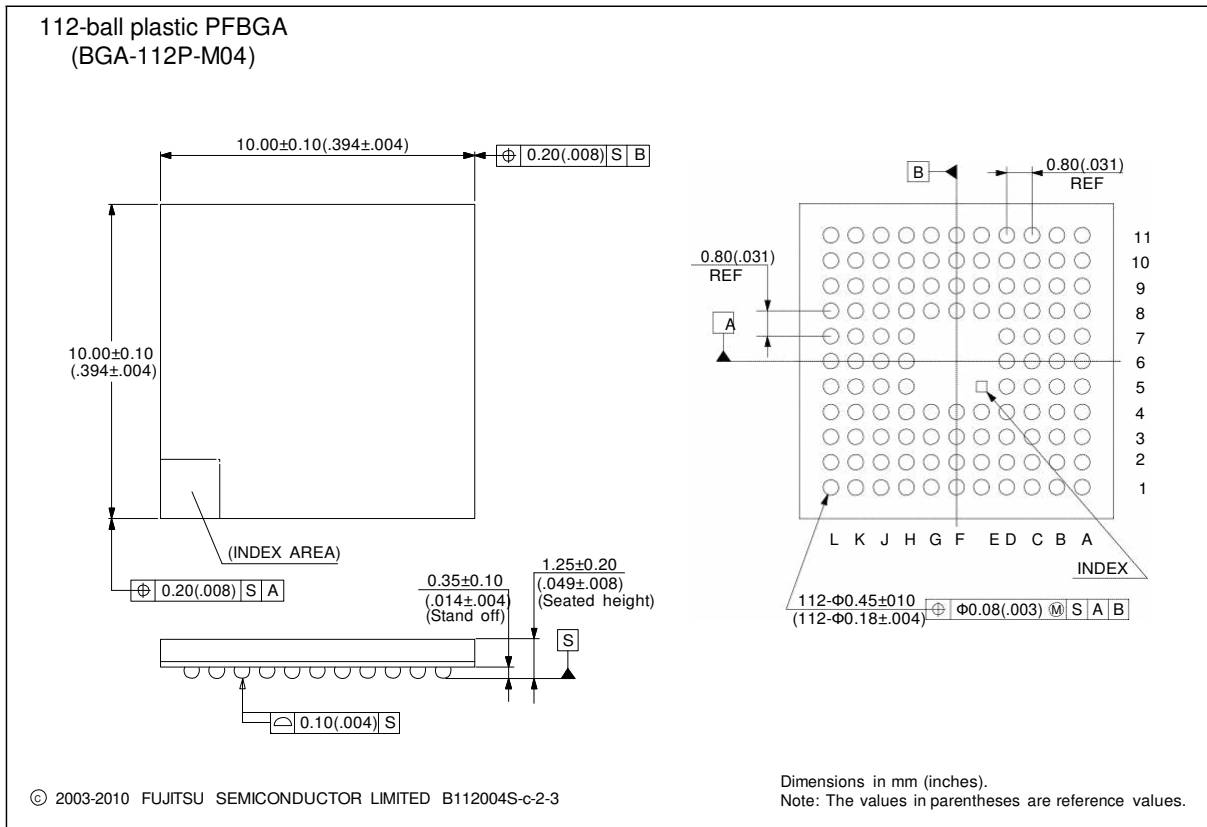

Please check the latest package dimension at the following URL.  
<http://edevic.fujitsu.com/package/en-search/>

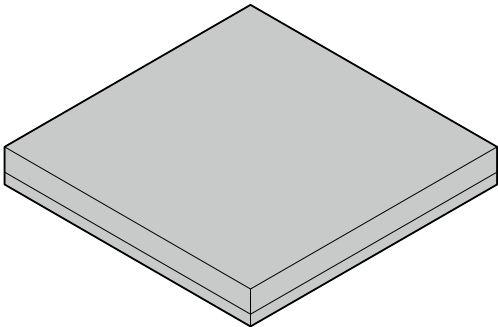
<p>96-pin plastic FBGA</p>  <p>(BGA-96P-M07)</p>	Lead pitch	0.5 mm
	Package width × package length	6.00 mm × 6.00 mm
	Lead shape	Ball
	Sealing method	Plastic mold
	Mounting height	1.30 mm MAX
	Weight	0.08 g

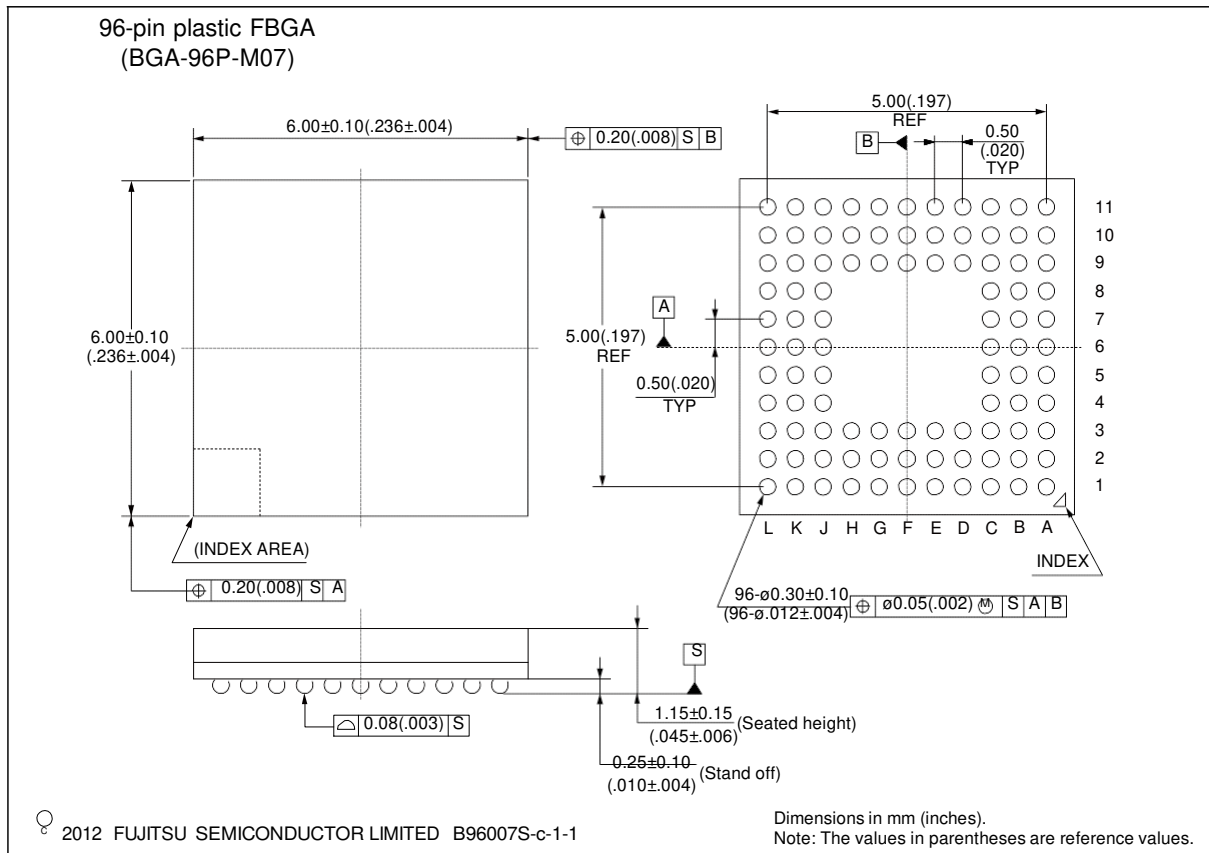

■ MAJOR CHANGES

Page	Section	Change Results
Revision 0.1		
-	-	Initial release
Revision 1.0		
-	-	Preliminary → Data Sheet
2	■ FEATURES ● On-chip Memories	Corrected the description of "Flash memory".
8	■ PRODUCT LINEUP ● Function	Corrected the value of channel number of the "Base Timer".
62	■ HANDLING DEVICES	<ul style="list-style-type: none"> <li>Added the description of "Crystal oscillator circuit".</li> <li>Added the description of "Sub crystal oscillator".</li> </ul>
65	■ BLOCK DIAGRAM	Corrected the figure. <ul style="list-style-type: none"> <li>TIOA: input → input/output</li> <li>TIOB: output → input</li> </ul>
66	■ MEMORY MAP ● Memory Map (1)	Corrected the value of address of "SRAM0".
67	● Memory Map (2)	Added the footnote.
71, 72	■ PIN STATUS IN EACH CPU STATE ● List of Pin Status	<ul style="list-style-type: none"> <li>Corrected the Return from Deep standby mode state of "Pin status type H".</li> <li>Corrected the function group of "Pin status type I".</li> </ul>
77, 78	■ ELECTRICAL CHARACTERISTICS 3. DC Characteristics (1) Current Rating	<ul style="list-style-type: none"> <li>Revised the value of "TBD".</li> <li>Revised the typical value of "Power supply voltage (<math>I_{CCH}</math>, <math>I_{CCT}</math>, <math>I_{CCR}</math>)".</li> <li>Added the "Flash Memory Write/Erase current (<math>I_{CCFLASH}</math>)".</li> <li>Added the footnote.</li> </ul>
81	4. AC Characteristics (2) Sub Clock Input Characteristics	<ul style="list-style-type: none"> <li>Added the description of Note of "Input frequency (<math>F_{CL}</math>)".</li> <li>Added the footnote.</li> </ul>
	(3) Built-in CR Oscillation Characteristics ● Built-in high-speed CR	<ul style="list-style-type: none"> <li>Revised the condition.</li> <li>Corrected the value.</li> <li>Added the item of "Frequency stabilization time".</li> <li>Added the footnote.</li> </ul>
85, 86	(7) External Bus Timing ● Separate Bus Access Asynchronous SRAM Mode	<ul style="list-style-type: none"> <li>Corrected the value.</li> <li>Deleted the "MWEX ↓ → Data output time".</li> <li>Added the "MCSX ↓ → Data output time".</li> <li>Corrected the figure.</li> </ul>
87	● Separate Bus Access Synchronous SRAM Mode	<ul style="list-style-type: none"> <li>Corrected the "MCLK↑ → Data output time".</li> <li>Added the "MCLK↑ → Data hold time".</li> <li>Corrected the figure.</li> </ul>
95, 97, 99, 101	(9) CSIO Timing	Corrected the description of section title. UART Timing → CSIO Timing
		Corrected the description of "Note". UART is connected → Multi-function Serial is connected
106	(12) I <sup>2</sup> C Timing	Added the footnote.
109	5. 12-bit A/D Converter	<ul style="list-style-type: none"> <li>Revised the parameter.</li> <li>Revised the symbol.</li> <li>Corrected the value.</li> </ul>
111	Definition of 12-bit A/D Converter Terms	<ul style="list-style-type: none"> <li>Revised the parameter.</li> <li>Revised the symbol.</li> </ul>
112	6. Low-Voltage Detection Characteristics (1) Low-Voltage Detection Reset	<ul style="list-style-type: none"> <li>Corrected "Conditions" and "Value" in the table.</li> <li>Added the Item.</li> <li>Added the footnote.</li> </ul>
113	(2) Interrupt of Low-Voltage Detection	Added the Item.
Revision 1.1		
-	-	Company name and layout design change
Revision 2.0		
-	-	Corrected the Series name. MB9A150R Series → MB9A150RA Series
-	-	Corrected the Product name as follows. MB9AF156MA, MB9AF155MA, MB9AF154MA MB9AF156NA, MB9AF155NA, MB9AF154NA MB9AF156RA, MB9AF155RA, MB9AF154RA
2	■ FEATURES ● External Bus Interface	Added the Item. ● Maximum area size : Up to 256 Mbytes
2	● Multi-function Serial Interface	Corrected the description of "I <sup>2</sup> C"
4	● Multi-function Timer	Corrected the channel count of "A/D activation compare"
8	■ PRODUCT LINEUP ● Function	Added the footnote

Page	Section	Change Results
9	■ PACKAGES	Delete the following packages. •FPT-100P-M36 •FPT-80P-M40
-	■ PIN ASSIGNMENT ● FPT-100P-M36	Delete the Item
12	● FPT-80P-M37	Corrected the description of section title. ● FPT-80P-M37/M40 → ● FPT-80P-M37
15 - 30	■ LIST OF PIN FUNCTION • List of numbers	Delete column of terminal number "QFP-100"
31 - 52	• List of pin functions	Delete column of terminal number "QFP-100"
65	■ MEMORY MAP • Memory Map (1)	Corrected the address "External Device Area"
75	■ ELECTRICAL CHARACTERISTICS 2.Recommended Operating Conditions	Add the footnote
76, 77	3.DC Characteristics (1)Current rating	•Corrected the Condition •Delete the minmun value •Corrected the remarks •Add the footnote
101	(9)CSIO Timing •Synchronous serial (SPI=1, SCINV=1)	Corrected the figure of "MS bit=1"
101	(9) CSIO Timing • External clock(EXT=1):asyntironous only	Corrected the figure
102	(10)External Input Timing	Add the terminal as follows •FRCKx •ICxx •DTTlxX
105	(12)I <sup>2</sup> C Timing	Corrected the description as follows. •Typical mode → Standard-mode •High-speed mode → Fast-mode
108	5.12-bit A/D Converter •Electrical Characteristics for the A/D Converter	•Corrected the terminal name AN00 to AN23 → ANxx •Corrected the minmun value of "Sampling time" •Corrected the max and min value of "State transition time to operationpermission" •Corrected the footnote
114	■ ORDERING INFORMATON	Corrected the "Part number"





**Colophon**

The products described in this document are designed, developed and manufactured as contemplated for general use, including without limitation, ordinary industrial use, general office use, personal use, and household use, but are not designed, developed and manufactured as contemplated (1) for any use that includes fatal risks or dangers that, unless extremely high safety is secured, could have a serious effect to the public, and could lead directly to death, personal injury, severe physical damage or other loss (i.e., nuclear reaction control in nuclear facility, aircraft flight control, air traffic control, mass transport control, medical life support system, missile launch control in weapon system), or (2) for any use where chance of failure is intolerable (i.e., submersible repeater and artificial satellite). Please note that Spansion will not be liable to you and/or any third party for any claims or damages arising in connection with above-mentioned uses of the products. Any semiconductor devices have an inherent chance of failure. You must protect against injury, damage or loss from such failures by incorporating safety design measures into your facility and equipment such as redundancy, fire protection, and prevention of over-current levels and other abnormal operating conditions. If any products described in this document represent goods or technologies subject to certain restrictions on export under the Foreign Exchange and Foreign Trade Law of Japan, the US Export Administration Regulations or the applicable laws of any other country, the prior authorization by the respective government entity will be required for export of those products.

**Trademarks and Notice**

The contents of this document are subject to change without notice. This document may contain information on a Spansion product under development by Spansion. Spansion reserves the right to change or discontinue work on any product without notice. The information in this document is provided as is without warranty or guarantee of any kind as to its accuracy, completeness, operability, fitness for particular purpose, merchantability, non-infringement of third-party rights, or any other warranty, express, implied, or statutory. Spansion assumes no liability for any damages of any kind arising out of the use of the information in this document.

Copyright © 2012-2014 Spansion Inc. All rights reserved. Spansion®, the Spansion logo, MirrorBit®, MirrorBit® Eclipse™, ORNAND™ and combinations thereof, are trademarks and registered trademarks of Spansion LLC in the United States and other countries. Other names used are for informational purposes only and may be trademarks of their respective owners.