

© - TE Connectivity. All Rights Reserved.

REVISIONS				
P	LTR	DESCRIPTION	DATE	APVD
	R6	REVISED PER ECN-22-156403	03JUN2022	RK CSD

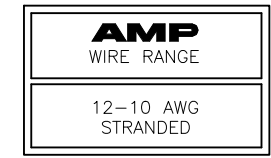
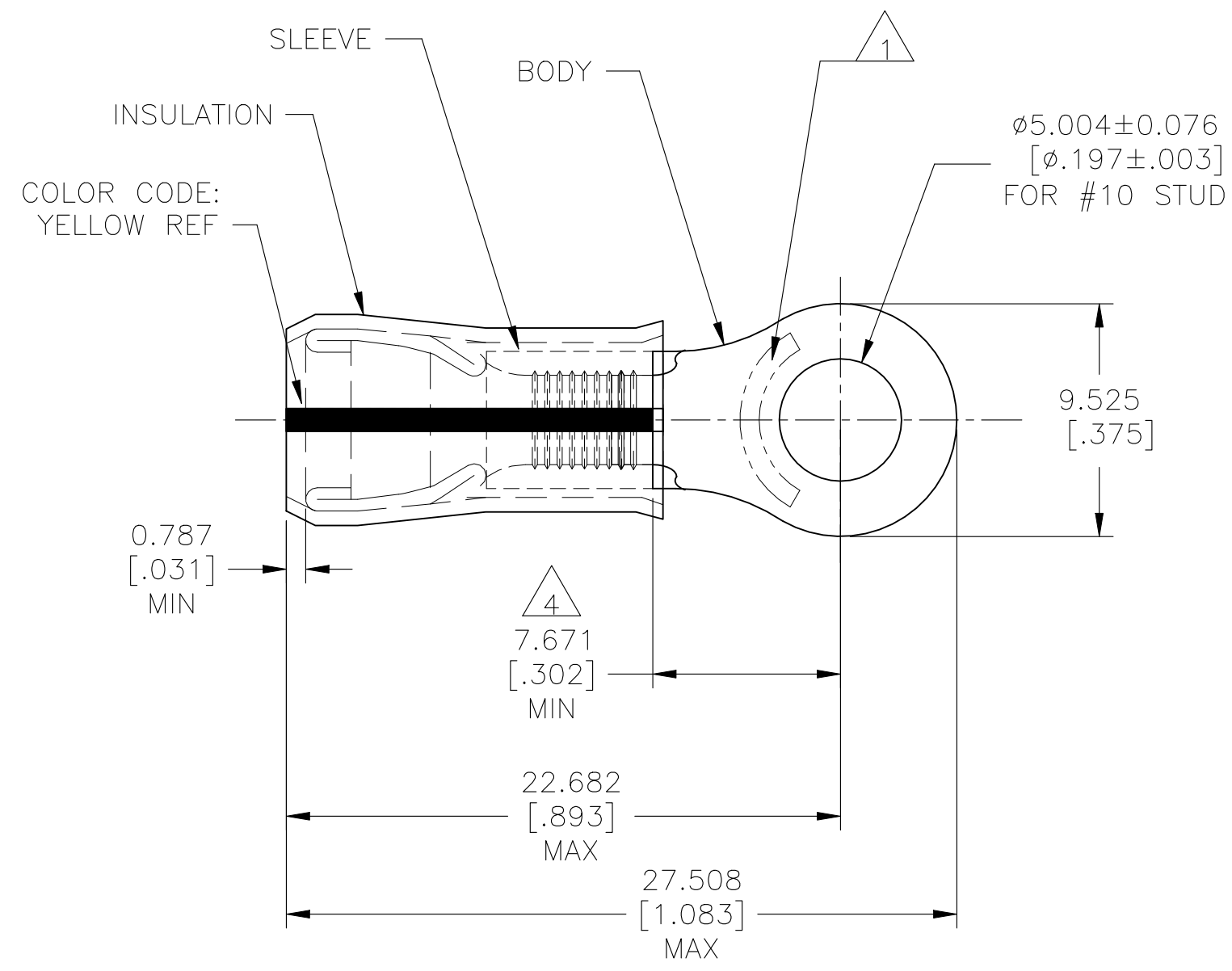

- 1 STAMP AMP 12-10* APPROX AS SHOWN.
- 2 WIRE INSULATION : $\phi 3.810-5.842$ [$\phi 0.150-.230$]
- 3 BODY MATERIAL THK: 0.991 ± 0.051 [0.039 ± 0.002]
- 4 APPLIES FROM EDGE OF METAL WIRE BARREL TO CENTER OF STUD HOLE.
- 5 MEETS M7928/4-112, CLASS 1
MEETS M7928/13-112, CLASS 1
- 6 NOTE DELETED.
- 7 MATERIAL:
BODY & SLEEVE: COPPER PER ASTM B152
INSULATION: PVF²
- 8 FINISH:
BODY & SLEEVE: TIN-LEAD (93-7) PLATE PER
ASTM B545 (3% MIN LEAD CONTENT)
INSULATION: COLOR-NATURAL

500	LOOSE PIECE	53425-1
QTY	PACKAGE TYPE	PART NO

AMP INCORPORATED CUSTOMER SERVICE SYSTEMS		MAX RECOMMENDED OPERATING TEMPERATURE: 150°C [302°F] MAX	THIS DRAWING IS A CONTROLLED DOCUMENT.		DWN JR RUTH 160CT07	TE Connectivity					
FOR ADDITIONAL PRODUCT INFORMATION OR COPIES OF DRAWINGS AND TECHNICAL DOCUMENTS	PRODUCT INFORMATION CENTER 1-800-522-6752	VOLTAGE RATING: -	DIMENSIONS: mm [INCHES]	TOLERANCES UNLESS OTHERWISE SPECIFIED:	CHK T MICHELUTTI 160CT07				NAME TERMINAL, RING TONGUE, PVF2 , P.I.D.G. WIRE SIZE: 12-10 AWG		
FOR APPLICATION TOOLING INFORMATION	TOOLING ASSISTANCE CENTER 1-800-722-1111	CIRCULAR MIL AREA: 2.62-6.64mm ² [5,180-13,100] STRANDED		0 PLC ± - 1 PLC ± - 2 PLC ± - 3 PLC ± 0.127[.005] 4 PLC ± - ± - ANGLES	APVD T MICHELUTTI 160CT07	APPLICATION SPEC 114-2157	SIZE A3	CAGE CODE 00779	DRAWING NO C-53425	RESTRICTED TO -	
FOR ORDER ENTRY	1-800-526-5142	THIS DRAWING IS A CONTROLLED DOCUMENT FOR AMP INCORPORATED. IT IS SUBJECT TO CHANGE AND THE CONTROLLING ENGINEERING ORGANIZATION SHOULD BE CONTACTED FOR THE LATEST REVISION.	MATERIAL 	FINISH 	PRODUCT SPEC -	WEIGHT -	CUSTOMER DRAWING		SCALE 4:1	SHEET 1 OF 1	REV R6