

Detector Power Management System with Horn Driver and CO Op Amp

Features

- Low Quiescent Current
- Operation from 2V or 12V
- 9.8V Boost Regulator
- Horn Driver
- LED Driver
- 3.3V Regulated Voltage for Microcontroller Operation
- Internal Operational Amplifiers:
 - ± 1 mV Input Offset Voltage
 - Rail-to-Rail Input and Output
 - 10 kHz Gain Bandwidth Product
 - Unity Gain Stable
- Bidirectional Alarm Interconnect

Applications

- CO Detector
- Toxic Gas Detector
- Heat Detector

Description

The RE46C800 provides all of the analog, interface, and power management functions for a microcontroller based CO or toxic gas detector. The RE46C800 can also be used in any smoke detector application requiring the power management, horn driver and interconnect functions provided by this CMOS ASIC. It is intended for use in both 3V and 9V battery or battery-backed applications. It features a boost regulator and horn driver circuit suitable for driving a piezoelectric horn, a 3.3V regulator for microcontroller voltage regulation, an LED driver, an operational amplifier and an IO for communication with interconnected units.

Package Types

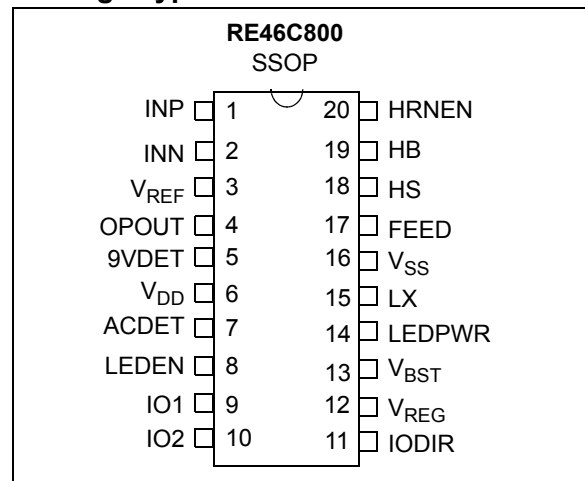

RE46C800

Functional Block Diagram

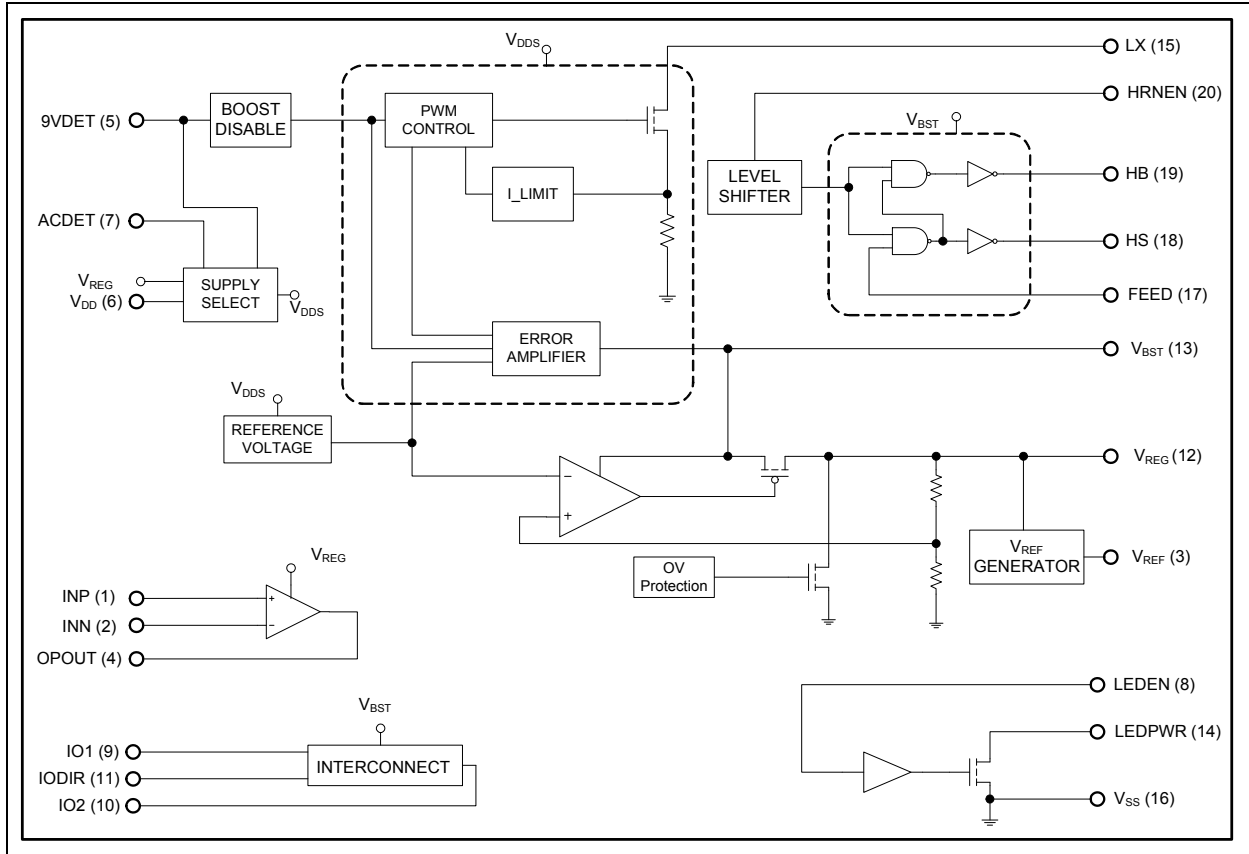

1.0 ELECTRICAL CHARACTERISTICS

1.1 Absolute Maximum Ratings†

V _{DD}	-0.3V to 5.5V
ESD HBM.....	1500V
ESD MM.....	150V
V _{BST} , LX	-0.3V to 13V
Input Voltage Range Except ACDET, 9VDET, FEED, IO1	V _{IN1} = - .3V to V _{REG} + .3V
ACDET, 9VDET Input Voltage Range	V _{IN2} = - .3V to V _{BST} + .3V
FEED Input Voltage Range	V _{INFD} = -10V to + 22V
IO1 Input Voltage Range.....	V _{INIO1} = - .3 to +15V
Input Current except FEED.....	I _{IN} = 10 mA
Operating Temperature	T _A = -10°C to +60°C
Storage Temperature	T _{STG} = -55°C to +125°C
Maximum Junction Temperature.....	T _J = +150°C

† **Notice:** Stresses above those listed under “Maximum Ratings” may cause permanent damage to the device. This is a stress rating only and functional operation of the device at these or any other conditions above those indicated in the operation listings of this specification is not implied. Exposure to maximum rating conditions for extended periods may affect device reliability.

DC ELECTRICAL CHARACTERISTICS – RE46C800

Unless otherwise indicated, all parameters apply at T_A = -10°C to +60°C, V_{DD} = 3V, V_{SS} = 0V, C_{REG} = 10 μF, C_{BST} = 10 μF, 9VDET low, ACDET low. (Note 1) (Note 2) (Note 3)

Parameter	Symbol	Test Pin	Min.	Typ.	Max.	Units	Conditions
Supply Voltage	V _{DD}	6	2	—	5	V	Operating
	V _{BST}	13	6	—	12	V	Operating, 9V operation, 9VDET or ACDET high
Standby Supply Current	I _{DDSTBY1}		—	13.6	—	μA	Inputs low; No loads, boost regulator running (Note 4)
	I _{DDSTBY2}		—	5.8	9.3	μA	Inputs low; No loads, boost regulator disabled, 9V operation, V _{BST} = 9V, 9VDET high
Quiescent Supply Current	I _{DDQ}	6	—	6.8	10.3	μA	Inputs low; No loads; V _{BST} = 5V; V _{LX} = 0.5V
Quiescent I _{VO}	I _{VOQ}	13	—	3.6	5.2	μA	Inputs low; No loads; V _{BST} = 5V; V _{LX} = 0.5V

- Note** 1: Wherever a specific V_{BST} value is listed under test conditions, the V_{BST} is forced externally with the inductor disconnected and the boost regulator is NOT running.
- 2: Typical values are for design information only.
- 3: The limits shown are 100% tested at 25°C only. Test limits are guard-banded based on temperature characterization to warrant compliance at temperature extremes.
- 4: The Standby Supply Current I_{DDSTBY1} specified above can be approximated as follows:
- $$I_{DDSTBY1} = I_{DDQ} + I_{IND}$$
- Where I_{DDQ} = average current into V_{DD} supply
- $$I_{IND} = \text{average inductor current} = V_{BST} * I_{VOQ} / (V_{IN} * \text{Efficiency})$$
- $$V_{IN} = V_{DD} = 3V$$

RE46C800

DC ELECTRICAL CHARACTERISTICS – RE46C800 (CONTINUED)

Unless otherwise indicated, all parameters apply at $T_A = -10^\circ\text{C}$ to $+60^\circ\text{C}$, $V_{DD} = 3\text{V}$, $V_{SS} = 0\text{V}$, $C_{REG} = 10\ \mu\text{F}$, $C_{BST} = 10\ \mu\text{F}$, 9VDET low, ACDET low. (Note 1) (Note 2) (Note 3)

Parameter	Symbol	Test Pin	Min.	Typ.	Max.	Units	Conditions
Input Leakage Low	I_{IL}	1, 5, 7, 8, 10, 11, 20	—	—	-100	nA	INP, 9VDET, ACDET, LEDEN, IO2, IODIR, HRNEN Inputs $V_{IN} = V_{SS}$
	I_{ILOP}	2	—	—	-200	pA	INN input, $V_{IN} = V_{SS}$
	I_{ILF}	17	—	-15	-50	μA	FEED = -10V, $V_{BST} = 10\text{V}$
Input Leakage High	I_{IH1}	1, 8, 10, 11, 20	—	—	100	nA	INP, LEDEN, IO2, IODIR, HRNEN Inputs $V_{IN} = V_{REG}$
	I_{IH2}	5, 7	—	—	100	nA	9VDET, ACDET Inputs, $V_{IN} = V_{BST}$, $V_{BST} = 10\text{V}$.
	I_{IHOP}	2	—	—	200	pA	INN input, $V_{IN} = V_{REG}$
	I_{IHF}	17	—	20	50	μA	FEED = +22V; $V_{BST} = 10\text{V}$
Output Off Leakage High	I_{IHOZ}	14, 15	—	—	1	μA	LEDEN = V_{SS} , LEDPWR, LX = $V_{BST} = 10\text{V}$
Input Voltage Low	V_{IL1}	8, 10, 11, 20	—	—	1	V	LEDEN, IO2, IODIR, HRNEN Inputs
	V_{IL2}	7	—	—	7	V	ACDET Input, $V_{BST} = 10\text{V}$
	V_{IL3}	5	—	—	4	V	9VDET Input, $V_{BST} = 10\text{V}$
	V_{ILF}	17	—	—	3	V	FEED Input; $V_{BST} = 10\text{V}$
	V_{ILIO1}	9	—	—	0.8	V	Falling edge of IO1 input, IODIR = V_{SS}
Input Voltage High	V_{IH1}	8, 10, 11, 20	$V_{REG} - 0.7$	—	—	V	LEDEN, IO2, IODIR, HRNEN Inputs
	V_{IH2}	7	8.2	—	—	V	ACDET Input, $V_{BST} = 10\text{V}$
	V_{IH3}	5	6	—	—	V	9VDET Input, $V_{BST} = 10\text{V}$
	V_{IHF}	17	7	—	—	V	FEED Input; $V_{BST} = 10\text{V}$
	V_{IHIO1}	9	2	—	—	V	Rising edge of IO1 input, IODIR = V_{SS}
Output Voltage Low	V_{OL1}	18, 19	—	—	0.5	V	HS or HB; $I_{OUT} = 16\ \text{mA}$; $V_{DD} = 3\text{V}$; $V_{BST} = 10\text{V}$, HRNEN = V_{SS}
	V_{OL2}	14	—	—	0.5	V	LEDPWR; $I_{OUT} = 10\ \text{mA}$; $V_{BST} = 10\text{V}$
	V_{OLIO2}	10	—	—	0.5	V	IO2 output, $I_{OUT} = 100\ \mu\text{A}$, IODIR = V_{SS}

- Note 1:** Wherever a specific V_{BST} value is listed under test conditions, the V_{BST} is forced externally with the inductor disconnected and the boost regulator is NOT running.
- Note 2:** Typical values are for design information only.
- Note 3:** The limits shown are 100% tested at 25°C only. Test limits are guard-banded based on temperature characterization to warrant compliance at temperature extremes.
- Note 4:** The Standby Supply Current $I_{DDSTBY1}$ specified above can be approximated as follows:

$$I_{DDSTBY1} = I_{DDQ} + I_{IND}$$

Where I_{DDQ} = average current into V_{DD} supply

$$I_{IND} = \text{average inductor current} = V_{BST} * IVOQ / (V_{IN} * \text{Efficiency})$$

$$V_{IN} = V_{DD} = 3\text{V}$$

DC ELECTRICAL CHARACTERISTICS – RE46C800 (CONTINUED)

Unless otherwise indicated, all parameters apply at $T_A = -10^\circ\text{C}$ to $+60^\circ\text{C}$, $V_{DD} = 3\text{V}$, $V_{SS} = 0\text{V}$, $C_{REG} = 10\ \mu\text{F}$, $C_{BST} = 10\ \mu\text{F}$, 9VDET low, ACDET low. (Note 1) (Note 2) (Note 3)

Parameter	Symbol	Test Pin	Min.	Typ.	Max.	Units	Conditions
Output Voltage High	V_{OH1}	18, 19	9.5	—	—	V	HS or HB; $I_{OUT} = -16\ \text{mA}$; $V_{BST} = 10\text{V}$; $HRNEN = V_{REG}$
	V_{OHIO1}	9	3	—	—	V	IO1, $I_{OUT} = -4\ \text{mA}$, $IODIR = V_{IH1}$, $IO2 = V_{IH1}$
	V_{OHIO2}	10	$V_{REG} - .5$	—	—	V	IO2, $I_{OUT} = -100\ \mu\text{A}$, $IODIR = V_{SS}$, $IO1 = V_{IHIO1}$
Reference Voltage	V_{REF}	3	—	300	—	mV	
V_{BST} Output Voltage	V_{VO1}	13	9	9.8	10.6	V	$V_{DD} = 3\text{V}$; $HRNEN = V_{REG}$; $I_{OUT} = 10\ \text{mA}$
	V_{VO2}	13	3.6	4	4.4	V	$V_{DD} = 3\text{V}$; $HRNEN = V_{SS}$; $I_{OUT} = 10\ \text{mA}$
V_{BST} Efficiency	V_{EFF1}		—	85	—	%	$I_{LOAD} = 10\ \text{mA}$; $V_{DD} = 3\text{V}$; $HRNEN = V_{SS}$
	V_{EFF2}		—	75	—	%	$I_{LOAD} = 100\ \mu\text{A}$; $V_{DD} = 3\text{V}$; $HRNEN = V_{SS}$
V_{REG} Voltage	V_{REG}	12	3.2	3.3	3.4	V	$I_{OUT} < 20\ \text{mA}$
V_{REG} Load Regulation	V_{REGLD}	12	—	30	50	mV	$I_{OUT} = 0$ to $20\ \text{mA}$; $HRNEN = V_{REG}$
Brown-out Threshold	V_{OBVT}	13	3.2	3.6	4	V	Falling edge of V_{BST}
V_{BST} -to-Brown-out Margin	V_{OBVTM}	13	100	400	—	mV	$V_{VO2} - V_{OBVT}$
Brown-out Pull Down	I_{BT}	12	20	40	—	mA	$V_{BST} = 3.0\text{V}$; $V_{REG} = 2.0\text{V}$
V_{REG} Over Voltage Clamp	V_{CL}	12	3.75	4	4.25	V	
IO1 Output Current	$IO1_{IH1}$	9	25	—	60	μA	$IODIR = V_{SS}$, $IO1 = 1\text{V}$
	$IO1_{IH2}$	9	—	—	150	μA	$IODIR = V_{SS}$, $IO1 = 15\text{V}$
	$IO1_{IOH1}$	9	-4	-5	—	mA	$IODIR$, $IO2 = V_{IH1}$, $IO1 = 3\text{V}$
	$IO1_{IOH2}$	9	—	-5	-16	mA	$IODIR$, $IO2 = V_{IH1}$, $IO1 = V_{SS}$
	$IO1_{IOL1}$	9	—	10	—	mA	IO Dump Current, $IODIR = V_{IH1}$, $IO2 = V_{SS}$, $IO1 = 1\text{V}$
IO1 Hysteresis	$V_{HYSTIO1}$	9	—	150	—	mV	$IODIR = V_{SS}$
Op Amp							
Input Offset Voltage	V_{OS}	4	-1	—	1	mV	$V_{CM} = 0.3\text{V}$
Common Mode Input Range	V_{CMR}	1, 2	V_{SS}	—	V_{REG}	V	

Note 1: Wherever a specific V_{BST} value is listed under test conditions, the V_{BST} is forced externally with the inductor disconnected and the boost regulator is NOT running.

2: Typical values are for design information only.

3: The limits shown are 100% tested at 25°C only. Test limits are guard-banded based on temperature characterization to warrant compliance at temperature extremes.

4: The Standby Supply Current $I_{DDSTBY1}$ specified above can be approximated as follows:

$$I_{DDSTBY1} = I_{DDQ} + I_{IND}$$

Where I_{DDQ} = average current into V_{DD} supply

I_{IND} = average inductor current = $V_{BST} * I_{VOQ} / (V_{IN} * \text{Efficiency})$

$V_{IN} = V_{DD} = 3\text{V}$

RE46C800

DC ELECTRICAL CHARACTERISTICS – RE46C800 (CONTINUED)

Unless otherwise indicated, all parameters apply at $T_A = -10^\circ\text{C}$ to $+60^\circ\text{C}$, $V_{DD} = 3\text{V}$, $V_{SS} = 0\text{V}$, $C_{REG} = 10\ \mu\text{F}$, $C_{BST} = 10\ \mu\text{F}$, 9VDET low, ACDET low. (Note 1) (Note 2) (Note 3)

Parameter	Symbol	Test Pin	Min.	Typ.	Max.	Units	Conditions
Common Mode Rejection Ratio	CMRR	1, 2, 4	—	80	—	dB	$V_{REG} = 3.3\text{V}$, $V_{CM} = -0.3\text{V}$ to 3.3V
DC Open-Loop Gain (large signal)	A_{OL}	4	—	115	—	dB	$R_L = 50\ \text{k}\Omega$, $V_{OUT} = 0.3\text{V}$ to $V_{REG} - 0.3\text{V}$
Maximum Output Voltage Swing	V_{OL} , V_{OH}	4	$V_{SS} + 10$	—	$V_{REG} - 10$	mV	$R_L = 50\ \text{k}\Omega$, 0.5V input overdrive
Output Short Circuit Current	I_{SC}	4	—	20	—	mA	$V_{REG} = 3.3\text{V}$

- Note 1:** Wherever a specific V_{BST} value is listed under test conditions, the V_{BST} is forced externally with the inductor disconnected and the boost regulator is NOT running.
- Note 2:** Typical values are for design information only.
- Note 3:** The limits shown are 100% tested at 25°C only. Test limits are guard-banded based on temperature characterization to warrant compliance at temperature extremes.
- Note 4:** The Standby Supply Current $I_{DDSTBY1}$ specified above can be approximated as follows:

$$I_{DDSTBY1} = I_{DDQ} + I_{IND}$$

Where I_{DDQ} = average current into V_{DD} supply

$$I_{IND} = \text{average inductor current} = V_{BST} * I_{VOQ} / (V_{IN} * \text{Efficiency})$$

$$V_{IN} = V_{DD} = 3\text{V}$$

AC ELECTRICAL CHARACTERISTICS

Unless otherwise indicated, all parameters apply at $T_A = -10^\circ\text{C}$ to $+60^\circ\text{C}$, $V_{DD} = 3\text{V}$, $V_{SS} = 0\text{V}$, $C_{REG} = 10\ \mu\text{F}$, $C_{VBST} = 10\ \mu\text{F}$.

Parameter	Symbol	Test Pin	Min.	Typ.	Max.	Units	Conditions
OP Amp AC Response							
Gain Bandwidth Product	GBWP	4	—	10	—	kHz	
Slew Rate	SR	4	—	3	—	V/ms	
Phase margin	PM	4	—	65	—	°	G = +1V/V
Op Amp Noise							
Input Voltage Noise	E_{ni}	1, 2	—	5	—	$\mu\text{V}_{\text{P-P}}$	f = 0.1 Hz to 10 kHz
Input Voltage Noise Density	e_{ni}	1, 2	—	170	—	nV/ $\sqrt{\text{Hz}}$	f = 1 kHz
Input Current Noise Density	i_{ni}	1, 2	—	0.6	—	fA/ $\sqrt{\text{Hz}}$	f = 1 kHz

- Note** 1: Wherever a specific V_{BST} value is listed under test conditions, the V_{BST} is forced externally with the inductor disconnected and the boost regulator is NOT running.
- 2: Typical values are for design information only.
- 3: The limits shown are 100% tested at 25°C only. Test limits are guard-banded based on temperature characterization to warrant compliance at temperature extremes.

TEMPERATURE CHARACTERISTICS

Electrical Characteristics: Unless otherwise indicated, $V_{DD} = 3\text{V}$, $V_{SS} = 0\text{V}$

Parameter	Sym.	Min.	Typ.	Max.	Units	Conditions
Temperature Ranges						
Operating Temperature Range	T_A	-10	—	60	°C	
Storage Temperature Range	T_{STG}	-55	—	125	°C	
Thermal Package Resistances						
Thermal Resistance, 20L-SSOP	θ_{JA}	—	87.3	—	°C/W	

RE46C800

2.0 PIN DESCRIPTIONS

The descriptions of the pins are listed in [Table 2-1](#).

TABLE 2-1: PIN FUNCTION TABLE

RE46C800	Symbol	Description
SSOP		
1	INP	Noninverting input of the op amp.
2	INN	Inverting input of the op amp.
3	V _{REF}	Voltage reference for CO biasing and detection circuitry.
4	OPOUT	Output of the op amp.
5	9VDET	Logic input used to disable the boost regulator.
6	V _{DD}	Low-voltage supply input.
7	ACDET	AC power detect pin.
8	LEDEN	Logic input used to enable the LED driver. Input is designed to interface with circuitry supplied by V _{REG} , so input voltage levels will scale with the V _{REG} voltage.
9	IO1	Logic bidirectional pin used for connection to remote units. This pin has an internal pull-down device. If used as an output, high level is VVO1.
10	IO2	Bidirectional pin used to send and receive IO1 interconnect signal status.
11	IODIR	Logic input used to select IO direction.
12	V _{REG}	Regulated output voltage. Nominal output is 3.3V.
13	V _{BST}	Boost regulator output, typically output voltage is 4V or 9.8V. Also used as the high-voltage supply input.
14	LEDPWR	Open drain NMOS output used to drive a visible LED.
15	LX	Open drain NMOS output used to drive the boost regulator inductor. The inductor should be connected from this pin to the positive supply through a low resistance path.
16	V _{SS}	Connect to the negative supply voltage.
17	FEED	Usually connected to the feedback electrode of the piezoelectric horn through a current limiting resistor. If not used, this pin must be connected to V _{SS} .
18	HS	HS is a complementary output to HB and connects to the ceramic electrode (S) of the piezoelectric transducer.
19	HB	This pin is connected to the metal electrode (B) of a piezoelectric transducer.
20	HRNEN	Logic input for horn enable designed to interface with circuitry supplied by V _{REG} . Input voltage levels will scale with the V _{REG} voltage.

3.0 DEVICE DESCRIPTION

3.1 Introduction

The RE46C800 provides the necessary analog functions to build a microcontroller-based CO or toxic gas detector. This includes an op amp and voltage reference for the electrochemical sensor, a voltage regulator for the microcontroller, an LED driver, a horn driver, a detector interconnect function, a boost regulator for 3V operation, and a power management system that allows operation from 3V, 9V or AC derived power. The power management system provides the capability for AC power with battery backup. The RE46C800 provides a simple means for the microcontroller to control the operation of the CO detector and provide the necessary signaling functions during an alarm condition.

3.2 Power Management System

The power management system allows the RE46C800 to be powered from a 3V or 9V battery or AC power. AC power is supplied as a DC voltage derived from an AC power supply. This DC voltage is diode connected to the V_{BST} pin of the RE46C800. AC supplied power and a 9V battery can both be diode connected to the V_{BST} pin.

For low-voltage systems the battery is connected to the V_{DD} pin. When only a low-voltage battery is available, the internal circuitry is powered from V_{DD} . When a 9V battery or AC power is available, the internal circuitry is powered from V_{REG} , which is a regulated 3.3V. The selection of the power source for the internal circuitry is controlled with the ACDET pin when the 9VDET pin is low.

In low-voltage systems that are also AC powered, the boost regulator will turn on if voltage of the AC supplied power drops below the specified boost regulator voltage. This can cause the low-voltage battery to discharge more rapidly than expected.

The 9VDET pin will disable the boost regulator if 9VDET is high. For a low-voltage system, the 9VDET pin should be connected to V_{SS} which will enable the boost regulator.

Table 3-1 shows the truth table for the power management system.

TABLE 3-1: POWER MANAGEMENT SYSTEM

9VDET	ACDET	Internal Supply	Boost Regulator
0	0	V_{DD}	Enabled
0	1	V_{REG}	Enabled
1	0	V_{REG}	Disabled
1	1	V_{REG}	Disabled

3.3 Boost Regulator

The boost regulator only operates in low-voltage applications. The boost regulator is a fixed off time boost regulator with peak current limiting. In low-boost operation the peak current is nominally 0.6A. In high-boost operation the peak current is nominally 1.2A. The boost regulator normally operates in Low-Boost mode, which provides a nominal 4V output voltage on the V_{BST} pin. In High-Boost mode, the boost regulator provides a nominal 9.8V on the V_{BST} pin. The boost regulator can be placed in High-Boost mode with HORNEN, LEDEN, or IODIR and IO2 both asserted high.

The brown-out threshold voltage is the V_{BST} voltage at which the voltage regulator and the horn will be disabled. When the V_{BST} voltage falls below the brown-out threshold voltage of 3.6V, V_{REG} will be disabled and pulled to V_{SS} with a nominal 40 mA current. When the boost voltage rises above the brown-out threshold voltage, V_{REG} is enabled.

3.4 Voltage Regulator

The voltage regulator provides a nominal 3.3V output at the V_{REG} pin and is intended to power a microcontroller. In normal operation, the regulator will source current up to 20 mA, but the current sinking capability is typically under 1 μ A. The voltage regulator is powered from the V_{BST} pin. In low-voltage applications the regulator is powered by the boost regulator and the regulator load current is part of the boost regulator load current. An overvoltage clamp is intended to limit the voltage at V_{REG} if it is pulled up by an external source to greater than 4V. When the boost regulator experiences a brown-out condition, the voltage regulator will be disabled and the V_{REG} output will be pulled to V_{SS} .

RE46C800

3.5 LED Driver

The LED drive circuit provides power to an LED, which can be used as a visual indicator by the system. The LED drive circuit can also be used as part of a battery check function in battery-powered applications. When LEDEN is asserted high the LED will load the V_{BST} output and the microcontroller can monitor the battery operation under load. In low-voltage systems the boost regulator will be placed into high-boost operation when LEDEN is asserted high. The load current is set by the resistor in series with the LED.

3.6 Interconnect Operation

The IO circuitry provides the means for the CO detector to be connected to other CO detectors or smoke alarms. Table 3-2 below provides the truth table for the interconnect circuit operation. IO1 is a bidirectional pin that connects to other CO detectors or smoke alarms. IO2 is a bidirectional pin that connects to the microcontroller. IODIR connects to the microcontroller and determines when IO1 and IO2 act as an input or output. When IO1 is used as an output asserting a logic high, the IO1 output acts as current source that is biased from V_{BST} . In low-voltage applications where the boost regulator is enabled, the boost regulator will operate in High-Boost mode. When IO1 is used as an output asserting a logic low, the IO1 output acts as current sink. IO2 logic levels are referenced to V_{REG} .

TABLE 3-2: INTERCONNECT LOGIC TRUTH TABLE

IODIR	IO2		IO1	
	Input	Output	Input	Output
1	0	—	—	0
1	1	—	—	1
0	—	0	0	—
0	—	1	1	—

3.7 CO Sensor Circuit

The RE46C800 provides a low offset op amp and reference voltage, V_{REF} , for a two terminal electrochemical CO or toxic gas sensor. The unity gain stable op amp provides rail-to-rail inputs and output. The op amp output is monitored by the microcontroller to determine the CO concentration. This uncommitted op amp can be used for other purposes such as temperature sensing.

4.0 APPLICATION NOTES

4.1 Boost Regulator

The boost regulator in High-Boost mode (nominal $V_{BST} = 9.8V$) can draw current pulses of greater than 1A and is, therefore, very sensitive to series resistance. Critical components of this resistance are: the inductor DC resistance, the internal resistance of the battery and the resistance in the connections from the inductor to the battery, from the inductor to the LX pin, from the inductor through the boost capacitor, and from the V_{SS} pin to the battery. In order to function properly under full load at $V_{DD} = 2V$, the total of the inductor and interconnect resistances should not exceed 0.3Ω . The internal battery resistance should be no more than 0.5Ω and a low ESR capacitor of $10\mu F$ or more should be connected in parallel with the battery to average the current draw over the boost regulator switching cycle. The Schottky diode and inductor should be specified with a maximum operating current of 1.5A or higher. The boost capacitor should have a low ESR.

4.2 Typical Applications

A few typical applications using the RE46C800 are listed below:

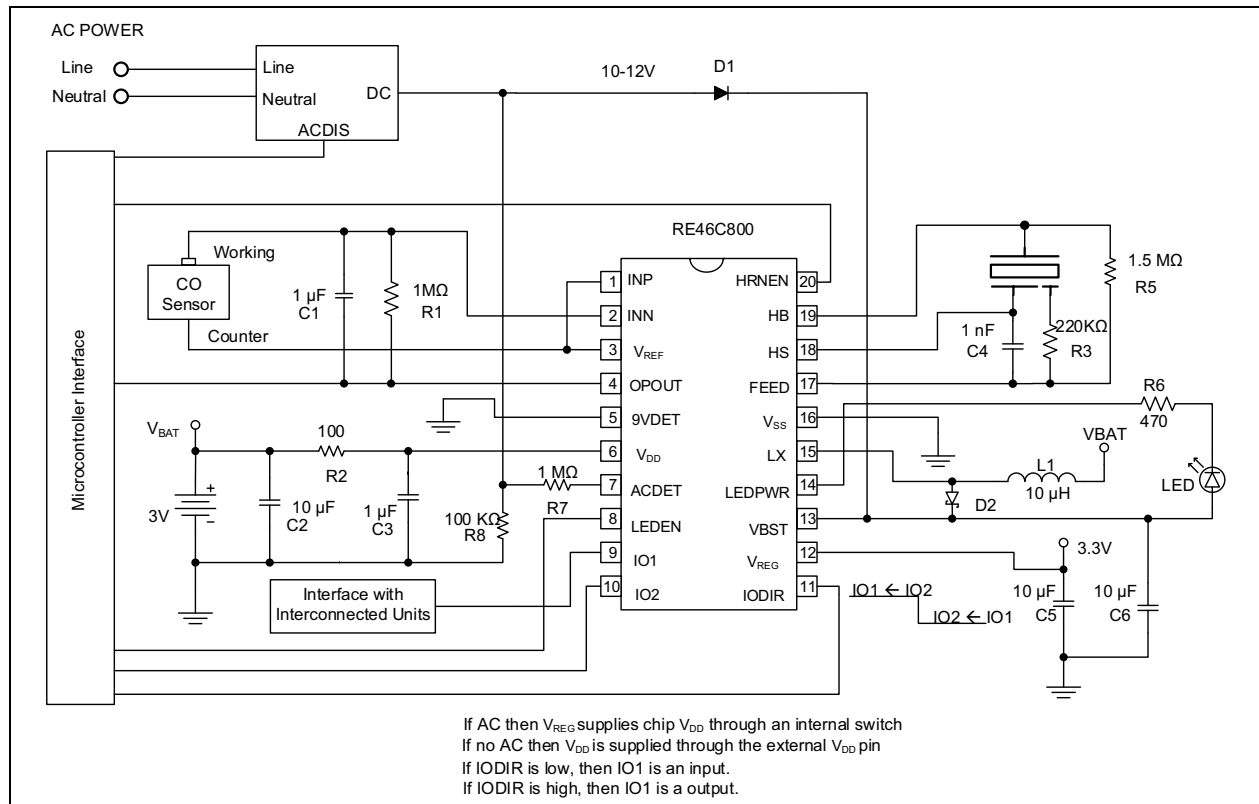

FIGURE 4-1: Typical Application: AC with 3V Battery Backup.

RE46C800

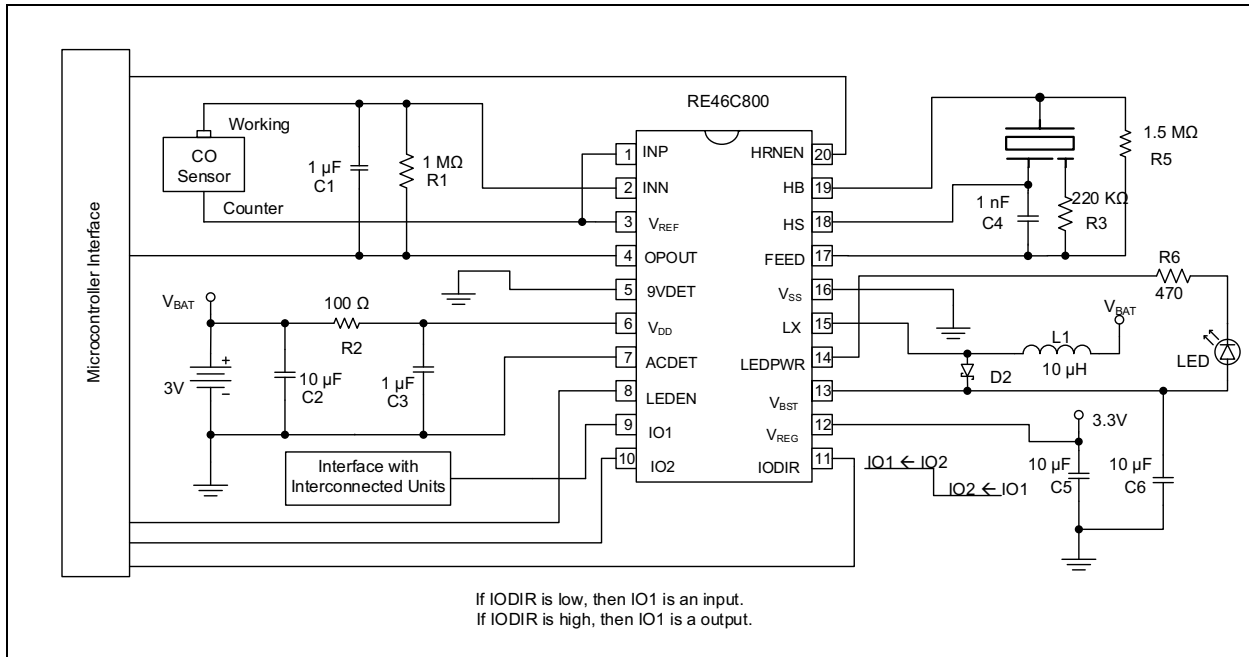

FIGURE 4-2: Typical Application: 3V Battery Operation.

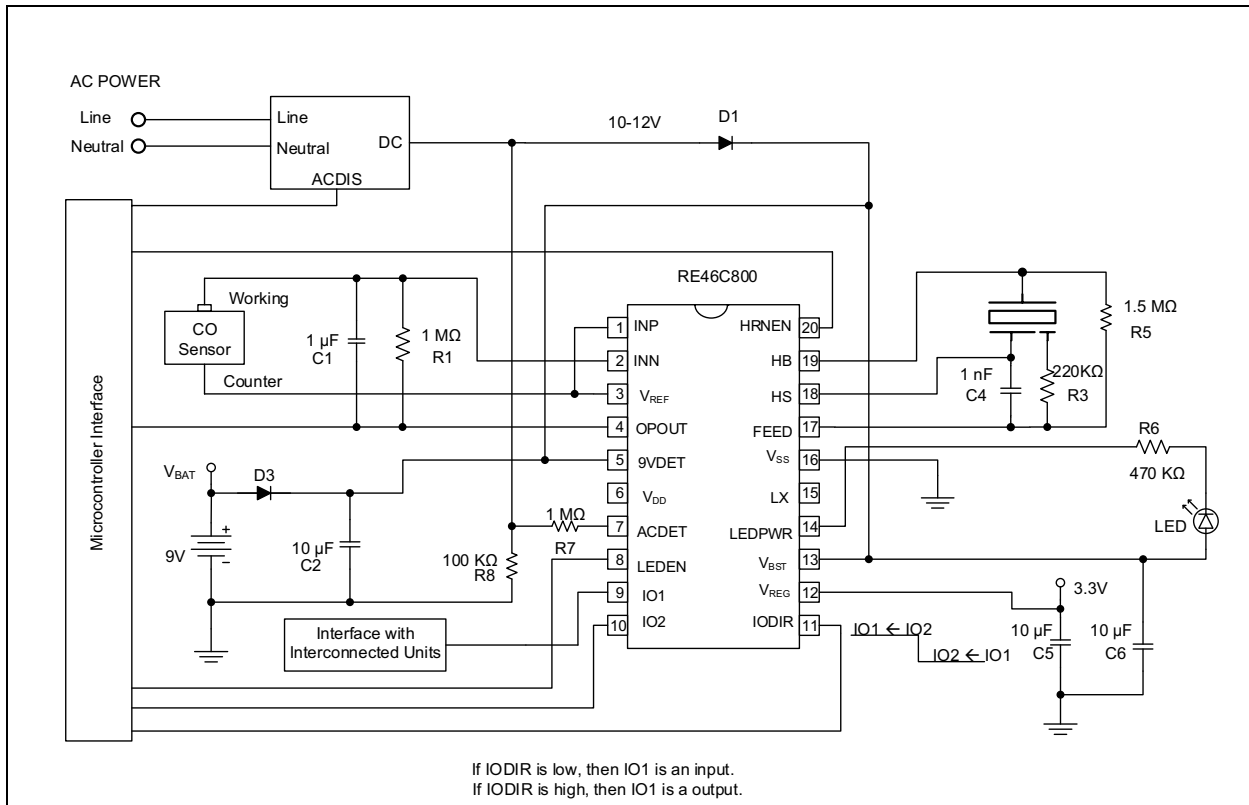

FIGURE 4-3: Typical Application: AC with 9V Battery Backup.

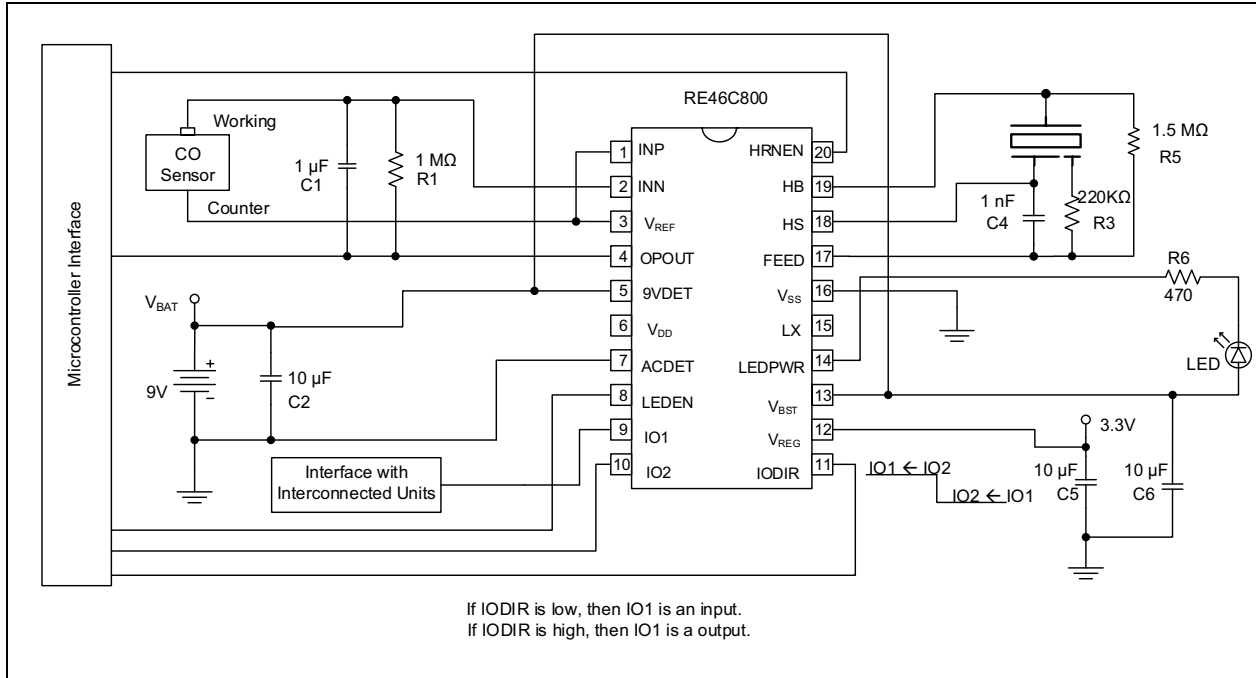

FIGURE 4-4: Typical Application: 9V Battery Operation.

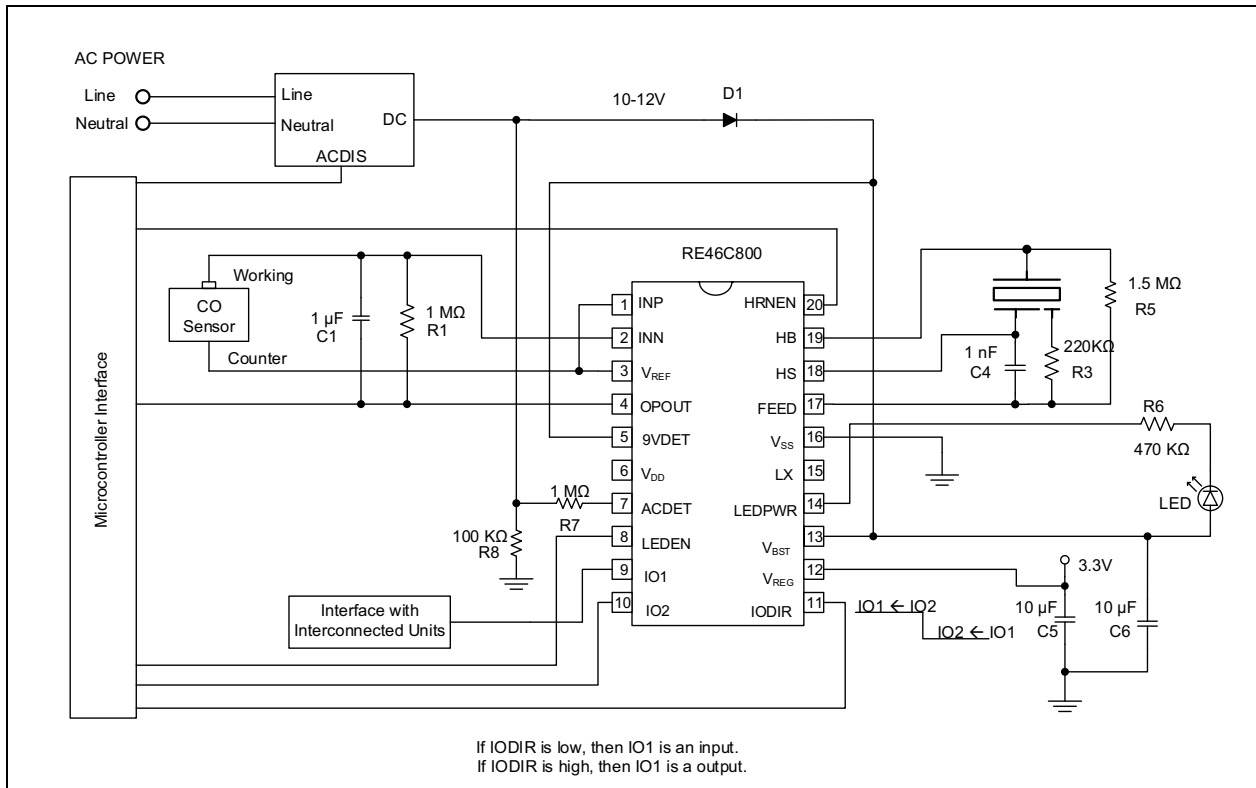

FIGURE 4-5: Typical Application: AC only.

RE46C800

NOTES:

5.0 PACKAGING INFORMATION

5.1 Package Marking Information

20-Lead SSOP (5.30 mm)

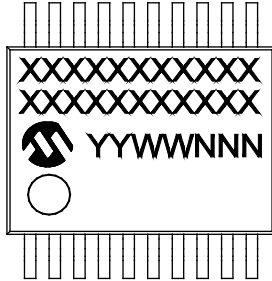

Example

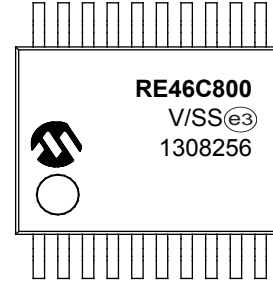

Legend:	XX...X	Customer-specific information
	Y	Year code (last digit of calendar year)
	YY	Year code (last 2 digits of calendar year)
	WW	Week code (week of January 1 is week '01')
	NNN	Alphanumeric traceability code
	(e3)	Pb-free JEDEC designator for Matte Tin (Sn)
	*	This package is Pb-free. The Pb-free JEDEC designator (e3) can be found on the outer packaging for this package.

Note: In the event the full Microchip part number cannot be marked on one line, it will be carried over to the next line, thus limiting the number of available characters for customer-specific information.

RE46C800

20-Lead Plastic Shrink Small Outline (SS) – 5.30 mm Body [SSOP]

Note: For the most current package drawings, please see the Microchip Packaging Specification located at <http://www.microchip.com/packaging>

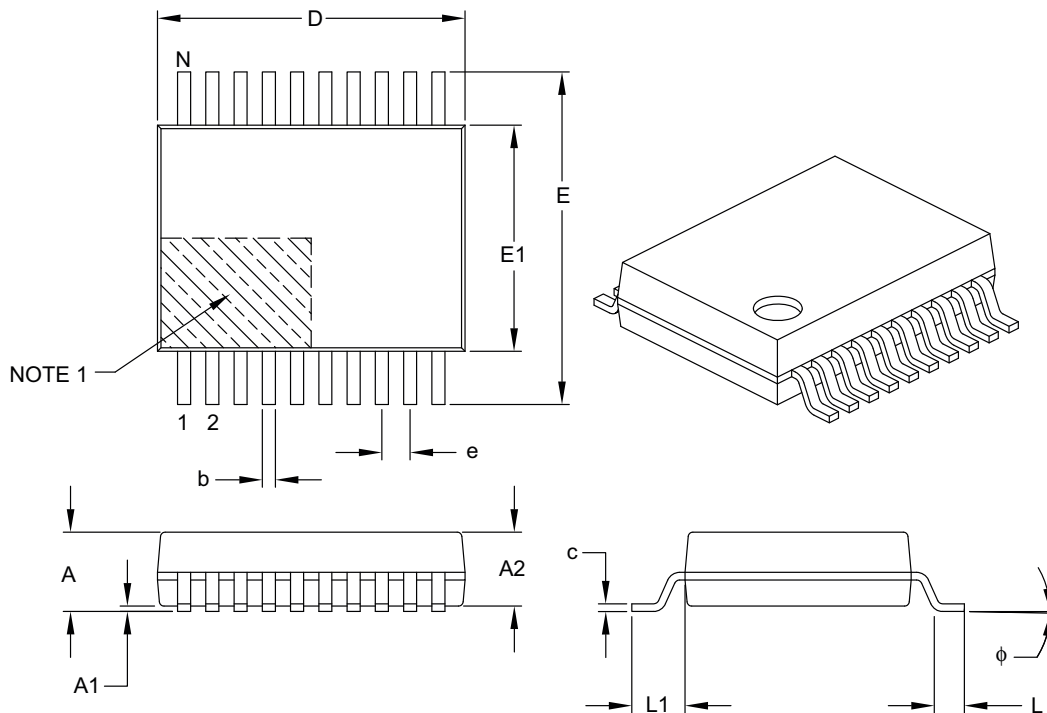

		Units	MILLIMETERS		
Dimension Limits			MIN	NOM	MAX
Number of Pins	N		20		
Pitch	e		0.65 BSC		
Overall Height	A	–	–	–	2.00
Molded Package Thickness	A2		1.65	1.75	1.85
Standoff	A1		0.05	–	–
Overall Width	E		7.40	7.80	8.20
Molded Package Width	E1		5.00	5.30	5.60
Overall Length	D		6.90	7.20	7.50
Foot Length	L		0.55	0.75	0.95
Footprint	L1		1.25 REF		
Lead Thickness	c		0.09	–	0.25
Foot Angle	ϕ		0°	4°	8°
Lead Width	b		0.22	–	0.38

Notes:

- Pin 1 visual index feature may vary, but must be located within the hatched area.
- Dimensions D and E1 do not include mold flash or protrusions. Mold flash or protrusions shall not exceed 0.20 mm per side.
- Dimensioning and tolerancing per ASME Y14.5M.

BSC: Basic Dimension. Theoretically exact value shown without tolerances.

REF: Reference Dimension, usually without tolerance, for information purposes only.

Microchip Technology Drawing C04-072B

20-Lead Plastic Shrink Small Outline (SS) - 5.30 mm Body [SSOP]

Note: For the most current package drawings, please see the Microchip Packaging Specification located at <http://www.microchip.com/packaging>

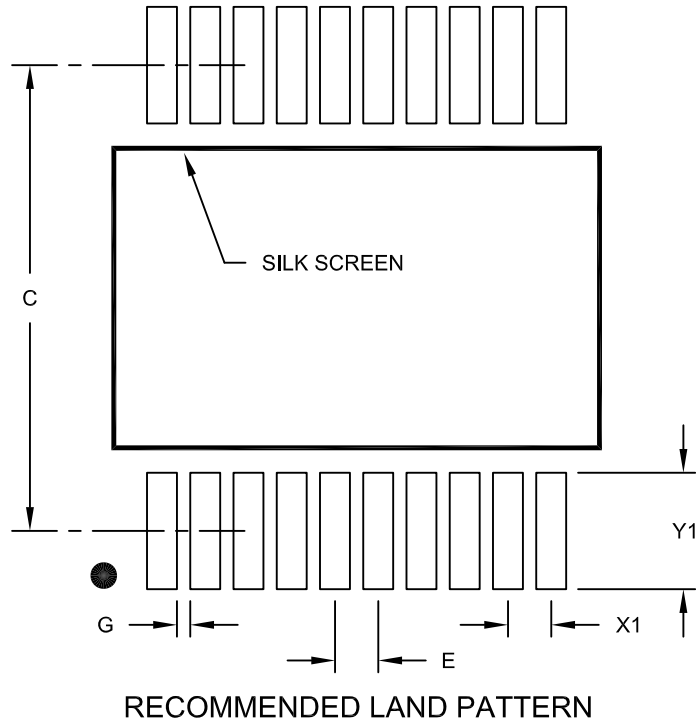

Dimension Limits	Units	MILLIMETERS		
		MIN	NOM	MAX
Contact Pitch	E	0.65 BSC		
Contact Pad Spacing	C		7.20	
Contact Pad Width (X20)	X1			0.45
Contact Pad Length (X20)	Y1			1.75
Distance Between Pads	G	0.20		

Notes:

1. Dimensioning and tolerancing per ASME Y14.5M

BSC: Basic Dimension. Theoretically exact value shown without tolerances.

Microchip Technology Drawing No. C04-2072A

RE46C800

NOTES:

APPENDIX A: REVISION HISTORY

Revision D (June 2019)

The following is the list of modifications:

- Updated the title of the document.
- Updated **Section 3.7 “CO Sensor Circuit”**.

Revision C (October 2017)

The following is the list of modifications:

- Updated [Figure 4-2](#).
- Various typographical edits.

Revision B (July 2013)

The following is the list of modifications.

- Removed the lead free designation in part ordering number in the [Product Identification System](#) section.

Revision A (March 2013)

- Initial Release of this Document.

RE46C800

NOTES:

PRODUCT IDENTIFICATION SYSTEM

To order or obtain information, e.g., on pricing or delivery, refer to the factory or the listed sales office.

<u>PART NO.</u>	X	X
Device	Package	Number of Pins
Device:	RE46C800	CMOS Carbon Monoxide Detector IC
	RE46C318T	CMOS Carbon Monoxide Detector IC (Tape and Reel)
Package:	SS20 = Plastic Shrink Small Outline - Narrow, 5.33 mm Body, 20-Lead (SSOP)	

Examples:

- a) RE46C800SS20: 20LD SSOP package
- b) RE46C800SS20T: 20LD SSOP package
Tape and Reel

RE46C800

NOTES:

Note the following details of the code protection feature on Microchip devices:

- Microchip products meet the specification contained in their particular Microchip Data Sheet.
- Microchip believes that its family of products is one of the most secure families of its kind on the market today, when used in the intended manner and under normal conditions.
- There are dishonest and possibly illegal methods used to breach the code protection feature. All of these methods, to our knowledge, require using the Microchip products in a manner outside the operating specifications contained in Microchip's Data Sheets. Most likely, the person doing so is engaged in theft of intellectual property.
- Microchip is willing to work with the customer who is concerned about the integrity of their code.
- Neither Microchip nor any other semiconductor manufacturer can guarantee the security of their code. Code protection does not mean that we are guaranteeing the product as “unbreakable.”

Code protection is constantly evolving. We at Microchip are committed to continuously improving the code protection features of our products. Attempts to break Microchip's code protection feature may be a violation of the Digital Millennium Copyright Act. If such acts allow unauthorized access to your software or other copyrighted work, you may have a right to sue for relief under that Act.

Information contained in this publication regarding device applications and the like is provided only for your convenience and may be superseded by updates. It is your responsibility to ensure that your application meets with your specifications. MICROCHIP MAKES NO REPRESENTATIONS OR WARRANTIES OF ANY KIND WHETHER EXPRESS OR IMPLIED, WRITTEN OR ORAL, STATUTORY OR OTHERWISE, RELATED TO THE INFORMATION, INCLUDING BUT NOT LIMITED TO ITS CONDITION, QUALITY, PERFORMANCE, MERCHANTABILITY OR FITNESS FOR PURPOSE. Microchip disclaims all liability arising from this information and its use. Use of Microchip devices in life support and/or safety applications is entirely at the buyer's risk, and the buyer agrees to defend, indemnify and hold harmless Microchip from any and all damages, claims, suits, or expenses resulting from such use. No licenses are conveyed, implicitly or otherwise, under any Microchip intellectual property rights unless otherwise stated.

Trademarks

The Microchip name and logo, the Microchip logo, Adaptec, AnyRate, AVR, AVR logo, AVR Freaks, BesTime, BitCloud, chipKIT, chipKIT logo, CryptoMemory, CryptoRF, dsPIC, FlashFlex, flexPWR, HELDO, IGLOO, JukeBlox, KeeLoq, Klear, LANCheck, LinkMD, maXStylus, maXTouch, MediaLB, megaAVR, Microsemi, Microsemi logo, MOST, MOST logo, MPLAB, OptoLyzer, PackeTime, PIC, picoPower, PICSTART, PIC32 logo, PolarFire, Prochip Designer, QTouch, SAM-BA, SenGenuity, SpyNIC, SST, SST Logo, SuperFlash, Symmetricom, SyncServer, Tachyon, TempTracker, TimeSource, tinyAVR, UNI/O, Vectron, and XMEGA are registered trademarks of Microchip Technology Incorporated in the U.S.A. and other countries.

APT, ClockWorks, The Embedded Control Solutions Company, EtherSynch, FlashTec, Hyper Speed Control, HyperLight Load, IntelliMOS, Libero, motorBench, mTouch, Powermite 3, Precision Edge, ProASIC, ProASIC Plus, ProASIC Plus logo, Quiet-Wire, SmartFusion, SyncWorld, Temux, TimeCesium, TimeHub, TimePictra, TimeProvider, Vite, WinPath, and ZL are registered trademarks of Microchip Technology Incorporated in the U.S.A.

Adjacent Key Suppression, AKS, Analog-for-the-Digital Age, Any Capacitor, AnyIn, AnyOut, BlueSky, BodyCom, CodeGuard, CryptoAuthentication, CryptoAutomotive, CryptoCompanion, CryptoController, dsPICDEM, dsPICDEM.net, Dynamic Average Matching, DAM, ECAN, EtherGREEN, In-Circuit Serial Programming, ICSP, INICnet, Inter-Chip Connectivity, JitterBlocker, KlearNet, KlearNet logo, memBrain, Mindi, MiWi, MPASM, MPF, MPLAB Certified logo, MPLIB, MPLINK, MultiTRAK, NetDetach, Omniscient Code Generation, PICDEM, PICDEM.net, PICKit, PICtail, PowerSmart, PureSilicon, QMatrix, REAL ICE, Ripple Blocker, SAM-ICE, Serial Quad I/O, SMART-I.S., SQI, SuperSwitcher, SuperSwitcher II, Total Endurance, TSHARC, USBCheck, VariSense, ViewSpan, WiperLock, Wireless DNA, and ZENA are trademarks of Microchip Technology Incorporated in the U.S.A. and other countries.

SQTP is a service mark of Microchip Technology Incorporated in the U.S.A.

The Adaptec logo, Frequency on Demand, Silicon Storage Technology, and Symmcom are registered trademarks of Microchip Technology Inc. in other countries.

GestIC is a registered trademark of Microchip Technology Germany II GmbH & Co. KG, a subsidiary of Microchip Technology Inc., in other countries.

All other trademarks mentioned herein are property of their respective companies.

© 2013 - 2019, Microchip Technology Incorporated, All Rights Reserved.

ISBN: 978-1-5224-4583-8

For information regarding Microchip's Quality Management Systems, please visit www.microchip.com/quality.



MICROCHIP

Worldwide Sales and Service

AMERICAS

Corporate Office
2355 West Chandler Blvd.
Chandler, AZ 85224-6199
Tel: 480-792-7200
Fax: 480-792-7277
Technical Support:
<http://www.microchip.com/support>
Web Address:
www.microchip.com

Atlanta

Duluth, GA
Tel: 678-957-9614
Fax: 678-957-1455

Austin, TX

Tel: 512-257-3370

Boston

Westborough, MA
Tel: 774-760-0087
Fax: 774-760-0088

Chicago

Itasca, IL
Tel: 630-285-0071
Fax: 630-285-0075

Dallas

Addison, TX
Tel: 972-818-7423
Fax: 972-818-2924

Detroit

Novi, MI
Tel: 248-848-4000

Houston, TX

Tel: 281-894-5983

Indianapolis

Noblesville, IN
Tel: 317-773-8323
Fax: 317-773-5453
Tel: 317-536-2380

Los Angeles

Mission Viejo, CA
Tel: 949-462-9523
Fax: 949-462-9608
Tel: 951-273-7800

Raleigh, NC

Tel: 919-844-7510

New York, NY

Tel: 631-435-6000

San Jose, CA

Tel: 408-735-9110
Tel: 408-436-4270

Canada - Toronto

Tel: 905-695-1980
Fax: 905-695-2078

ASIA/PACIFIC

Australia - Sydney
Tel: 61-2-9868-6733

China - Beijing
Tel: 86-10-8569-7000

China - Chengdu
Tel: 86-28-8665-5511

China - Chongqing
Tel: 86-23-8980-9588

China - Dongguan
Tel: 86-769-8702-9880

China - Guangzhou
Tel: 86-20-8755-8029

China - Hangzhou
Tel: 86-571-8792-8115

China - Hong Kong SAR
Tel: 852-2943-5100

China - Nanjing
Tel: 86-25-8473-2460

China - Qingdao
Tel: 86-532-8502-7355

China - Shanghai
Tel: 86-21-3326-8000

China - Shenyang
Tel: 86-24-2334-2829

China - Shenzhen
Tel: 86-755-8864-2200

China - Suzhou
Tel: 86-186-6233-1526

China - Wuhan
Tel: 86-27-5980-5300

China - Xian
Tel: 86-29-8833-7252

China - Xiamen
Tel: 86-592-2388138

China - Zhuhai
Tel: 86-756-3210040

ASIA/PACIFIC

India - Bangalore
Tel: 91-80-3090-4444

India - New Delhi
Tel: 91-11-4160-8631

India - Pune
Tel: 91-20-4121-0141

Japan - Osaka
Tel: 81-6-6152-7160

Japan - Tokyo
Tel: 81-3-6880-3770

Korea - Daegu
Tel: 82-53-744-4301

Korea - Seoul
Tel: 82-2-554-7200

Malaysia - Kuala Lumpur
Tel: 60-3-7651-7906

Malaysia - Penang
Tel: 60-4-227-8870

Philippines - Manila
Tel: 63-2-634-9065

Singapore
Tel: 65-6334-8870

Taiwan - Hsin Chu
Tel: 886-3-577-8366

Taiwan - Kaohsiung
Tel: 886-7-213-7830

Taiwan - Taipei
Tel: 886-2-2508-8600

Thailand - Bangkok
Tel: 66-2-694-1351

Vietnam - Ho Chi Minh
Tel: 84-28-5448-2100

EUROPE

Austria - Wels
Tel: 43-7242-2244-39
Fax: 43-7242-2244-393

Denmark - Copenhagen
Tel: 45-4450-2828
Fax: 45-4485-2829

Finland - Espoo
Tel: 358-9-4520-820

France - Paris
Tel: 33-1-69-53-63-20
Fax: 33-1-69-30-90-79

Germany - Garching
Tel: 49-8931-9700

Germany - Haan
Tel: 49-2129-3766400

Germany - Heilbronn
Tel: 49-7131-72400

Germany - Karlsruhe
Tel: 49-721-625370

Germany - Munich
Tel: 49-89-627-144-0
Fax: 49-89-627-144-44

Germany - Rosenheim
Tel: 49-8031-354-560

Israel - Ra'anana
Tel: 972-9-744-7705

Italy - Milan
Tel: 39-0331-742611
Fax: 39-0331-466781

Italy - Padova
Tel: 39-049-7625286

Netherlands - Drunen
Tel: 31-416-690399
Fax: 31-416-690340

Norway - Trondheim
Tel: 47-7288-4388

Poland - Warsaw
Tel: 48-22-3325737

Romania - Bucharest
Tel: 40-21-407-87-50

Spain - Madrid
Tel: 34-91-708-08-90
Fax: 34-91-708-08-91

Sweden - Gothenberg
Tel: 46-31-704-60-40

Sweden - Stockholm
Tel: 46-8-5090-4654

UK - Wokingham
Tel: 44-118-921-5800
Fax: 44-118-921-5820