

THIS DRAWING IS UNPUBLISHED. RELEASED FOR PUBLICATION
 (C) COPYRIGHT 19 BY AMP INCORPORATED. ALL RIGHTS RESERVED.

LOC	DIST	REVISIONS			
P	LTR	DESCRIPTION	DATE	DWN	APVD
G	86	REV PER 063A-0561-01	07OCT02	JR	MS

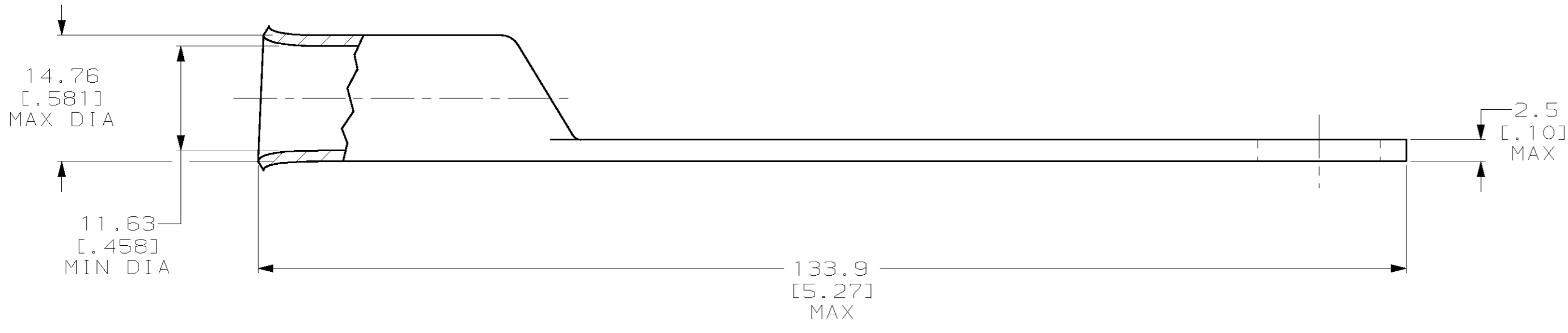
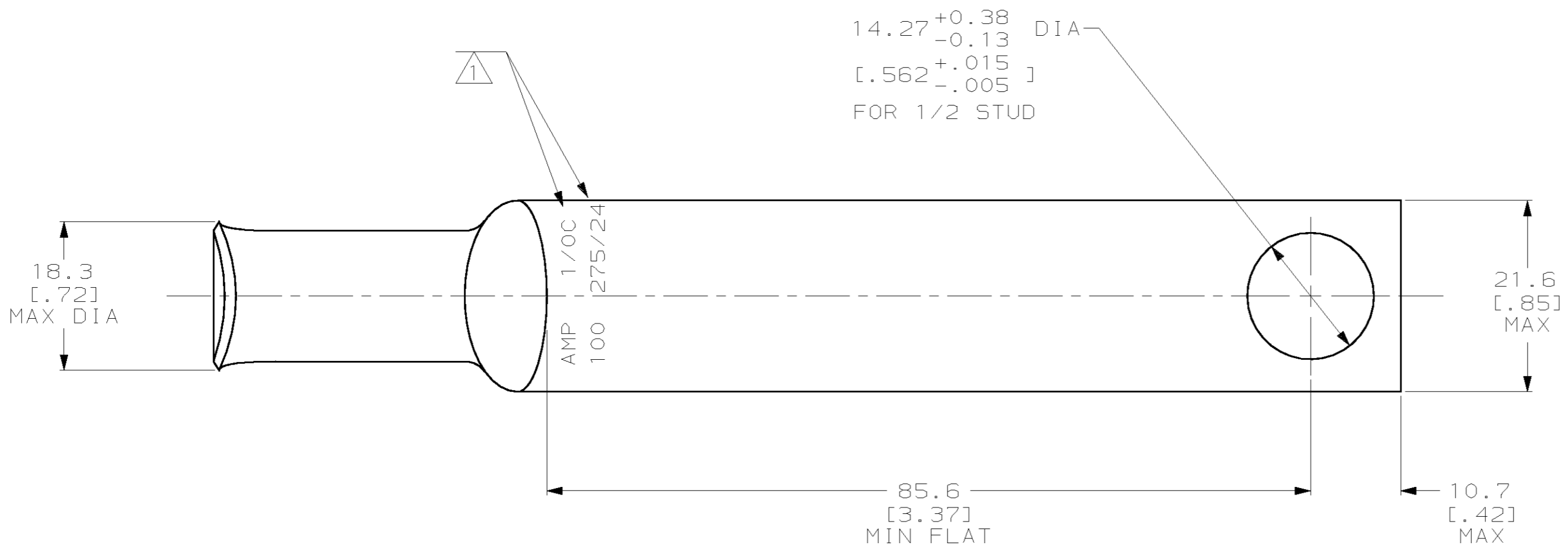

184130-1
 PART NUMBER

AMP INCORPORATED CUSTOMER SERVICE SYSTEMS		RECOMMENDED OPERATING TEMPERATURE: 170° MAX
FOR ADDITIONAL PRODUCT INFORMATION OR COPIES OF DRAWINGS AND TECHNICAL DOCUMENTS	PRODUCT INFORMATION CENTER 1-800-522-6752	VOLTAGE RATING: NOT APPLICABLE
FOR APPLICATION TOOLING INFORMATION	TOOLING ASSISTANCE CENTER 1-800-722-1111	WIRE CROSS SECTIONAL AREA RANGE: 42.4-60.5mm ² [83,700-119,500] CIR MILS SOLID OR STRANDED
FOR ORDER ENTRY	1-800-526-5142	

THIS DRAWING IS A CONTROLLED DOCUMENT FOR AMP INCORPORATED. IT IS SUBJECT TO CHANGE AND THE CONTROLLING ENGINEERING ORGANIZATION SHOULD BE CONTACTED FOR THE LATEST REVISION.		DWN DK SCHRUM 16MAR95	AMP Incorporated Harrisburg, PA 17105-3608	
DIMENSIONS: mm [INCHES]		CHK AJ KAUFMAN 17MAR95	NAME TERMINAL, AMPOWER, WIRE SIZE: 1/0 AWG	
TOLERANCES UNLESS OTHERWISE SPECIFIED: 0 PLC ±- 1 PLC ±- 2 PLC ±- 3 PLC ±- 4 PLC ±- ANGLES ±-		APVD JL MECKLEY 17MAR95	DRAWING NO C-184130	
MATERIAL COPPER PER ASTM B-75 ANNEALED	FINISH TIN PLATE 0.00381 [.000150] MIN THK PER MIL-T-10727	PRODUCT SPEC -	SIZE A2	CAGE CODE 00779
		APPLICATION SPEC -	WEIGHT -	SCALE 2:1
		CUSTOMER DRAWING	SHEET 1 OF 1	REV A

184130