

ISP762T

Smart power high-side-switch for industrial applications



Features

- Overload protection
- Current limitation
- Short circuit protection
- Thermal shutdown with restart
- Overvoltage protection (including load dump)
- Fast demagnetization of inductive loads
- Reverse battery protection with external resistor
- CMOS compatible input
- Loss of GND and loss of V_{bb} protection
- ESD-protection
- Very low standby current
- Green product (RoHS compliant)



Potential applications

- All types of resistive, inductive and capacitive loads
- μ C compatible power switch for 12 V and 24 V DC applications
- Replaces electromechanical relays and discrete circuits

Product validation

Qualified for industrial applications according to the relevant tests of JEDEC JESD47/20/22.

Description

Table 1 Product summary

Parameter	Symbol	Value	Unit
Overvoltage protection	$V_{bb(AZ)}$	41	V
Operating voltage	$V_{bb(on)}$	5 to 34	V
On-state resistance	R_{ON}	100	m Ω
Nominal load current	$I_{L(nom)}$	2	A

N channel vertical power FET with charge pump, ground referenced CMOS compatible input, monolithically integrated with embedded protective functions.

ISP762T
Smart power high-side-switch for industrial applications



Description

Type	Package	Marking
ISP762T	PG-DSO-8	I762T

Table of contents

	Features	1
	Potential applications	1
	Product validation	1
	Description	1
	Table of contents	3
1	Block diagram	4
2	Pin configuration	5
3	General product characteristics	6
3.1	Absolute maximum ratings	6
3.2	Thermal resistance	7
4	Functional description and electrical characteristics	8
4.1	Functional description	8
4.2	Electrical characteristics	10
4.3	Typical performance characteristics	12
4.4	Timing diagrams	17
5	Package information	18
6	Revision history	19
	Disclaimer	20

Block diagram

1 Block diagram

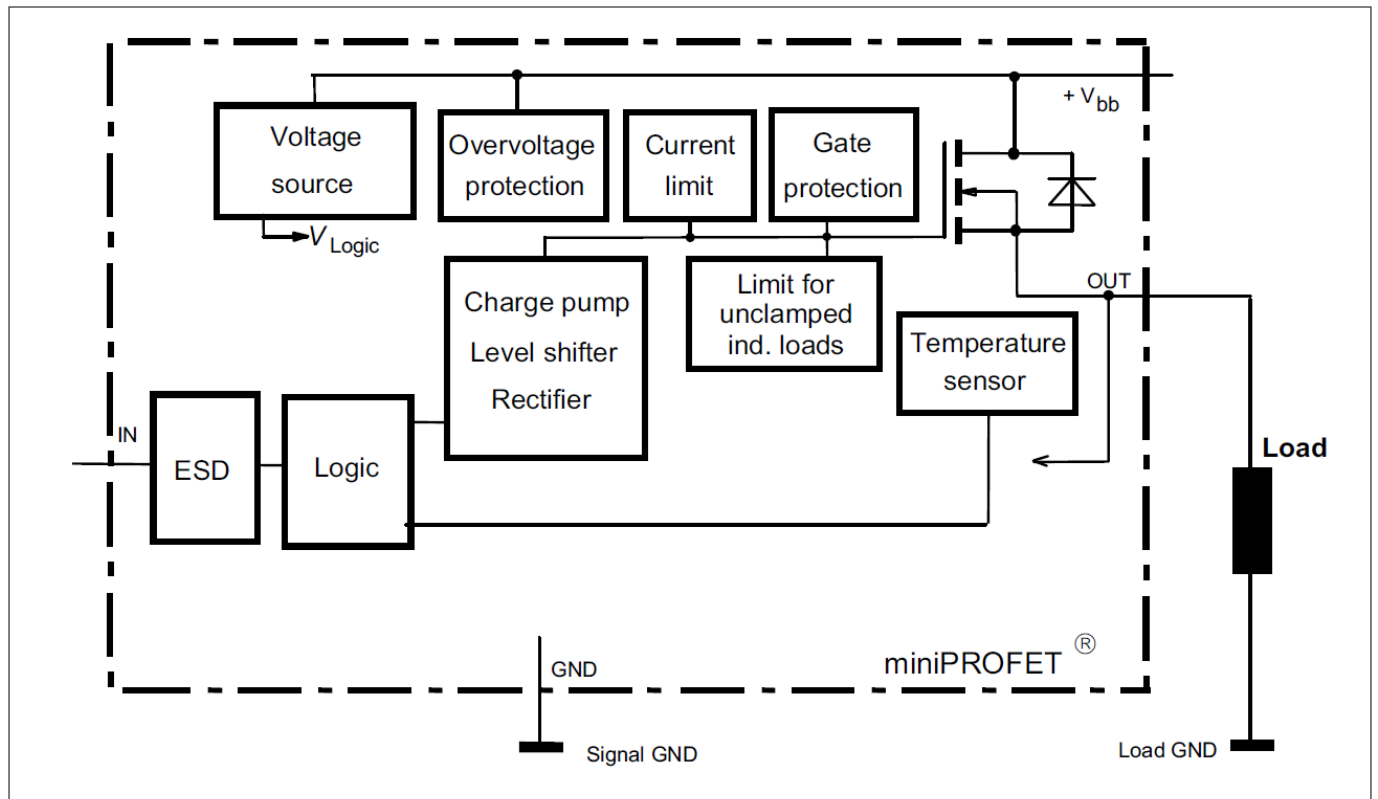

Figure 1 Block diagram

Pin configuration

2 Pin configuration

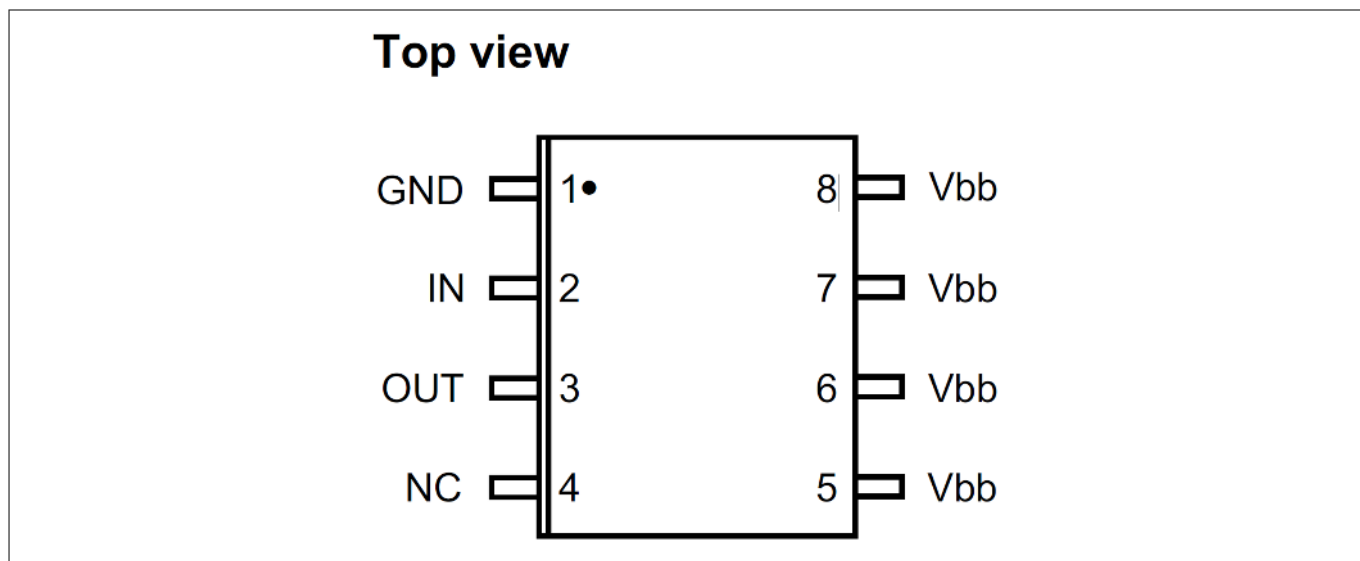

Figure 2 Pin configuration

Pin	Symbol	Function
1	GND	Logic ground
2	IN	Input, activates the power switch in case of logic high signal
3	OUT	Output to the load
4	NC	not connected
5	Vbb	Positive power supply voltage
6	Vbb	Positive power supply voltage
7	Vbb	Positive power supply voltage
8	Vbb	Positive power supply voltage

General product characteristics

3 General product characteristics

3.1 Absolute maximum ratings

Table 2 Maximum ratings

$T_j = 25^\circ\text{C}$, unless otherwise specified

Parameter	Symbol	Value	Unit	Note or condition
Supply voltage	V_{bb}	40	V	–
Supply voltage for full short circuit protection	$V_{bb(SC)}$	V_{bb}	V	$T_j = -40^\circ\text{C}$ to $+150^\circ\text{C}$
Continuous input voltage	V_{IN}	-10 to +16	V	–
Load current	I_L	self limited	A	short-circuit current, see p. 10
Current through input pin (DC)	I_{IN}	± 5	mA	–
Operating temperature	T_j	-40 to +150	$^\circ\text{C}$	–
Storage temperature	T_{stg}	-55 to +150	$^\circ\text{C}$	–
Power dissipation	P_{tot}	1.5	W	1)
Inductive load switch-off energy dissipation	E_{AS}	870	mJ	1) 2) single pulse, (see page 9) $T_j = 150^\circ\text{C}$, $V_{bb} = 13.5\text{ V}$, $I_L = 1\text{ A}$
Load dump protection	$V_{LoadDump}$	60	V	2) 3) $V_{LoadDump} = V_A + V_S$ $R_1 = 2\ \Omega$, $t_d = 400\text{ ms}$, $V_{IN} = \text{low or high}$, $V_A = 13.5\text{ V}$, $R_L = 13.5\ \Omega$
Electrostatic Discharge Voltage (Human Body Model)	V_{ESD}		kV	according to ANSI/ESDA/JEDEC JS001 (1.5 k Ω , 100 pF)
OUT		± 6		
IN		± 1		
all other pins		± 3		

¹ Device on 50 mm × 50 mm × 1.5 mm epoxy PCB FR4 with 6 cm² (one layer, 70 μm thick) copper area for drain connection. PCB is vertical without blown air. (see page [18](#))

² Not subject to production test, specified by design

³ $V_{LoadDump}$ is set up without the DUT connected to the generator per ISO 7637-1 and DIN 40839. Supply voltages higher than $V_{bb(AZ)}$ require an external current limit for the GND pin, e.g. with a 150 Ω resistor in GND connection. A resistor for the protection of the input is integrated.

General product characteristics

3.2 Thermal resistance

Table 3 Thermal resistance

Parameter	Symbol	Values			Unit	Note or condition
		Min.	Typ.	Max.		
Thermal resistance minimum footprint 6 cm ² cooling area ⁴⁾	$R_{th(JA)}$	–	95 70	– 83	K/W	–

⁴⁾ Device on 50 mm × 50 mm × 1.5 mm epoxy PCB FR4 with 6 cm² (one layer, 70 μm thick) copper area for drain connection. PCB is vertical without blown air. (see page 18)

Functional description and electrical characteristics

4 Functional description and electrical characteristics

4.1 Functional description

Terms

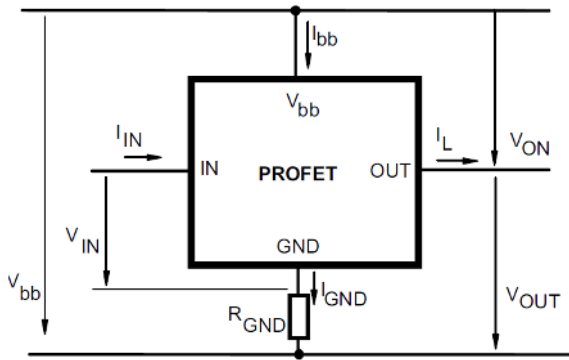

Inductive and overvoltage output clamp

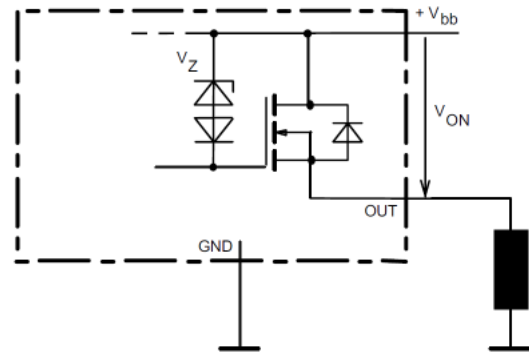

V_{ON} clamped to 47 V typ.

Input circuit (ESD protection)

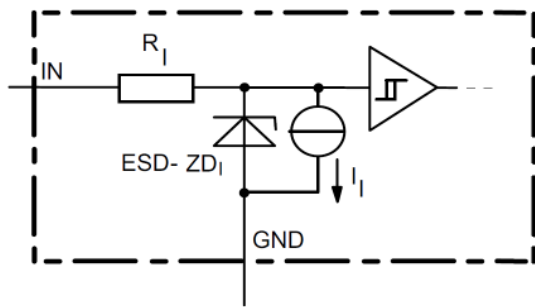

The use of ESD zener diodes as voltage clamp at DC conditions is not recommended

Overvoltage protection of logic part

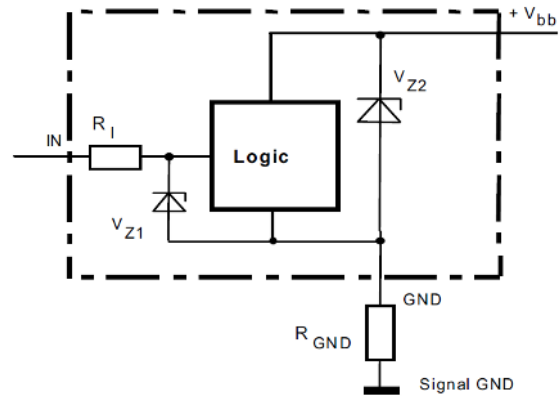

$V_{Z1} = 6.1 \text{ V typ.}$, $V_{Z2} = V_{bb(AZ)} = 47 \text{ V typ.}$, $R_I = 3.5 \text{ k}\Omega \text{ typ.}$, $R_{GND} = 150 \text{ }\Omega$

Functional description and electrical characteristics

Reverse battery protection

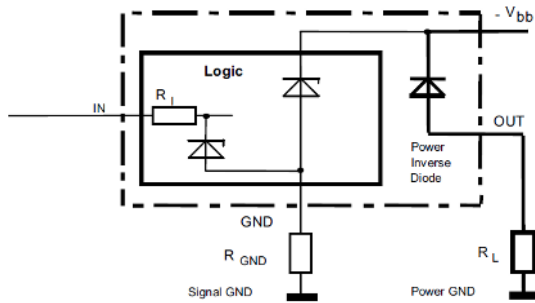

$R_{GND} = 150 \Omega$, $R_I = 3.5 \text{ k}\Omega$ typ., temperature protection is not active during inverse current

GND disconnect

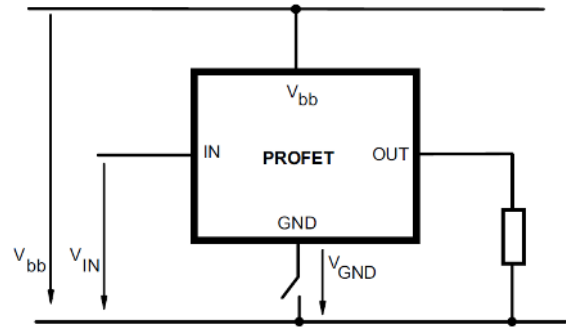

V_{bb} disconnect with charged inductive load

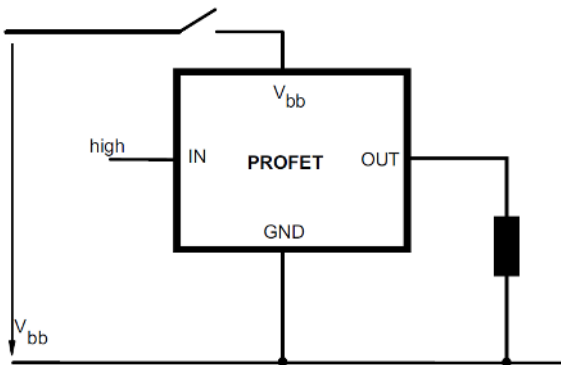

GND disconnect with GND pull up

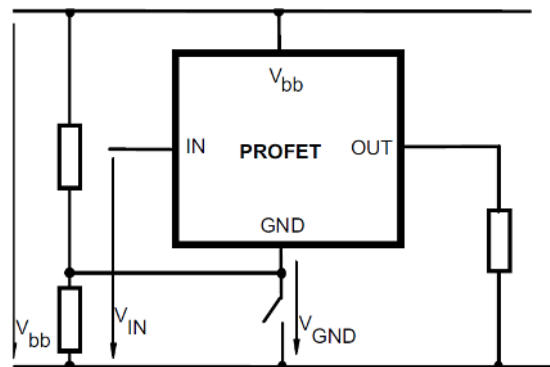

Inductive load switch-off energy dissipation

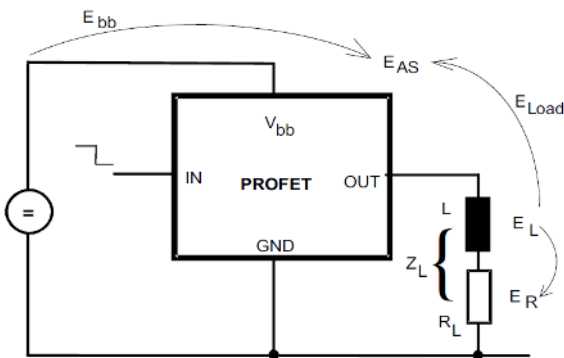

Energy stored in load inductance:

$$E_L = 1/2 \times L \times I_L^2$$

While demagnetizing load inductance, the energy dissipated in PROFET is:

$$E_{AS} = E_{bb} + E_L - E_R = V_{ON(CL)} \times I_L(t) dt$$

with an approximate solution for $R_L > 0 \Omega$:

$$E_{AS} = \frac{I_L \times L}{2 \times R_L} \times (V_{bb} + |V_{UT(CL)}|) \times \ln\left(1 + \frac{I_L \times R_L}{|V_{OUT(CL)}|}\right)$$

Functional description and electrical characteristics

4.2 Electrical characteristics

Table 4 Electrical characteristics

$T_j = -40^\circ\text{C}$ to $+150^\circ\text{C}$, $V_{bb} = 13.5\text{ V}$, unless otherwise specified

Parameter	Symbol	Values			Unit	Note or condition
		Min.	Typ.	Max.		
Load switching capabilities and characteristics						
On-state resistance $T_j = 25^\circ\text{C}$, $I_L = 2\text{ A}$, $V_{bb} = 9\text{ V}$ to 40 V $T_j = 150^\circ\text{C}$	R_{ON}	–	70	100	mΩ	–
		–	140	200		
Nominal load current	$I_{L(nom)}$	2	2.4	–	A	Device on PCB ⁵⁾ $T_C = 85^\circ\text{C}$, $T_j \leq 150^\circ\text{C}$
Turn-on time to 90% V_{OUT}	t_{on}	–	90	170	μs	$R_L = 47\ \Omega$
Turn-off time to 10% V_{OUT}	t_{off}	–	90	230	μs	$R_L = 47\ \Omega$
Slew rate on 10% to 30% V_{OUT}	dV/dt_{on}	–	0.8	1.7	V/μs	$R_L = 47\ \Omega$
Slew rate off 70% to 40% V_{OUT}	$-dV/dt_{off}$	–	0.8	1.7	V/μs	$R_L = 47\ \Omega$
Operating parameters						
Operating voltage	$V_{bb(on)}$	5	–	34	V	–
Undervoltage shutoff charge pump $T_j = -40^\circ\text{C}$ to $+85^\circ\text{C}$ $T_j = 150^\circ\text{C}$	$V_{bb(under)}$	–	–	4	V	–
		–	–	5.5		
Undervoltage restart of charge pump	$V_{bb(u\ cp)}$	–	4	5.5	V	–
Standby current $T_j = -40^\circ\text{C}$ to $+85^\circ\text{C}$, $V_{IN} = 0\text{ V}$ $T_j = 150^\circ\text{C}$ ⁶⁾ , $V_{IN} = 0\text{ V}$	$I_{bb(off)}$	–	–	10	μA	
		–	–	15		
Leakage output current	$I_{L(off)}$	–	–	5	μA	included in $I_{bb(off)}$ $V_{IN} = 0\text{ V}$
Operating current	I_{GND}	–	0.5	1.3	mA	$V_{IN} = 5\text{ V}$
Protection functions ⁷⁾						
Initial peak short circuit current limit (pin 5 to 3) $T_j = -40^\circ\text{C}$, $V_{bb} = 20\text{ V}$, $t_m = 150\ \mu\text{s}$ $T_j = 25^\circ\text{C}$ $T_j = 150^\circ\text{C}$	$I_{L(SCp)}$	–	–	18	A	–
		–	10	–		
		4	–	–		

⁵⁾ Device on 50 mm × 50 mm × 1.5 mm epoxy PCB FR4 with 6 cm² (one layer, 70 μm thick) copper area for drain connection. PCB is vertical without blown air. (see page 18)

⁶⁾ Higher current due temperature sensor

⁷⁾ Integrated protection functions are designed to prevent IC destruction under fault conditions described in the data sheet. Fault conditions are considered as "outside" normal operating range. Protection functions are not designed for continuous repetitive operation.

Functional description and electrical characteristics

Table 4 Electrical characteristics (continued)

$T_j = -40^\circ\text{C}$ to $+150^\circ\text{C}$, $V_{bb} = 13.5\text{ V}$, unless otherwise specified

Parameter	Symbol	Values			Unit	Note or condition
		Min.	Typ.	Max.		
Repetitive short circuit current limit	$I_{L(\text{SCR})}$	–	7	–	A	$T_j = T_{jt}$ (see Timing diagrams)
Output clamp (inductive load switch off)	$V_{\text{ON}(\text{CL})}$	41	47	–	V	$V_{\text{OUT}} = V_{bb} - V_{\text{ON}(\text{CL})}$, $I_{bb} = 4\text{ mA}$
Overvoltage protection	$V_{bb(\text{AZ})}$	41	–	–	V	⁸⁾ $I_{bb} = 4\text{ mA}$
Thermal overload trip temperature	T_{jt}	150	–	–	$^\circ\text{C}$	–
Thermal hysteresis	ΔT_{jt}	–	10	–	K	–

Reverse battery

Reverse battery	$-V_{bb}$	–	–	32	V	⁹⁾
Drain-source diode voltage	$-V_{\text{ON}}$	–	600	–	mV	$V_{\text{OUT}} > V_{bb}$, $T_j = 150^\circ\text{C}$

Input

Input turn-on threshold voltage	$V_{\text{IN}(\text{T}+)}$	–	–	2.2	V	(see page 15)
Input turn-off threshold voltage	$V_{\text{IN}(\text{T}-)}$	0.8	–	–	V	(see page 15)
Input threshold hysteresis	$\Delta V_{\text{IN}(\text{T})}$	–	0.3	–	V	–
Off state input current	$I_{\text{IN}(\text{off})}$	1	–	25	μA	$V_{\text{IN}} = 0.7\text{ V}$, (see page 15)
On state input current	$I_{\text{IN}(\text{on})}$	3	–	25	μA	$V_{\text{IN}} = 5\text{ V}$, (see page 15)
Input resistance	R_I	1.5	3.5	5	k Ω	(see page 8)

⁸ See also $V_{\text{ON}(\text{CL})}$ in circuit diagram on page [8](#)

⁹ Requires a 150 Ω resistor in GND connection. The reverse load current through the intrinsic drain-source diode has to be limited by the connected load. Power dissipation is higher compared to normal operating conditions due to the voltage drop across the drain-source diode. The temperature protection is not active during reverse current operation! Input current has to be limited (see max. ratings page [6](#)).

Functional description and electrical characteristics

4.3 Typical performance characteristics

**Typ. transient thermal impedance $Z_{thJA} = f(t_p)$
 @ 6 cm² heatsink area**

$D = t_p/T$

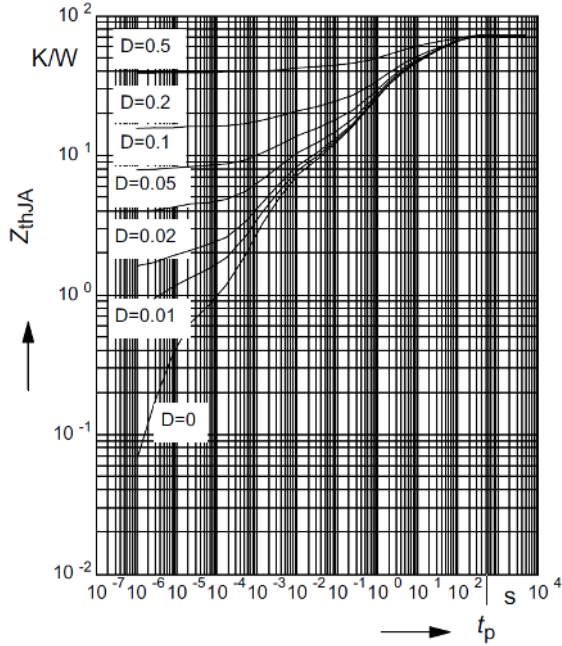

**Typ. transient thermal impedance $Z_{thJA} = f(t_p)$
 @ minimum footprint**

$D = t_p/T$

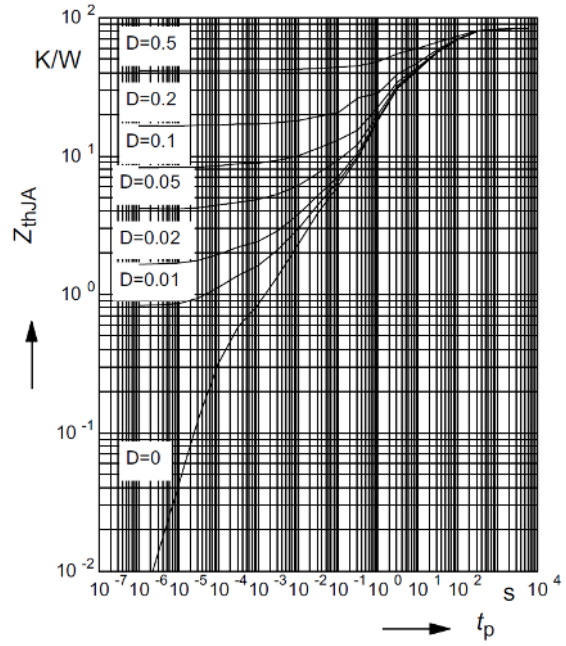

Typ. on-state resistance $R_{ON} = f(T_j)$

$V_{bb} = 13.5\text{ V}; V_{IN} = \text{high}$

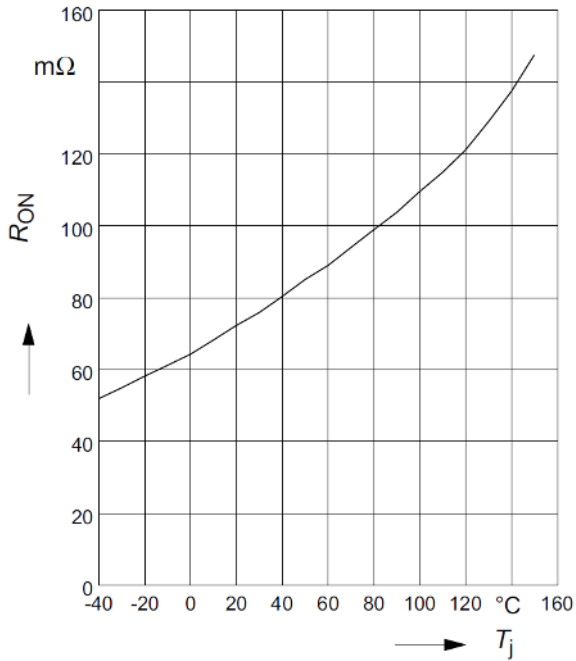

Typ. on-state resistance $R_{ON} = f(V_{bb})$

$I_L = 0.5\text{ A}; V_{IN} = \text{high}$

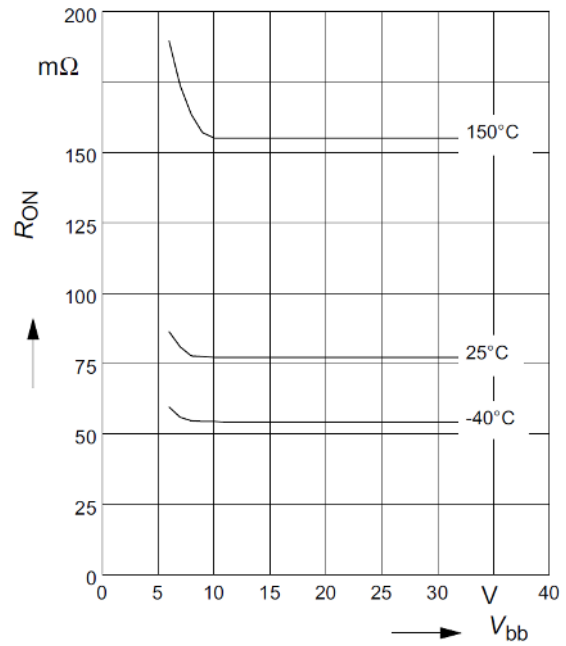

Functional description and electrical characteristics

Typ. turn on time $t_{on} = f(T_j)$

$R_L = 47 \Omega$

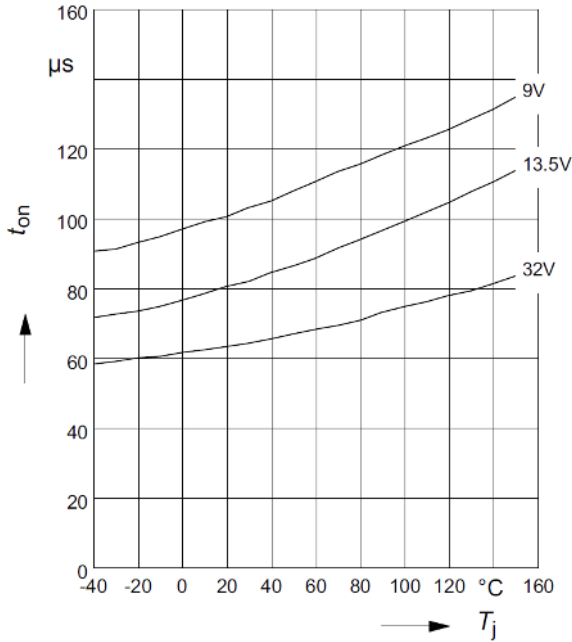

Typ. turn off time $t_{off} = f(T_j)$

$R_L = 47 \Omega$

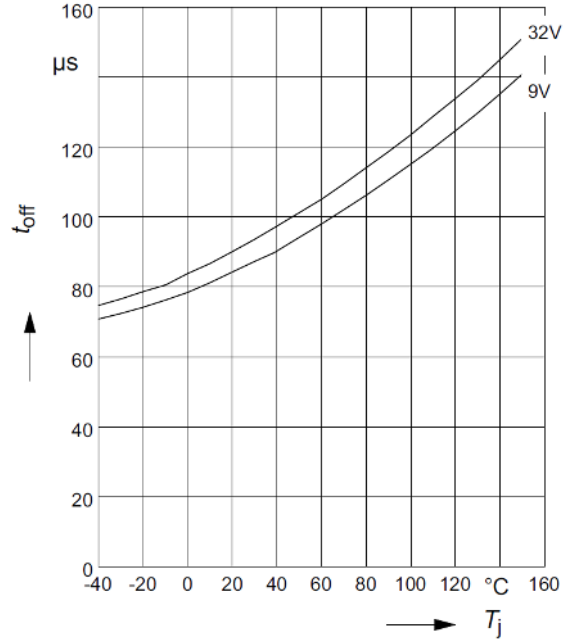

Typ. slew rate on $dV/dt_{on} = f(T_j)$

$R_L = 47 \Omega$

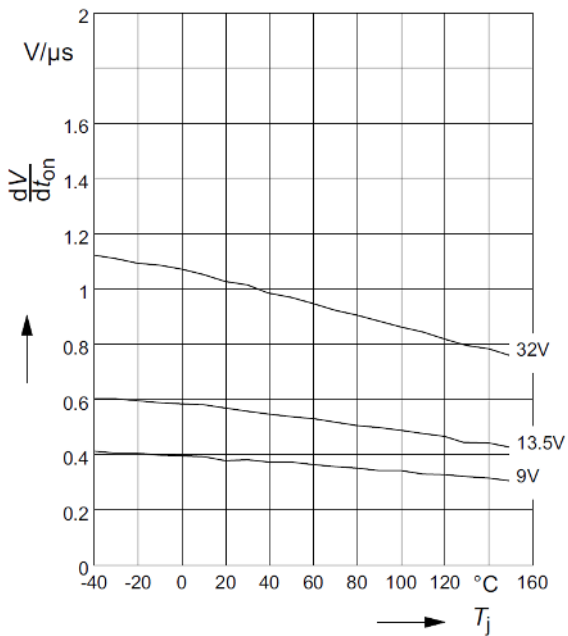

Typ. slew rate off $dV/dt_{off} = f(T_j)$

$R_L = 47 \Omega$

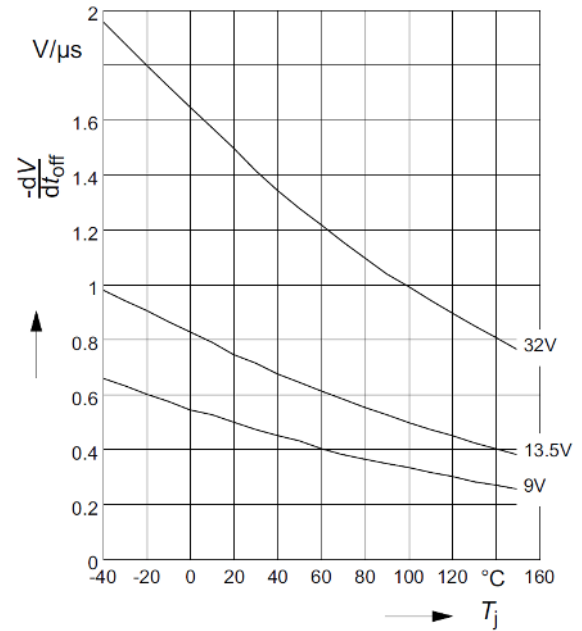

Functional description and electrical characteristics

Typ. standby current $I_{bb(off)} = f(T_j)$

$V_{bb} = 32\text{ V}; V_{IN} = \text{low}$

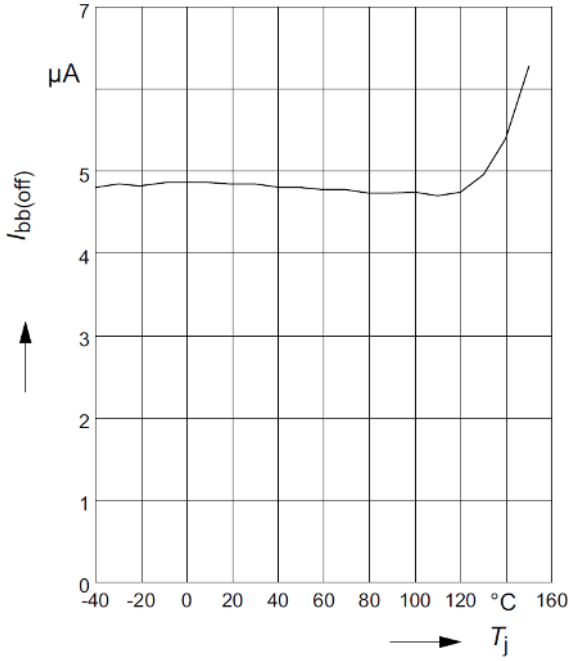

Typ. leakage current $I_{L(off)} = f(T_j)$

$V_{bb} = 32\text{ V}; V_{IN} = \text{low}$

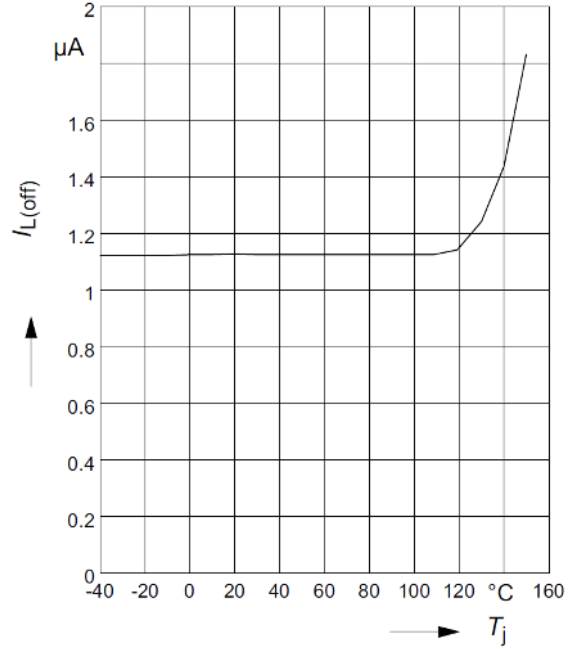

Typ. initial peak short circuit current limit $I_{L(SCp)} = f(T_j)$

$V_{bb} = 20\text{ V}$

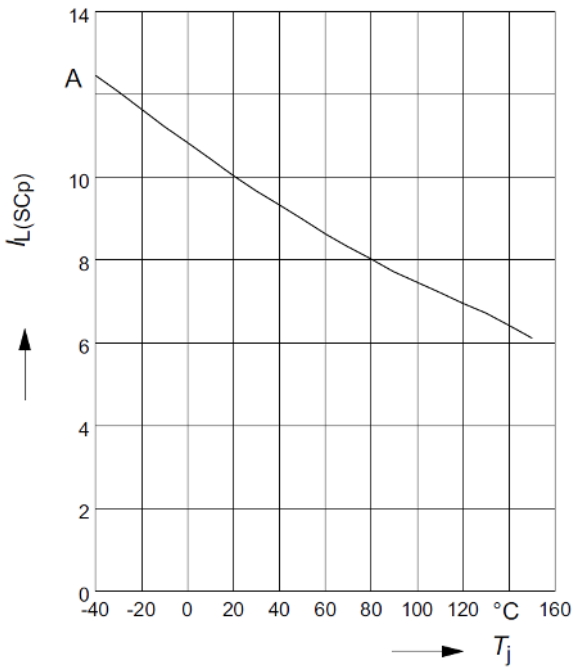

Typ. initial short circuit shutdown time $t_{off(SC)} = f(T_{j,start})$

$V_{bb} = 20\text{ V}$

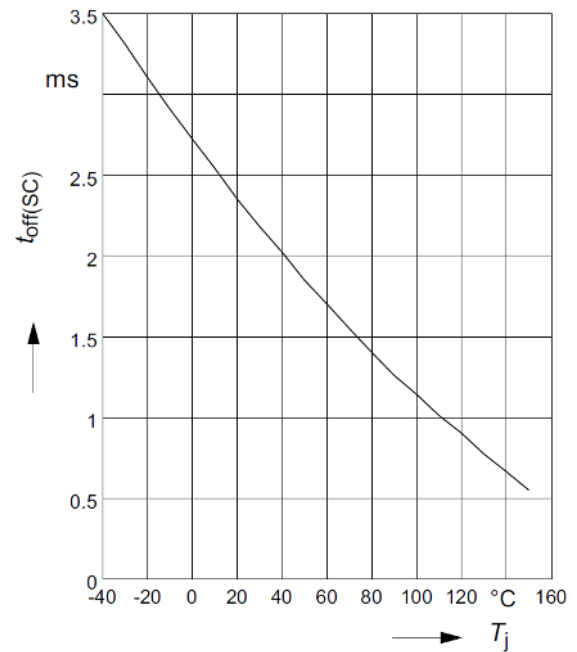

Functional description and electrical characteristics

Typ. input current $I_{IN(on/off)} = f(T_j)$

$V_{bb} = 13.5\text{ V}$; $V_{IN} = \text{low/high}$; $V_{INlow} \leq 0.7\text{ V}$; $V_{INhigh} = 5\text{ V}$

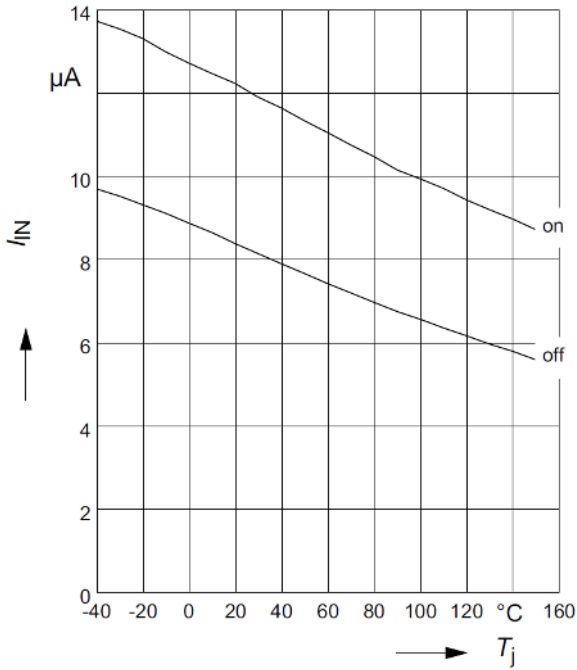

Typ. input current $I_{IN} = f(V_{IN})$

$V_{bb} = 13.5\text{ V}$

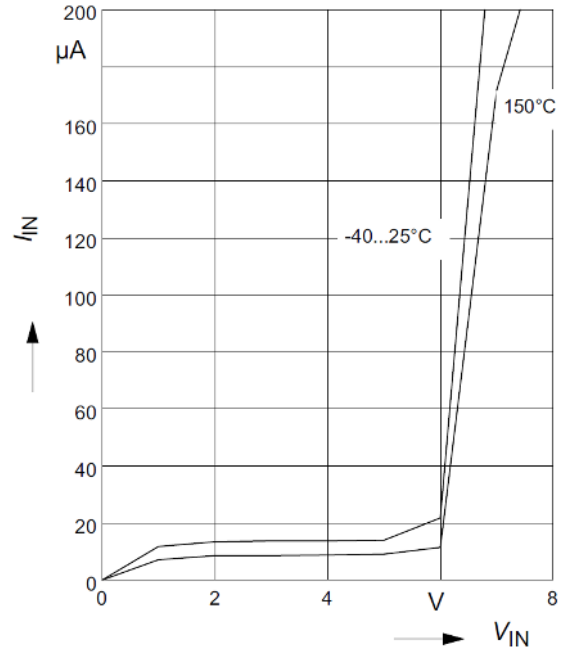

Typ. Input threshold voltage $V_{IN(th)} = f(T_j)$

$V_{bb} = 13.5\text{ V}$

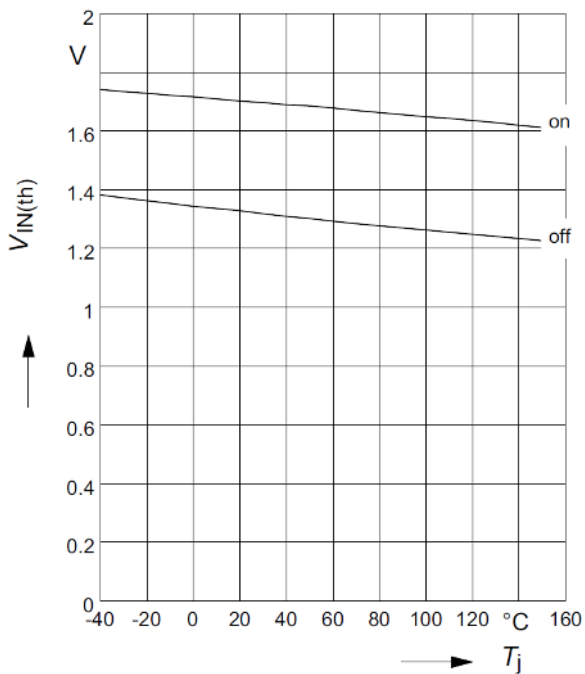

Typ. Input threshold voltage $V_{IN(th)} = f(V_{bb})$

$T_j = 25^{\circ}\text{C}$

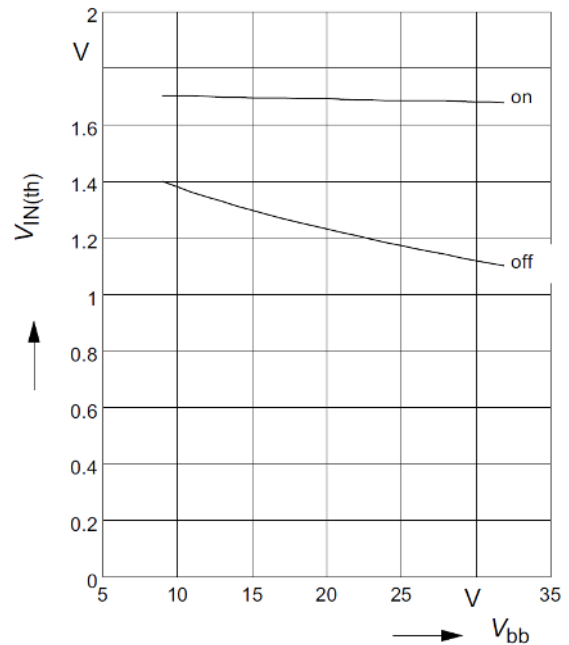

Functional description and electrical characteristics

Maximum allowable load inductance for a single switch off $L = f(I_L)$

$T_{jstart} = 150^{\circ}\text{C}$, $V_{bb} = 13.5\text{ V}$, $R_L = 0\ \Omega$

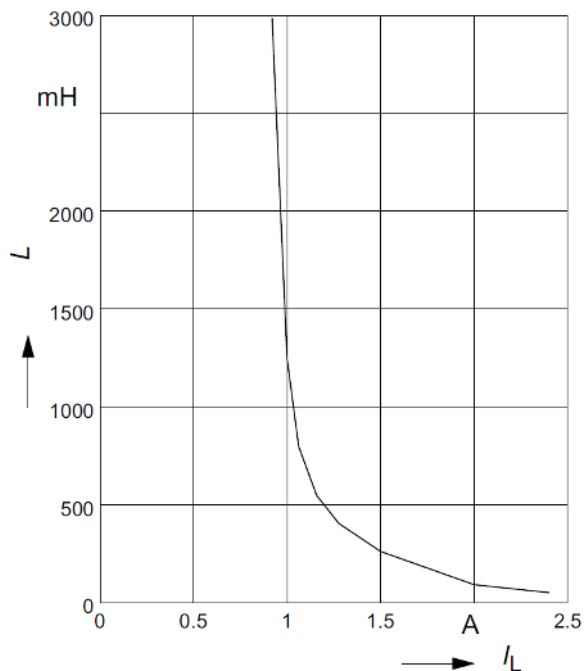

Maximum allowable inductive switch off energy, single pulse $E_{AS} = f(I_L)$

$T_{jstart} = 150^{\circ}\text{C}$, $V_{bb} = 13.5\text{ V}$

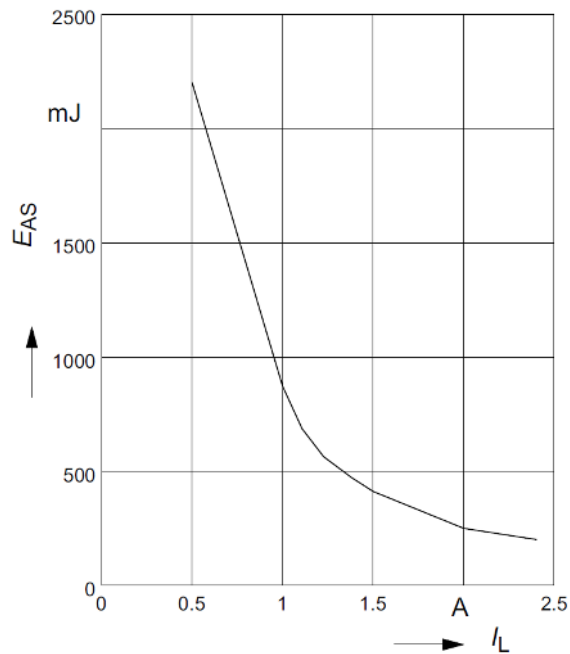

Functional description and electrical characteristics

4.4 Timing diagrams

Turn on into short circuit, shut down by overtemperature, restart by cooling

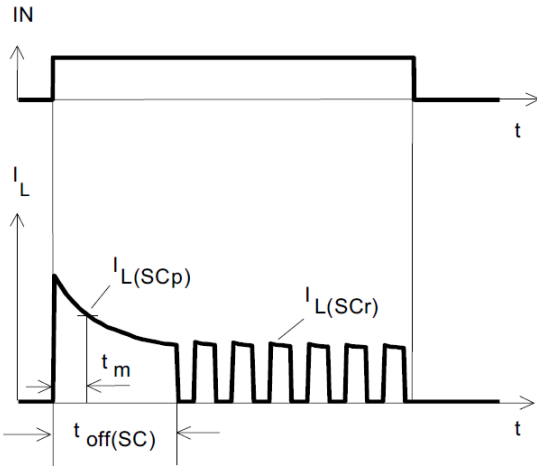

Undervoltage restart of charge pump

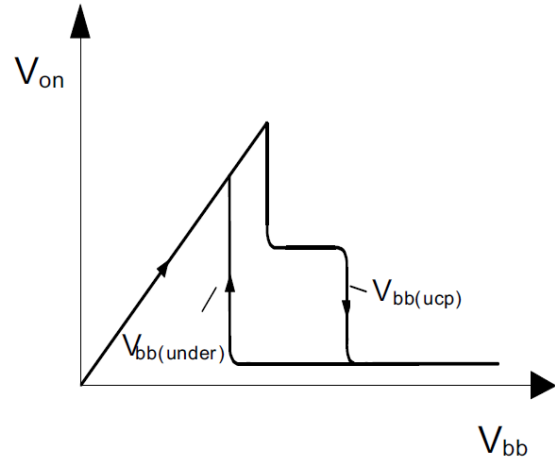

Heating up of the chip may require several milliseconds, depending on external conditions.

Overtemperature: Reset if $T_j < T_{jt}$

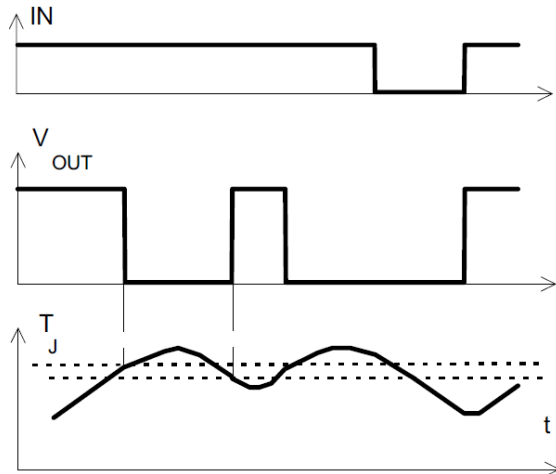

Package information

5 Package information

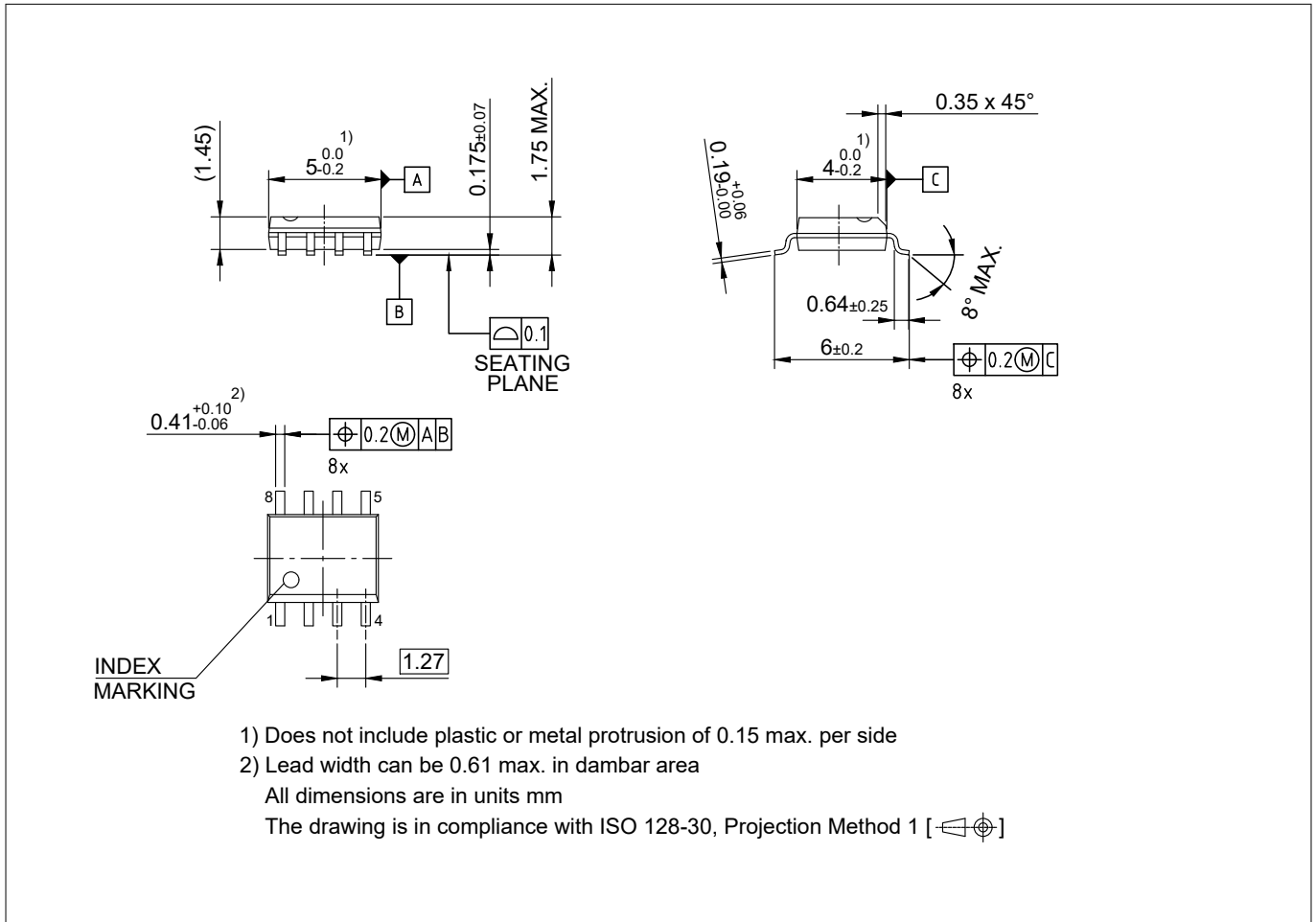

Figure 3 PG-DSO-8

Green Product (RoHS compliant)

To meet the world-wide customer requirements for environmentally friendly products and to be compliant with government regulations the device is available as a green product. Green products are RoHS-Compliant (Pb-free finish on leads and suitable for Pb-free soldering according to IPC/JEDEC J-STD-020).

Information on alternative packages

Please visit www.infineon.com/packages.

Revision history

6 Revision history

Document version	Date of release	Description of changes
1.5	2019-07-25	Datasheet updated: <ul style="list-style-type: none">• ESD ratings for HBM updated according to ANSI/ESDA/JEDEC JS-001• Editorial changes

Trademarks

All referenced product or service names and trademarks are the property of their respective owners.

Edition 2019-07-25

Published by

Infineon Technologies AG

81726 Munich, Germany

© 2019 Infineon Technologies AG

All Rights Reserved.

Do you have a question about any aspect of this document?

Email: erratum@infineon.com

Document reference

IFX-Z8F51361649

IMPORTANT NOTICE

The information given in this document shall in no event be regarded as a guarantee of conditions or characteristics ("Beschaffheitsgarantie").

With respect to any examples, hints or any typical values stated herein and/or any information regarding the application of the product, Infineon Technologies hereby disclaims any and all warranties and liabilities of any kind, including without limitation warranties of non-infringement of intellectual property rights of any third party.

In addition, any information given in this document is subject to customer's compliance with its obligations stated in this document and any applicable legal requirements, norms and standards concerning customer's products and any use of the product of Infineon Technologies in customer's applications.

The data contained in this document is exclusively intended for technically trained staff. It is the responsibility of customer's technical departments to evaluate the suitability of the product for the intended application and the completeness of the product information given in this document with respect to such application.

Please note that this product is not qualified according to the AEC Q100 or AEC Q101 documents of the Automotive Electronics Council.

WARNINGS

Due to technical requirements products may contain dangerous substances. For information on the types in question please contact your nearest Infineon Technologies office.

Except as otherwise explicitly approved by Infineon Technologies in a written document signed by authorized representatives of Infineon Technologies, Infineon Technologies' products may not be used in any applications where a failure of the product or any consequences of the use thereof can reasonably be expected to result in personal injury