

**Model 73059**

**UHF Plug, Clamp Type, RG8, 9, 11, 63, 87A, 213, 214, 225**

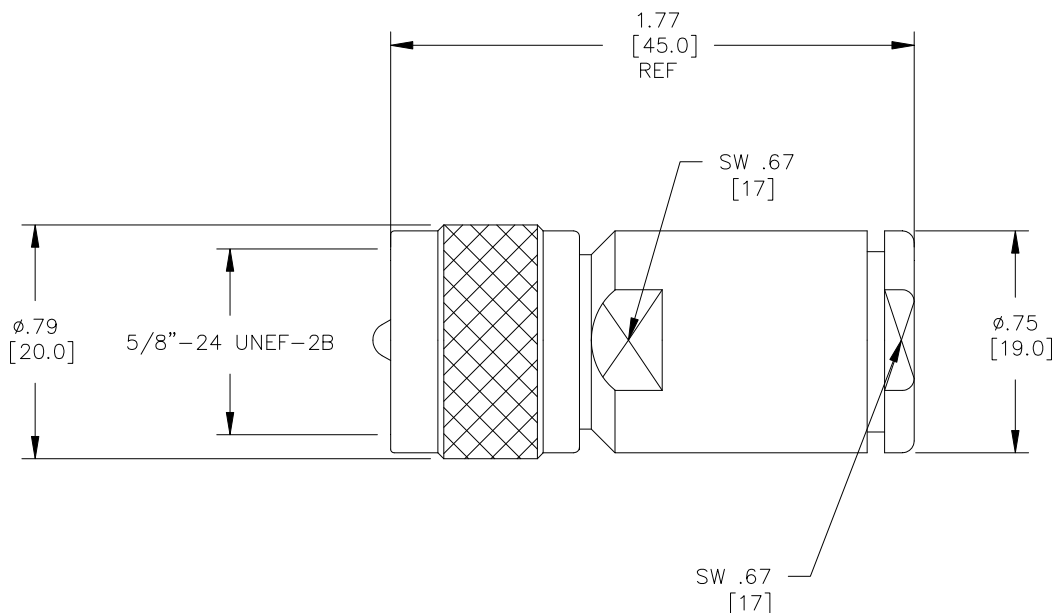

*Model 73059  
UHF Plug, Clamp Type,  
RG8, 9, 11, 63, 87A, 213, 214, 225*

**Features**

- DC – 300MHz bandwidth.
- Connectors are precision machined.
- Meets interface requirements MIL-C-39012.
- Connector accepts cable types RG/U: 8, 9, 11, 63, 87A, 213, 214, 225

**Materials**

Center Conductor, Male:  
Phosphor Bronze, Gold Plated  
Connector Body: Brass, Nickel Plated  
Insulators: PTFE

**Specifications**

Frequency Range:	DC – 300MHz
Contact Resistance:	
Center Conductor:	≤1.0 mΩ
Outer Conductor:	≤0.2 mΩ
Insulation Resistance:	≥ 300 MΩ
Dielectric Withstand Voltage:	750V
	<i>For CE compliance, do not hold in hand when voltages exceed 33 Vrms / 70 Vdc.</i>
Number of Insertions:	500 cycles minimum

**Ordering Information**

Model: **73059**

**USA:** Sales: 800-490-2361  
Technical Support: [technicalsupport@pomonatest.com](mailto:technicalsupport@pomonatest.com)  
Fax: 425-446-5844

**Europe:** 31-(0) 40 2675 150 **International:** 425-446-5500

**Where to Buy:** [www.pomonaelectronics.com](http://www.pomonaelectronics.com)

All dimensions are in inches. Tolerances (except noted): .xx = ±.02" (.51 mm), .xxx = ± .005" (.127 mm). All specifications are to the latest revisions. Specifications are subject to change without notice. Registered trademarks are the property of their respective companies.

**Model 73059**  
**UHF Plug, Clamp Type, RG8, 9, 11, 63, 87A, 213, 214, 225**

**Cable Types**

Connector Model #	Cable Groups
73059	RG8, 9, 11, 63, 87A, 213, 214, 225

**Cable Assembly Instructions**

1. CUT CABLE END EVENLY AND PERPENDICULAR

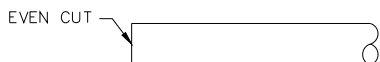

2. SLIDE NUT WASHERS AND FERRULE OVER CABLE AS SHOWN.

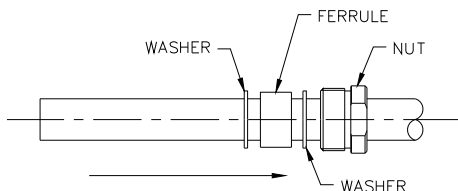

3. STRIP CABLE JACKET, BRAID AND DIELECTRIC TO SPECIFIC LENGTHS.

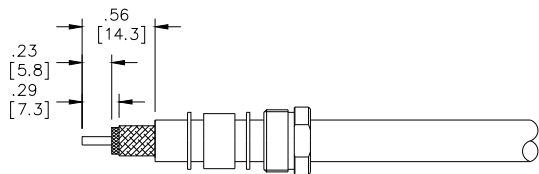

4. FLARE BRAID END SLIGHTLY.

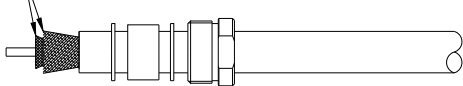

5. SLIDE BRAID CLAMP UNDER BRAID. SLIDE WASHER OVER CENTER CONDUCTOR. CRIMP CENTER CONTACT ONTO CENTER CONDUCTOR.

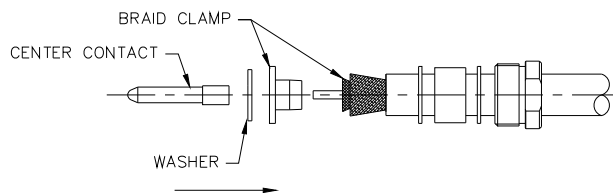

6. SLIDE FORWARD WASHERS FERRULE AND NUT OVER BRAID.

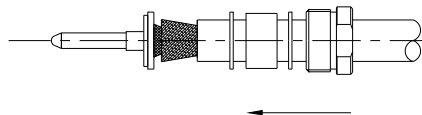

7. SLIDE CONNECTOR BODY OVER ASSEMBLY AND SCREW NUT.

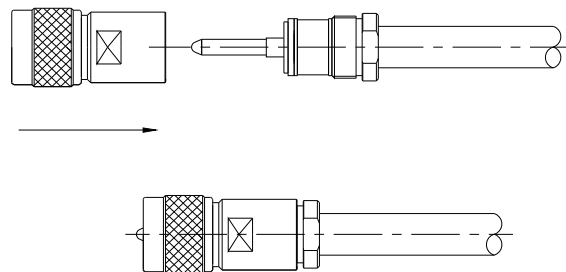

**USA:** Sales: 800-490-2361  
 Technical Support: [technicalsupport@pomonatest.com](mailto:technicalsupport@pomonatest.com)  
 Fax: 425-446-5844  
**Europe:** 31-(0) 40 2675 150 **International:** 425-446-5500  
**Where to Buy:** [www.pomonaelectronics.com](http://www.pomonaelectronics.com)

All dimensions are in inches. Tolerances (except noted): .xx = ±.02" (.51 mm), .xxx = ±.005" (.127 mm). All specifications are to the latest revisions. Specifications are subject to change without notice. Registered trademarks are the property of their respective companies.