

# Low Skew CMOS PLL Clock Drivers With Processor Reset

**MC88916**

The MC88916 Clock Driver utilizes phase-locked loop technology to lock its low skew outputs' frequency and phase onto an input reference clock. It is designed to provide clock distribution for CISC microprocessor or single processor RISC systems. The RST\_IN/RST\_OUT(LOCK) pins provide a processor reset function designed specifically for the MC68/EC/LC030/040 microprocessor family. The 88916 comes in two speed grades: 70 and 80MHz. These frequencies correspond to the 2X\_Q maximum output frequency. The two grades should be ordered as the MC88916DW70 and MC88916DW80, respectively.

- Provides Performance Required to Drive 68030 Microprocessor Family as well as the 33 and 40MHz 68040 Microprocessors
- Three Outputs (Q0-Q2) With Output-Output Skew <500ps and Six Outputs Total (Q0-Q2, Q3, 2X\_Q,) With <1ns Skew Each Being Phase and Frequency Locked to the SYNC Input
- The Phase Variation From Part-to-Part Between SYNC and the 'Q' Outputs Is Less Than 600ps (Derived From the T<sub>PD</sub> Specification, Which Defines the Part-to-Part Skew)
- SYNC Input Frequency Range From 5MHz to 2X\_Q F<sub>Max</sub>/4
- Additional Outputs Available at 2X and +2 the System 'Q' Frequency. Also a Q (180° Phase Shift) Output Available.
- All Outputs Have ±36mA Drive (Equal High and Low) CMOS Levels. Can Drive Either CMOS or TTL Inputs. All Inputs Are TTL-Level Compatible
- Test Mode Pin (PLL\_EN) Provided for Low Frequency Testing

The PLL allows the high current, low skew outputs to lock onto a single clock input and distribute it with essentially zero delay to multiple locations on a board. The PLL also allows the MC88916 to multiply a low frequency input clock and distribute it locally at a higher (2X) system frequency.

Three 'Q' outputs (Q0-Q2) are provided with less than 500ps skew between their rising edges. The Q3 output is inverted (180° phase shift) from the 'Q' outputs. A 2X\_Q output runs at twice the 'Q' output frequency. The 2X\_Q output does not meet the stringent duty cycle requirement of the 20 and 25Mhz 68040 microprocessor PCLK input. The 88920 has been designed specifically to provide the 68040 PCLK and BCLK inputs for the low frequency 68040 microprocessor. 68040 designers should refer to the 88920 data sheet for more details. For the 33 and 40MHz 68040, the 2X\_Q output will meet the duty cycle requirements of the PCLK input. The Q/2 output runs at 1/2 the 'Q' frequency. This output is fed back internally, providing a fixed 2X multiplication from the 'Q' outputs to the SYNC input. Since the feedback is done internally (no external feedback pin is provided) the input/output frequency relationships are fixed.

In normal phase-locked operation the PLL\_EN pin is held high. Pulling the PLL\_EN pin low disables the VCO and puts the 88916 in a static 'test mode'. In this mode there is no frequency limitation on the input clock, which is necessary for a low frequency board test environment.

The RST\_OUT(LOCK) pin doubles as a phase-lock indicator. When the RST\_IN pin is held high, the open drain RST\_OUT pin will be pulled actively low until phase-lock is achieved. When phase-lock occurs, the RST\_OUT(LOCK) is released and a pull-up resistor will pull the signal high. To give a processor reset signal, the RST\_IN pin is toggled low, and the RST\_OUT(LOCK) pin will stay low for 1024 cycles of the 'Q' output frequency after the RST\_IN pin is brought back high.

### Description of the RST\_IN/RST\_OUT(LOCK) Functionality

The RST\_IN and RST\_OUT(LOCK) pins provide a 68030/040 processor reset function, with the RST\_OUT pin also acting as a lock indicator. If the RST\_IN pin is held high during system power-up, the RST\_OUT pin will be in the low state until steady state phase/frequency lock to the input reference is achieved. 1024 'Q' output cycles after phase-lock is achieved the RST\_OUT(LOCK) pin will go into a high impedance state, allowing it to be pulled high by an external pull-up resistor (see the AC/DC specs for the characteristics of the RST\_OUT(LOCK) pin). If the RST\_IN pin is held low during power-up, the RST\_OUT(LOCK) pin will remain low.

**LOW SKEW CMOS PLL  
CLOCK DRIVER WITH  
PROCESSOR RESET**

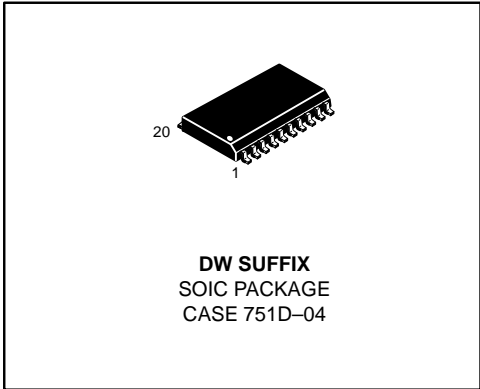

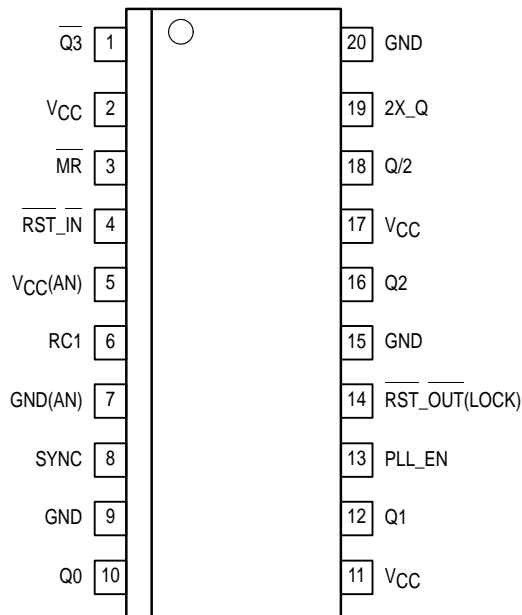

Pinout: 20-Lead Wide SOIC Package (Top View)

#### Description of the $\overline{\text{RST\_IN}}/\overline{\text{RST\_OUT(LOCK)}}$ Functionality (continued)

After the system start-up is complete and the 88916 is phase-locked to the SYNC input signal ( $\overline{\text{RST\_OUT}}$  high), the processor reset functionality can be utilized. When the  $\overline{\text{RST\_IN}}$  pin is toggled low (min. pulse width=10nS),  $\overline{\text{RST\_OUT(LOCK)}}$  will go to the low state and remain there for 1024 cycles of the 'Q' output frequency (512 SYNC cycles). During the time in which the  $\overline{\text{RST\_OUT(LOCK)}}$  is actively pulled low, all the 88916 clock outputs will continue operating correctly and in a locked condition to the SYNC input (clock signals to the 68030/040 family of processors must continue while the processor is in reset). A propagation delay after the 1024th cycle  $\overline{\text{RST\_OUT(LOCK)}}$  goes back to the high impedance state to be pulled high by the resistor.

#### Power Supply Ramp Rate Restriction for Correct 68030 Processor Reset Operation During System Start-up

Because the  $\overline{\text{RST\_OUT(LOCK)}}$  pin is an indicator of

phase-lock to the reference source, some constraints must be placed on the power supply ramp rate to make sure the  $\overline{\text{RST\_OUT(LOCK)}}$  signal holds the processor in reset during system start-up (power-up). With the recommended loop filter values (see Figure 7) the lock time is approximately 10ms. The phase-lock loop will begin attempting to lock to a reference source (if it is present) when VCC reaches 2V. If the VCC ramp rate is significantly slower than 10ms, then the PLL could lock to the reference source, causing  $\overline{\text{RST\_OUT(LOCK)}}$  to go high before the 88916 and 68030 processor is fully powered up, violating the processor reset specification. Therefore, if it is necessary for the  $\overline{\text{RST\_IN}}$  pin to be held high during power-up, the VCC ramp rate must be less than 10mS for proper 68030/040 reset operation.

This ramp rate restriction can be ignored if the  $\overline{\text{RST\_IN}}$  pin can be held low during system start-up (which holds  $\overline{\text{RST\_OUT}}$  low). The  $\overline{\text{RST\_OUT(LOCK)}}$  pin will then be pulled back high 1024 cycles after the  $\overline{\text{RST\_IN}}$  pin goes high.

#### CAPACITANCE AND POWER SPECIFICATIONS

Symbol	Parameter	Value Typ	Unit	Test Conditions
C <sub>IN</sub>	Input Capacitance	4.5	pF	V <sub>CC</sub> = 5.0V
C <sub>PD</sub>	Power Dissipation Capacitance	40	pF	V <sub>CC</sub> = 5.0V
PD <sub>1</sub>	Power Dissipation at 33MHz With 50Ω Thevenin Termination	15mW/Output 90mW/Device	mW	V <sub>CC</sub> = 5.0V T = 25°C
PD <sub>2</sub>	Power Dissipation at 33MHz With 50Ω Parallel Termination to GND	37.5mW/Output 225mW/Device	mW	V <sub>CC</sub> = 5.0V T = 25°C

## MAXIMUM RATINGS\*

Symbol	Parameter	Limits	Unit
V <sub>CC</sub> , AV <sub>CC</sub>	DC Supply Voltage Referenced to GND	-0.5 to 7.0	V
V <sub>in</sub>	DC Input Voltage (Referenced to GND)	-0.5 to V <sub>CC</sub> +0.5	V
V <sub>out</sub>	DC Output Voltage (Referenced to GND)	-0.5 to V <sub>CC</sub> +0.5	V
I <sub>in</sub>	DC Input Current, Per Pin	±20	mA
I <sub>out</sub>	DC Output Sink/Source Current, Per Pin	±50	mA
I <sub>CC</sub>	DC V <sub>CC</sub> or GND Current Per Output Pin	±50	mA
T <sub>stg</sub>	Storage Temperature	-65 to +150	°C

\* Maximum Ratings are those values beyond which damage to the device may occur. Functional operation should be restricted to the Recommended Operating Conditions.

## RECOMMENDED OPERATING CONDITIONS

Symbol	Parameter	Limits	Unit
V <sub>CC</sub>	Supply Voltage	5.0 ±10%	V
V <sub>in</sub>	DC Input Voltage	0 to V <sub>CC</sub>	V
V <sub>out</sub>	DC Output Voltage	0 to V <sub>CC</sub>	V
T <sub>A</sub>	Ambient Operating Temperature	-40 to 85	°C
ESD	Static Discharge Voltage	> 1500	V

DC CHARACTERISTICS (T<sub>A</sub> = -40°C to +85°C; V<sub>CC</sub> = 5.0V ± 5%)

Symbol	Parameter	V <sub>CC</sub>	Guaranteed Limits	Unit	Condition
V <sub>IH</sub>	Minimum High Level Input Voltage	4.75 5.25	2.0 2.0	V	V <sub>OUT</sub> = 0.1V or V <sub>CC</sub> - 0.1V
V <sub>IL</sub>	Minimum Low Level Input Voltage	4.75 5.25	0.8 0.8	V	V <sub>OUT</sub> = 0.1V or V <sub>CC</sub> - 0.1V
V <sub>OH</sub>	Minimum High Level Output Voltage	4.75 5.25	4.01 4.51	V	V <sub>IN</sub> = V <sub>IH</sub> or V <sub>IL</sub> I <sub>OH</sub> = -36mA -36mA
V <sub>OL</sub>	Minimum Low Level Output Voltage	4.75 5.25	0.44 0.44	V	V <sub>IN</sub> = V <sub>IH</sub> or V <sub>IL</sub> I <sub>OH</sub> = +36mA <sup>1</sup> +36mA
I <sub>IN</sub>	Maximum Input Leakage Current	5.25	±1.0	μA	V <sub>I</sub> = V <sub>CC</sub> , GND
I <sub>CC(T)</sub>	Maximum I <sub>CC</sub> /Input	5.25	2.0 <sup>2</sup>	mA	V <sub>I</sub> = V <sub>CC</sub> - 2.1V
I <sub>OLD</sub>	Minimum Dynamic <sup>3</sup> Output Current	5.25	88	mA	V <sub>OLD</sub> = 1.0V Max
I <sub>OHD</sub>		5.25	-88	mA	V <sub>OHD</sub> = 3.85 Min
I <sub>CC</sub>	Maximum Quiescent Supply Current	5.25	750	μA	V <sub>I</sub> = V <sub>CC</sub> , GND

1. I<sub>OL</sub> is +12mA for the RST\_OUT output.

2. The PLL\_EN input pin is not guaranteed to meet this specification.

3. Maximum test duration 2.0ms, one output loaded at a time.

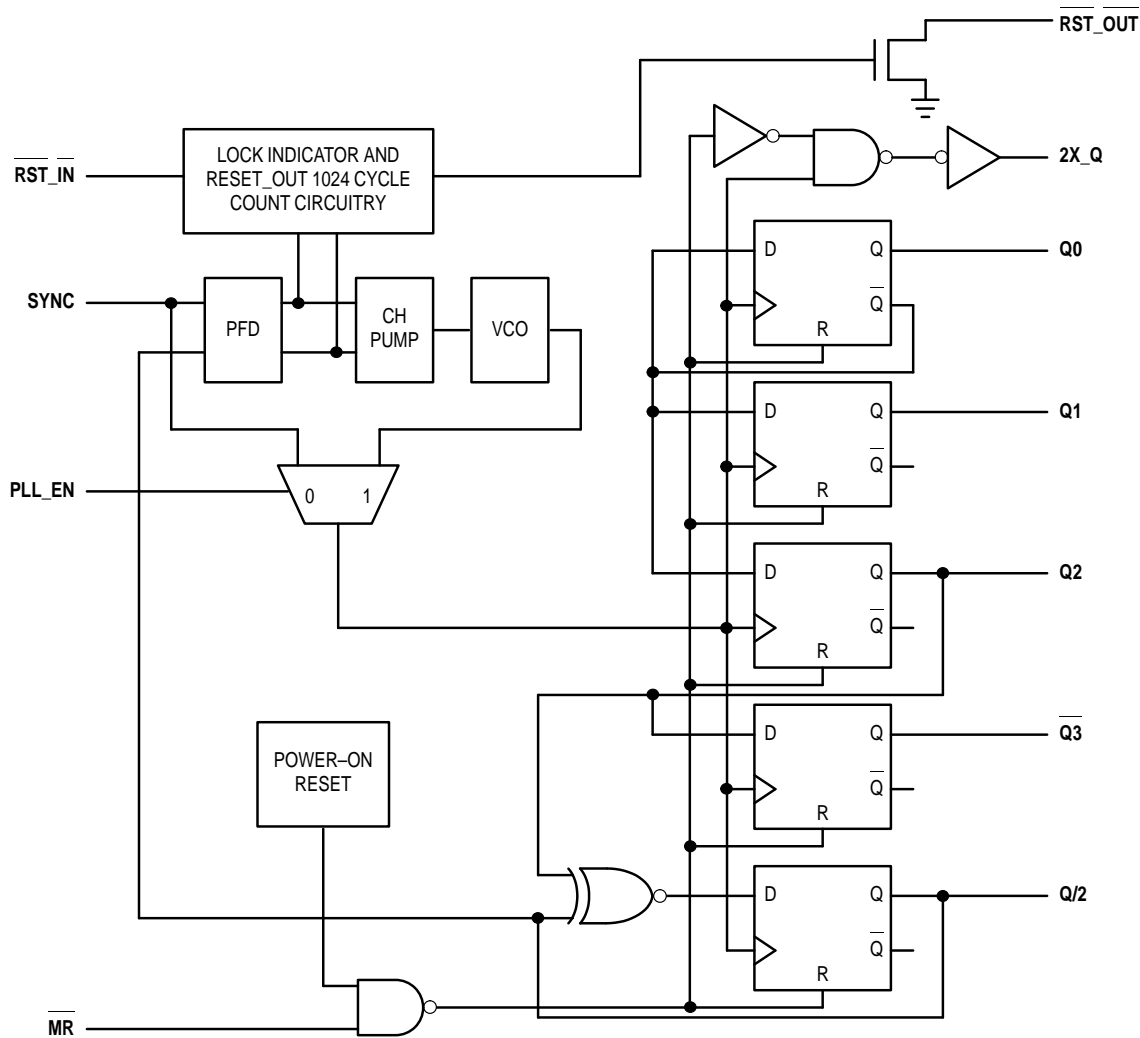

Figure 1. MC88916 Logic Block Diagram

**SYNC INPUT TIMING REQUIREMENTS**

Symbol	Parameter	Minimum	Maximum	Unit
$t_{RISE/FALL}$ SYNC Input	Rise/Fall Time, SYNC Input From 0.8V to 2.0V	—	5.0	ns
$t_{CYCLE}$ SYNC Input	Input Clock Period SYNC Input	'DW70 57	'DW80 50 200	ns
Duty Cycle	Duty Cycle, SYNC Input	50% ± 25%		

**FREQUENCY SPECIFICATIONS** ( $T_A = -40^{\circ}\text{C}$  to  $+85^{\circ}\text{C}$ ;  $V_{CC} = 5.0\text{V} \pm 5\%$ )

Symbol	Parameter	Guaranteed Minimum		Unit
		MC88916DW70	MC88916DW80	
$F_{max}$ (2X_Q)	Maximum Operating Frequency, 2X_Q Output	70	80	MHz
$F_{max}$ ('Q')	Maximum Operating Frequency, Q0–Q2, Q3 Outputs	35	40	MHz

1. Maximum Operating Frequency is guaranteed with the 88916 in a phase-locked condition, and all outputs loaded at 50Ω terminated to  $V_{CC}/2$ .

AC CHARACTERISTICS ( $T_A = -40^{\circ}\text{C}$  to  $+85^{\circ}\text{C}$ ;  $V_{CC} = 5.0\text{V} \pm 5\%$ )

Symbol	Parameter	Minimum	Maximum	Unit	Condition
$t_{RISE/FALL}^1$ All Outputs	Rise/Fall Time, All Outputs into a 50 $\Omega$ Load	0.3	1.6	ns	$t_{RISE} - 0.8\text{V}$ to 2.0V $t_{FALL} - 2.0\text{V}$ to 0.8V
$t_{RISE/FALL}^1$ 2X_Q Output	Rise/Fall Time into a 20pF Load, With Termination Specified in AppNote 3	0.5	1.6	ns	$t_{RISE} - 0.8\text{V}$ to 2.0V $t_{FALL} - 2.0\text{V}$ to 0.8V
$t_{pulse\ width(a)}^1$ (Q0, Q1, Q2, Q3)	Output Pulse Width Q0, Q1, Q2, Q3 at $V_{CC}/2$	$0.5t_{cycle} - 0.5$	$0.5t_{cycle} + 0.5$	ns	50 $\Omega$ Load Terminated to $V_{CC}/2$ (See App Note 3)
$t_{pulse\ width(b)}^1$ (2X_Q Output)	Output Pulse Width 2X_Q at $V_{CC}/2$	40–49MHz $0.5t_{cycle} - 1.5^5$ 50–65MHz $0.5t_{cycle} - 1.0^5$ 66–80MHz $0.5t_{cycle} - 0.5$	$0.5t_{cycle} + 1.5^5$ $0.5t_{cycle} + 1.0^5$ $0.5t_{cycle} + 0.5$	ns	50 $\Omega$ Load Terminated to $V_{CC}/2$ (See App Note 3)
$t_{PD}^{1,4}$ SYNC – Q/2	SYNC Input to Q/2 Output Delay (Measured at SYNC and Q/2 Pins)	–0.75	–0.15	ns	With 1M $\Omega$ From RC1 to An $V_{CC}$ (See Application Note 2)
		+1.25 <sup>7</sup>	+3.25 <sup>7</sup>	ns	With 1M $\Omega$ From RC1 to An GND (See Application Note 2)
$t_{SKEW}^{1,2}$ (Rising)	Output-to-Output Skew Between Outputs Q0–Q2, Q/2 (Rising Edge Only)	—	500	ps	Into a 50 $\Omega$ Load Terminated to $V_{CC}/2$ (See Timing Diagram in Figure 6)
$t_{SKEW}^{1,2}$ (Falling)	Output-to-Output Skew Between Outputs Q0–Q2 (Falling Edge Only)	—	1.0	ns	Into a 50 $\Omega$ Load Terminated to $V_{CC}/2$ (See Timing Diagram in Figure 6)
$t_{SKEW}^{1,2}$	Output-to-Output Skew 2X_Q, Q/2, Q0–Q2 Rising Q3 Falling	—	1.0	ns	Into a 50 $\Omega$ Load Terminated to $V_{CC}/2$ (See Timing Diagram in Figure 6)
$t_{LOCK}^3$	Phase-Lock Acquisition Time, All Outputs to SYNC Input	1	10	ms	
$t_{PHL\ MR - Q}$	Propagation Delay, MR to Any Output (High–Low)	1.5	13.5	ns	Into a 50 $\Omega$ Load Terminated to $V_{CC}/2$ (See Timing Diagram in Figure 6)
$t_{REC, MR\ to\ SYNC}^6$	Reset Recovery Time rising MR edge to falling SYNC edge	9	—	ns	
$t_{W, MR\ LOW}^6$	Minimum Pulse Width, MR input Low	5	—	ns	
$t_{W, RST\_IN\ LOW}$	Minimum Pulse Width, RST_IN Low	10	—	ns	When in Phase-Lock
$t_{PZL}$	Output Enable Time _____ RST_IN Low to RST_OUT Low	1.5	16.5	ns	See Application Note 5
$t_{PLZ}$	Output Enable Time _____ RST_IN High to RST_OUT High Z	1016 'Q' Cycles (508 Q/2 Cycles)	1024 'Q' Cycles (512 Q/2 Cycles)	ns	See Application Note 5

1. These specifications are not tested, they are guaranteed by statistical characterization. See Application Note 1 for a discussion of this methodology.
2. Under equally loaded conditions and at a fixed temperature and voltage.
3. With  $V_{CC}$  fully powered-on:  $t_{CLOCK}$  Max is with  $C1 = 0.1\mu\text{F}$ ;  $t_{LOCK}$  Min is with  $C1 = 0.01\mu\text{F}$ .
4. See Application Note 4 for the distribution in time of each output referenced to SYNC.
5. Limits do not meet requirements of the 68040 microprocessor. Refer to the 88920 for a low frequency 68040 clock driver.
6. Specification is valid only when the PLL\_EN pin is low.
7. This is a typical specification only, worst case guarantees are not provided.

Application Notes

- Several specifications can only be measured when the MC88916 is in phase-locked operation. It is not possible to have the part in phase-lock on ATE (automated test equipment). Statistical characterization techniques were used to guarantee those specifications which cannot be measured on the ATE. MC88916 units were fabricated with key transistor properties intentionally varied to create a 14 cell designed experimental matrix. IC performance was characterized over a range of transistor properties (represented by the 14 cells) in excess of the expected process variation of the wafer fabrication area. IC performance to each specification and fab variation were used to set performance limits of ATE testable specifications within those which are to be guaranteed by statistical characterization. In this way, all units passing the ATE test will meet or exceed the non-tested specifications limits.
- A 1MΩ resistor tied to either Analog V<sub>CC</sub> or Analog GND, as shown in Figure 2, is required to ensure no jitter is present on the MC88916 outputs. This technique causes a phase offset between the SYNC input and the Q0 output, measured at the pins. The t<sub>PD</sub> spec describes how this offset varies with process, temperature, and voltage. The specs were arrived at by measuring the phase relationship for the 14 lots described in note 1 while the part was in phase-locked operation. The actual measurements were made with a 10MHz SYNC input (1.0ns edge rate from 0.8V to 2.0V). The phase measurements were made at 1.5V. See Figure 2 for a graphical description.

- The pulse width spec for the Q and 2Q\_X outputs is referenced to a V<sub>CC</sub>/2 threshold. To translate this down to a 1.5V reference with the same pulse width tolerance, the termination scheme pictured in Figure 3 must be used. This termination scheme is required to drive the PCLK input of the 68040 microprocessor with the 88916 outputs.
- The t<sub>PD</sub> spec (SYNC to Q/2) guarantees how close the Q/2 output will be locked to the reference input connected to the SYNC input (including temperature and voltage variation). This also tells what the skew from the Q/2 output on one part connected to a given reference input, to the Q/2 output on one or more parts connected to that reference input (assuming equal delay from the reference input to the SYNC input of each part). Therefore the t<sub>PD</sub> spec is equivalent to a part-to-part specification. However, to correctly predict the skew from a given output on one part to any other output on one or more other parts, the distribution of each output in relation to the SYNC input must be known. This distribution for the MC88916 is provided in Table 1.

TABLE 1. Distribution of Each Output versus SYNC

Output	-(ps)	+(ps)
2X_Q	TBD	TBD
Q0	TBD	TBD
Q1	TBD	TBD
Q2	TBD	TBD
Q3	TBD	TBD
Q/2	TBD	TBD

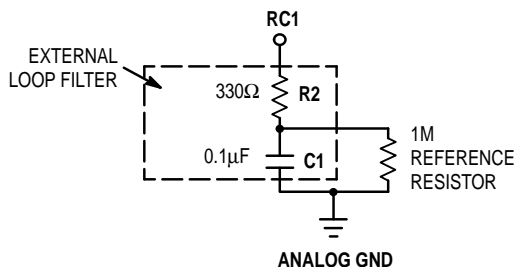

WITH THE 1MΩ RESISTOR TIED IN THIS FASHION THE t<sub>PD</sub> SPECIFICATION, MEASURED AT THE INPUT PINS IS:

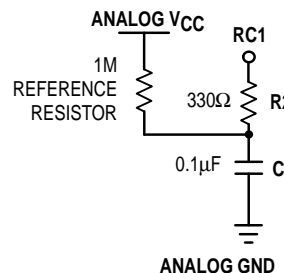
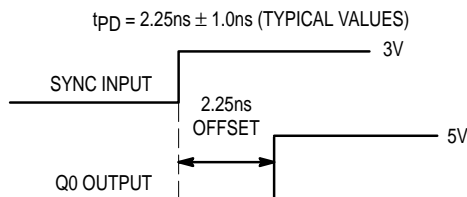

WITH THE 1MΩ RESISTOR TIED IN THIS FASHION THE t<sub>PD</sub> SPECIFICATION, MEASURED AT THE INPUT PINS IS:

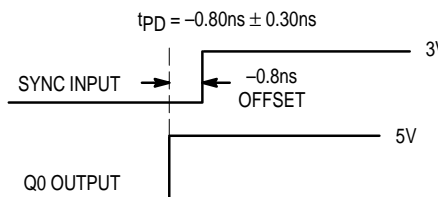

Figure 2. Depiction of the Fixed SYNC to Q0 Offset (t<sub>PD</sub>) Which Is Present When a 1MΩ Resistor Is Tied to V<sub>CC</sub> or Ground

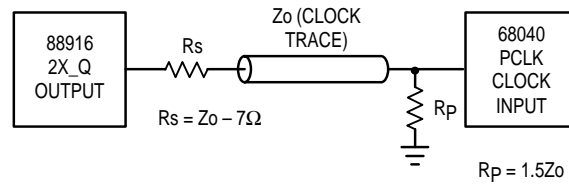

Figure 3. MC68040 PCLK Input Termination Scheme

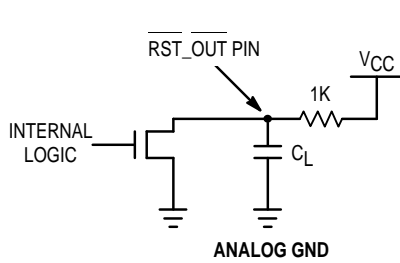

Figure 4. RST\_OUT Test Circuit

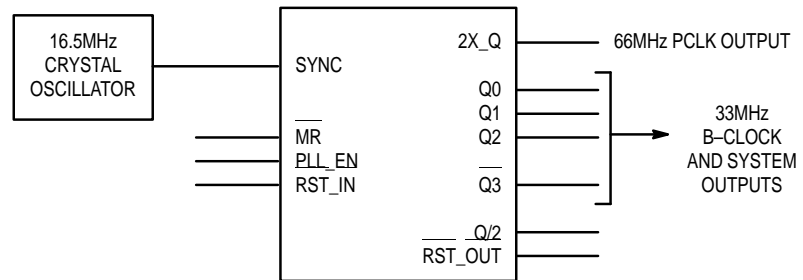

Figure 5. Logical Representation of the MC88916 With Input/Output Frequency Relationships

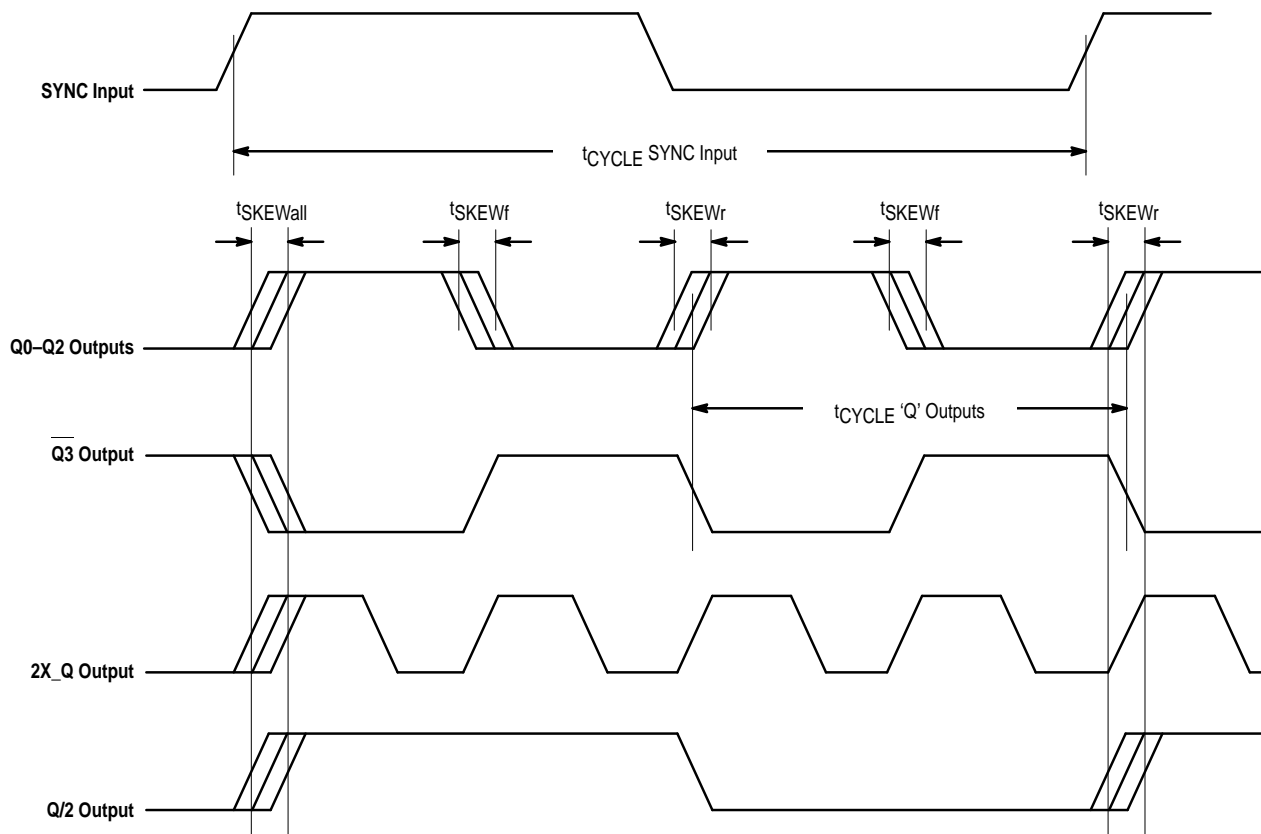

Figure 6. Output/Input Switching Waveforms and Timing Relationships

**Timing Notes**

1. The MC88916 aligns rising edges of the outputs and the SYNC input, therefore the SYNC input does not require a 50% duty cycle.
2. All skew specs are measured between the  $V_{CC}/2$  crossing point of the appropriate output edges. All skews are specified as 'windows', not as a  $\pm$  deviation around a center point.

The  $t_{PD}$  spec includes the full temperature range from 0°C to 70°C and the full  $V_{CC}$  range from 4.75V to 5.25V. If the  $\Delta T$  and  $\Delta V_{CC}$  in a given system are less than the specification limits, the  $t_{PD}$  spec window will be reduced. The  $t_{PD}$  window for a given  $\Delta T$  and  $\Delta V_{CC}$  is given by the following regression formula:

TBD

- The  $\overline{RST\_OUT}$  pin is an open drain N-Channel output. Therefore an external pull-up resistor must be provided to pull up the  $\overline{RST\_OUT}$  pin when it goes into the high impedance state (after the MC88916 is phase-locked to the reference input with  $\overline{RST\_IN}$  held high or 1024 'Q' cycles after the  $\overline{RST\_IN}$  pin goes high when the part is locked). In the  $t_{PLZ}$  and  $t_{PZL}$  specifications, a 1K $\Omega$  resistor is used as a pull-up as shown in Figure 4.

### Notes Concerning Loop Filter and Board Layout Issues

- Figure 7 shows a loop filter and analog isolation scheme which will be effective in most applications. The following guidelines should be followed to ensure stable and jitter-free operation:
  - All loop filter and analog isolation components should be tied as close to the package as possible. Stray current passing through the parasitics of long traces can cause undesirable voltage transients at the RC1 pin.
  - The 47 $\Omega$  resistors, the 10 $\mu$ F low frequency bypass capacitor, and the 0.1 $\mu$ F high frequency bypass capacitor form a wide bandwidth filter that will make the 88916 PLL insensitive to voltage transients from the system digital  $V_{CC}$  supply and ground planes. This filter will typically ensure that a 100mV step deviation on the digital  $V_{CC}$  supply will cause no more than a 100ps phase deviation on the 88916 outputs. A 250mV step deviation on  $V_{CC}$  using the recommended filter values will cause no more than a 250ps phase deviation; if a 25 $\mu$ F bypass capacitor is used (instead of 10 $\mu$ F) a 250mV  $V_{CC}$  step will cause no more than a 100ps phase deviation.

If good bypass techniques are used on a board design near components which may cause digital  $V_{CC}$  and ground noise, the above described  $V_{CC}$  step deviations should not occur at the 88916's digital  $V_{CC}$  supply. The purpose of the bypass filtering scheme shown in Figure 7

is to give the 88916 additional protection from the power supply and ground plane transients that can occur in a high frequency, high speed digital system.

- There are no special requirements set forth for the loop filter resistors (1M and 330 $\Omega$ ). The loop filter capacitor (0.1 $\mu$ F) can be a ceramic chip capacitor, the same as a standard bypass capacitor.
  - The 1M reference resistor injects current into the internal charge pump of the PLL, causing a fixed offset between the outputs and the SYNC input. This also prevents excessive jitter caused by inherent PLL dead-band. If the VCO (2X\_Q output) is running above 40MHz, the 1M resistor provides the correct amount of current injection into the charge pump (2–3 $\mu$ A). If the VCO is running below 40MHz, a 1.5M $\Omega$  reference resistor should be used.
- In addition to the bypass capacitors used in the analog filter of Figure 7, there should be a 0.1 $\mu$ F bypass capacitor between each of the other (digital) four  $V_{CC}$  pins and the board ground plane. This will reduce output switching noise caused by the 88916 outputs, in addition to reducing potential for noise in the 'analog' section of the chip. These bypass capacitors should also be tied as close to the 88916 package as possible.

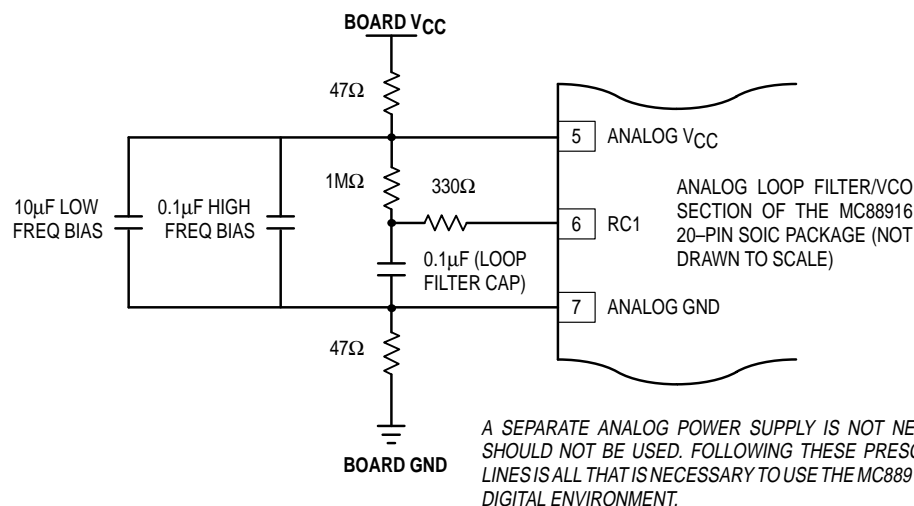
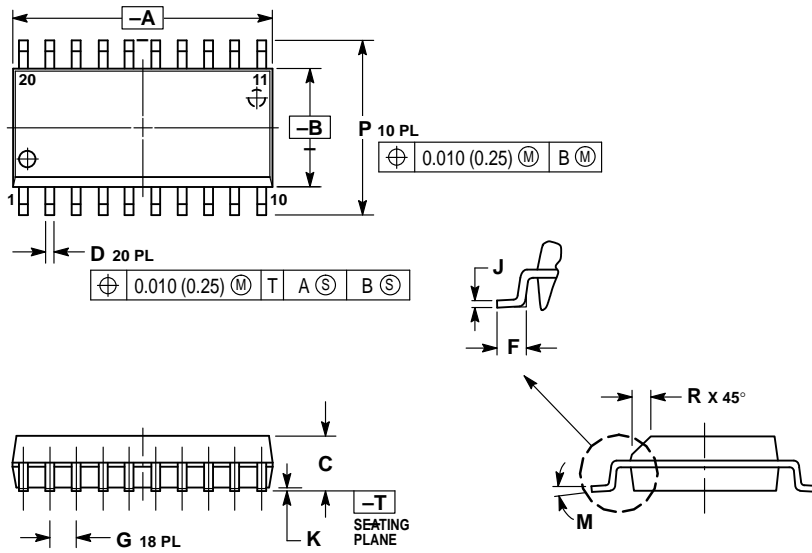

Figure 7. Recommended Loop Filter and Analog Isolation Scheme for the MC88916



OUTLINE DIMENSIONS

DW SUFFIX  
 PLASTIC SOIC PACKAGE  
 CASE 751D-04  
 ISSUE E



- NOTES:
1. DIMENSIONING AND TOLERANCING PER ANSI Y14.5M, 1982.
  2. CONTROLLING DIMENSION: MILLIMETER.
  3. DIMENSIONS A AND B DO NOT INCLUDE MOLD PROTRUSION.
  4. MAXIMUM MOLD PROTRUSION 0.150 (0.006) PER SIDE.
  5. DIMENSION D DOES NOT INCLUDE DAMBAR PROTRUSION. ALLOWABLE DAMBAR PROTRUSION SHALL BE 0.13 (0.005) TOTAL IN EXCESS OF D DIMENSION AT MAXIMUM MATERIAL CONDITION.

DIM	MILLIMETERS		INCHES	
	MIN	MAX	MIN	MAX
A	12.65	12.95	0.499	0.510
B	7.40	7.60	0.292	0.299
C	2.35	2.65	0.093	0.104
D	0.35	0.49	0.014	0.019
F	0.50	0.90	0.020	0.035
G	1.27 BSC		0.050 BSC	
J	0.25	0.32	0.010	0.012
K	0.10	0.25	0.004	0.009
M	0°	7°	0°	7°
P	10.05	10.55	0.395	0.415
R	0.25	0.75	0.010	0.029

Innovate with IDT and accelerate your future networks. Contact:

**www.IDT.com**

**For Sales**

800-345-7015  
408-284-8200  
Fax: 408-284-2775

**For Tech Support**

netcom@idt.com  
480-763-2056

---

**Corporate Headquarters**

Integrated Device Technology, Inc.  
6024 Silver Creek Valley Road  
San Jose, CA 95138  
United States  
800 345 7015  
+408 284 8200 (outside U.S.)

**Asia Pacific and Japan**

Integrated Device Technology  
Singapore (1997) Pte. Ltd.  
Reg. No. 199707558G  
435 Orchard Road  
#20-03 Wisma Atria  
Singapore 238877  
+65 6 887 5505

**Europe**

IDT Europe, Limited  
Prime House  
Barnett Wood Lane  
Leatherhead, Surrey  
United Kingdom KT22 7DE  
+44 1372 363 339